

CIRCULAR CONNECTORS



SIGNAL // POWER // INDUSTRIAL ETHERNET



HUMMEL — smart & reliable



HUMMEL AG is a renowned manufacturer of connection technology and components for electric and heating areas. The medium sized family business stands for quality, precision, reliability and pronounced service consciousness. A wide vertical range of manufacture with in-house development, construction, toolmaking, manufacturing, electroplating and assembling from a single source, offers best conditions for implementing individual solutions.



Connectors M 12 Power

▶ 19



Connectors M 16

▶ 37



Connectors M 23 Fast Ethernet PoE

▶ 63



Connectors M 23 RJ 45

▶ 75



Connectors M 23 Signal

▶ 85



Connectors M 27 Signal

▶ 117



Connectors M 23 Power, M 23 Hybrid

▶ 127

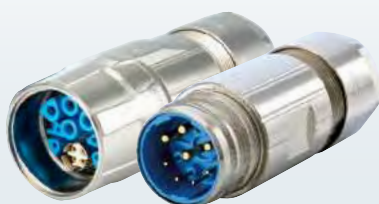

Connectors M 40 Power (Size 1,5)

▶ 153



Connectors Stainless Steel (INOX) ▶ 171

▶ 171



Moulded Cordsets ▶ 181

▶ 181



Customized – No Limits ▶ 188

▶ 188



HUMMEL Highlights: product features ▶ 6

▶ 6

Technical Information ▶ 18

▶ 18

Index ▶ 196

▶ 196

HUMMEL International ▶ 198

▶ 198

LEGEND



Contacts



Accessories



Assembly Instructions



Crimping, Assembly and Disassembly of Contacts



Housing



Crimp Tool Settings



Inserts/Pinouts



Crimp Tool Assembly Instruction



HUGE RANGE: M 8 – M 40

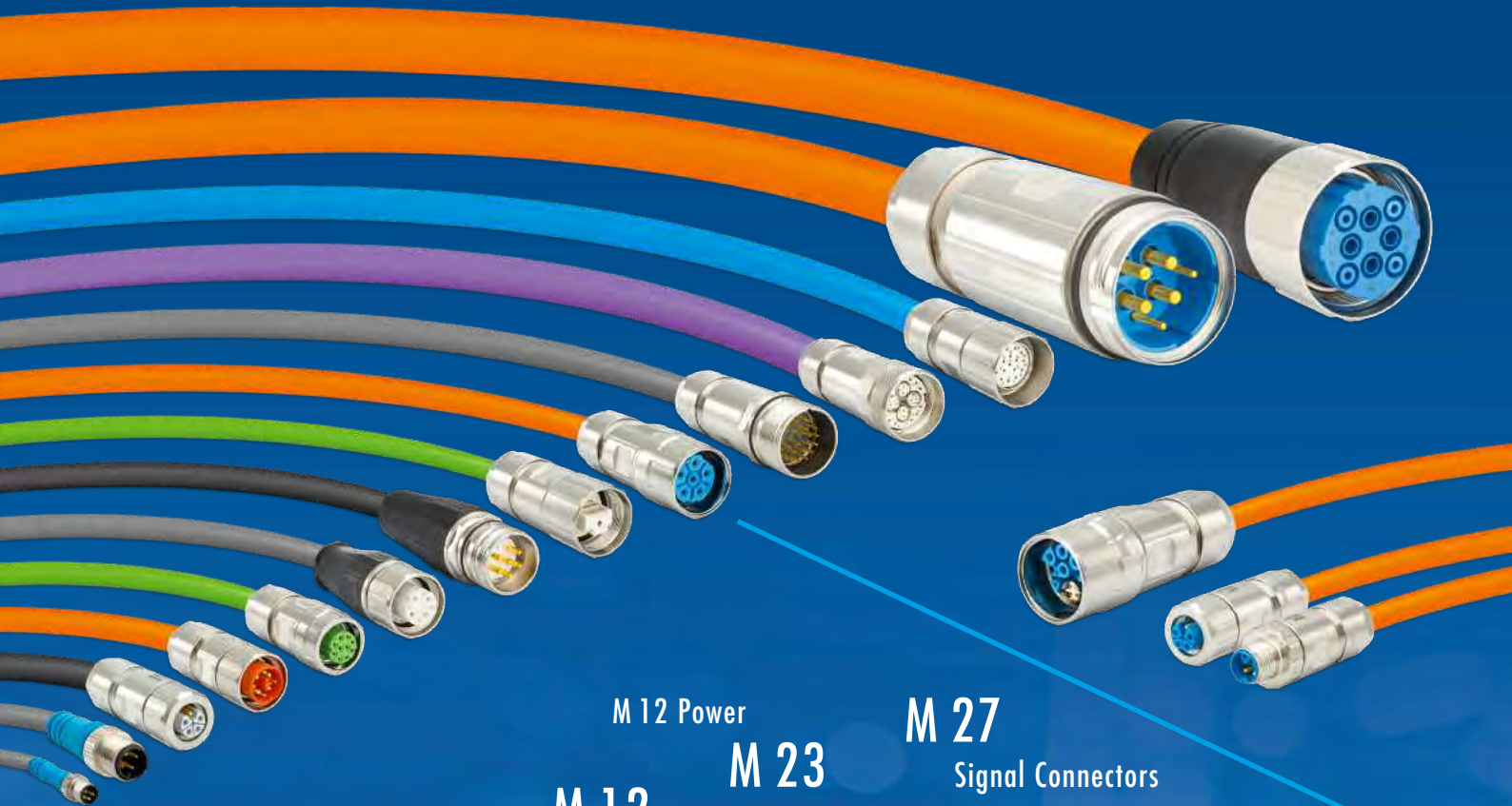

M 12 Power
M 12
 M 23
 Power Connectors
 M 27
 Signal Connectors

CIRCULAR CONNECTORS

M 8 Industrial Ethernet
 M 16 TWILOCK
 PROFINET
 M 23 RJ 45
 M 40 Moulded Cordsets
 Customized Solutions
 M 23 Hybrid



Germanischer Lloyd



File-No. E 213337

TWILOCK / TWILOCK-S

- // Quick Connect with Polygon Lock
- // Multi functional: Ideal with TWILOCK and screw connection
- // Easy handling, exceptional functionality
- // Resistant to vibration



Clearly defined:
OPEN – CLOSE

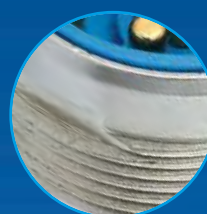

Multi functional: Special thread
allows use of TWILOCK and
screw connection



Locking with a slight rotation
or release of the connection



TWILOCK-S-Version
intermateable with Speedtec



M 12 Power – compact and powerful

It is a major milestone in an age of miniaturization: the presentation of the M 12 Power Connector. This circular connector opens the door to entirely new applications and capabilities. Its high power transmission, the compact design and the large temperature range are the extraordinary features. The mechanical and electrical data of this compact power connector are convincing.

- // Power transmission to 630V and 16 A
- // Temperature range to 125 degree Celsius
- // K, L, S, T Coding
- // EMC shielding in standard version
- // Robust metal housing, optional stainless steel
- // Protection IP 67 and IP 69K
- // Compact designs
- // Cable diameter range to 11 mm
- // Moulded Cordsets

Coding:

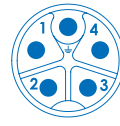

K

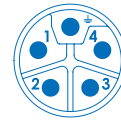

L

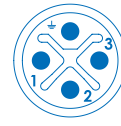

S



T



Euro-Lock-System – the patented locking system

- // The integrated locking clip secures the contacts in the insert
- // Easy assembly and disassembly of the contacts
- // No special tools required

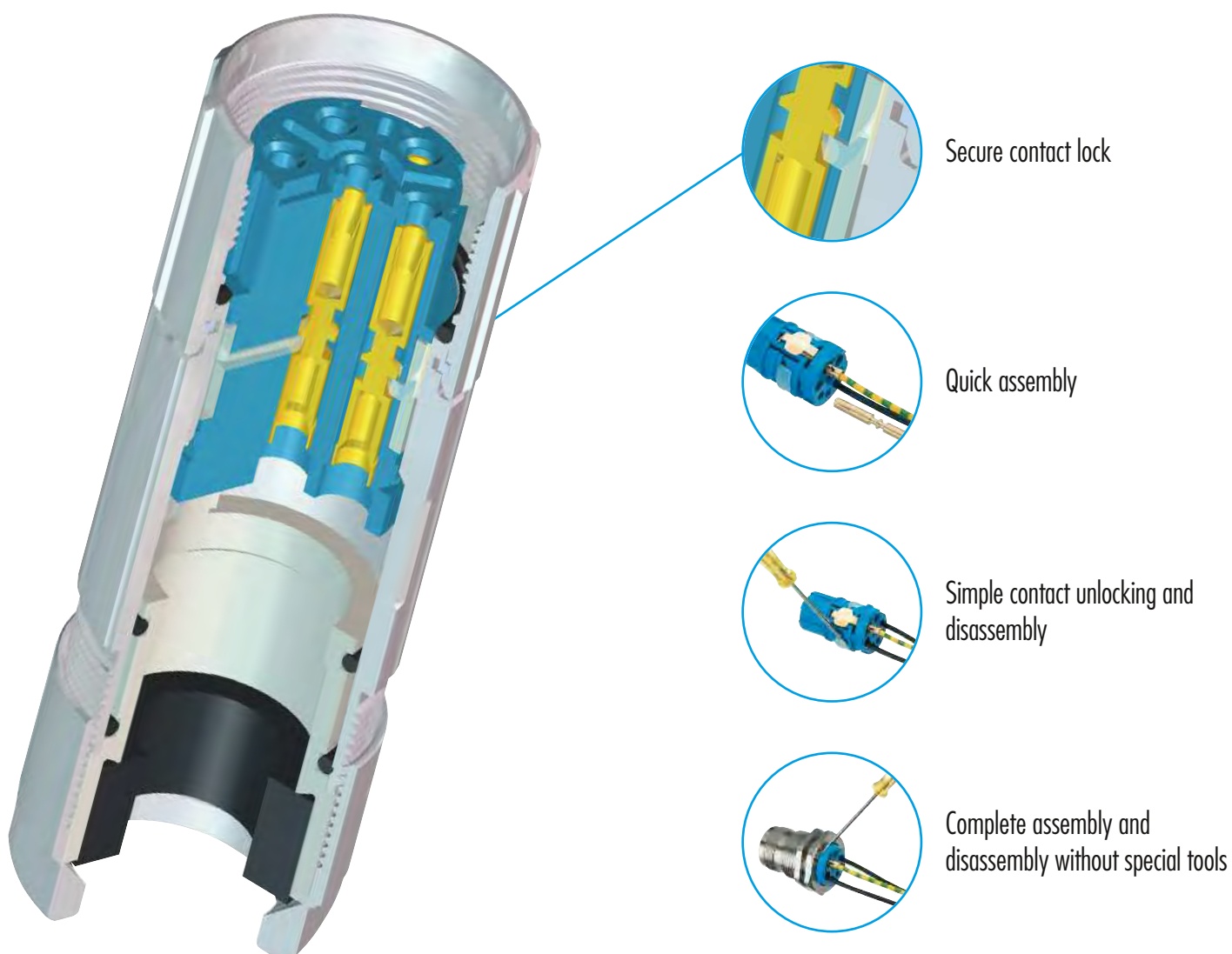

The new Low-Cost-Standard for Drives

- // Minimized Size
- // Free choice of Signal and Power Inserts
- // Flange 20 x 20 and 25 x 25

Connector 4 small drives

TWINTUS



Colour coded inserts
(DESINA colour code)



IP 67 (NEMA 4x) self sealing,
even for threaded holes



Optional EMC-sheet for separating
signal and power areas



Version M 16 / M 12 available

Fully integrated solution for Industrial Ethernet applications

- // Fits perfect for single cable and hybrid solutions for HIPERFACE® DSL and EnDat 2.2 use
- // High Performance
- // Full modularity with Nickel Plated Brass and Stainless Steel Shells
- // TWILOCK quick connect system

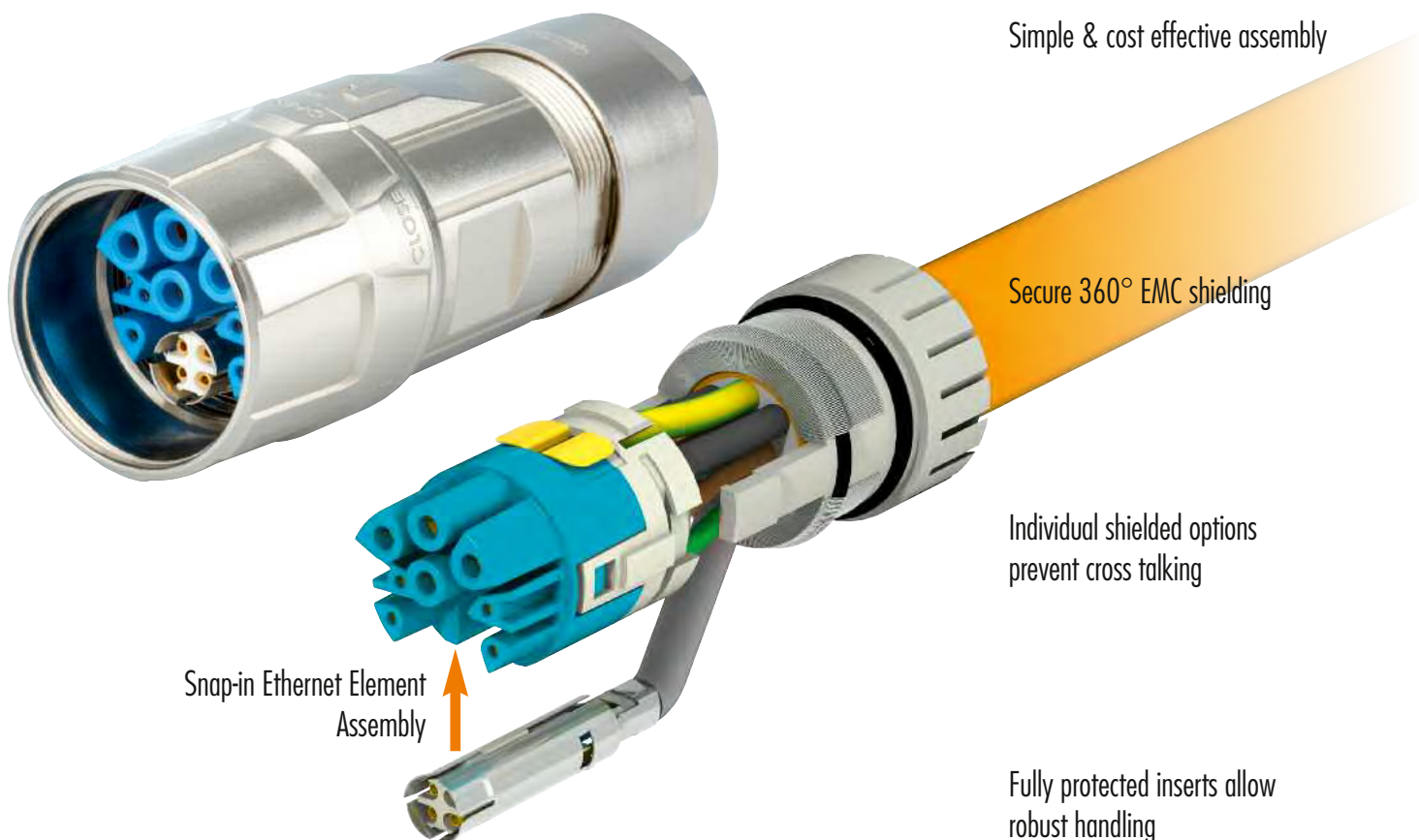



M 23 RJ 45: ROBUST, SIMPLE & SMALL!



Design allows for terminated patch cable



Integrated coupler accommodates off-the-shelf RJ 45 patch cables



Integrated cable strain relief warrant an IP 67 / IP 69K rating making the M 23 based RJ 45 Connector an ideal solution for robust applications



A standard RJ 45 connection is suitable as service and programmable interface

The new, high performance type of contacts – HUMMEL SLS-Technology (Spring Loaded Socket)

- // Integrated spring mates with the pin contact and encompasses it radially
- // Exceptional electrical performance with ultimate contact reliability
- // Tinned solder contacts assure easy and quick assembly

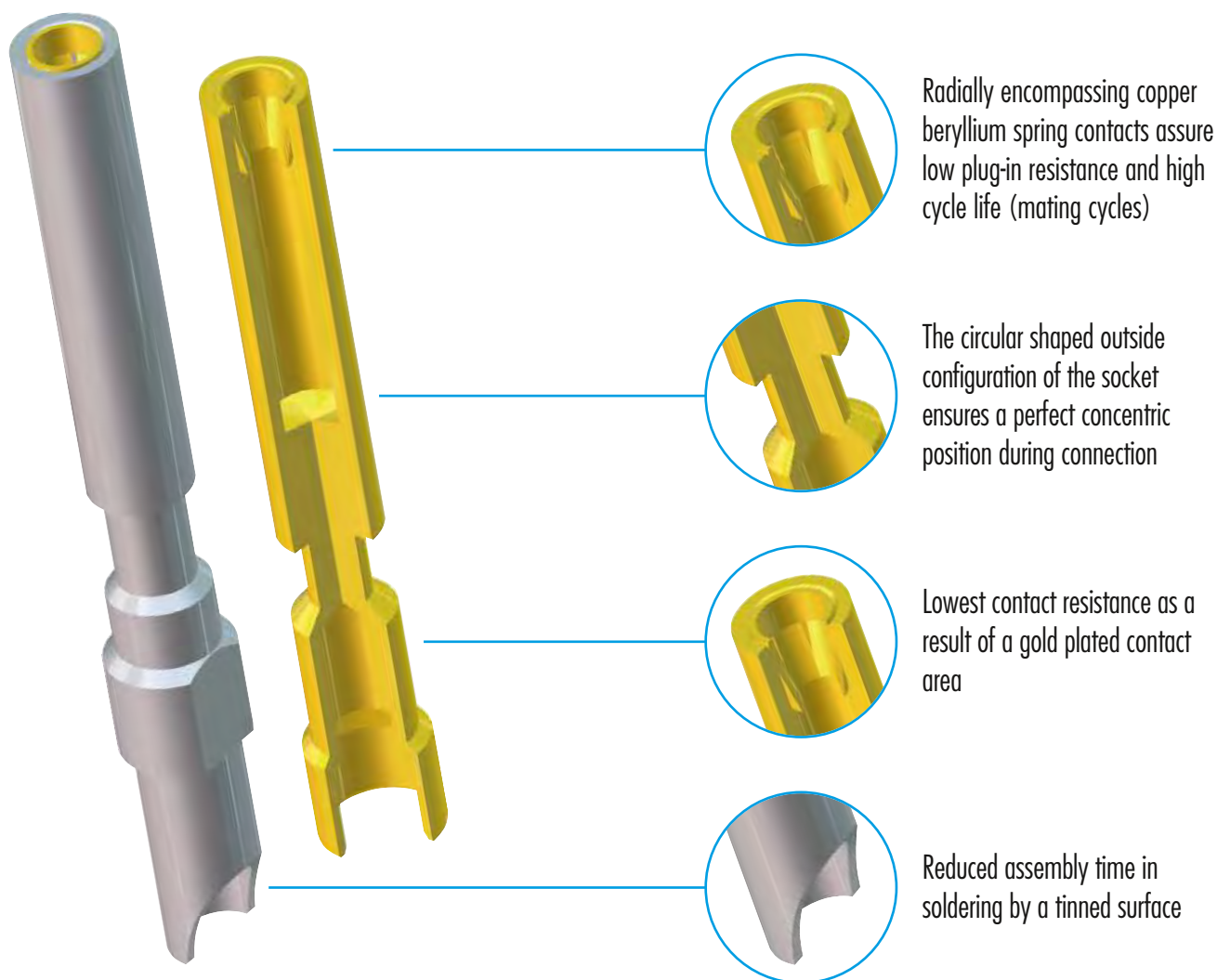

USER FRIENDLY ASSEMBLY

- // Clear and modular structure of all connector series
- // Patented modular strain relief insert and contact insert
- // One step cable assembly and shielding
- // Simple, quick and reliable assembly into the connector housing

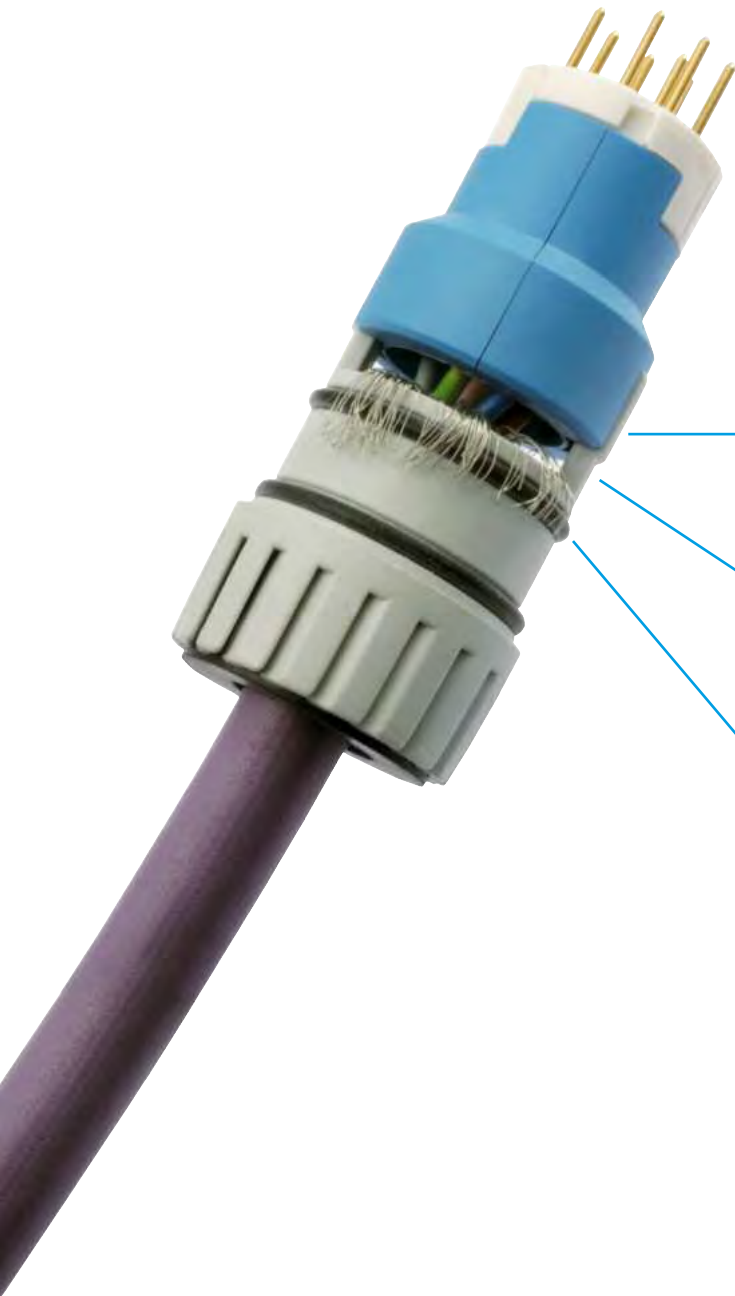

Colour coding of spacers for male and female inserts



Cable assembly and shielding is possible in a single operation



Strain relief insert with four fingers, secured in a recess, prevents cable rotation



Flexible EMC-O-ring guarantees reliable EMC-protection for light and heavy braided shields.

A giant modular construction set

The modular design is what makes it possible: Many types of HUMMEL connector housing can be combined with numerous other contact inserts. For clients, this means that every conceivable number of contacts can be created using just one type of connector as a basis. The system works like a giant modular construction set. There are many benefits:

- // huge amount of combinations
- // consistent assembly
- // easy procurement
- // minimized storage
- // assembly with standard tools



Straight Connector, Male- & Female Thread



Panel Connector

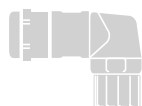

Right Angle Connector



Versions TWILOCK / TWILOCK-S

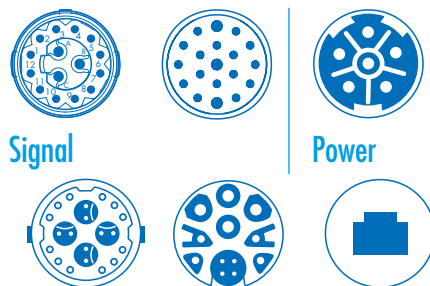

Signal

Power

Industrial Ethernet

This is how the system works:

- // decide on one of the connector series based on the intended application and the desired number of positions (M 12 Power, M 16, M 23 Fast Ethernet PoE, M 23 RJ 45, M 23 Signal, M 27 Signal, M 23 Power / Hybrid, M 40 Power)
- // choose a housing (straight connector male or female thread, right-angle or panel connector) with the requested connect system (screw, TWILOCK, TWILOCK-S)
- // select a suitable insert
- // choose the corresponding contacts (pin or socket) in the requested number

M 23 CIRCULAR CONNECTORS

The success serie

Robust and easy to mount: These are the highlights of the successful M23 serie. With HUMMEL connectors the housings, the inserts and the contacts can be combined. Therefore the system is extremely flexible and suitable for nearly every application. The mechanical and electrical data are also outstanding and prove absolute industrial suitability

- // Applications: signal, power, industrial ethernet (Hybrid, RJ45, Profinet)
- // screw connection, quick connection TWILOCK and TWILOCK-S (intermateable with Speedtec)
- // compact design for assembling in small spaces
- // Protection IP 67 and IP 69 K (connected)
- // Temperature range -40° C to + 125° C
- // certified for UL, CSA and VDE



- // Insert can be used for all types of contacts
- // Crimp contacts machined or on tape
- // Solder contacts for manual soldering or dip soldered for PC boards

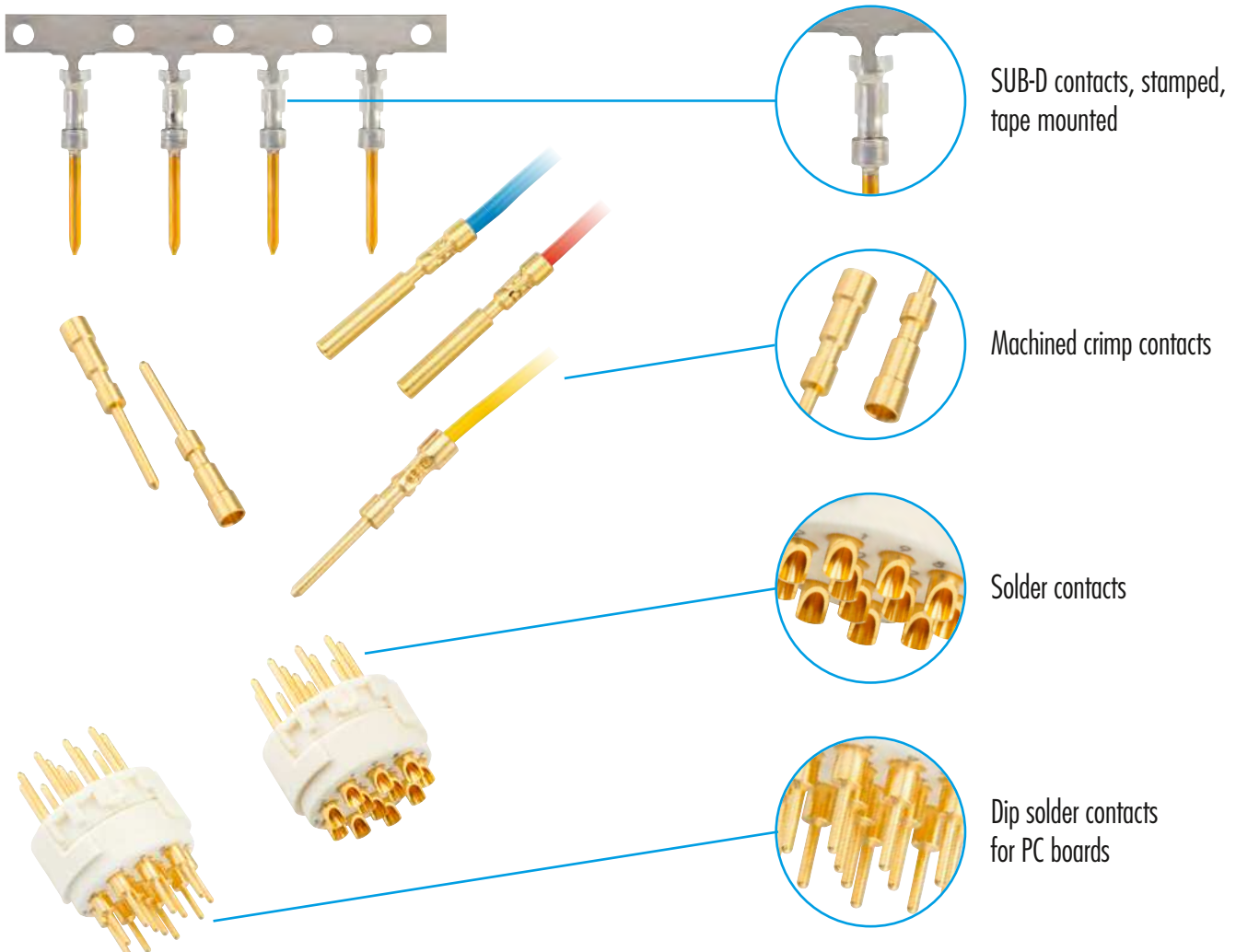

Nominal Current

Allowable current (Amp), that can be transmitted by each contact continuously and simultaneously.

Nominal Voltage

Allowable voltage (Volt), that can be applied to each contact continuously and simultaneously.

Test Voltage

Voltage which, under certain conditions, a connector can be exposed to without breakdown.

Degree of Protection

Potential dirt accumulation of a disconnected connector in a certain environment.

Degree of Protection 2

No permanent conductive dirt accumulation will occur. Temporary conductive dirt accumulation, such as condensation, is possible. Typical for households, offices, laboratories and test labs.

Degree of Protection 3

Conductive, as well as dry non-conductive dirt accumulation can occur. It can be temporarily conductive due to condensation. Typical for industrial and factory environments.

Additional remarks (pollution level)

If connectors being defined for pollution degree 1 and overvoltage category 1 are applied for other conditions (higher pollution degree and higher overvoltage category) voltages level reduce correspondingly. But the connectors can be used without any problems at reduced maximum voltages.

Mating cycles

Mating cycles are the number of insertion and extraction cycles a connector can withstand before the electrical or mechanical failure in relationship to the connector's design specification.

Air gap

The minimum gap of air between two conducting surfaces permissible at given voltage.

Creep distance

The minimum dimension along the surface of an insulating material between two conducting surfaces.

PE

The PE-Contact is a ground contact for security reasons.

Safety Guidelines

When HUMMEL connectors are used for voltages greater than 50 Volts with conductive shell components they must be used in accordance with the safety regulations DIN VDE Part 410; IEC 60364-4-41. This regulation basically dictates that the power source should be turned off before mating and unmating connector. This regulation does not provide protection against electrical shock when mating and unmating connectors in the field.



Don't connect or disconnect HUMMEL Connectors under load.

The dimensions for processing refer to harmonized cables. In practice, these dimensions may differ for individual cables.

CONNECTORS M 12 POWER

The M 12 Power connector impresses with its compact design and high power transmission. This connector enables entirely new applications and capabilities. It is available in numerous versions.

- // Straight Connector, male and female thread
- // Right Angle Connector, male and female thread
- // Panel Connectors
- // Moulded Cordsets
- // Field Attachable connectors
- // Accessories
- // Cable Assembly

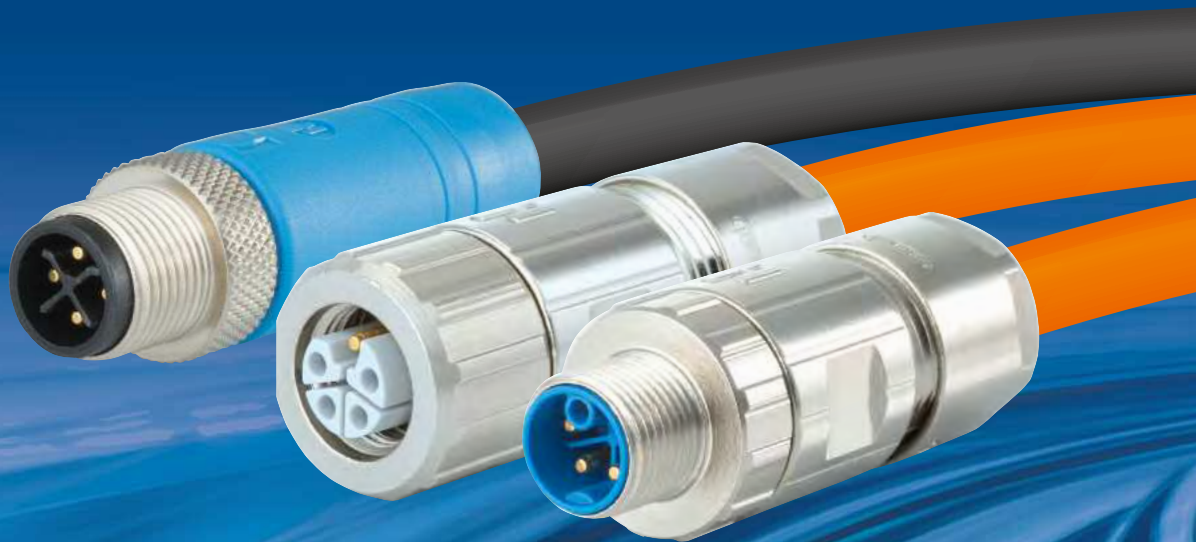

Product overview

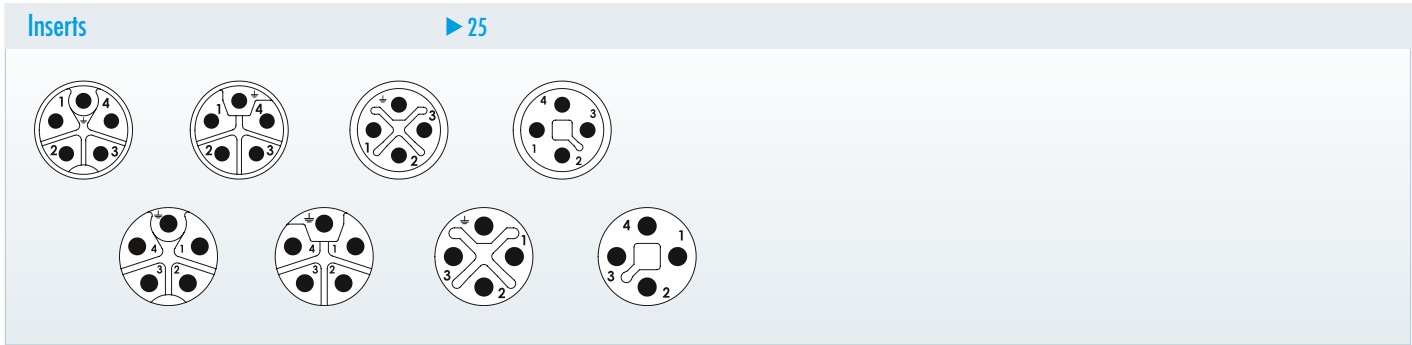

Mechanical Data	Materials and Technical Data
Housing	Brass / Die Cast INOX AISI 316 L TPU (moulded versions)
Housing surface	Nickel plated Other surfaces upon request
Inserts (for contacts)	PBT Fire protection class V-0
Contacts	Copper alloy / Brass
Contact Area	Gold plated
Minimum mating cycles	> 100
Sealings / O-rings	Viton® (FKM / FPM) / Buna-N / HNBR
Temperature range	-40°C – 125°C (-40°F – 257°F) (K + L) -40°C – 85°C (-40°F – 185°F) (S + T)
Type of contacts	Crimp (K + L) / Screw Terminal (S + T)
Protection Class	IP 67 / IP 69K
Cable diameter range	3 – 11 mm (.11 – .43")

Electrical Data	S	T	K	L
Coding	S	T	K	L
Colours	black	dark grey	blue	grey
Number of positions	4 (3 + PE)	4	5 (4 + PE)	5 (4 + FE)
Terminal Cross Section [mm ²]	0,5 – 1,5	0,5 – 1,5	0,75 – 2,5	0,75 – 2,5
AWG	AWG 20 – 16	AWG 20 – 16	AWG 18 – 14	AWG 18 – 14
Nominal current ¹ [A]	12	12	16	16
Nominal voltage ² [V~] degree of protection ^{3 4}	630	63	630	63
Test voltage (Breakdown voltage) ³ [V~]	3310	840	3310	840
Insulation resistance [MΩ]	>10 ²	>10 ²	>10 ²	>10 ²
Max. contact resistance [mΩ]	<3	<3	<3	<3

^{1), 2), 3), 4)} See Technical Information page 18



Housings

⚠ Pin inserts mountable with male thread housings only. Socket inserts mountable with female thread housings only.

Straight Connector, Female Thread

Cable-Ø	Coding	Part Number
3 – 6 mm (.11 – .23")K, L.....	A712-7.K10.300.000
5 – 9 mm (.20 – .35")K, L.....	A712-7.K10.400.000
8 – 11 mm (.31 – .43")K, L.....	A712-7.K10.500.000
3 – 6 mm (.11 – .23")S, T.....	A712-7.S10.300.000
5 – 9 mm (.20 – .35")S, T.....	A712-7.S10.400.000
8 – 11 mm (.31 – .43")S, T.....	A712-7.S10.500.000

▶ 25 | ▶ 30 | ▶ 31/32

Straight Connector, Male Thread

Cable-Ø	Coding	Part Number
3 – 6 mm (.11 – .23")K, L.....	A712-7.K20.300.000
5 – 9 mm (.20 – .35")K, L.....	A712-7.K20.400.000
8 – 11 mm (.31 – .43")K, L.....	A712-7.K20.500.000
3 – 6 mm (.11 – .23")S, T.....	A712-7.S20.300.000
5 – 9 mm (.20 – .35")S, T.....	A712-7.S20.400.000
8 – 11 mm (.31 – .43")S, T.....	A712-7.S20.500.000

▶ 25 | ▶ 30 | ▶ 31/32

Right Angle Connector, Female Thread

Cable-Ø	Coding	Part Number
3 – 6 mm (.11 – .23")K, L.....	A712-7.K30.300.000
5 – 9 mm (.20 – .35")K, L.....	A712-7.K30.400.000
8 – 11 mm (.31 – .43")K, L.....	A712-7.K30.500.000
3 – 6 mm (.11 – .23")S, T.....	A712-7.S30.300.000
5 – 9 mm (.20 – .35")S, T.....	A712-7.S30.400.000
8 – 11 mm (.31 – .43")S, T.....	A712-7.S30.500.000

▶ 25 | ▶ 30 | ▶ 33/34

Right Angle Connector, Male Thread

Cable-Ø	Coding	Part Number
3 – 6 mm (.11 – .23")K, L.....	A712-7.K31.300.000
5 – 9 mm (.20 – .35")K, L.....	A712-7.K31.400.000
8 – 11 mm (.31 – .43")K, L.....	A712-7.K31.500.000
3 – 6 mm (.11 – .23")S, T.....	A712-7.S31.300.000
5 – 9 mm (.20 – .35")S, T.....	A712-7.S31.400.000
8 – 11 mm (.31 – .43")S, T.....	A712-7.S31.500.000

▶ 25 | ▶ 30 | ▶ 33/34

Housing without inserts and contacts

Pin inserts mountable with male thread housings only. Socket inserts mountable with female thread housings only.

Panel connector male thread, single hole front mounted

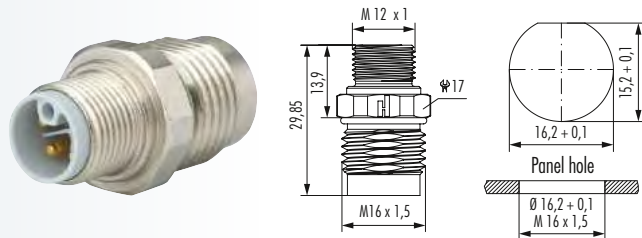

Type Part Number

Thread M 16 K, L.....A712-7.K42.000.000
 Thread M 20 K, L.....A712-7.K42.100.000
 Thread M 20 S, T.....A712-7.S42.000.000

with lock nut „rotation protection“

Thread M 16 K, L.....A712-7.K42.000.00G
 Thread M 20 K, L.....A712-7.K42.100.00G
 Thread M 20 S, T.....A712-7.S42.000.00G



Panel connector female thread, single hole front mounted

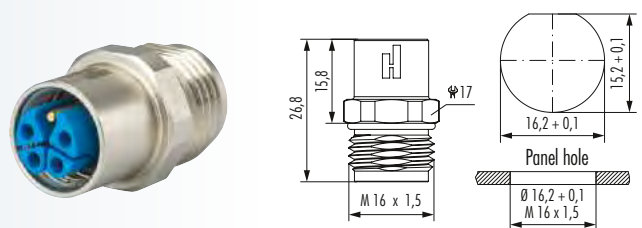

Type Part Number

Thread M 16 K, L.....A712-7.K44.000.000
 Thread M 20 K, L.....A712-7.K44.100.000
 Thread M 20 S, T.....A712-7.S44.000.000

with lock nut „rotation protection“

Thread M 16 K, L.....A712-7.K44.000.00G
 Thread M 20 K, L.....A712-7.K44.100.00G
 Thread M 20 S, T.....A712-7.S44.000.00G



Panel connector male thread, single hole rear mounted

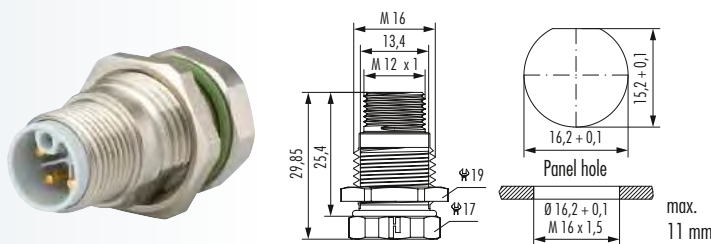

Type Part Number

Thread M 16 K, L.....A712-7.K50.000.000
 Thread M 20 S, T.....A712-7.S50.000.000



Panel connector female thread, single hole rear mounted

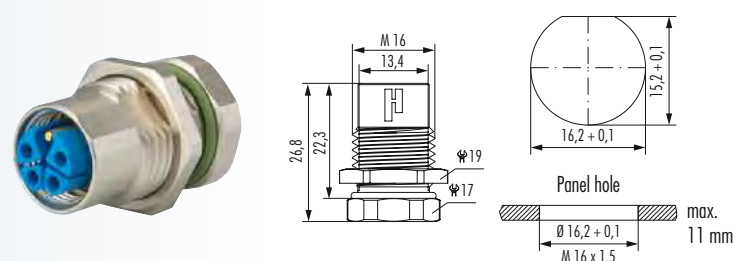

Type Part Number

Thread M 16 K, L.....A712-7.K51.000.000
 Thread M 20 S, T.....A712-7.S51.000.000



Housing without inserts and contacts

Drawings apply for coding K and L only. Find measures for coding S and T at www.hummel.com



Pin inserts mountable with male thread housings only. Socket inserts mountable with female thread housings only.

Inserts K-coding		Type	Part Number
		Crimp insert, pins, 4 + PE without contacts.....	A712-7.K03.941.101
Insert pin mating view	Insert socket mating view	Required contacts: 4 x pins, 1 x socket PE	
		Crimp insert, sockets, 4 + PE without contacts.....	A712-7.K03.941.102
		Required contacts: 4 x sockets, 1 x pin	
		max. wire insulation Ø 2,9 mm	
		▶ 26	

Inserts L-coding		Type	Part Number
		Crimp insert, pins, 4 + FE without contacts.....	A712-7.L03.941.101
Insert pin mating view	Insert socket mating view	Required contacts: 4 x pins, 1 x socket PE	
		Crimp insert, sockets, 4 + FE without contacts.....	A712-7.L03.941.102
		Required contacts: 4 x sockets, 1 x pin	
		max. wire insulation Ø 2,9 mm	
		▶ 26	

Inserts S-coding		Type	Part Number
		Insert with pins 3 + PE contacts with screw termination.....	A712-7.S05.931.105
Insert pin mating view	Insert socket mating view	Insert with sockets 3 + PE contacts with screw termination.....	A712-7.S05.931.106

Inserts T-coding		Type	Part Number
		Insert with pins 4-pole contacts with screw termination.....	A712-7.T05.904.105
Insert pin mating view	Insert socket mating view	Insert with sockets 4-pole contacts with screw termination.....	A712-7.T05.904.106

Contacts / Crimp Tool Setting for HUMMEL Crimp Contacts (Crimp Tool 7.000.900.908)

Contacts	Type	Crimp Range	Part Number
	Crimp pin 1,5 mm, machined	0,75 mm ²	A712-7.010.901.521 ¹
	Crimp pin 1,5 mm, machined	1,5 mm ²	A712-7.010.901.531
	Crimp pin 1,5 mm, machined	2,5 mm ²	A712-7.010.901.541
	Crimp socket 1,5 mm PE, machined	0,75 mm ²	A712-7.010.911.522 ¹
	Crimp socket 1,5 mm PE, machined	1,5 mm ²	A712-7.010.911.532
	Crimp socket 1,5 mm PE, machined	2,5 mm ²	A712-7.010.911.542
	Crimp socket 1,5 mm, machined	0,75 mm ²	A712-7.010.901.522 ¹
	Crimp socket 1,5 mm, machined	1,5 mm ²	A712-7.010.901.532
	Crimp socket 1,5 mm, machined	2,5 mm ²	A712-7.010.901.542

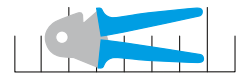

Part Number	Crimp Contact	Cross Section (mm ²)	AWG	Crimp Tool Setting mm	Locator Setting
A712-7.010.901.531	Crimp pin 1,5 mm	1,5	16	1,45	P1
A712-7.010.901.541	Crimp pin 1,5 mm	2,5	14	1,70	P1
A712-7.010.911.532	Crimp socket 1,5 mm PE	1,5	16	1,45	P2
A712-7.010.911.542	Crimp socket 1,5 mm PE	2,5	14	1,70	P2
A712-7.010.901.532	Crimp socket 1,5 mm	1,5	16	1,45	P3
A712-7.010.901.542	Crimp socket 1,5 mm	2,5	14	1,70	P3

These values are only guidelines and actual conductor cross sections depend on manufacturer tolerances.

¹ upon request



M 12 Power Moulded Cordsets, Open cable end

Straight Connector / Open cable end ¹



		M 12 Coding K	M 12 Coding L	M 12 Coding S	M 12 Coding T
Cable (1,5 mm²) PUR					
unshielded	female	A712-KFS413UPxxx	A712-LFS413UPxxx	A712-SFS313UPxxx	A712-TFS043UPxxx
	male	A712-KMS413UPxxx	A712-LMS413UPxxx	A712-SMS313UPxxx	A712-TMS043UPxxx
shielded	female	A712-KFS413SPxxx	A712-LFS413SPxxx	A712-SFS313SPxxx	A712-TFS043SPxxx
	male	A712-KMS413SPxxx	A712-LMS413SPxxx	A712-SMS313SPxxx	A712-TMS043SPxxx
Cable (2,5 mm²) PUR					
unshielded	female	A712-KFS414UPxxx	A712-LFS414UPxxx		
	male	A712-KMS414UPxxx	A712-LMS414UPxxx		
shielded	female	A712-KFS414SPxxx	A712-LFS414SPxxx		
	male	A712-KMS414SPxxx	A712-LMS414SPxxx		

Right Angle Connector / Open cable end ¹



		M 12 Coding K	M 12 Coding L	M 12 Coding S	M 12 Coding T
Cable (1,5 mm²) PUR					
unshielded	female	A712-KFA413UPxxx	A712-LFA413UPxxx	A712-SFA313UPxxx	A712-TFA043UPxxx
	male	A712-KMA413UPxxx	A712-LMA413UPxxx	A712-SMA313UPxxx	A712-TMA043UPxxx

Please add required cable length to part number:

1,5 m	xxx replaced by: 015
2 m	xxx replaced by: 020
5 m	xxx replaced by: 050
10 m	xxx replaced by: 100
15 m	xxx replaced by: 150

The length can be chosen in decimetre (0,1 m) steps.

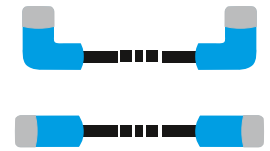

M 12 Power Moulded Cordsets, Extension Cord

Extension cord: Straight Connector / Straight Connector ¹

		M 12 Coding K	M 12 Coding L	M 12 Coding S	M 12 Coding T
Cable (1,5 mm²) PUR					
unshielded	female / male	A712-KFSMS413UPxxx	A712-LFSMS413UPxxx	A712-SFSMS313UPxxx	A712-TFSMS043UPxxx
shielded	female / male	A712-KFSMS413SPxxx	A712-LFSMS413SPxxx	A712-SFSMS313SPxxx	A712-TFSMS043SPxxx
Cable (2,5 mm²) PUR					
unshielded	female / male	A712-KFSMS414UPxxx	A712-LFSMS414UPxxx		
shielded	female / male	A712-KFSMS414SPxxx	A712-LFSMS414SPxxx		

Extension cord: Right Angle Connector / Right Angle Connector ¹

		M 12 Coding K	M 12 Coding L	M 12 Coding S	M 12 Coding T
Cable (1,5 mm²) PUR					
unshielded	female / male	A712-KFAMA413UPxxx	A712-LFAMA413UPxxx	A712-SFAMA313UPxxx	A712-TFAMA043UPxxx

Please add required cable length to part number:

1,5 m	xxx replaced by: 015
2 m	xxx replaced by: 020
5 m	xxx replaced by: 050
10 m	xxx replaced by: 100
15 m	xxx replaced by: 150

The length can be chosen in decimetre (0,1 m) steps.

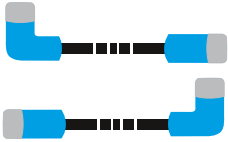

Extension cord: Straight Connector / Right Angle Connector ¹

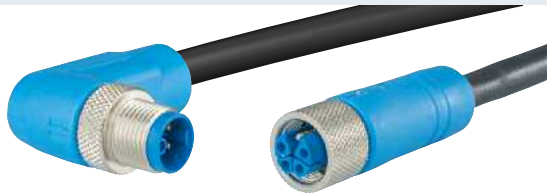

M 12
Coding K



M 12
Coding L

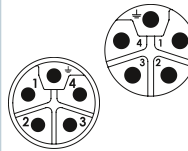

M 12
Coding S

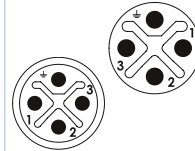

M 12
Coding T

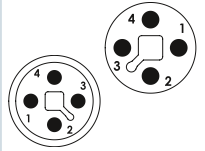

Female Straight Connector / Male Right Angle Connector, Cable (1,5 mm²) PUR

unshielded	female / male	A712-KFSMA413UPxxx	A712-LFSMA413UPxxx	A712-SFSMA313UPxxx	A712-TFSMA043UPxxx
------------	---------------	--------------------	--------------------	--------------------	--------------------

Female Right Angle Connector / Male Straight Connector, Cable (1,5 mm²) PUR

unshielded	female / male	A712-KFAMS413UPxxx	A712-LFAMS413UPxxx	A712-SFAMS313UPxxx	A712-TFAMS043UPxxx
------------	---------------	--------------------	--------------------	--------------------	--------------------

Right Angle Connector, female thread

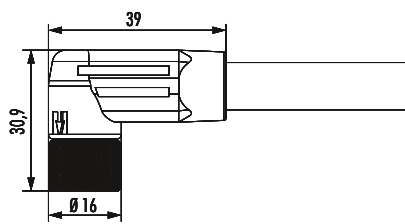

Right Angle Connector, male thread

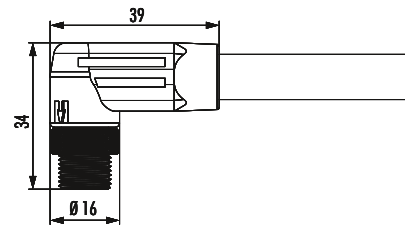

Straight Connector, female thread

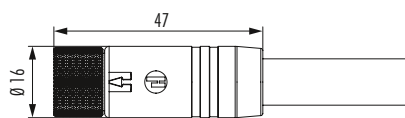



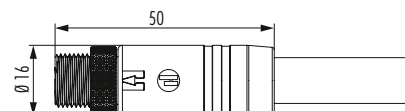







Straight Connector, male thread





Accessories

Accessories	Type	Part Number
	Plastic protective cap for connectors with male thread with female thread	A712-7.000.980.161 A712-7.000.980.162
	Brass protective cap for connectors with female thread	A712-7.010.900.163
	Brass protective cap for connectors with male thread	A712-7.010.900.162
	Brass protective cap with chain for connectors with female thread Length 70 mm	A712-7.010.950.705 ¹
	Brass protective cap with chain for connectors with male thread Length 70 mm	A712-7.010.950.704 ¹
	Crimp tool for manual crimping of machined crimp contacts for signal connectors M 12	7.000.900.908
	 ▶ 26  ▶ 108	
	Tool Adapter for tightening or loosening knurled nuts for M 12 Power/M 16	7.010.900.191
	Screw Tool , adjustable 0.5 – 1.7 Nm	7.010.900.190

¹ upon request

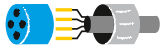

Straight Connector Female / Male Thread, K- / L-Coding

1. max. 25 mm
2. 5 mm
- 3.
4. crimp
5. click
6. code
- 7.
8. 18 18

max. wire insulation Ø 2,9 mm

click

click

click

code

Shield is not allowed to touch second O-ring

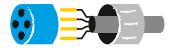

Assembly Instructions

Straight Connector Female/Male Thread, S-/T-Coding

1. 25 mm
2. 10 mm
3. Ferrules are not included
crimp
4. 5 mm
5. 0,2 Nm
6. code
7. 18
8. 18

Shield is not allowed to touch second O-ring

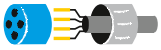

Right Angle Connector Female / Male Thread, K- / L-Coding

1. Strip 30 mm of outer jacket.

2. Strip 5 mm of insulation from conductors.

3. Insert conductors into the connector.

4. Crimp conductors.

5. Push back the crimp sleeve.

6. Push back the outer jacket.

7. Trim the jacket.

8. Tighten the connector with a 17 mm and 18 mm wrench.

Shield is not allowed to touch second O-ring

max. wire insulation Ø 2,9 mm

click

click

Orientation in 45° increments

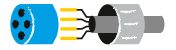

Assembly Instructions

Right Angle Connector Female / Male Thread, S-/T-Coding

- 35 mm
-
-
- ⚠ Ferrules are not included**

crimp

10 mm
-
- click

code
- pull

push

Orientation in 45° increments
-
- 22

18

⚠ Shield is not allowed to touch second O-ring

5 mm (twice)

0,2 Nm

45°

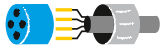

Panel Connector Female / Male Thread, K- / L-Coding

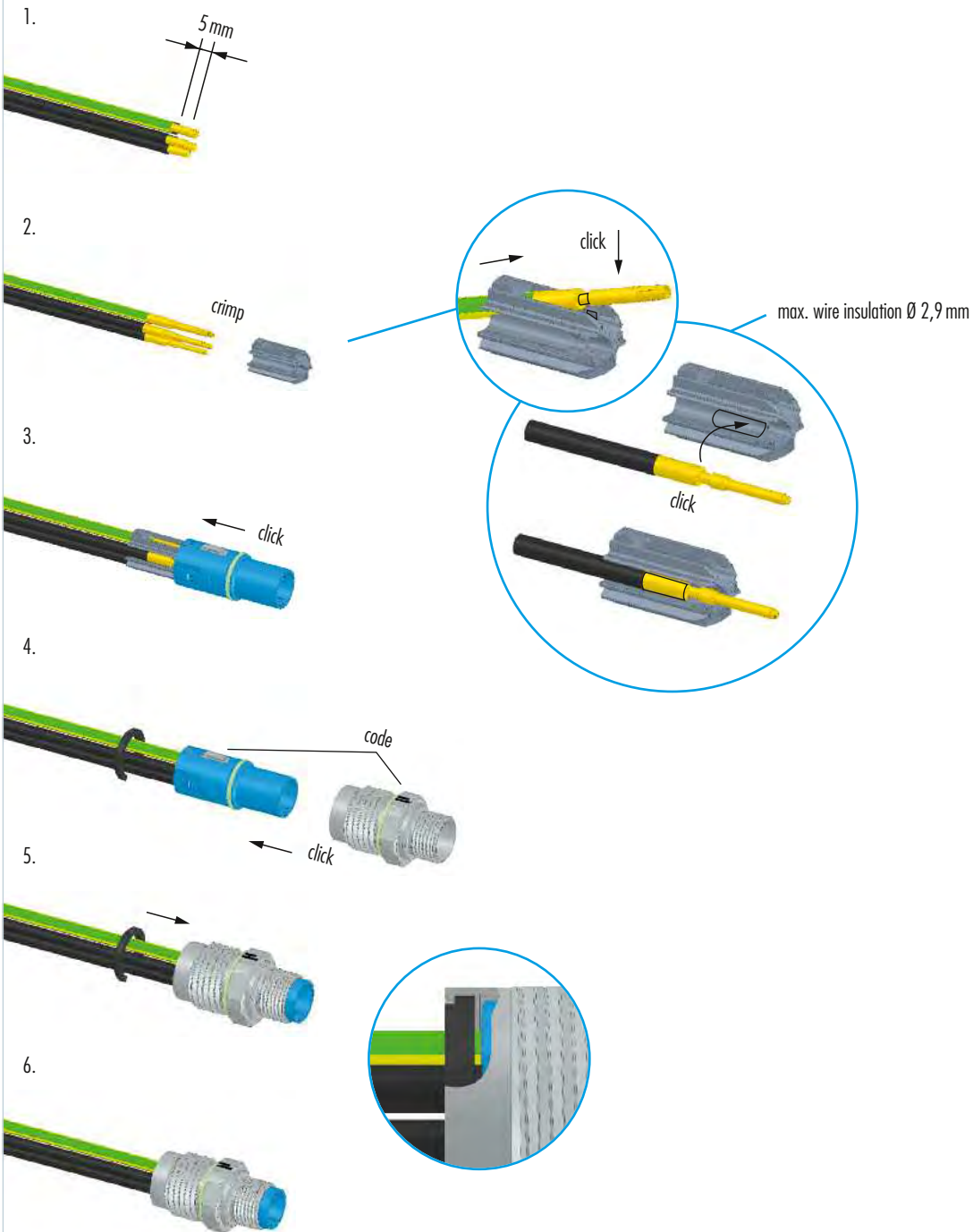

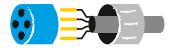

Assembly Instructions

Panel Connector Female / Male Thread, S-/T-Coding

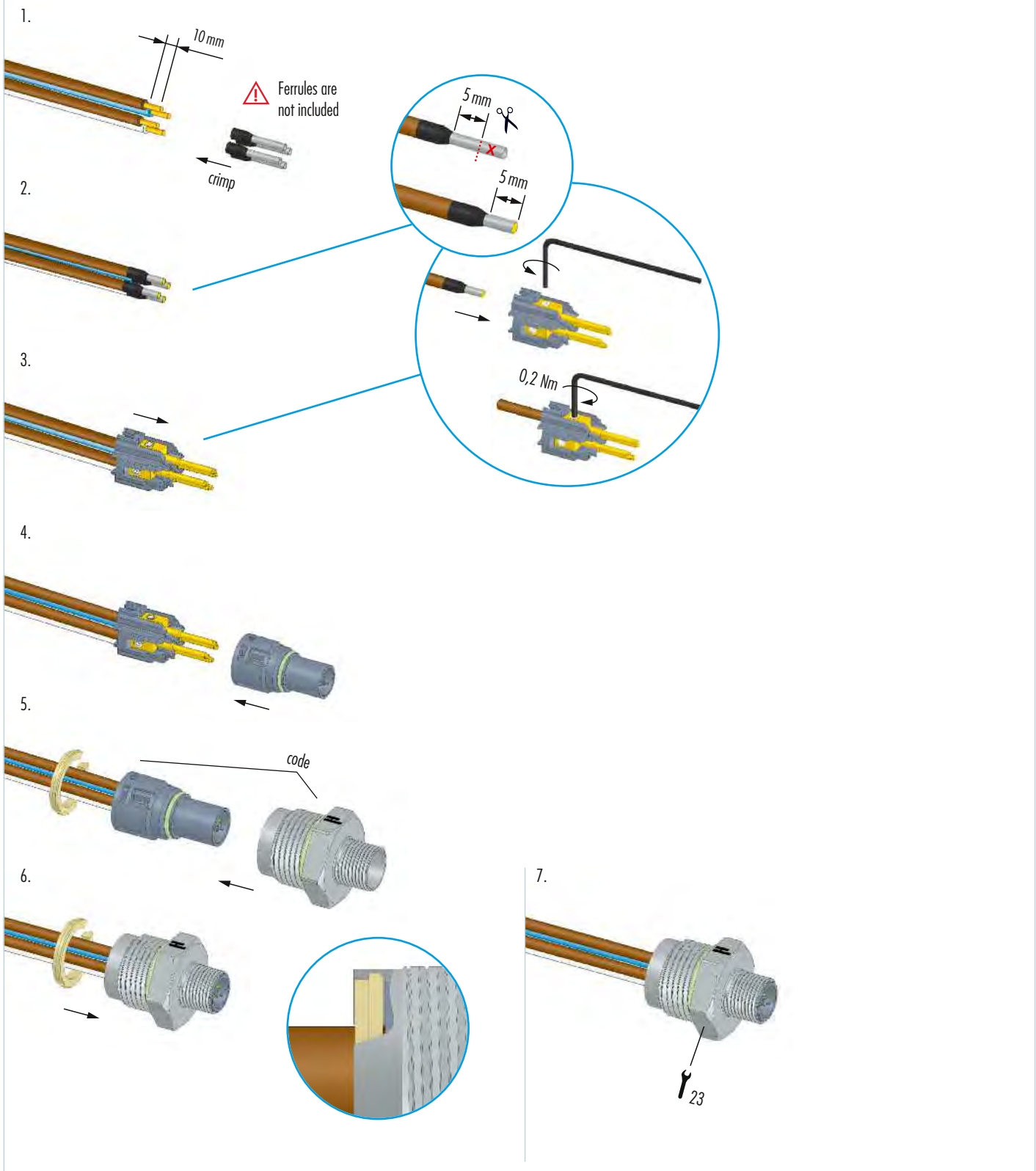

M 16 CONNECTORS

Traditionally M 16 Connectors are very popular with its users. The reason for that is high capability with a low space requirement. A special version is TWINTUS. This compact connector is able to combine signal and power for small drives within one housing.

- // M 16 power connector
- // M 16 signal connector
- // TWILOCK, quick release fastener
- // TWINTUS – Connector 4 small drives



Product overview

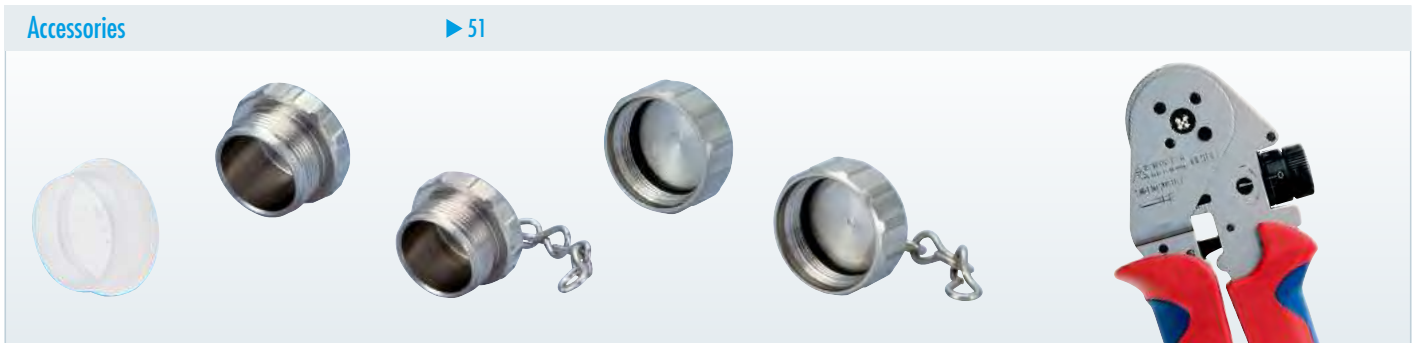
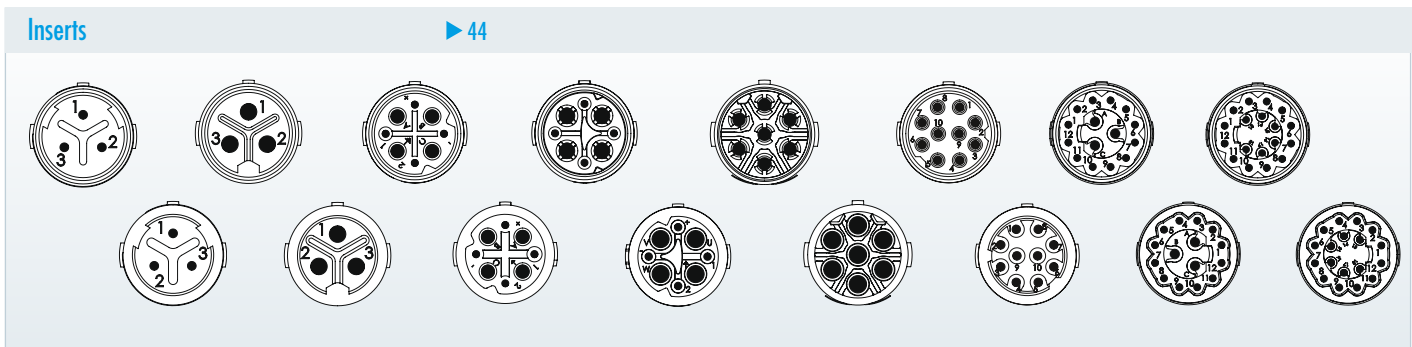

Mechanical Data
Materials and Technical Data

Housing	Copper-Zinc alloy Die Cast
Housing surface	Nickel plated other surface upon request
Inserts (for contacts)	Thermoplastic Polyamid PA 6 (Nylon 6/6), PBT Fire protection class V-0
Contacts	Brass Alloy
Contact surface at point of contact	Nickel and gold plated (0,25 µm)
Minimum mating cycles	> 1000*
Seals / O-Rings	Buna-N standard, optional Viton® (FPM /FKM) (Viton is a registered trademark of DuPont)
Temperature range	-40 °C – 125 °C (-40 °F – 257 °F)
Type of contacts	Crimp, dip-solder (PCB) (for printed circuit boards)
Protection	IP 67 / IP 69K per EN 60 529 (connected), NEMA 4x
Cable diameter range	2 – 11 mm (.08 – .43")

* HUMMEL to HUMMEL connector

Electrical Data

	3 (3 x 1 mm)	3 (3 x 2 mm)	4 + 3 + PE / 320 V		4 + 3 + PE / 600 V	
Number of positions	3	3	4	4	4	4
Number of contacts	3	3	4	4	4	4
Contact-Ø [mm]	1	2	0,8	1,6	0,8	1,25
AWG [mm ²]	0,14 – 1	0,5 – 2,5	0,08 – 0,34	0,34 – 1,5	0,08 – 0,34	0,5 – 1,5
Nominal current ¹⁾ [A]	8	20	5	16	5	16
Nominal voltage ²⁾ [V~] degree of protection 3 ⁴⁾	400	400	160	320	300	600
Test voltage (Breakdown voltage) ³⁾ [V~]	2500	2500	1500	2500	1500	2500
Insulation resistance [Ω]	> 10 ¹⁰	> 10 ¹⁰	> 10 ¹⁰		> 10 ¹⁰	
Max. contact resistance [mΩ]	3	3	3		3	3

Number of positions	6+PE	10	12+3		18
Number of contacts	7	10	12	3	18
Contact-Ø [mm]	1,25	1	0,8	1,25	0,8
AWG [mm ²]	0,5 – 1,5	0,14 – 0,75	0,08 – 0,34	0,5 – 1,5	0,08 – 0,34
Nominal current ¹⁾ [A]	16	8	3	10	3
Nominal voltage ²⁾ [V~] degree of protection 3 ⁴⁾	600	160	24	60	24
Test voltage (Breakdown voltage) ³⁾ [V~]	2500	1500	500	1500	1500
Insulation resistance [Ω]	> 10 ¹⁰	> 10 ⁶	> 10 ¹⁰		> 10 ¹⁰
Max. contact resistance [mΩ]	3	3	3	3	3

1), 2), 3), 4) See Technical Information page 18



Housings

Straight Connector, Female Thread / elongated *

elongated

Cable-Ø	Part Number
3 – 6 mm	7.810.300.000
5 – 9 mm	7.810.400.000
8 – 11 mm	7.810.500.000
* elongated	
3 – 6 mm	7.811.300.000
5 – 9 mm	7.811.400.000
8 – 11 mm	7.811.500.000

▶ 44 |
 ▶ 51 |
 ▶ 57/58

Straight Connector, Female Thread TWILOCK

Cable-Ø	Part Number
3 – 6 mm	7.816.300.000
5 – 9 mm	7.816.400.000
8 – 11 mm	7.816.500.000

▶ 44 |
 ▶ 51 |
 ▶ 57/58

Straight Connector, Male Thread

Cable-Ø	Part Number
3 – 6 mm	7.820.300.000
5 – 9 mm	7.820.400.000
8 – 11 mm	7.820.500.000

▶ 44 |
 ▶ 51 |
 ▶ 57/58

Right Angle Connector with positioning

Cable-Ø	Part Number
3 – 6 mm	7.831.300.000
5 – 9 mm	7.831.400.000
8 – 11 mm	7.831.500.000

▶ 44 |
 ▶ 51 |
 ▶ 59

Housing without inserts and contacts

Panel Connector with built in Cable Strain Relief

Cable-Ø

Part Number

Rear mounting, single hole mounted

2 – 7 mm	7.852.300.000
5 – 9 mm	7.852.400.000

Including jam nut PG 11

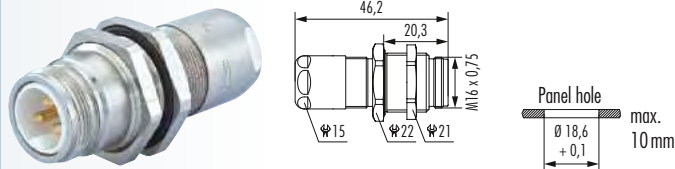

Panel Connector with built in Cable Strain Relief

Cable-Ø

Part Number

Rear mounting, M2,5 x 4 single hole mounted

2 – 7 mm	7.847.300.000
5 – 9 mm	7.847.400.000

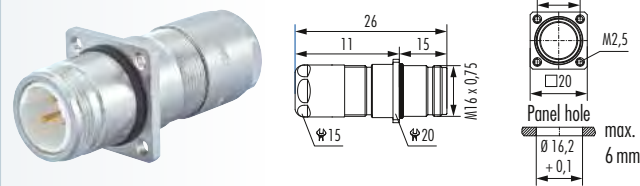

Panel Connector, Male Thread, Front Mounting

Type

Part Number

4 x holes Ø 2,7 mm (.11")	7.840.000.000
Flange 20 x 20 mm		

4 x holes Ø 2,7 mm (.11")	7.840.100.000
Flange 25 x 25 mm		

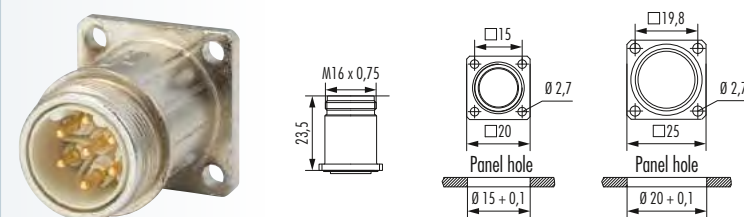

Panel Connector, Male Thread, Front Mounting

Type

Part Number

Short version

4 x holes Ø 2,7 mm (.11")	7.840.200.000
Flange 20 x 20 mm		

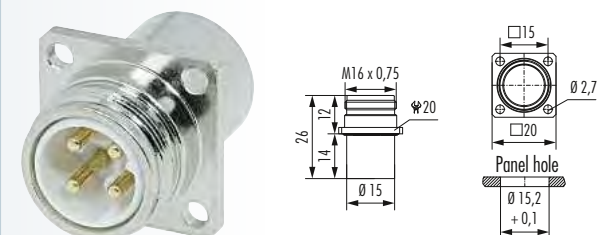

Housing without inserts and contacts



Housings

Right Angle Panel Connector, Male Thread, rotatable

Type	Part Number
300° rotatable, locking screw at flange 4 x holes Ø 2,7 mm (.11")	7.843.000.000
Flange 20 x 20 mm	
4 x holes Ø 2,7 mm (.11")	7.843.100.000
Flange 25 x 25 mm	

Technical drawings show dimensions: 31.7, 28.5, 41.2, 36.5, M16 x 0,75, Ø 2,7, 15, 19.8, 20, 25, Ø 14 + 0,1, Ø 20 + 0,1.

Panel Connector, Male Thread, Front Mounting

Type	Part Number
Front mounting, single hole mounted Thread M 16 x 1,5	7.842.000.000

Technical drawings show dimensions: 31, 25, 6, M16 x 0,75, Ø 19, M16 x 1,5, 15,2 + 0,1, 16,2 + 0,1, Ø 16,2 + 0,1.

Panel Connector, Male Thread, Rear Mounting

Type	Part Number
Rear mounting, single hole mounted Including jam nut	7.850.000.000
Including jam nut PG 11	

Technical drawings show dimensions: 26, 22,5, M16 x 0,75, Ø 21, Ø 22, Ø 24,3, 17,8 + 0,1, 18,6 + 0,1, max. 11 mm, Ø 18,6 + 0,1.

Panel Connector, Male Thread, Rear Mounting

Type	Part Number
Rear mounting, 4 x thread M 2,5 Flange 20 x 20 mm	7.845.000.000

Technical drawings show dimensions: 26, 15, 11, M16 x 0,75, Ø 20, 15, M2,5, 20, 15,2 + 0,1, max. 6 mm, Ø 16,2 + 0,1.

Housing without inserts and contacts



TWINTUS

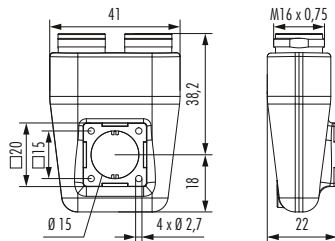

Type

Part Number

Flange 20 x 20 mm

Uncoated.....	7.848.000.000
Surface nickel plated.....	7.848.000.001
Surface black conductive.....	7.848.000.00B



TWINTUS

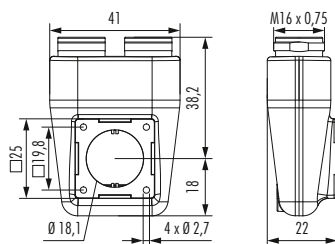

Type

Part Number

Flange 25 x 25 mm

Uncoated.....	7.848.100.000
Surface nickel plated.....	7.848.100.001
Surface black conductive.....	7.848.100.00B



TWINTUS M 16 / M 12

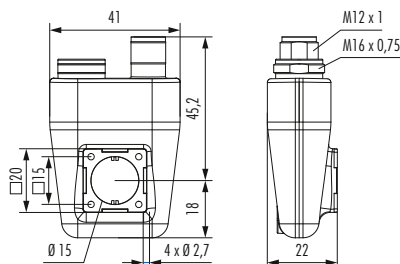

Type

Part Number

Flange 20 x 20 mm

Uncoated.....	7.848.200.000
Surface nickel plated.....	7.848.200.001
Surface black conductive.....	7.848.200.00B



TWINTUS M 16 / M 12

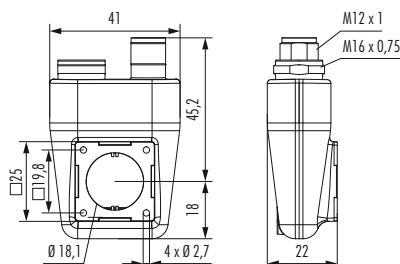

Type

Part Number

Flange 25 x 25 mm

Uncoated.....	7.848.300.000
Surface nickel plated.....	7.848.300.001
Surface black conductive.....	7.848.300.00B



Housing without inserts and contacts



Inserts / Pinouts

Inserts 3-pole (3 x 1 mm)		Type	Part Number	Part Number
<p>Insert pin mating view</p>			Pins	Sockets
	Insert without contacts	7.003.903.101	7.003.903.102
	Insert with dip solder contacts Length 10 mm	7.001.903.127	7.001.903.108
	Insert with dip solder contacts Length 17 mm	7.001.903.137	7.001.903.118
<p>Insert socket mating view</p>	Required Contacts			
	3 x 1 mm	7.010.901.001	7.010.901.002 / 7.010.901.012



Inserts 3-pole (3 x 2 mm)		Type	Part Number	Part Number
<p>Insert pin mating view</p>			Pins	Sockets
	Insert without contacts	7.003.983.101	7.003.983.102
	Insert with dip solder contacts Length 10 mm	7.001.983.127	7.001.983.108
	Insert with dip solder contacts Length 17 mm	7.001.983.137	7.001.983.118
<p>Insert socket mating view</p>	Required Contacts			
	3 x 2 mm	7.010.982.001	7.010.982.002





Inserts 4+3+PE, 320 V

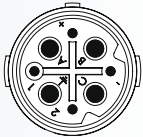

Insert pin mating view

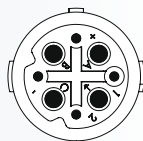

Insert socket mating view

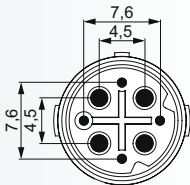

Type	Part Number	Part Number
	Pins	Sockets
Insert without contacts	7.003.943.101	7.003.943.102
Insert RAL 2003 (DESINA orange) without contacts	7.053.943.101	7.053.943.102
Insert with dip solder contacts		
Length 10 mm	7.001.943.127	7.001.943.108
Insert with dip solder contacts		
Length 17 mm	7.001.943.137	7.001.943.118
Required Contacts		
4 x 0,8 mm	7.010.980.801	7.010.980.802
4 x 1,6 mm	7.010.981.601	7.010.981.602



Inserts 4+3+PE, 600 V

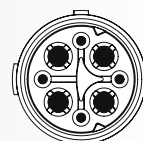

Insert pin mating view

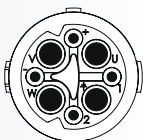

Insert socket mating view

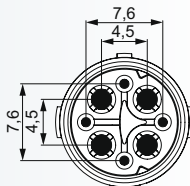

Type	Part Number	Part Number
	Pins	Sockets
Insert without contacts	7.003.908.101	7.003.908.102
Insert RAL 2003 (DESINA orange) without contacts	7.053.908.101	7.053.908.102
Insert with dip solder contacts		
Length 10 mm ¹⁾	7.001.908.127	7.001.908.108
Insert with dip solder contacts		
Length 17 mm ¹⁾	7.001.908.137	7.001.908.118
Required Contacts		
4 x 0,8 mm	7.010.980.811	7.010.980.814
4 x 1,25 mm	7.010.981.211	7.010.981.212



¹⁾ under development

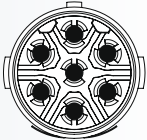
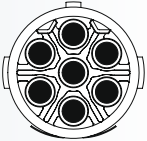
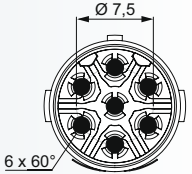

Inserts / Pinouts

Inserts 6+PE		Type	Part Number	Part Number
			Pins	Sockets
 <p>Insert pin mating view</p>	Insert without contacts	7.003.961.101	7.003.961.102	
	Insert RAL 2003 (DESINA orange) without contacts	7.053.961.101	7.053.961.102	
 <p>Insert socket mating view</p>	Insert with dip solder contacts Length 10 mm ¹⁾	7.001.961.127	7.001.961.108	
	Insert with dip solder contacts Length 17 mm ¹⁾	7.001.961.137	7.001.961.118	
	Required Contacts 7 x 1,25 mm	7.010.981.211	7.010.981.212	
				

¹⁾ under development

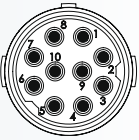
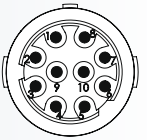
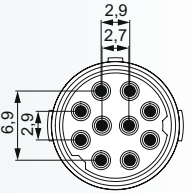

Inserts 10-pole		Type	Part Number	Part Number
			Pins	Sockets
 <p>Insert pin mating view</p>	Insert without contacts	7.003.910.101	7.003.910.102	
	Insert RAL 2003 (DESINA green) without contacts	7.053.910.101	7.053.910.102	
 <p>Insert socket mating view</p>	Insert with dip solder contacts Length 10 mm	7.001.910.127	7.001.910.108	
	Insert with dip solder contacts Length 17 mm	7.001.910.137	7.001.910.118	
	Required Contacts 10 x 1 mm	7.010.981.001	7.010.981.002	
				

¹⁾ under development





Inserts 12+3-pole



Insert pin mating view

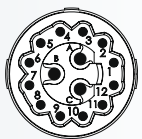

Insert socket mating view

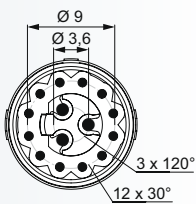

Type	Part Number	Part Number
	Pins	Sockets
Insert without contacts	7.003.985.101	7.003.985.102
Insert with dip solder contacts		
Length 10 mm	7.001.985.127	7.001.985.108
Insert with dip solder contacts		
Length 17 mm	7.001.985.137	7.001.985.118
Required Contacts		
12 x 0,8 mm	7.010.980.801	7.010.980.802
3 x 1,25 mm	7.010.981.201	7.010.981.202



▶ 49 / 50

Inserts 18-pole



Insert pin mating view

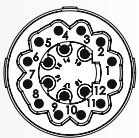

Insert socket mating view

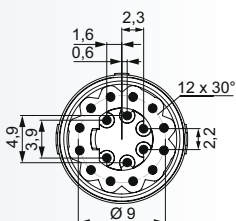

Type	Part Number	Part Number
	Pins	Sockets
Insert without contacts	7.003.988.101	7.003.988.102
Insert RAL 2003 (DESINA green) without contacts.....	7.053.988.101	7.053.988.102
Insert with dip solder contacts		
Length 10 mm	7.001.988.127	7.001.988.108
Insert with dip solder contacts		
Length 17 mm	7.001.988.137	7.001.988.118
Required Contacts		
18 x 0,8 mm	7.010.980.801	7.010.980.802



▶ 49 / 50













Inserts / Pinouts

Inserts M 12 for TWINTUS M 16 / M 12 (8-poles)	Type	Part Number
 <p data-bbox="351 548 510 593">Insert pin mating view</p>	<p data-bbox="941 470 1484 537">Insert with solder contactsA712-7.001.908.103</p>	<p data-bbox="1436 470 1484 504">Pins</p>

Inserts M 12 for TWINTUS M 16 / M 12 (12-poles)	Type	Part Number
 <p data-bbox="351 985 510 1030">Insert pin mating view</p>	<p data-bbox="941 929 1484 974">Insert with solder contactsA712-7.001.912.103</p>	<p data-bbox="1436 907 1484 940">Pins</p>

Contacts

Contacts	Type	Crimp Range	Part Number
	Crimp pin 0,8 mm, machined	0,08 – 0,34 mm ² (AWG 28 – 22)	7.010.980.801
	Crimp socket 0,8 mm, machined	0,08 – 0,34 mm ² (AWG 28 – 22)	7.010.980.802
	Crimp pin 0,8 mm, machined.....	0,08 – 0,34 mm ² (AWG 28 – 22)	7.010.980.811
	Crimp socket 0,8 mm, machined	0,08 – 0,34 mm ² (AWG 28 – 22)	7.010.980.814
	Crimp pin 1 mm, machined.....	0,08 – 0,75 mm ² (AWG 28 – 18)	7.010.981.001
	Crimp socket 1 mm, machined.....	0,08 – 0,75 mm ² (AWG 28 – 18)	7.010.981.002
	Crimp pin 1 mm, machined	0,14 – 1 mm ² (AWG 26 – 17)	7.010.901.001
	Crimp socket 1 mm, machined.....	0,08 – 0,56 mm ² (AWG 28 – 20)	7.010.901.012
	Crimp socket 1 mm, machined	0,34 – 1 mm ² (AWG 22 – 17)	7.010.901.002
	Crimp pin 1,25 mm, machined.....	0,5 – 1,5 mm ² (AWG 20 – 16)	7.010.981.201
	Crimp socket 1,25 mm, machined	0,5 – 1,5 mm ² (AWG 20 – 16)	7.010.981.202







▶ 53 / 54



▶ 62

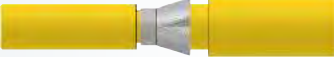

Contacts

Contacts	Type	Crimp Range	Part Number
	Crimp pin 1,25 mm, machined.....	0,34 – 1,5 mm ² (AWG 20 – 16)	7.010.981.211
	Crimp socket 1,25 mm, machined	0,34 – 1,5 mm ² (AWG 20 – 16)	7.010.981.212
	Crimp pin 1,6 mm, machined	0,34 – 1,5 mm ² (AWG 22 – 16)	7.010.981.601
	Crimp socket 1,6 mm, machined	0,34 – 1,5 mm ² (AWG 22 – 16)	7.010.981.602
	Crimp pin 2 mm, machined.....	1,0 – 2,5 mm ² (AWG 17 – 14)	7.010.982.001
	Crimp socket 2 mm, machined.....	1,0 – 2,5 mm ² (AWG 17 – 14)	7.010.982.002



Accessories

Accessories	Type	Part Number
	Plastic protective cap for connectors with male thread7.000.980.161 with female thread7.000.980.162	
	Brass protective cap for connectors with female thread7.010.900.163 ¹	
	Brass protective cap for connectors with male thread7.010.900.162	
	Brass protective cap with chain for connectors with female thread Length 70 mm7.010.950.705 ¹	
	Brass protective cap with chain for connectors with male thread Length 70 mm7.010.950.704	
	Crimp tool for manual crimping of machined crimp contacts for signal connectors M 16 and M 237.000.900.904	
	▶ 53 / 54 ▶ 106	
	Adaptor flange for Straight Connectors7.010.900.135	

¹ no compatibility with TWILOCK



Accessories

Accessories	Type	Part Number
	Conduit adaptor	
	Poleon DN 10	7.010.900.200
	Poleon DN 12	7.010.900.202
	Plastic protective cap for TWINTUS	
	TWINTUS M 16	7.000.848.101
	TWINTUS M 16 / M 12	7.000.848.102
	Disassembly Tool	
	for crimp contacts 1,25 mm	7.010.900.151
	Tool Adapter for tightening or loosening	
	knurled nuts for M 12 Power/M 16	7.010.900.191
	Screw Tool, adjustable 0.5 – 1.7 Nm	
	7.010.900.190

¹ upon request

Crimp Tool Setting for HUMMEL Crimp Contacts (Crimp Tool 7.000.900.904)

Part Number	Crimp Contact	Cross Section (mm ²)	AWG	Crimp Tool Setting mm	Locator Setting
7.010.980.801	Crimp pin 0,8 mm	0,08	AWG 28	0,57	10
		0,14	AWG 26	0,60	
		0,25	AWG 24	0,64	
		0,34	AWG 22	0,73	
7.010.980.802	Crimp socket 0,8 mm	0,08	AWG 28	0,57	10
		0,14	AWG 26	0,60	
		0,25	AWG 24	0,64	
		0,34	AWG 22	0,73	
7.010.980.811	Crimp pin 0,8 mm	0,08	AWG 28	0,57	B7
		0,14	AWG 26	0,60	
		0,25	AWG 24	0,64	
		0,34	AWG 22	0,73	
7.010.980.814	Crimp socket 0,8 mm	0,08	AWG 28	0,57	B8
		0,14	AWG 26	0,60	
		0,25	AWG 24	0,64	
		0,34	AWG 22	0,73	
7.010.981.001	Crimp pin 1 mm	0,08	AWG 28	0,60	7
		0,14	AWG 26	0,65	
		0,25	AWG 24	0,67	
		0,34	AWG 22	0,71	
		0,56	AWG 20	0,75	
		0,75	AWG 18	0,82	
7.010.981.002	Crimp socket 1 mm	0,08	AWG 28	0,60	8
		0,14	AWG 26	0,63	
		0,25	AWG 24	0,66	
		0,34	AWG 22	0,69	
		0,56	AWG 20	0,75	
		0,75	AWG 18	0,83	
7.010.901.001	Crimp pin 1 mm	0,14	AWG 26	0,70	1
		0,25	AWG 24	0,76	
		0,34	AWG 22	0,82	
		0,50	AWG 20	0,90	
		0,75	AWG 18	1,00	
		1,0	AWG 17	1,10	
7.010.901.012	Crimp socket 1 mm (0,08- - 0,56 mm ²)	0,08	AWG 28	0,75	2
		0,14	AWG 26	0,78	
		0,25	AWG 24	0,82	
		0,34	AWG 22	0,86	
		0,56	AWG 20	0,90	



These values are only guidelines and actual conductor cross sections depend on manufacturer tolerances.



Crimp Tool Setting for HUMMEL Crimp Contacts (Crimp Tool 7.000.900.904)

Part Number	Crimp Contact	Cross Section (mm ²)	AWG	Crimp Tool Setting mm	Locator Setting
7.010.901.002	Crimp socket 1 mm (0,34 – 1 mm ²)	0,34	AWG 22	0,77	2
		0,56	AWG 20	0,82	
		0,75	AWG 18	0,88	
		1,0	AWG 17	0,95	
7.010.981.201	Crimp pin 1,25 mm	0,5	AWG 20	0,70	2
		0,75	AWG 18	0,73	
		1,0	AWG 17	0,79	
		1,5	AWG 16	0,88	
7.010.981.202	Crimp socket 1,25 mm	0,5	AWG 20	0,70	2
		0,75	AWG 18	0,73	
		1,0	AWG 17	0,79	
		1,5	AWG 16	0,88	
7.010.981.211	Crimp pin 1,25 mm	0,34	AWG 22	0,80	B9
		0,5	AWG 20	0,84	
		0,75	AWG 18	0,90	
		1,0	AWG 17	1,00	
7.010.981.212	Crimp socket 1,25 mm	0,34	AWG 22	1,00	B10
		0,5	AWG 20	1,04	
		0,75	AWG 18	1,10	
		1,0	AWG 17	1,20	
7.010.981.601	Crimp pin 1,6 mm	0,34	AWG 22	0,80	6
		0,56	AWG 20	0,84	
		0,75	AWG 18	0,90	
		1,0	AWG 17	1,00	
7.010.981.602	Crimp socket 1,6 mm	0,34	AWG 22	0,83	9
		0,56	AWG 20	0,90	
		0,75	AWG 18	0,97	
		1,0	AWG 17	1,02	
7.010.982.001	Crimp pin 2 mm	1,0	AWG 17	1,35	4
		1,5	AWG 16	1,45	
		2,5	AWG 14	1,60	
7.010.982.002	Crimp socket 2 mm	1,0	AWG 17	1,35	5
		1,5	AWG 16	1,45	
		2,5	AWG 14	1,60	



These values are only guidelines and actual conductor cross sections depend on manufacturer tolerances.



TWINTUS

1.

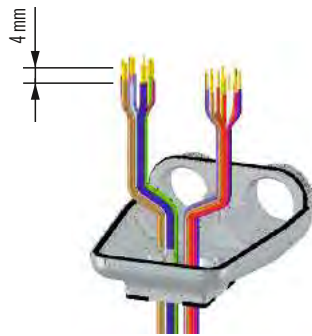

2.

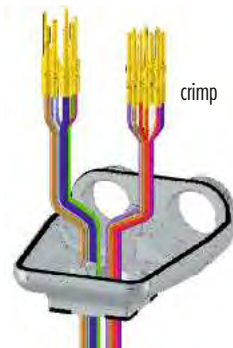

3.

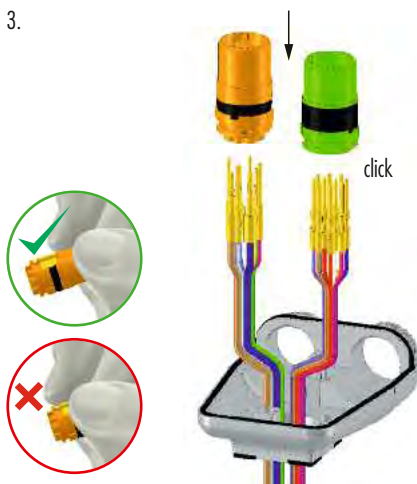

4.

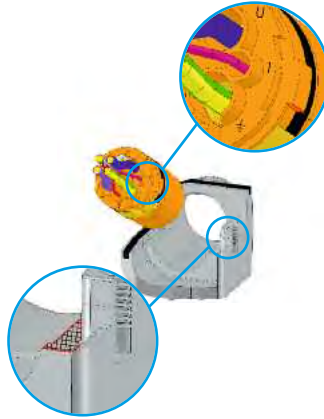

5.

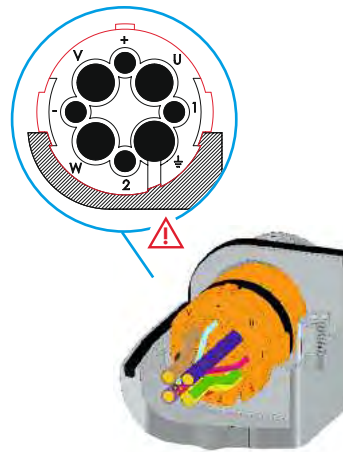

6.



7.

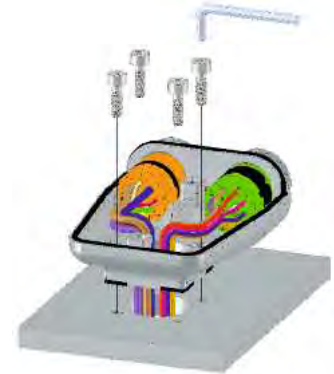

8.



9.

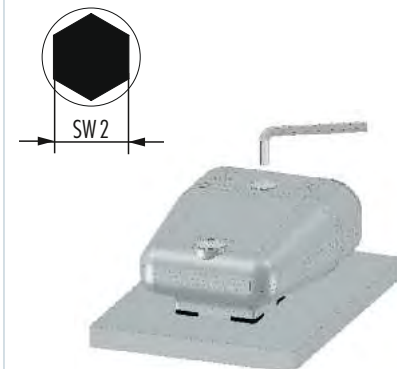

M 12

M 16

M 23 PoE

M 23 RJ 45

M 23 Signal

M 27 Signal

M 23 Power

M 40 Power

INOX

Moulded Cordsets

Customized



Assembly Instructions

TWINTUS M 16 / M 12

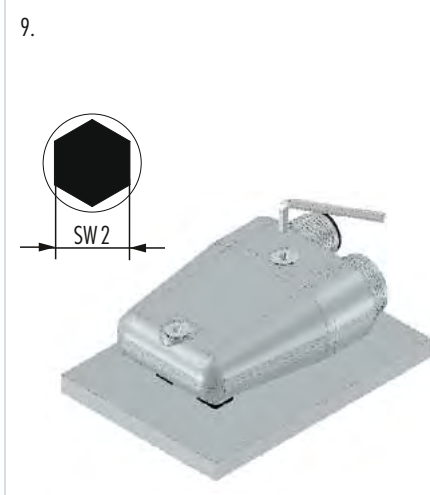
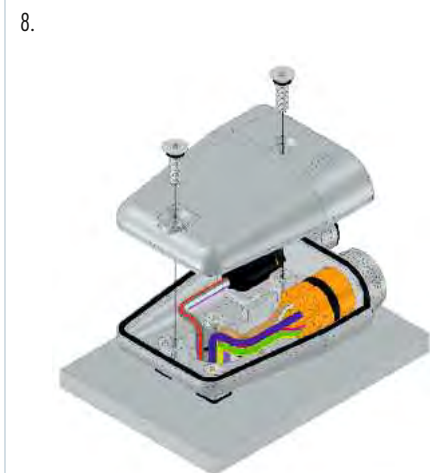
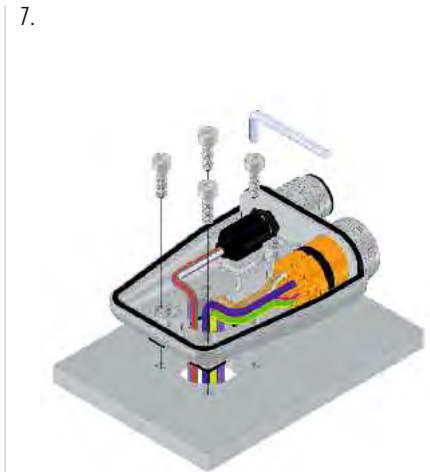
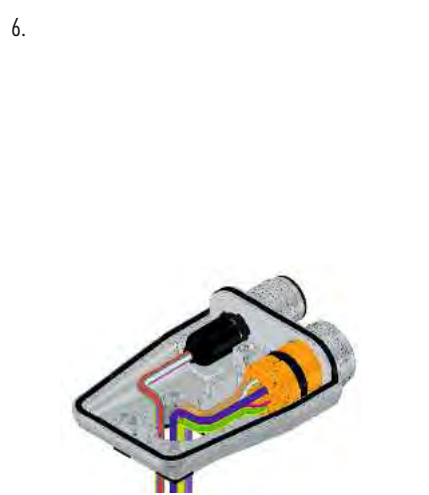
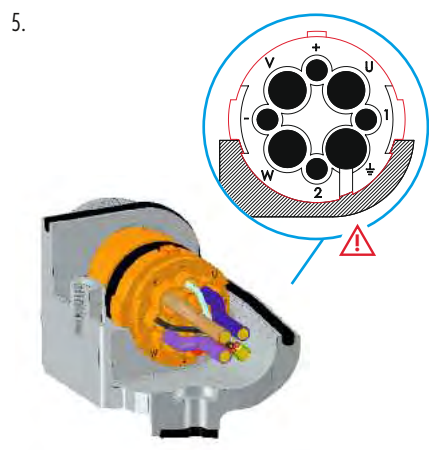
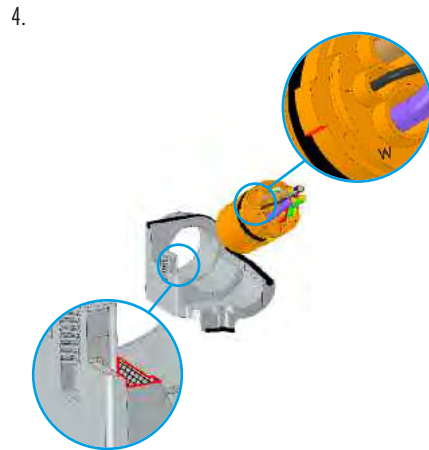
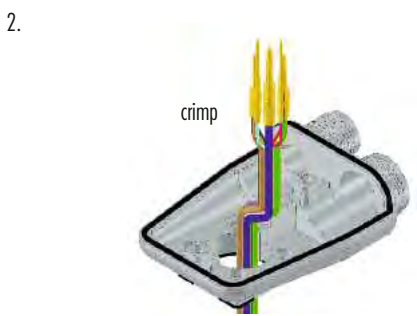
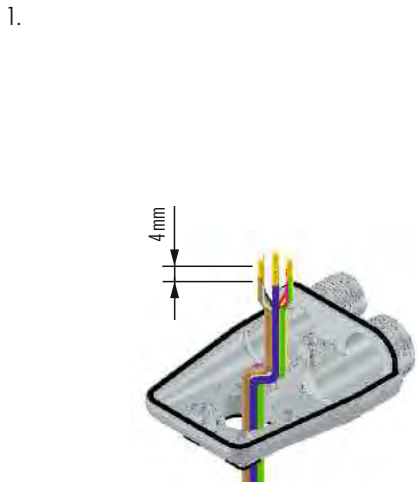



Female Threaded Connector / Male Threaded Connector

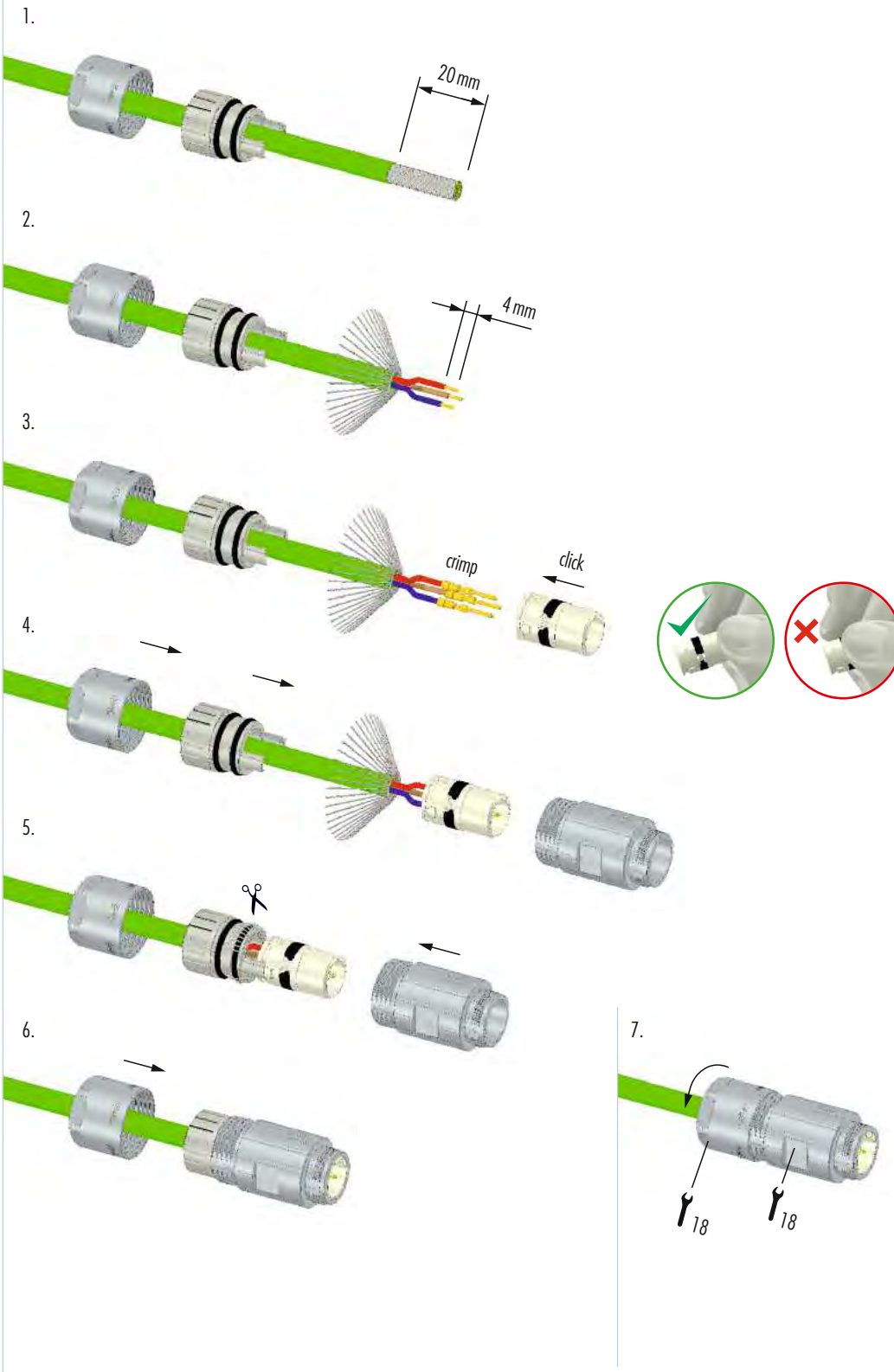

M 12

M 16

M 23 PoE

M 23 RJ45

M 23 Signal

M 27 Signal

M 23 Power

M 40 Power

INOX

Moulded Cordsets

Customized



Assembly Instructions

Female Threaded Connector / Male Threaded Connector 12 + 3

1. 25 mm
2. 4 mm
3. crimp
4. click
5. click
- 6.
- 7.
8. 15/18 15/18

Warning: The inner conductors (bigger cross section for middle insert) shorten appr. 2–3 mm

Click: click

Correct/Incorrect:



Right angle connector with positioning

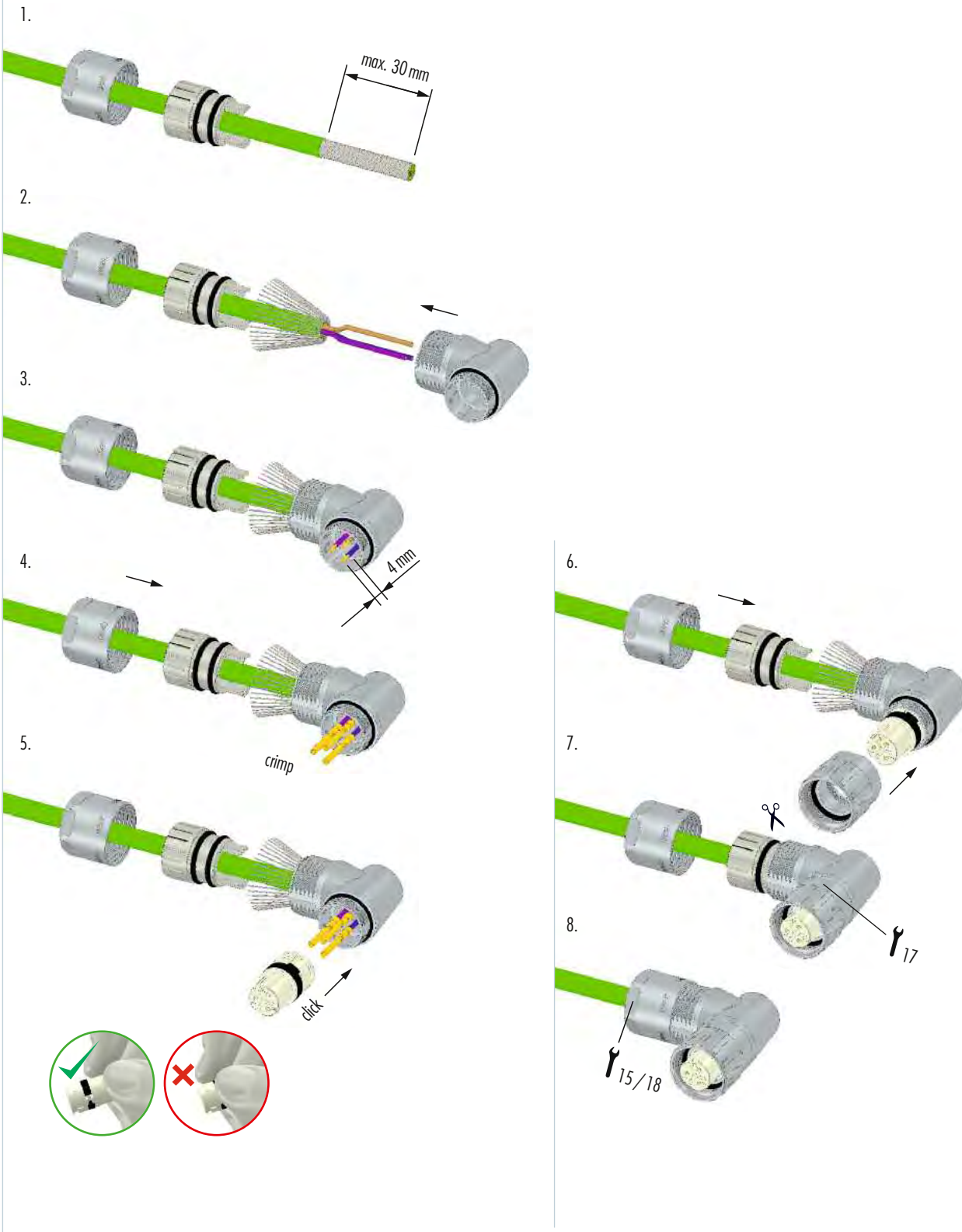



Assembly Instructions

Panel Connector

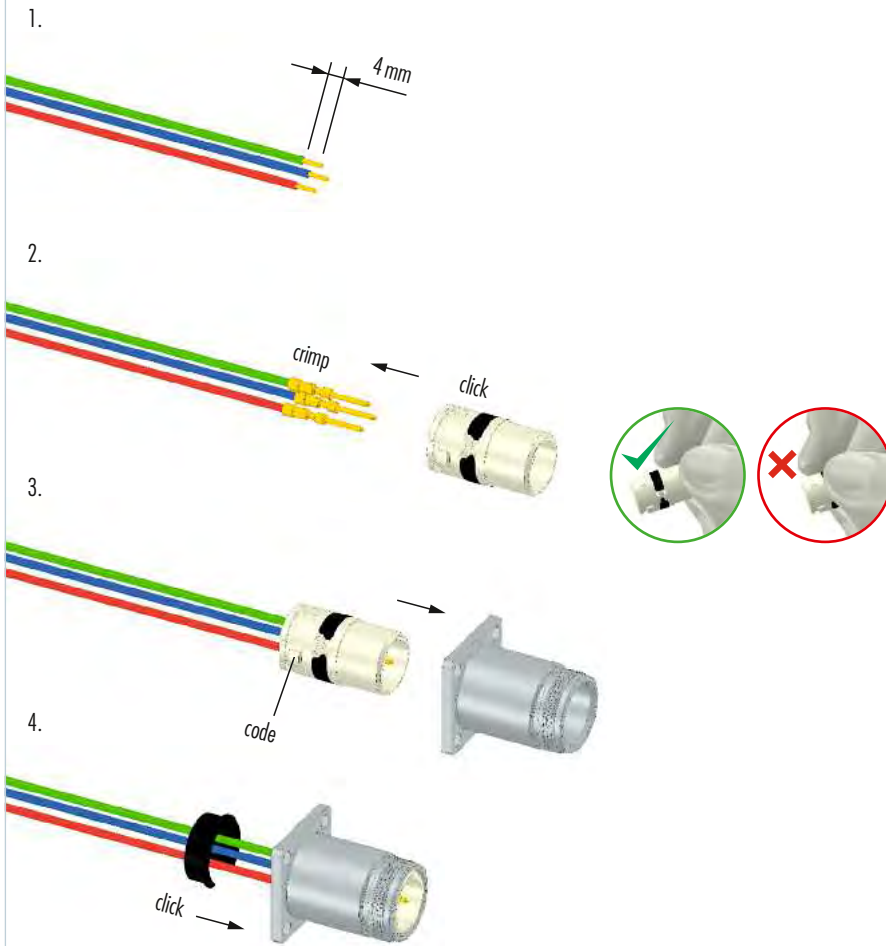



Right Angle Panel Connector

1.

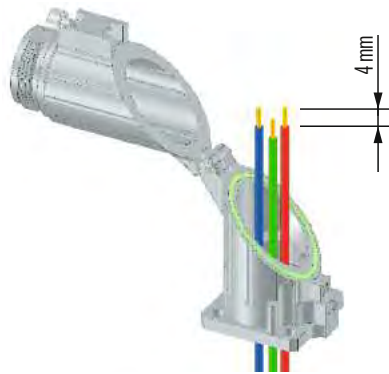

2.

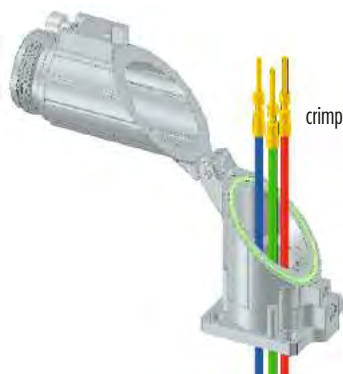

3.

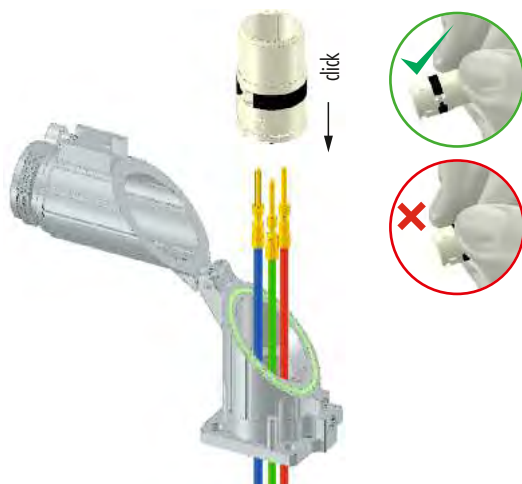

4.

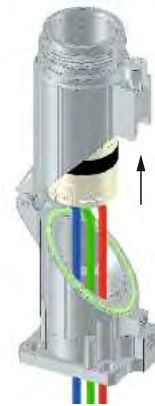

5.

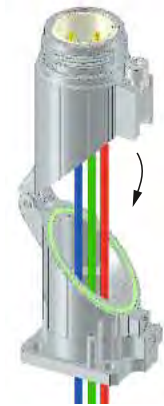

6.

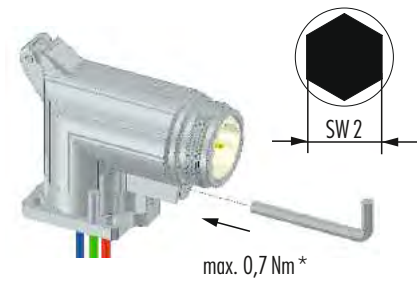

7.

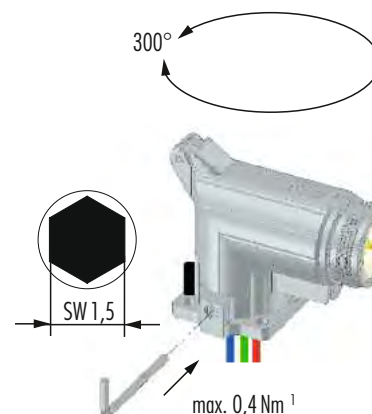

¹ max. torque



Crimping, Assembly and Disassembly of Contacts

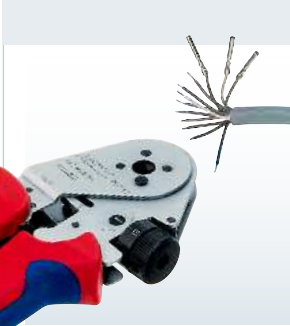

Crimping

- Remove conductor insulation 4 mm (.16") max.
- // Select appropriate Crimp tool setting
- // Push crimp contact into opening of crimping tool
- // Insert stripped wire into the funnel shaped end of the crimp contact
- // Squeeze handles of crimping tool together connect contact to wire

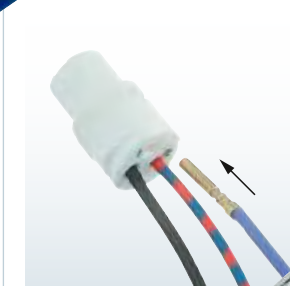

Assembly

- Remove crimped assembly and pull on wire to test connection
- // Push into desired position of insert

Disassembly of Contacts from Insert

A small screwdriver is needed to remove the contacts from the insert.

- // Release the white ring by a screwdriver out of the insert
- // Move the misplaced contacts out of the insert
- // Enter the ring back into the insert
- // Push the contacts back into insert

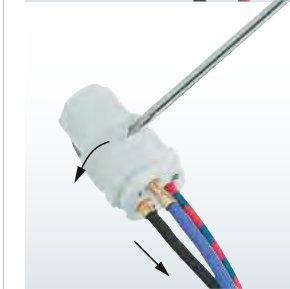

Shielding

- Assemble strain relief insert with insert
- // Fold stranding of the shield back over the first O-Ring of the strain relief insert
- // Cut back the overextending braid



Warning: The shield of the shield is not allowed to touch the second O-Ring.



M 23 FAST ETHERNET PoE

This connector is able to transfer data up to Gigabit range. The M 23 Fast Ethernet PoE is robust, safe and compact. It is designed for use in rough industrial environments.

- // Hybrid connectors for single cable solution
- // Four Twinax-Inserts for data transfer
- // Five separate shieldings prevent cross talk
- // Highest density within M 23 housing



Product overview



Mechanical Data	Materials and Technical Data
Housing	Copper-Zinc alloy Die Cast
Housing surface	Nickel plated
Inserts (for contacts)	PBT UL-94 V0, PA6
Contacts	Brass Alloy
Contact surface at point of contact	Nickel and gold plated (0,25 µm)
Minimum mating cycles	> 1000
Seals / O-Rings	Perbunan NBR (Standard)
Temperature range	-40 °C – 125 °C (-40 °F – 257 °F)
Type of contacts	Crimp, dip-solder (PCB)
Protection	IP 67 per EN 60 529 (connected), NEMA 4x
Cable diameter range	11 – 17 mm (.43" – .67")

Electrical Data		
Number of positions	20 (4 x 2 + 12)	
Number of contacts	4 x 2	12
Contact-Ø [mm]	0,6	1
AWG [mm ²]	0,08 – 0,34	0,14 – 1 / 1,5
Nominal current ¹⁾ [A]	2	8*
Nominal voltage ²⁾ [V~] degree of protection 3 ⁴⁾	60	160
Test voltage (Breakdown voltage) ³⁾ [V~]	500	1500
Insulation resistance [Ω]	> 10 ⁶	> 10 ⁶
Max. contact resistance [mΩ]	3	3
Impedance [Ω] (at 100MHz)	100	–

^{1), 2), 3), 4)} See Technical Information page 18 // * for single contacts even 10A possible



Housings

Straight Female Connector

Cable-Ø	Part Number
11-17 mm	7.108.600.000

Straight Connector, Male Thread

Cable-Ø	Part Number
11-17 mm	7.208.600.000

Right Angle Connector, Female Thread, rotatable

Cable-Ø	Part Number
11-17 mm	7.308.600.000

Panel Connector, Male Thread, Front Mounting

Type	Part Number
4 x holes Ø 2,7 mm (.11")	7.408.000.000
Flange 26 x 26 mm	

Housing without inserts and contacts

Panel Connector, Rear Mounting

Type

Part Number

4 x holes $\varnothing 3,2$ mm (.13")7.468.000.000
Flange 26 x 26 mm

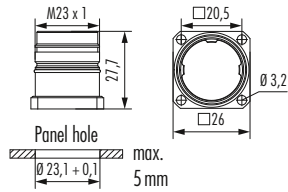





Housing without inserts and contacts

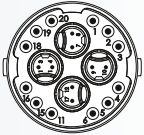
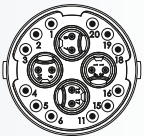

Inserts / Pinouts / Contacts





Inserts (4 x 2) + 12		Type	Part Number	Part Number
 <p>Insert pin mating view</p>			Pins	Sockets
	Insert without contacts	7.003.920.101	7.003.920.102	7.003.920.102
 <p>Insert socket mating view</p>	Insert with dip solder contacts.....	7.001.920.107	7.001.920.108	7.001.920.108
	Required Contacts			
	8 x 0,6	7.010.980.641	7.010.980.602	7.010.980.602
	12 x 1	7.010.901.045	7.010.901.002	7.010.901.002
		7.010.901.049	7.010.901.012	7.010.901.012
			7.010.901.022	7.010.901.022
			7.010.901.046	7.010.901.046

Contacts	Type	Crimp Range	Part Number
	Crimp pin 0,6 mm, machined	0,08 – 0,34 mm ²	7.010.980.641
	Crimp socket 0,6 mm, machined.....	0,08 – 0,34 mm ²	7.010.980.602
	Crimp pin 1 mm, machined	0,14 – 1 mm ²	7.010.901.049
		0,75 – 1,5 mm ²	7.010.901.045
	Crimp socket 1 mm, machined.....	0,08 – 0,56 mm ²	7.010.901.012
		0,34 – 1 mm ²	7.010.901.002
		0,75 – 1,5 mm ²	7.010.901.022
		1 – 1,75 mm ²	7.010.901.046

Accessories	Type	Part Number
	Plastic protective cap for connectors with male thread	7.000.900.101
	with female thread	7.000.900.102
	Brass protective cap for connectors with female thread	7.010.900.183
	Brass protective cap with chain for connectors with female thread Length 70 mm	7.010.950.783
	Length 100 mm	7.010.951.083
	Brass protective cap for connectors with male thread	7.010.908.102
	Conduit adaptor Poleon DN 12	7.010.900.205
	Poleon DN 14	7.010.900.207
	Poleon DN 17	7.010.900.209
	Adaptor flange for Straight Connectors	7.010.900.128
	Adaptor flange for moulded connectors	7.010.900.139
	Multi-Bus adapter wired through I:I (excentric) Multi-Bus I, Female Thread, Sockets 17pole Multi-Bus II, Male Thread, Pins	7.010.900.143
	Multi-Bus I, Female Thread, Pins, 17pole Multi-Bus II, Male Thread, Sockets	7.010.900.144



Accessories

Accessories	Type	Part Number
	Control Cabinet adapter for Multibus II – AIDA Rear Mounting, central locking	7.010.900.145
	I/O adapter module to scan or feed signals Rear Mounting, central locking	7.010.900.146
	Manual Crimp tool for EMC sleeves M 23 Fast Ethernet	7.000.900.906
	Manual Crimp tool for turned contacts M 23 Fast Ethernet	7.000.900.907
	▶108	



Crimp Tool Settings for HUMMEL Crimp Contacts (Crimp Tool 7.000.900.907)

Part Number	Crimp Contact	Cross Section (mm ²)	AWG	Crimp Tool Setting mm	Locator Setting
7.010.980.641	Crimp pin 0,6 mm (0,08 – 0,34 mm ²)	0,08	AWG 28	0,57	B 1
		0,14	AWG 26	0,60	
		0,25	AWG 24	0,64	
		0,34	AWG 22	0,73	
7.010.980.602	Crimp socket 0,6 mm (0,08 – 0,34 mm ²)	0,08	AWG 28	0,57	B 2
		0,14	AWG 26	0,60	
		0,25	AWG 24	0,64	
		0,34	AWG 22	0,73	
7.010.901.049	Crimp pin 1 mm (0,14 – 1,0 mm ²)	0,14	AWG 26	0,70	B 3
		0,25	AWG 24	0,76	
		0,34	AWG 22	0,82	
		0,56	AWG 20	0,90	
		0,75	AWG 18	1,00	
7.010.901.045	Crimp pin 1 mm (0,75 – 1,5 mm ²)	0,75	AWG 18	0,80	B 5
		1,00	AWG 17	0,85	
		1,50	AWG 16	0,95	
7.010.901.012	Crimp socket 1 mm (0,08 – 0,56 mm ²)	0,08	AWG 28	0,75	B 4
		0,14	AWG 26	0,78	
		0,25	AWG 24	0,82	
		0,34	AWG 22	0,88	
		0,56	AWG 20	0,90	
7.010.901.002	Crimp socket 1 mm (0,34 – 1,0 mm ²)	0,34	AWG 22	0,77	B 4
		0,56	AWG 20	0,82	
		0,75	AWG 18	0,88	
		1,00	AWG 17	0,95	
7.010.901.022	Crimp socket 1 mm (0,75 – 1,5 mm ²)	0,75	AWG 18	0,80	B 4
		1,00	AWG 17	0,86	
		1,50	AWG 16	0,95	
7.010.901.046	Crimp socket 1 mm (1 – 1,75 mm ²)	1,00	AWG 17	0,85	B 6
		1,50	AWG 16	0,95	
		1,75	AWG 15	1,00	

These values are only guidelines and actual conductor cross sections depend on manufacturer tolerances.



Assembly Instructions

Straight Connector Male / Female Thread

1. x 17 mm

2. y

3. z max. 4,5 mm

4. max. 4 mm

5. crimp

6. crimp

7. click

8. click

9. crimp

7.000.900.906

x	Pins = 41 mm Sockets = 37 mm
y	Pins = 7 mm Sockets = 0 mm
z	Pins = 10 mm Sockets = 7 mm

10. code + position

11.

12. click

13. click

14. click

15. click

16. 24 24



Panel Connector

1. max. 4,5 mm
2. max. 4 mm

! Pins = 10 mm
Sockets = 7 mm

3. crimp
4. crimp
5. click
6. click
7. crimp

7.000.900.906

8. code + position

9. code
10. click
11. click
12. code

M 12
M 16
M 23 PoE
M 23 RJ 45
M 23 Signal
M 27 Signal
M 23 Power
M 40 Power
INOX
Moulded Cordsets
Customized



Assembly Instructions

Right Angle Connector

1. Strip the cable to 80 mm total length, with 55 mm of the outer jacket removed.
2. Prepare the inner jacket and shield.
3. Strip the individual conductors to a maximum length of 4.5 mm.
4. Strip the conductors to a maximum length of 4 mm.
5. Crimp the conductors onto the pins (x).
6. Crimp the shield onto the socket (y).
7. Click the conductors into the connector housing.
8. Click the shield into the connector housing.
9. Crimp the connector housing onto the cable using crimping pliers (7.000.900.906).
10. Prepare the second cable with the correct code and position.
11. Identify the code and position of the pins on the second cable.
12. Align the second cable with the first connector.
13. Click the second cable into the connector housing. (Green checkmark indicates correct alignment, red X indicates incorrect).
14. Tighten the connector housing with a 27mm wrench.
15. Trim the excess cable length with scissors.
16. Tighten the connector housing with a 24mm wrench.
17. Tighten the connector housing with a 25mm wrench.

x Pins = 7 mm
Sockets = 0 mm

y Pins = 10 mm
Sockets = 7 mm

M 23 RJ 45 CONNECTORS

The connector series M 23 RJ 45 stands for safe data transfers with smallest space requirement in rough industrial environments. Here industrial patch cable can be used that the M 23 RJ 45 integrates in the body of an adaptor. The system achieves an excellent strain relief and complies with the protection class IP 67.

- // Industry suited system for safe data transfer
- // Integration of industrial patch cable
- // Screw lock
- // Suitable as maintenance interface



Product overview

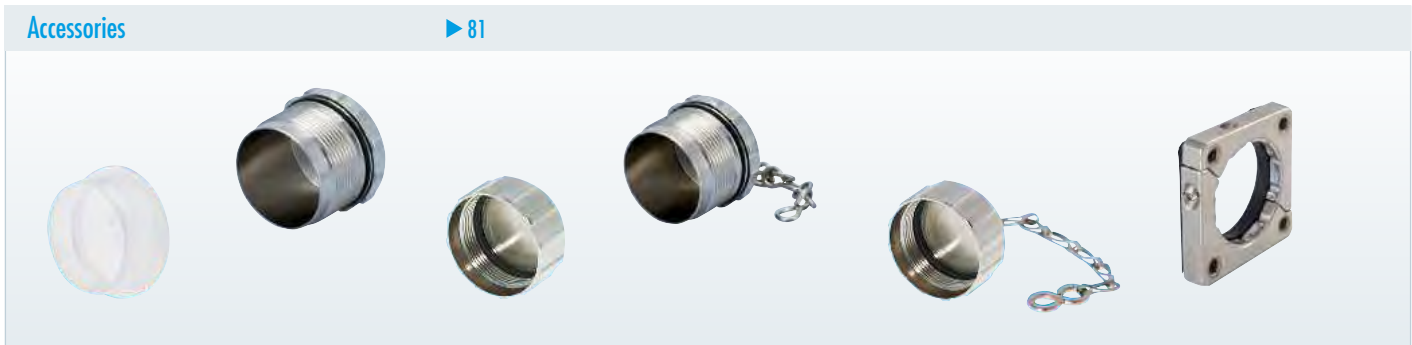

Mechanical Data	Materials and Technical Data
Housing	Brass Alloy, Die Cast
Housing Surface	Nickel Plated
Inserts (for contacts)	PBT UL-94 V0, PA 6
Contacts	Brass Alloy
Contact Surface at point of contact	Depends on RJ 45 type used
Seals / O-Rings	NBR Viton® (FKM / FPM)
Temperature Range	Depends on RJ 45 type used
Degree of Protection	IP 67 per EN 60529 (mated)
Cable diameter range	3 – 7 / 7 – 12 / 11 – 17mm
Number of Positions	4 / 6 / 8 poles, optional 4 + 2 / 6 + 2 / 8 + 2
Nominal Current ¹⁾ [A]	Depends on RJ 45 type used
Nominal Voltage ²⁾ [V~]	Depends on RJ 45 type used
Test Voltage [V~]	Depends on RJ 45 type used
Insulation Resistance [Ω]	Depends on RJ 45 type used
Max. Crossover Resistance [mΩ]	Depends on RJ 45 type used
Max. Data Rate	Depends on RJ 45 type used, IAW Cat 5/5e/6a

^{1), 2)} see Technical Information page 18



Housings

Straight Connector Female Thread

Cable-Ø	Part Number
3 – 7 mm (.12 - .28")	7.R10.400.000

Connector with insert for patch cable

Suitable patch cable and plugs can be recommended.

Straight Connector Male Thread

Cable-Ø	Part Number
3 – 7 mm (.12 - .28")	7.R20.408.000

Incl. 8 poles coupler, fully occupied

Panel Connector Front Mount, dip solder insert

Type	Part Number
4 holes 2.7 mm, Flange Incl. 8 poles dip solder insert	7.R40.008.000
4 holes 2.7 mm, Flange Incl. 8 + 2 poles dip solder insert	7.R40.082.000

Panel Connector, Front Mount

Type	Part Number
with vibration protection 4 holes 2.7 mm, Flange Incl. 8 poles coupler, fully occupied	7.R41.008.000

Single Hole Panel Connector

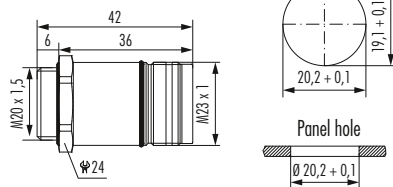

Type

Part Number

Front Mount

M 20 x 1,5 thread7.R42.008.000
Incl. 8 poles coupler, fully occupied

Optional: Gasket M 20 x 1,5, Locking Nut



▶ 81

Single Hole Panel Connector

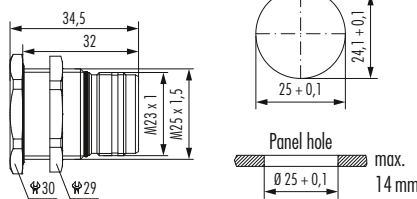

Type

Part Number

Rear Mount

M 25 x 1,5 thread7.R50.008.000
Incl. 8 poles coupler, fully occupied

M 25 x 1,5 Locking Nut included.



▶ 81

Right Angle Panel Connector, Male Thread

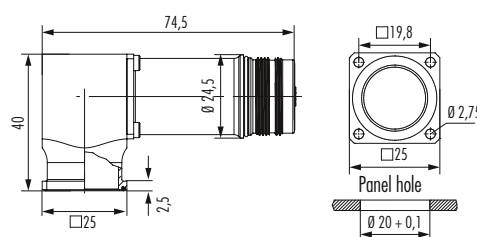

Type

Part Number

300° rotatable, locking screw at flange

4 holes 2.7 mm, Flange7.R43.108.000
Incl. 8 poles coupler, fully occupied

Optional: Gasket

Simple installation with M 2.5 screws



▶ 81

Panel Connector Rear Mount, dip solder insert

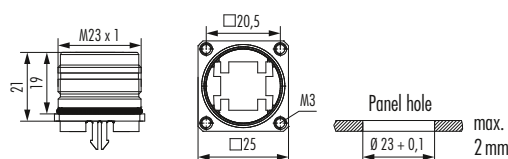

Type

Part Number

4x M 3 thread, Flange7.R45.008.000
Incl. 8 poles dip solder insert

4x M 3 thread, Flange7.R45.082.000
Incl. 8 + 2 poles dip solder insert





▶ 81

¹ upon request



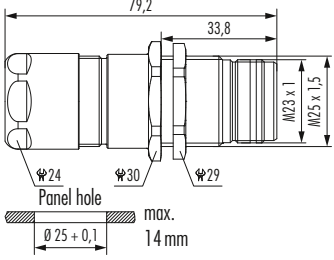



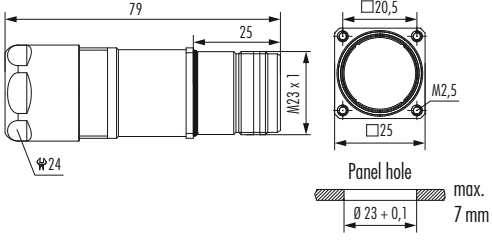

Housings

Single Hole Panel Connector with strain relief	Cable-Ø	Part Number
  <p>Technical drawing details: Total length: 79,2 mm Strain relief length: 33,8 mm Cable diameter: M23 x 1 Panel hole diameter: $\phi 25 + 0,1$ mm Max. panel hole depth: 14 mm Mounting hole diameters: $\phi 24$, $\phi 30$, $\phi 29$</p>	<p>Single Hole, Rear Mount, M 25 x 1,5 thread 3 – 7 mm (.12 - .28")7.R52.408.000 Incl. 8 poles coupler, fully occupied</p> <p>M 25 x 1,5 Locking Nut included</p>	<p>▶ 81</p>

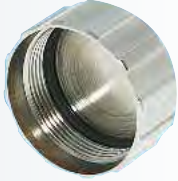
Panel Connector with strain relief	Cable-Ø	Part Number
  <p>Technical drawing details: Total length: 79 mm Strain relief length: 25 mm Cable diameter: M23 x 1 Panel hole diameter: $\phi 23 + 0,1$ mm Max. panel hole depth: 7 mm Mounting hole diameter: $\phi 24$ Flange dimensions: 20,5 mm x 25 mm Flange thread: M2,5</p>	<p>4x M 2,5 thread, Flange, Rear Mount 3 – 7 mm (.12 - .28")7.R47.408.000 Incl. 8 poles coupler, fully occupied</p>	<p>▶ 81</p>



Accessories	Type	Part Number
	Plastic protective cap for connectors with male thread7.000.900.101 with female thread7.000.900.102	
	Brass protective cap for connectors with female thread7.010.900.183	
	Brass protective cap for connectors with male thread7.010.900.102	
	Brass protective cap with chain for connectors with female thread Length 70 mm7.010.950.783 Length 100 mm7.010.951.083	
	Brass protective cap with chain for connectors with male thread Length 70 mm7.010.950.702 Length 100 mm7.010.951.002	
	Adaptor flange for Straight Connectors7.010.900.128	
	Conduit adaptor Poleon DN 127.010.900.205 Poleon DN 147.010.900.207 Poleon DN 177.010.900.209	



Accessories

Accessories	Type	Part Number
	Suitable patch cable	on request
	Field attachable RJ45 connector	
	8-pole	A7RJ-081M41
	8+2-pole	A7RJ-821M51
	Screw Tool, adjustable 0.5 – 1.7 Nm	7.010.900.190
	Tool Adapter for tightening or loosening knurled nuts for M23	7.010.900.192



Straight Connector, Female Thread

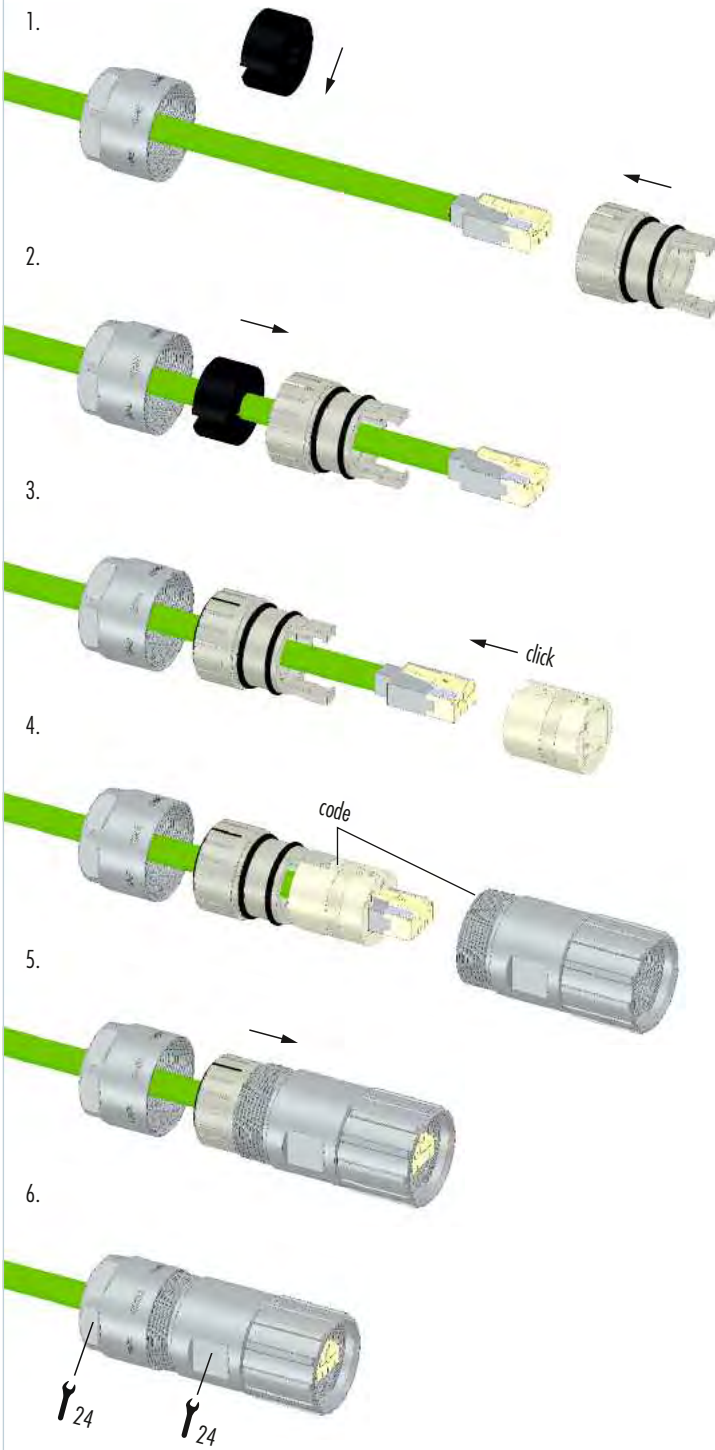



Assembly Instructions

Male Threaded Connector

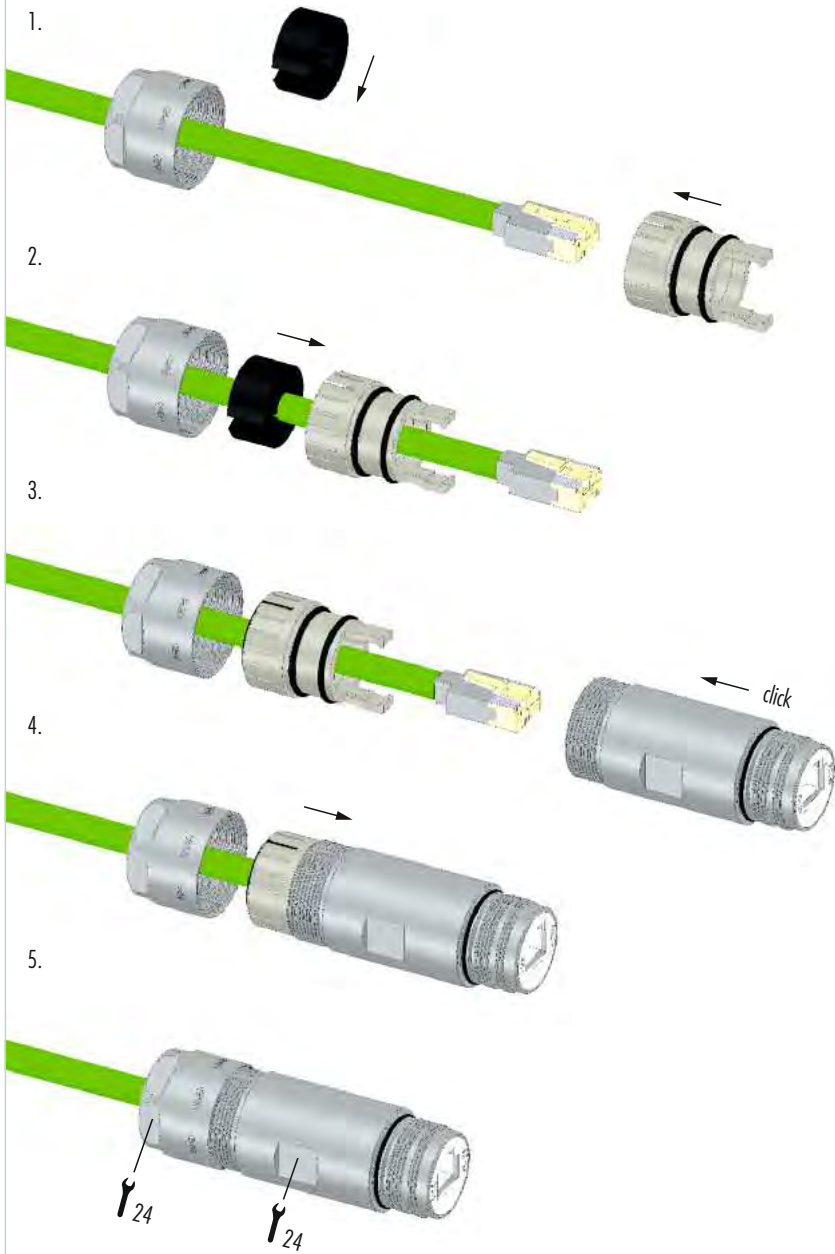

M 23 SIGNAL CONNECTORS

This reliable and universally applicable connector is widespread within industry. The connectors of HUMMEL AG can be customized freely. Moreover, they convince through their robustness and reliability. The range is modularly constructed and offers almost unlimited opportunities to the user.

- // Numerous housing types
- // Large variety
- // TWILOCK/TWILOCK-S quick release fastener



Product overview

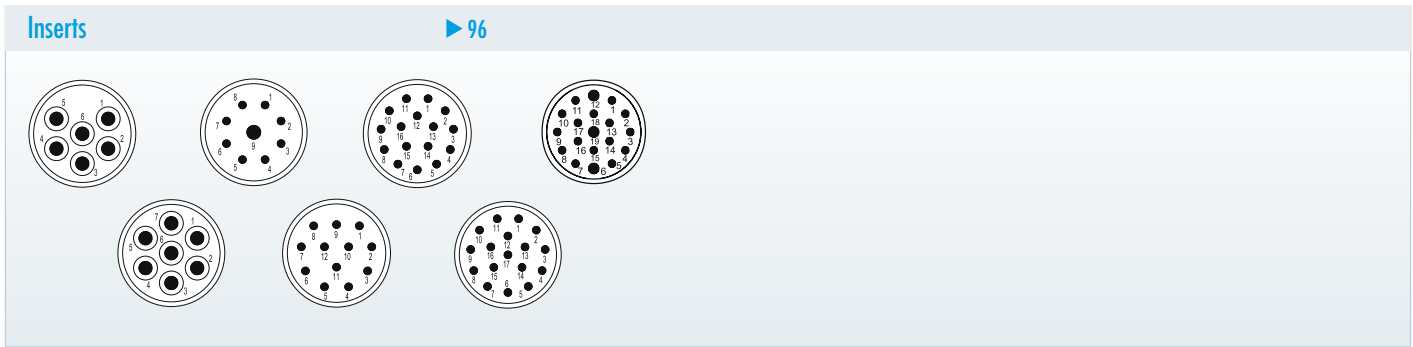

Mechanical Data	Materials and Technical Data
Housing	Copper-Zinc alloy Die Cast
Housing surface	Nickel plated other surface upon request
Inserts (for contacts)	Thermoplastic Polyamid PA 6 (Nylon 6/6), PBT Fire protection class V-0
Contacts	Brass Alloy
Contact surface at point of contact	Nickel and gold plated (0,25 µm)
Minimum mating cycles	> 1000*
Seals / O-Rings	Buna-N standard optional Viton® (FPM / FKM) (Viton is a registered trademark of DuPont)
Temperature range	-40 °C – 125 °C (-40 °F – 257 °F)
Type of contacts	Crimp, solder, dip-solder (PCB)
Protection	IP 67 / IP 69K per EN 60 529 (connected), NEMA 4x
Cable diameter range	3 – 17 mm (.12 – .67")

* HUMMEL to HUMMEL connector

Electrical Data	6	7	9 (8+1)	12	16	17	19 (16+3)
Number of positions	6	7	9 (8+1)	12	16	17	19 (16+3)
Number of contacts	6	7	8 1	12	16	17	16 3
Contact-Ø [mm]	2	2	1 2	1	1	1	1 1,5
Nominal current ¹⁾ [A]	20	20	8 20	8	8	8	8 10
Nominal voltage ²⁾ [V~] Degree of Protection 3 ³⁾	300	300	200	200	160	160	100
Test voltage (Breakdown voltage) ⁴⁾ [V~]	2500	2500	2500	2500	1500	1500	1500
Insulation resistance [Ω]	> 10 ¹⁰	> 10 ¹⁰	> 10 ¹⁰	> 10 ¹⁰	> 10 ⁶	> 10 ⁶	> 10 ⁶
Max. contact resistance [mΩ]	3	3	3	3	3	3	3

^{1), 2), 3), 4)} See Technical Information page 18



Housings

Straight Connector, Female Thread

Cable-Ø	Part Number
3 – 7 mm (.12 – .28")	7.106.400.000
7 – 12 mm (.28 – .47")	7.106.500.000
11 – 17 mm (.44 – .67")	7.106.600.000

Straight Connector, Female Thread TWILOCK / TWILOCK-S*

Cable-Ø	Part Number
3 – 7 mm (.12 – .28")	7.166.400.000
7 – 12 mm (.24 – .47")	7.166.500.000
11 – 17 mm (.43 – .67")	7.166.600.000

* intermateable with Speedtec

3 – 7 mm (.12 – .28")	7.166.400.00S
7 – 12 mm (.24 – .47")	7.166.500.00S
11 – 17 mm (.43 – .67")	7.166.600.00S

Straight Connector, Male Thread TWILOCK / TWILOCK-S*

Cable-Ø	Part Number
3 – 7 mm (.12 – .28")	7.206.400.000
7 – 12 mm (.28 – .47")	7.206.500.000
11 – 17 mm (.44 – .67")	7.206.600.000

* intermateable with Speedtec

3 – 7 mm (.12 – .28")	7.266.400.00S
7 – 12 mm (.24 – .47")	7.266.500.00S
11 – 17 mm (.43 – .67")	7.266.600.00S

Panel Connector, Male Thread, with Strain Relief

Cable-Ø	Part Number
4 threads M 3, rear mounting	
3 – 7 mm (.12 – .28")	7.476.400.000
7 – 12 mm (.28 – .47")	7.476.500.000
11 – 17 mm (.44 – .67")	7.476.600.000

Optional: Flat gasket

Housing without inserts and contacts

Panel Connector, Male Thread, with Strain Relief TWILOCK/TWILOCK-S*

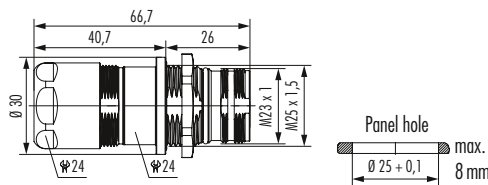

Cable-Ø

Part Number

Rear mounting, M 25 x 1,5 single hole mounted

3 – 7 mm (.12 – .28")	7.486.400.000
7 – 12 mm (.28 – .47")	7.486.500.000
11 – 17 mm (.44 – .67")	7.486.600.000
* intermateable with Speedtec	
3 – 7 mm (.12 – .28")	7.486.400.00S
7 – 12 mm (.28 – .47")	7.486.500.00S
11 – 17 mm (.44 – .67")	7.486.600.00S



Including jam nut M 25 x 1,5

Right Angle Connector, Female Thread with positioning

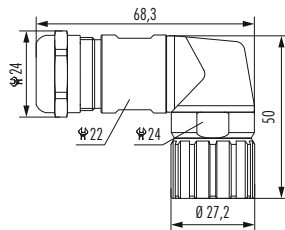

Cable-Ø

Part Number

3 – 7 mm (.12 – .28")	7.300.300.000
5 – 10 mm (.20 – .39")	7.300.400.000
7 – 12 mm (.28 – .47")	7.300.500.000
10 – 14 mm (.39 – .55")	7.300.600.000



Right Angle Connector, Female Thread, EMC with positioning

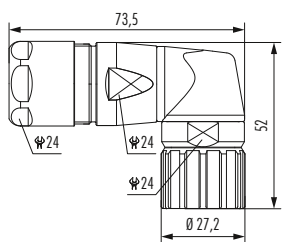

Cable-Ø

Part Number

7 – 12 mm (.28 – .47")	7.301.500.000
10 – 14 mm (.39 – .55")	7.301.600.000



Right Angle Connector, EMC, rotatable

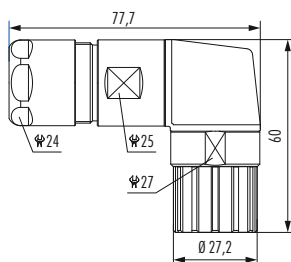

Cable-Ø

Part Number

7 – 12 mm (.28 – .47")	7.306.500.000
11 – 17 mm (.43 – .67")	7.306.600.000



Housing without inserts and contacts



Housings

Panel Connector, Male Thread, Front Mounting

Type	Part Number
4 holes Ø 3,2 mm (.13")	7.400.000.000 ¹
4 threads M 3	7.402.000.000 ¹
4 holes Ø 2,7 mm (.11")	7.404.000.000 ¹
4 threads M 2,5	7.406.000.000 ¹

▶ 96 |
 ▶ 104 |
 ▶ 113/114

Panel Connector, Male Thread, Front Mounting TWILOCK/TWILOCK-S*

Type	Part Number
With anti-vibration O-Ring	
4 holes Ø 3,2 mm (.13")	7.410.000.000
4 threads M 3	7.412.000.000 ¹
4 holes Ø 2,7 mm (.11")	7.414.000.000
4 threads M 2,5	7.416.000.000 ¹
* intermateable with Speedtec	
4 x Bholes 3,2 mm, Flange 25 x 25	7.410.000.00S
4 x Bohr. 3,2 mm, Flange 28 x 28	7.410.100.00S

▶ 96 |
 ▶ 104 |
 ▶ 113/114

Panel Connector, Female Thread, with knurled Nut

Type	Part Number
Without coding option	
4 holes Ø 3,2 mm (.13")	7.440.000.000
4 holes Ø 2,7 mm (.11")	7.444.000.000

▶ 96 |
 ▶ 104 |
 ▶ 113/114

Panel Connector, Female Thread, with knurled Nut, positionable

Type	Part Number
With coding option (8 x 45°)	
4 holes Ø 3,2 mm (.13")	7.448.000.000
4 holes Ø 2,7 mm (.11")	7.449.000.000

▶ 96 |
 ▶ 104 |
 ▶ 113/114

Housing without inserts and contacts

¹ no compatibility with TWILOCK



Panel Connector, Male Thread, Single Hole Mounted

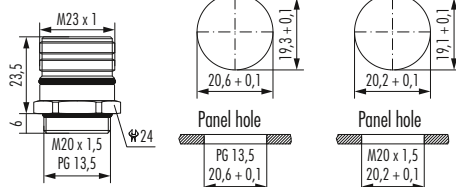

Type Part Number

Front mounting for male inserts	
Thread M 20 x 1,5	7.420.000.000 ¹
Thread PG 13,5	7.422.000.000 ¹

Optional: jam nut M 20 x 1,5 / PG 13,5

*** FOR MALE *
INSERTS ONLY**



Panel Connector, Male Thread, Single Hole Mounted

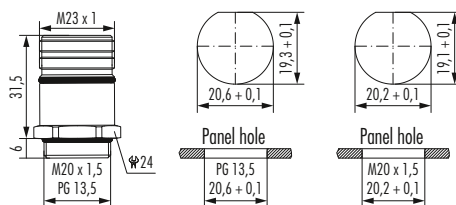

Type Part Number

Front mounting for female inserts	
Thread M 20 x 1,5	7.421.000.000 ¹
Thread PG 13,5	7.423.000.000 ¹

Optional: jam nut M 20 x 1,5 / PG 13,5

*** FOR FEMALE *
INSERTS ONLY**



Panel Connector, Male Thread, Single Hole Mounted

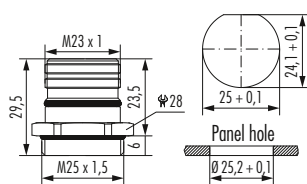

Type Part Number

For insert with pins / sockets	
Thread M 25 x 1,5	7.425.000.000 ¹

Optional: jam nut M 25 x 1,5



Housing without inserts and contacts

¹ no compatibility with TWILOCK



Housings

Right Angle Panel Connector, Male Thread

Type	Part Number
4 holes 2,7 mm (.11")	7.435.000.000

Easy fixation with M2,5 screws

Right Angle Panel Connector, Male Thread, rotatable

Type	Part Number
335° rotatable, hole mounted	
Thread M20 x 1,5	7.431.000.000

Right Angle Panel Connector, Male Thread, rotatable TWILOCK/TWILOCK-S*

Type	Part Number
330° rotatable, hole mounted	
4 x holes 3,2 mm (.13")	7.439.000.000
Flange 25 x 25 mm	
* intermateable with Speedtec	
4 x holes 3,2 mm (.13")	7.439.000.00S
Flange 25 x 25 mm	

Right Angle Panel Connector, Male Thread, rotatable TWILOCK/TWILOCK-S*

Type	Part Number
330° rotatable, hole mounted	
4 x holes 3,2 mm (.13")	7.439.100.000
Flange 28 x 28 mm	
* intermateable with Speedtec	
4 x holes 3,2 mm (.13")	7.439.100.00S
Flange 28 x 28 mm	

Housing without inserts and contacts

Panel Connector, Male Thread, Rear Mounting

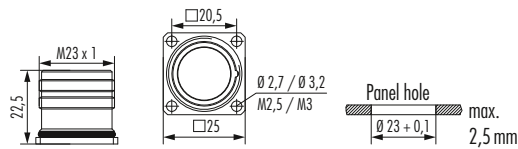

Type	Part Number
4 holes \varnothing 3,2 mm (.13")	7.450.000.000 ¹
4 threads M 3	7.452.000.000 ¹
4 holes \varnothing 2,7 mm (.11")	7.454.000.000 ¹
4 threads M 2,5	7.456.000.000 ¹



Panel Connector, Male Thread, Rear Mounting TWILOCK/TWILOCK-S*

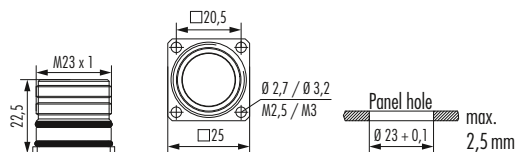

Type	Part Number
With anti-vibration O-Ring	
4 holes \varnothing 3,2 mm (.13")	7.460.000.000
4 threads M 3	7.462.000.000
4 holes \varnothing 2,7 mm (.11")	7.464.000.000
4 threads M 2,5	7.466.000.000
* intermateable with Speedtec	
4 x threads M 3	7.462.000.00S



Panel Connector, Male Thread, Single Hole Mounted TWILOCK/TWILOCK-S*

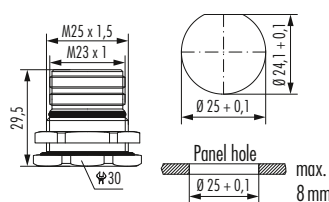
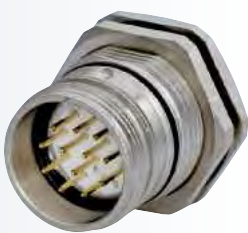

Type	Part Number
Rear mounting	
Thread M 25 x 1,5	7.458.000.000 ¹
* intermateable with Speedtec	
Thread M 25 x 1,5	7.458.000.00S
Including jam nut M 25 x 1,5	



Panel Connector, Female Thread, Rear Mounting

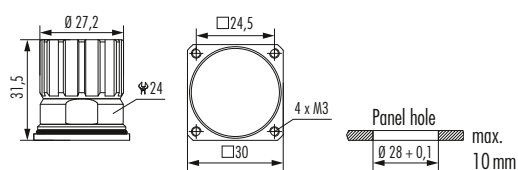

Type	Part Number
With knurled nut, rear mounting	
4 threads M 3	7.459.000.000











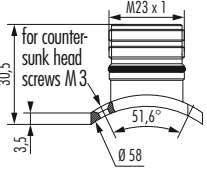
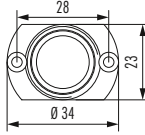

Housing without inserts and contacts



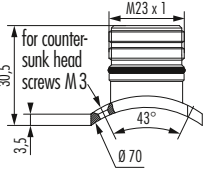
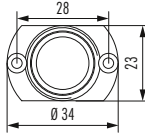

¹ no compatibility with TWILOCK

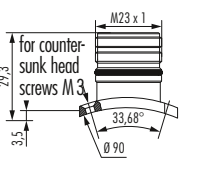
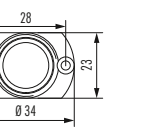

Housings

Panel Connector with Radius Flange		Type	Part Number
  		With anti-vibration O-Ring and flat body gasket Ø 58 mm (2.28")7.490.000.000 ¹	
		   	▶ 96 ▶ 104 ▶ 113/114

Panel Connector with Radius Flange		Type	Part Number
  		With anti-vibration O-Ring and flat body gasket Ø 70 mm (2.76")7.491.000.000 ¹	
		   	▶ 96 ▶ 104 ▶ 113/114

Panel Connector with Radius Flange		Type	Part Number
  		With anti-vibration O-Ring and flat body gasket Ø 90 mm (3.54")7.492.000.000 ¹	
		   	▶ 96 ▶ 104 ▶ 113/114



Housing without inserts and contacts

¹ no compatibility with TWILOCK



Signal Distribution	Type	Part Number
		<p>▶ 96</p> <p>▶ 104</p>

Signal Distribution	Type	Part Number
		<p>▶ 96</p> <p>▶ 104</p>

Signal Distribution	Type	Part Number
<p>In case of so called Flying Connections it is often required to distribute, cross or combine signals. Depending on the requirements of the application, the connections can be supplied either as male or female connector, or they can be configured with strain relief fittings. There are many possible combinations, including the internal wiring, independent of their style, as T-, Y-, H-, or other special configurations.</p>		

Bus End Connector	Type	Part Number
	<p>Closed type.....7.105.000.000</p> <p>Used to cap an open male connector in bus-systems</p>	



Housing without inserts and contacts

¹ no compatibility with TWILOCK



Inserts / Pinouts

Inserts 6-pole		Type	Part Number	Part Number
	Insert pin mating view (Part E)	Pinout clockwise	Pins	Sockets
		Insert with solder contacts.....	7.001.906.103	7.001.906.104
	Insert socket mating view (Part P)	Insert without contacts	7.003.906.101	7.003.906.102
		Insert with dip solder contacts		
		Length 3,5 mm	7.001.906.107	
		Insert with dip solder contacts		
		Length 10 mm	7.001.906.127	7.001.906.108
		Insert with dip solder contacts		
		Length 17 mm	7.001.906.137	7.001.906.118
<p>The correct dimension of a connector with dip solder contacts depends on the particular type of housing.</p> <p>Coding possibilities N, S, H, X, Y and Z (see page 101)</p>				



Inserts 7-pole		Type	Part Number	Part Number
	Insert pin mating view (Part E)	Pinout clockwise	Pins	Sockets
		Insert with solder contacts.....	7.001.907.103	7.001.907.104
	Insert socket mating view (Part P)	Insert without contacts	7.003.907.101	7.003.907.102
		Insert with dip solder contacts		
		Length 3,5 mm	7.001.907.107	
		Insert with dip solder contacts		
		Length 10 mm	7.001.907.127	7.001.907.108
		Insert with dip solder contacts		
		Length 17 mm	7.001.907.137	7.001.907.118
<p>The correct dimension of a connector with dip solder contacts depends on the particular type of housing.</p> <p>Coding possibilities N, S, H, X and Y (see page 101)</p>				





Inserts 9-pole (8 + 1)		Type	Part Number	Part Number
<p>Insert pin mating view (Part E)</p>	<p>Pinout clockwise</p> <p>Insert with solder contacts.....7.001.981.103</p> <p>Insert without contacts7.003.981.101</p>	<p>Pins</p>	<p>Sockets</p>	
			<p>Insert with dip solder contacts</p> <p>Length 3,5 mm7.001.981.107</p>	
<p>Insert socket mating view (Part P)</p>	<p>Insert with dip solder contacts</p> <p>Length 10 mm7.001.981.127</p>	<p>Insert with dip solder contacts</p> <p>Length 17 mm7.001.981.137</p>	<p>.....7.001.981.108</p> <p>.....7.001.981.118</p>	
			<p>The correct dimension of a connector with dip solder contacts depends on the particular type of housing.</p> <p>Coding possibilities N, S, H, X and Y (see page 101)</p>	
		▶ 102/103		

Inserts 9-pole (8 + 1)		Type	Part Number	Part Number
<p>Insert pin mating view (Part P)</p>	<p>Pinout counter-clockwise</p> <p>Insert with solder contacts.....7.002.981.103</p> <p>Insert without contacts7.004.981.101</p>	<p>Pins</p>	<p>Sockets</p>	
			<p>Insert with dip solder contacts</p> <p>Length 3,5 mm7.002.981.107</p>	
<p>Insert socket mating view (Part E)</p>	<p>Insert with dip solder contacts</p> <p>Length 10 mm7.002.981.127</p>	<p>Insert with dip solder contacts</p> <p>Length 17 mm7.002.981.137</p>	<p>.....7.002.981.108</p> <p>.....7.002.981.118</p>	
			<p>The correct dimension of a connector with dip solder contacts depends on the particular type of housing.</p> <p>Coding possibilities N, S, H, X and Y (see page 101)</p>	
		▶ 102/103		



Inserts / Pinouts

Inserts 12-pole		Type	Part Number	Part Number	
<p>Insert pin mating view (Part E)</p> <p>Insert socket mating view (Part P)</p>	Pinout clockwise	Pins	Sockets		
	Insert with solder contacts.....	7.001.912.103	7.001.912.104		
	Insert with solder contacts +PE (Pos.9).....	7.001.912.113	7.001.912.114		
	Insert without contacts	7.003.912.101	7.003.912.102		
	Insert without contacts +PE (Pos.9)	7.003.912.111	7.003.912.112		
	Insert with dip solder contacts Length 3,5 mm	7.001.912.107			
	Insert with dip solder contacts Length 10 mm	7.001.912.127	7.001.912.108		
	Insert with dip solder contacts Length 17 mm	7.001.912.137	7.001.912.118		
	The correct dimension of a connector with dip solder contacts depends on the particular type of housing.				
	Coding possibilities N, S, H, X, Y and Z (see page 101)				
	▶ 102/103				

Inserts 12-pole		Type	Part Number	Part Number	
<p>Insert pin mating view (Part P)</p> <p>Insert socket mating view (Part E)</p>	Pinout counter-clockwise	Pins	Sockets		
	Insert with solder contacts.....	7.002.912.103	7.002.912.104		
	Insert with solder contacts +PE (Pos.9).....	7.002.912.113	7.002.912.114		
	Insert without contacts	7.004.912.101	7.004.912.102		
	Insert without contacts +PE (Pos.9)	7.004.912.111	7.004.912.112		
	Insert with dip solder contacts Length 3,5 mm	7.002.912.107			
	Insert with dip solder contacts Length 10 mm	7.002.912.127	7.002.912.108		
	Insert with dip solder contacts Length 17 mm	7.002.912.137	7.002.912.118		
	The correct dimension of a connector with dip solder contacts depends on the particular type of housing.				
	Coding possibilities N, S, H, X, Y and Z (see page 101)				
	▶ 102/103				



Inserts 16-pole

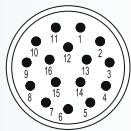

Insert pin mating view (Part E)

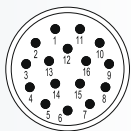

Insert socket mating view (Part P)

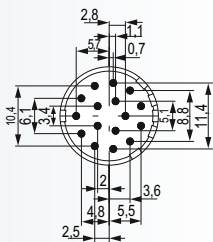

Type	Part Number	Part Number
Pinout clockwise	Pins	Sockets
Insert with solder contacts.....	7.001.916.103	7.001.916.104
Insert without contacts	7.003.916.101	7.003.916.102
Insert with dip solder contacts		
Length 3,5 mm	7.001.916.107	
Insert with dip solder contacts		
Length 10 mm	7.001.916.127	7.001.916.108
Insert with dip solder contacts		
Length 17 mm	7.001.916.137	7.001.916.118

The correct dimension of a connector with dip solder contacts depends on the particular type of housing.

Coding possibilities N, S, H, X, Y and Z (see page 101)



Inserts 17-pole

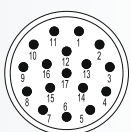

Insert pin mating view (Part E)

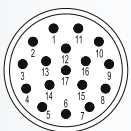

Insert socket mating view (Part P)

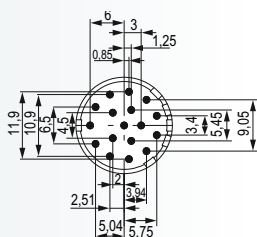

Type	Part Number	Part Number
Pinout clockwise	Pins	Sockets
Insert with solder contacts.....	7.001.917.103	7.001.917.104
Insert without contacts	7.003.917.101	7.003.917.102
Insert with dip solder contacts		
Length 3,5 mm	7.001.917.107	
Insert with dip solder contacts		
Length 10 mm	7.001.917.127	7.001.917.108
Insert with dip solder contacts		
Length 17 mm	7.001.917.137	7.001.917.118

The correct dimension of a connector with dip solder contacts depends on the particular type of housing.

Coding possibilities N, S, H, X, Y and Z (see page 101)



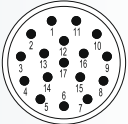
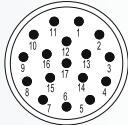

Inserts / Pinouts

Inserts 17-pole	Type	Part Number	Part Number
 <p>Insert pin mating view (Part P)</p>	Pinout counter-clockwise	Pins	Sockets
	Insert with solder contacts.....	7.002.917.103	7.002.917.104
 <p>Insert socket mating view (Part E)</p>	Insert without contacts	7.004.917.101	7.004.917.102
	Insert with dip solder contacts Length 3,5 mm	7.002.917.107	
	Insert with dip solder contacts Length 10 mm	7.002.917.127	7.002.917.108
	Insert with dip solder contacts Length 17 mm	7.002.917.137	7.002.917.118
<p>The correct dimension of a connector with dip solder contacts depends on the particular type of housing.</p> <p>Coding possibilities N, S, H, X, Y and Z (see page 101)</p>			

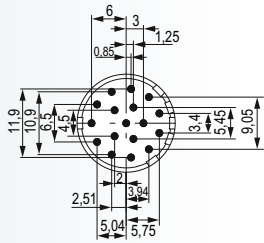

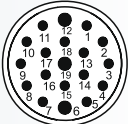
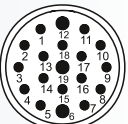
Inserts 19-pole	Type	Part Number	Part Number
 <p>Insert pin mating view (Part E)</p>	Pinout clockwise	Pins	Sockets
	Insert with solder contacts.....	7.001.919.103	7.001.919.104
 <p>Insert socket mating view (Part P)</p>	Insert with solder contacts +PE (Pos.12).....	7.001.919.113	7.001.919.114
	Insert with solder contacts + PE (Pos.12) 1,5 mm elongated ...	7.001.919.123	
	Insert without contacts	7.003.919.101	7.003.919.102
	Insert without contacts +PE (Pos.12)	7.003.919.111	7.003.919.112
	Insert with dip solder contacts Length 3,5 mm	7.001.919.107	
	Insert with dip solder contacts Length 10 mm	7.001.919.127	7.001.919.108
	Insert with dip solder contacts Length 17 mm	7.001.919.137	7.001.919.118
<p>The correct dimension of a connector with dip solder contacts depends on the particular type of housing.</p> <p>Coding possibilities N, S, H, X and Y (see page 101)</p>			

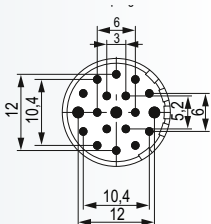



Contact Arrangement	Number of Poles	Required Contacts
	6	6 x 2 mm
	7	7 x 2 mm
	9 (8+1)	8 x 1 mm 1 x 2 mm
	12	12 x 1 mm
	16	16 x 1 mm
	17	17 x 1 mm
	19	16 x 1 mm 3 x 1,5 mm
	10	Housings and contacts 10-pole, see chapter „M 23 Power, M 23 Hybrid“, page 130 – 136

For the M23 crimp insert with 1 mm contacts can be used stamped crimp contact.



▶ 102/103

Coding	Number of Poles	Coding Possibilities
	6-pole	N, S, H, X, Y and Z
	7-pole	N, S, H, X and Y
	9-pole	N, S, H, X and Y
	12-pole	N, S, H, X, Y and Z
	16-pole	N, S, H, X, Y and Z
	17-pole	N, S, H, X, Y and Z
	19-pole	N, S, H, X and Y

As standard, coding groove N is opened. To use other codings, please remove the coding barrier.





Contacts

Contacts	Type	Crimp Range	Part Number
	Crimp pin 1 mm, machined.....	0,08 – 0,56 mm ² (AWG 28 – 20)	7.010.901.031
	Crimp pin 1 mm, machined	0,14 – 1 mm ² (AWG 26 – 17)	7.010.901.001
	Crimp pin 1 mm, machined.....	0,75 – 1,5 mm ² (AWG 17 – 16)	7.010.901.021
	Crimp socket 1 mm, machined	0,08 – 0,56 mm ² (AWG 28 – 20)	7.010.901.012
	Crimp socket 1 mm, machined	0,34 – 1 mm ² (AWG 22 – 17)	7.010.901.002
	Crimp socket 1 mm, machined	0,75 – 1,5 mm ² (AWG 17 – 16)	7.010.901.022
	Crimp pin 1 mm, stamped	0,14 – 0,56 mm ² (AWG 26 – 20)	upon request
	Crimp socket 1 mm, stamped	0,14 – 0,56 mm ² (AWG 26 – 20)	upon request
	Crimp pin 1,5 mm, machined	0,14 – 1 mm ² (AWG 26 – 17)	7.010.901.501
	Crimp socket 1,5 mm, machined	0,14 – 0,56 mm ² (AWG 26 – 20)	7.010.901.512
	Crimp socket 1,5 mm, machined	0,56 – 1 mm ² (AWG 20 – 17)	7.010.901.502



Contacts

Contacts	Type	Crimp Range	Part Number
	Crimp pin 2 mm, machined.....	0,75 – 2,5 mm ² (AWG 18 – 14)	7.010.902.001
	Crimp socket 2 mm, machined.....	0,75 – 2,5 mm ² (AWG 18 – 14)	7.010.902.002



Accessories

Accessories	Type	Part Number
	Plastic protective cap for connectors with male thread with female thread	7.000.900.101 7.000.900.102
	Brass protective cap for connectors with female thread	7.010.900.103 ¹
	Brass protective cap for connectors with male thread	7.010.900.102
	Brass protective cap with chain for connectors with female thread Length 70 mm Length 100 mm	7.010.9S0.703 ¹ 7.010.9S1.003 ¹
	Brass protective cap with chain for connectors with male thread Length 70 mm Length 100 mm	7.010.9S0.702 7.010.9S1.002
	Assembly tool	7.010.900.101
	Crimp tool for manual crimping of machined crimp contacts for signal connectors	7.000.900.904



¹ no compatibility with TWILOCK

Accessories	Type	Part Number
	Adaptor flange for Straight Connectors.....	7.010.900.128 ¹
	Conduit adaptor Poleon DN 12 Poleon DN 14 Poleon DN 17	7.010.900.205 7.010.900.207 7.010.900.209
	Positioner for Crimp Tool DMC M22520	7.000.900.DMC
	Locator for Crimp Tool DMC M22520 with positioner For HUMMEL Contact: 7.010.901.001, 7.010.901.501, 7.010.902.001, 7.010.901.031	7.000.9DM.C03
	Locator for Crimp Tool DMC M22520 with positioner For HUMMEL Contact: 7.010.901.012, 7.010.901.002, 7.010.901.512, 7.010.901.502, 7.010.902.002	7.000.9DM.C04
	Screw Tool, adjustable 0.5 – 1.7 Nm	7.010.900.190
	Tool Adapter for tightening or loosening knurled nuts for M 23	7.010.900.192
	Crimping tool pneumatic crimping tool.....on request Crimping machine crimping machine to process turned contacts.....on request	on request on request

¹ no compatibility with TWILOCK



Crimp Tool Setting for HUMMEL Crimp Contacts (Crimp Tool 7.000.900.904)

Part Number	Crimp Contact	Cross Section (mm ²)	AWG	Crimp Tool Setting mm	Locator Setting
7.010.901.001	Crimp pin 1 mm	0,14	AWG 26	0,70	1
		0,25	AWG 24	0,76	
		0,34	AWG 22	0,82	
		0,50	AWG 20	0,90	
		0,75	AWG 18	1,00	
		1,00	AWG 17	1,10	
7.010.901.012	Crimp socket 1 mm (0,08 – 0,56 mm ²)	0,08	AWG 28	0,75	2
		0,14	AWG 26	0,78	
		0,25	AWG 24	0,82	
		0,34	AWG 22	0,86	
		0,56	AWG 20	0,90	
7.010.901.002	Crimp socket 1 mm (0,34 – 1 mm ²)	0,34	AWG 22	0,77	2
		0,56	AWG 20	0,82	
		0,75	AWG 18	0,88	
		1,00	AWG 17	0,95	
7.010.901.501	Crimp pin 1,5 mm	0,14	AWG 26	0,65	3
		0,25	AWG 24	0,68	
		0,34	AWG 22	0,72	
		0,56	AWG 20	0,81	
		0,75	AWG 18	0,95	
		1,00	AWG 17	1,07	
7.010.901.512	Crimp socket 1,5 mm (0,14 – 0,56 mm ²)	0,14	AWG 26	0,70	2
		0,25	AWG 24	0,73	
		0,34	AWG 22	0,77	
		0,56	AWG 20	0,85	
7.010.901.502	Crimp socket 1,5 mm (0,34 – 1 mm ²)	0,34	AWG 22	0,88	2
		0,56	AWG 20	0,95	
		0,75	AWG 18	1,05	
		1,0	AWG 17	1,13	
7.010.902.001	Crimp pin 2 mm	0,75	AWG 18	1,25	4
		1,0	AWG 17	1,35	
		1,5	AWG 16	1,45	
		2,5	AWG 14	1,60	
7.010.902.002	Crimp socket 2 mm	0,75	AWG 18	1,25	5
		1,0	AWG 17	1,35	
		1,5	AWG 16	1,45	
		2,5	AWG 14	1,60	



These values are only guidelines and actual conductor cross sections depend on manufacturer tolerances.



Crimp Tool Setting for HUMMEL Crimp Contacts (Crimp Tool 7.000.900.904)

Part Number	Crimp Contact	Cross Section (mm ²)	AWG	Crimp Tool Setting mm	Locator Setting
7.010.901.031	Crimp pin 1 mm	0,08	28	0,72	1
		0,14	26	0,78	
		0,25	24	0,82	
		0,34	22	0,86	
		0,56	20	0,90	
7.010.901.021	Crimp pin 1 mm	0,75	18	0,80	1
		1,00	17	0,86	
		1,50	16	0,95	
7.010.901.022	Crimp socket 1 mm	0,75	18	0,80	2
		1,00	17	0,86	
		1,50	16	0,95	



These values are only guidelines and actual conductor cross sections depend on manufacturer tolerances.



Crimp Tool for Signal Connectors M 23 / M 16

Crimp Tool	Type	Part Number
	Crimp Tool7.000.900.904 / 7.000.900.907	
	Application The four indent crimp tool 7.000.900.904 / 7.000.900.907 has been developed for optimal crimping of machined contacts with diameters from 0.08 to 2.5 mm ² (28 through 14 AWG).	
	How to Crimp The reference table (S. 71 / 106) indicates the correct locator position to be selected and the crimp depth to be adjusted for the contact to be crimped. The contact is then inserted through the access hole of the tool on the opposite side of the locator. The contact is held in place by closing the handles to the first lock-in position thus preventing the contact from falling out of the tool and facilitating insertion of the wire into the contact. The precision ratchet assures consistently accurate crimping every time by forcing the tool to be closed all the way completing the crimping cycle before the tool can be opened again.	
	Exchange of the Locator The locator can be exchanged by removing the socket head cap screw with a socket wrench. It can then be disassembled from the hex head screw by turning it counter-clockwise.	



Crimp Tool



Adjustment of Crimp Depth

Crimp depth can be adjusted as follows:

Turn the adjusting screw clockwise for reducing the crimp depth and counter-clockwise for increasing the crimp depth.

Adjustment Increments:

- // 1 space on the adjusting screw $\hat{=}$ adjustment 1/100 mm
- // 1 full rotation of adjusting screw $\hat{=}$ adjustment by 0.2 mm (indication on the screw as well as on the rough scale)
- // 5 rotations of the adjusting screw $\hat{=}$ adjustment by 1 mm (indication on the scale)

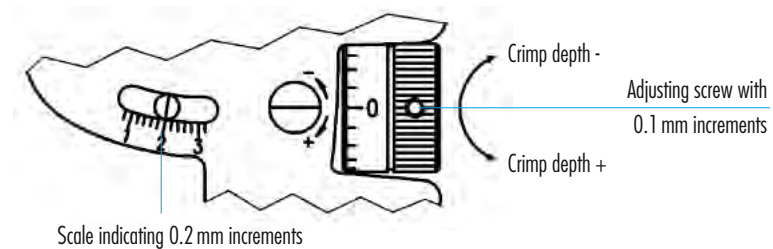

Control of Crimp Depth

Crimp tool adjustment is done at the factory, but with frequent use, periodic calibration is recommended to insure accuracy. This is easily accomplished with a 1.0 mm \varnothing wire gauge as follows. A crimp depth of 1.0 mm is set by means of the adjusting screw (scale mark at „1“, screw mark at „0“ as shown in the fig. above) and the tool in the closed position.

After insertion of the gauge, there must be just enough space for moving the gauge inside the entry hole. If the opening is too small or too large to exactly match the gauge, the deviation (+/-) can be checked by the precision setting of the screw. Please contact the factory in case the deviation exceeds the tolerances specified by the contract manufacturer.

Maintenance and Repair

Keep the tool clean and properly stored when not in service. All pivot points need to be oiled regularly and the spring clips securing the bolts have to always be in place. For repair please send the tool back to the factory.



Assembly Instructions

Straight Connector, Male / Female Thread

1. max. 25 mm
2. 4 mm
3. crimp
4. click
5. click
6. click
7. code
8. 24 24

♀

♂



Right Angle Connectors, EMC

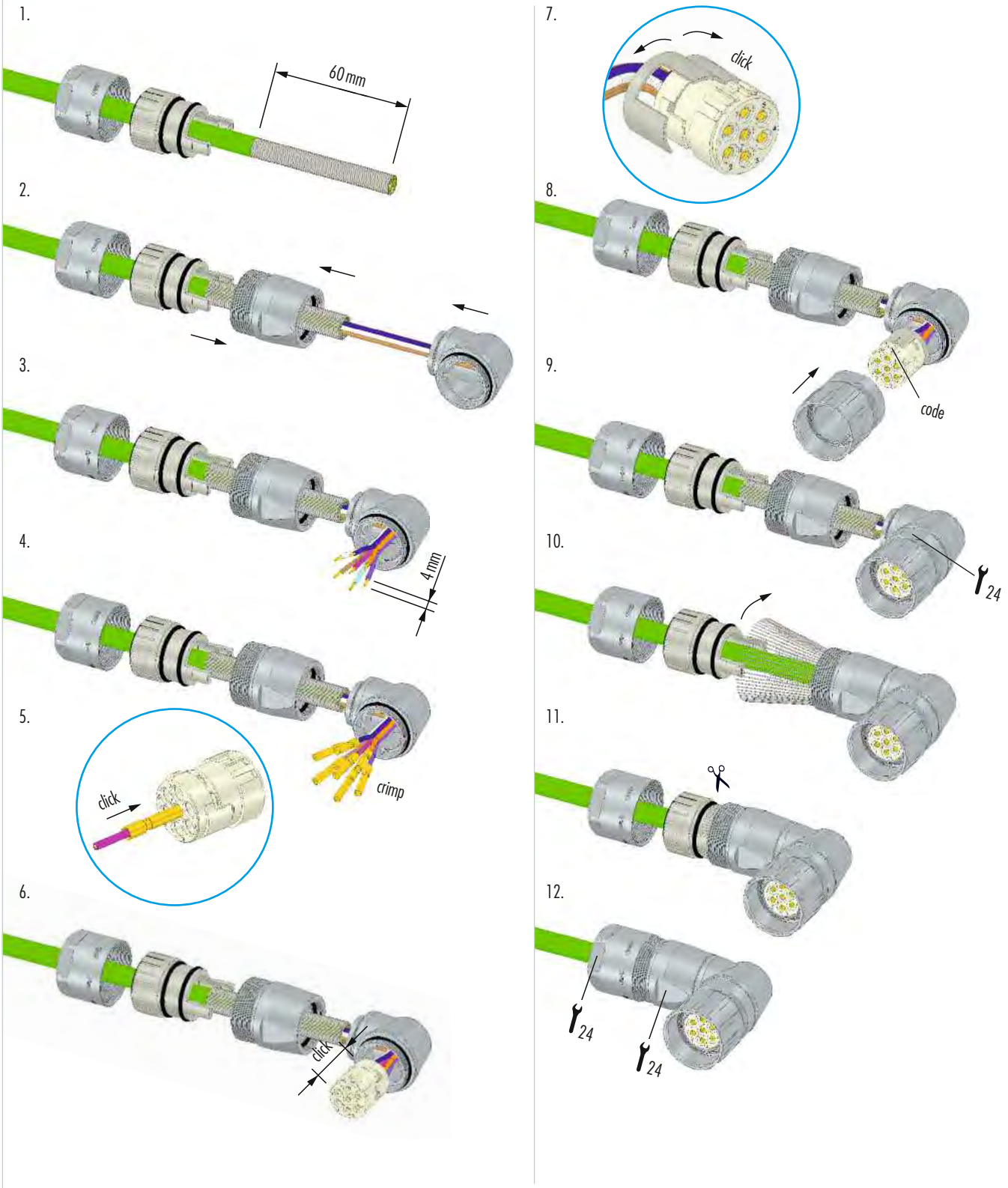



Assembly Instructions

Right Angle Connector, rotatable, EMC

1. Strip the green outer jacket of the cable by 65 mm.
2. Strip the braided shield by 10 mm.
3. Strip the four signal wires (red, blue, yellow, green) by 4 mm.
4. Strip the remaining green jacket by 4 mm.
5. Insert the signal wires into the connector housing. A "click" sound indicates they are seated. The wires are crimped.
6. Push the connector housing onto the cable jacket. A "click" sound indicates it is seated.
7. Rotate the connector housing to the desired angle. A "click" sound indicates it is locked.
8. Insert the second cable into the connector housing. A "click" sound indicates it is seated.
9. Push the second connector housing onto the second cable jacket. A "click" sound indicates it is seated. The "code" is visible.
10. Tighten the connector housing with a 27 mm wrench.
11. Trim the excess braided shield with scissors.
12. Tighten the outer jacket with a 24 mm wrench and the second connector housing with a 25 mm wrench.



Panel Connectors, Male Inserts

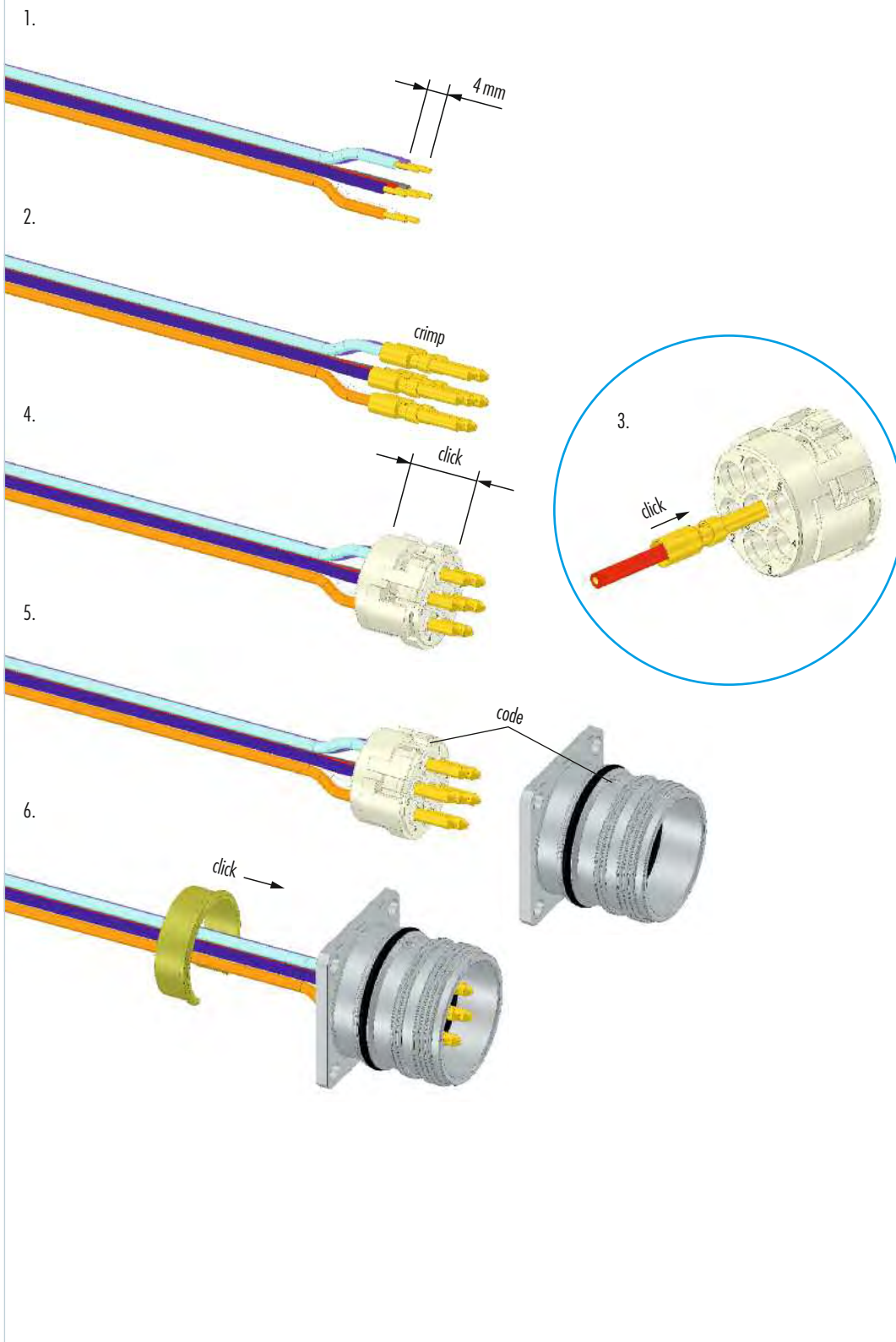

M 12
M 16
M 23 PoE
M 23 RJ 45
M 23 Signal
M 27 Signal
M 23 Power
M 40 Power
INOX
Moulded Cordsets
Customized



Assembly Instructions

Panel Connectors, Female Inserts

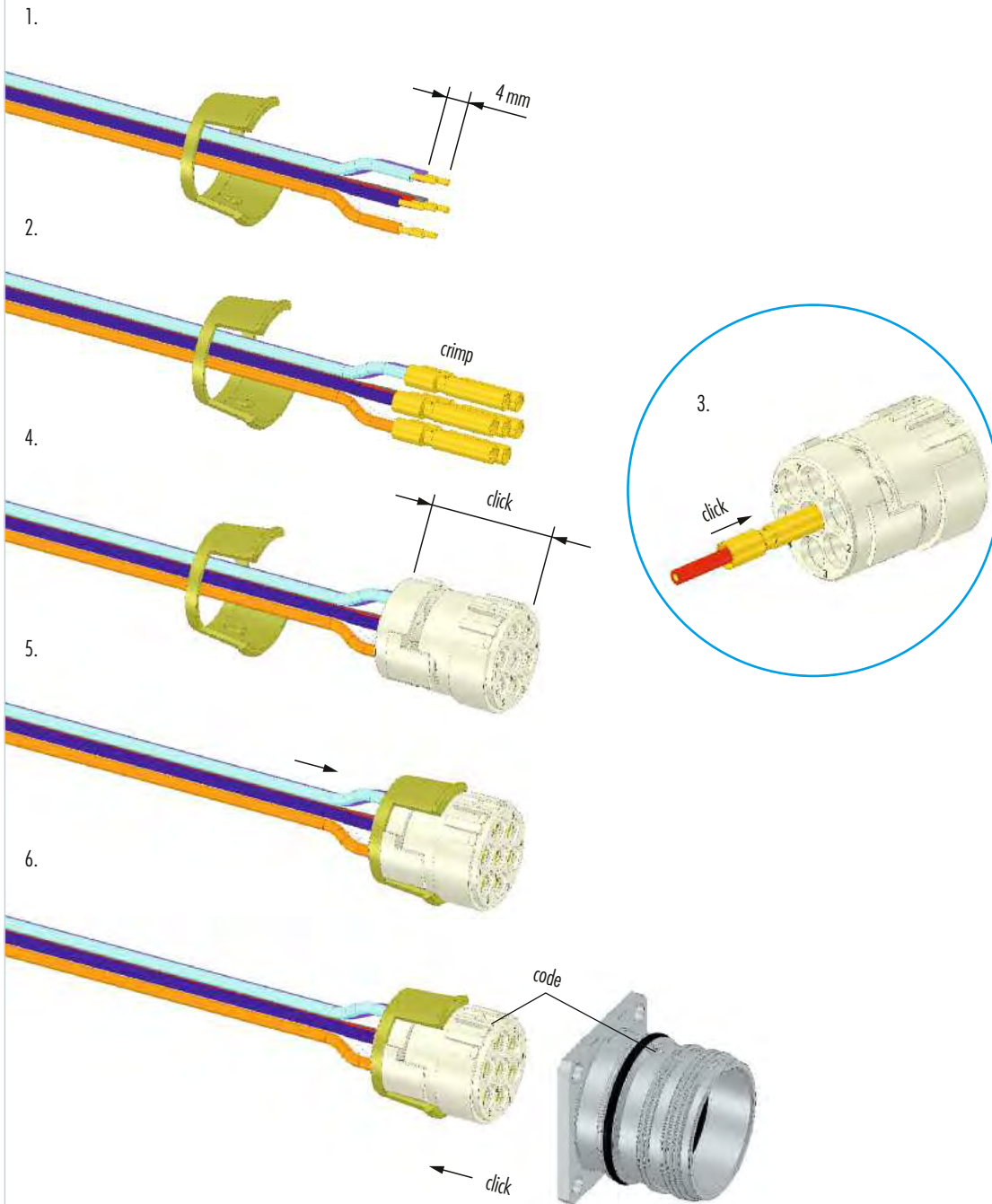



Right Angle Panel Connector

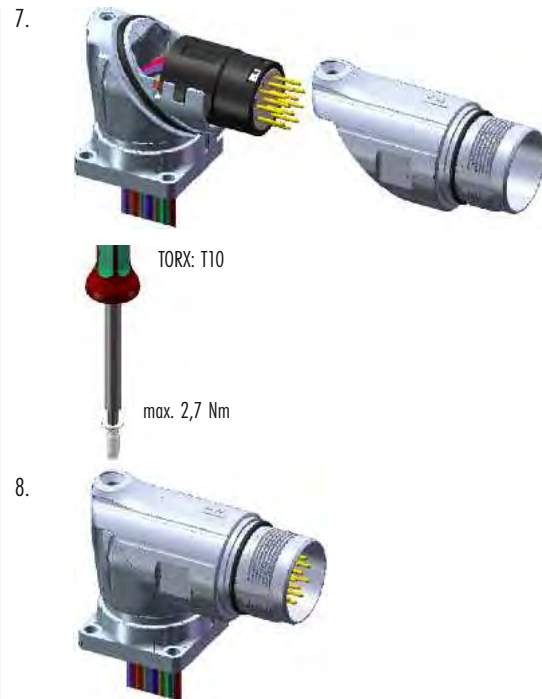
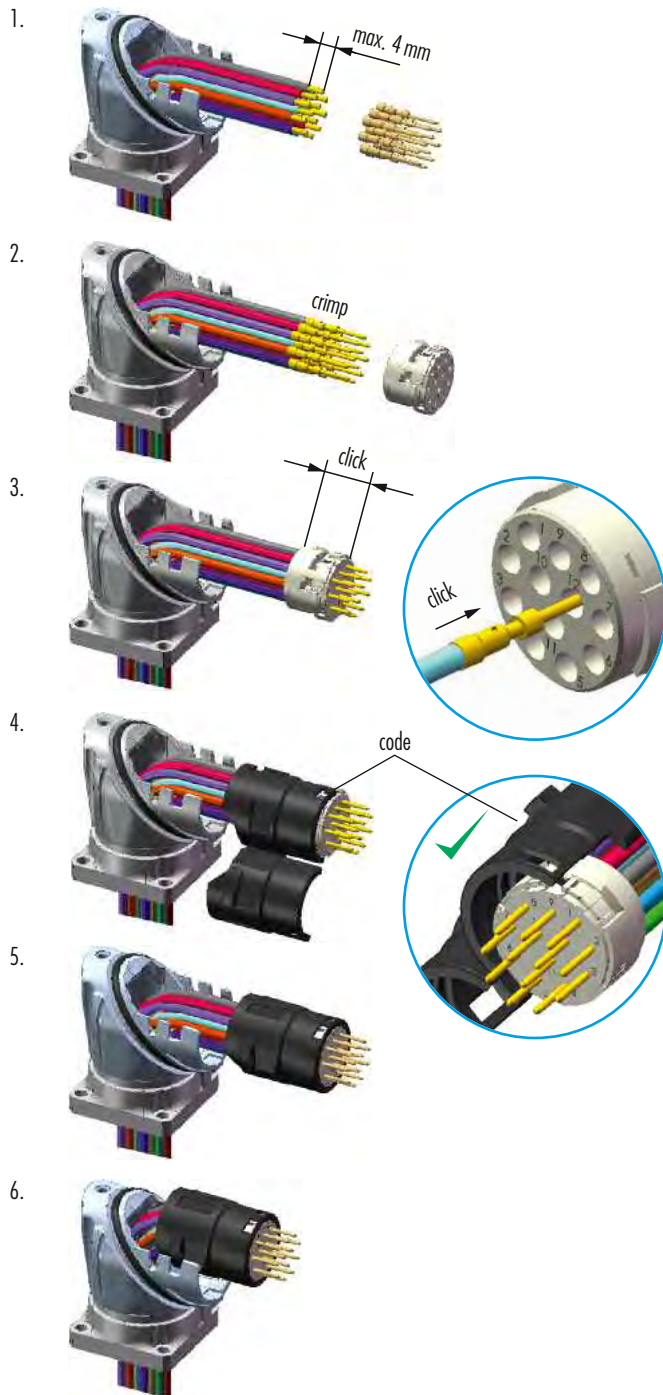

Bei Verwendung von TWILOCK-S oder Speedtec Stecker bitte O-Ring demontieren.





Crimping, Assembly and Disassembly of Contacts

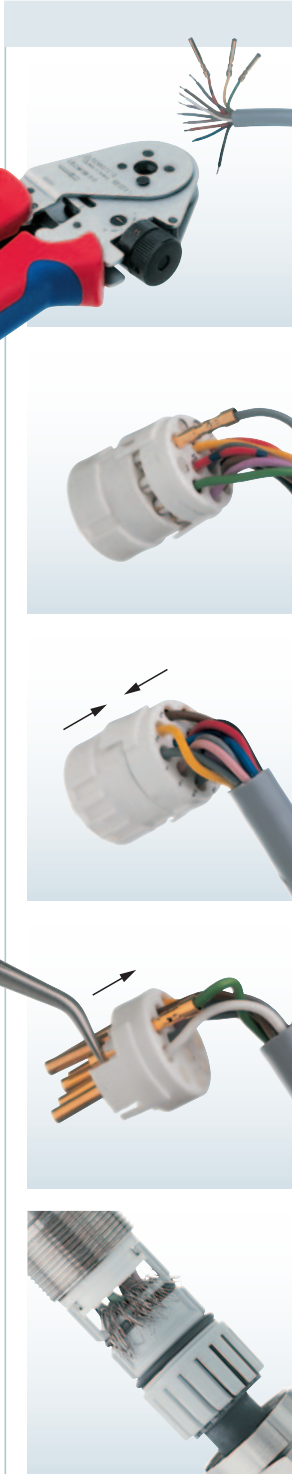

Crimping

- // Remove conductor insulation 4 mm (.16") max.
- // Select appropriate Crimp tool setting
- // Insert Crimp contact into the positioner of the tool
- // Insert stripped end of conductor into the crimp opening of the contact
- // Squeeze handles of crimp tool together

Assembly

- // Open crimping jaws and remove contact
- // Pry open upper and lower insert approx. 3 mm (1/8") apart as shown
- // Insert the contact and conductor assembly into the desired location
- // Press upper and lower insert parts together

Interlock Contacts

- // press the upper and lower part of the insulator together

Disassembly

No special tools are needed to remove the crimp contacts from the insert.

- // Remove upper part of insert
- // With a pair of needle nose pliers, wiggle the contact and push it back through the lower part of insert
- // Insert contacts into new location and push until it snaps in position
- // Align the nose and groove of the upper and lower part of insert and press together

Shielding

- // Assemble strain relief insert with insert
- // Fold stranding of the shield back over the first O-Ring of the strain relief insert
- // Cut back the overextending braid



The stranding of the shield is not allowed to touch the second O-Ring. Otherwise the assembly may not be proof.

M 27 SIGNAL CONNECTORS

M 27 signal connectors of HUMMEL AG are available in 26- or 28 pole type. It can be seen at the high protection class (IP 67) and the large temperature range (up to + 125 °C) of these connectors.

- // M 27 connectors, male and female thread
- // Panel connectors
- // Large selection of accessories



Product overview

Housings ▶ 120

Inserts ▶ 121

Accessories ▶ 123

Mechanical Data	Materials and Technical Data
Housing	Copper-Zinc alloy Die Cast
Housing surface	Nickel plated other surface upon request
Inserts (for contacts)	Thermoplastic Polyamid PA 6 (Nylon 6/6), PBT Fire protection class V-0
Contacts	Brass Alloy
Contact surface at point of contact	Nickel and gold plated (0,25 µm)
Minimum mating cycles	50
Seals / O-Rings	Buna-N standard optional Viton® (FPM / FKM) (Viton is a registered trademark of DuPont)
Temperature range	-40 °C – 125 °C (-40 °F – 257 °F)
Type of contacts	Crimp, solder, dip-solder (PCB)
Protection	IP 67 per EN 60 529 (connected), NEMA 4x
Cable diameter range	7 – 17 mm (.28 – .67")

Electrical Data		
Number of positions	26	28
Number of contacts	26	28
Contact-Ø [mm]	1	1
Nominal current ¹⁾ [A]	8	8
Nominal voltage ²⁾ [V~]	150	150
Test voltage (Breakdown voltage) ³⁾ [V~]	1500	1500
Insulation resistance [Ω]	> 10 ¹²	> 10 ¹²
Max. contact resistance [mΩ]	3	3
Degree of Protection ⁴⁾	3	3

^{1), 2), 3), 4)} See Technical Information page 18



Housings

Straight Connector, Female Thread

Cable-Ø	Part Number
7 – 12 mm (.28 – .47")	7.110.500.000
11 – 17 mm (.43 – .67")	7.110.600.000

▶
▶
▶
▶
▶
▶

Straight Connector, Male Thread

Cable-Ø	Part Number
7 – 12 mm (.28 – .47")	7.210.500.000
11 – 17 mm (.43 – .67")	7.210.600.000

▶
▶
▶
▶
▶
▶

Panel Connector, Male Thread, front mounting

Type	Part Number
4 x holes 3,2 mm	7.410.700.000

▶
▶
▶
▶
▶
▶



Housing without inserts and contacts



Inserts 26-pole

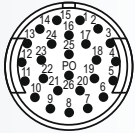

Insert pin mating view

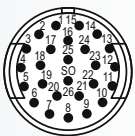

Insert socket mating view

Type	Part Number	Part Number
Pinout clockwise	Pins	Sockets
Insert with solder contacts.....	7.001.926.103	7.001.926.104
Insert without contacts	7.003.926.101	7.003.926.102

Insert with dip solder contacts
Length 10 mm7.001.926.127

The correct dimension of a connector with dip solder contacts depends on the particular type of housing.



Inserts 28-pole



Insert pin mating view

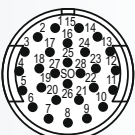

Insert socket mating view

Type	Part Number	Part Number
Pinout clockwise	Pins	Sockets
Insert with solder contacts.....	7.001.928.103	7.001.928.104









Required Contacts / Contacts

Contact Arrangement	Number of Poles	Required Contacts
	2626 x 1 mm

Contacts	Type	Crimp Range	Part Number
	Crimp pin 1 mm, machined.....0,14 – 0,56 mm ² (AWG 26 – 17)7.010.971.001
	Crimp socket 1 mm, machined.....0,14 – 0,56 mm ² (AWG 26 – 17)7.010.971.002

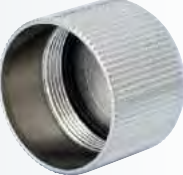

Accessories

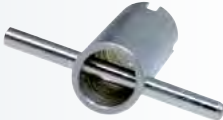
Accessories	Type	Part Number
	Plastic protective cap for connectors with male thread	7.000.980.167
	with female thread	7.000.980.168
	Brass protective cap for connectors with female thread	7.010.900.169
	Brass protective cap with chain for connectors with female thread Length 70 mm	7.010.950.707
	Brass protective cap for connectors with male thread	7.010.900.170
	Brass protective cap with chain for connectors with male thread Length 70 mm	7.010.950.708
	Crimp tool for manual crimping of machined crimp contacts Works with contacts for power or signal	7.000.900.901 / 904
		
	Assembly tool	7.010.900.110



Crimp Tool Setting for HUMMEL Crimp Contacts (Crimp Tool 7.000.900.901)

Part Number	Crimp Contact	Cross Section (mm ²)	AWG	Crimp Tool Setting mm	Locator Setting
7.010.971.001	Crimp pin 1 mm, M27	0,14	26	0,68	11
		0,22	24	0,70	11
		0,38	22	0,72	11
		0,56	20	0,74	11
7.010.971.002	Crimp socket 1 mm, M27	0,14	26	0,68	12
		0,22	24	0,70	12
		0,38	22	0,72	12
		0,56	20	0,74	12

These values are only guidelines and actual conductor cross sections depend on manufacturer tolerances.



Straight Connector, Female Thread

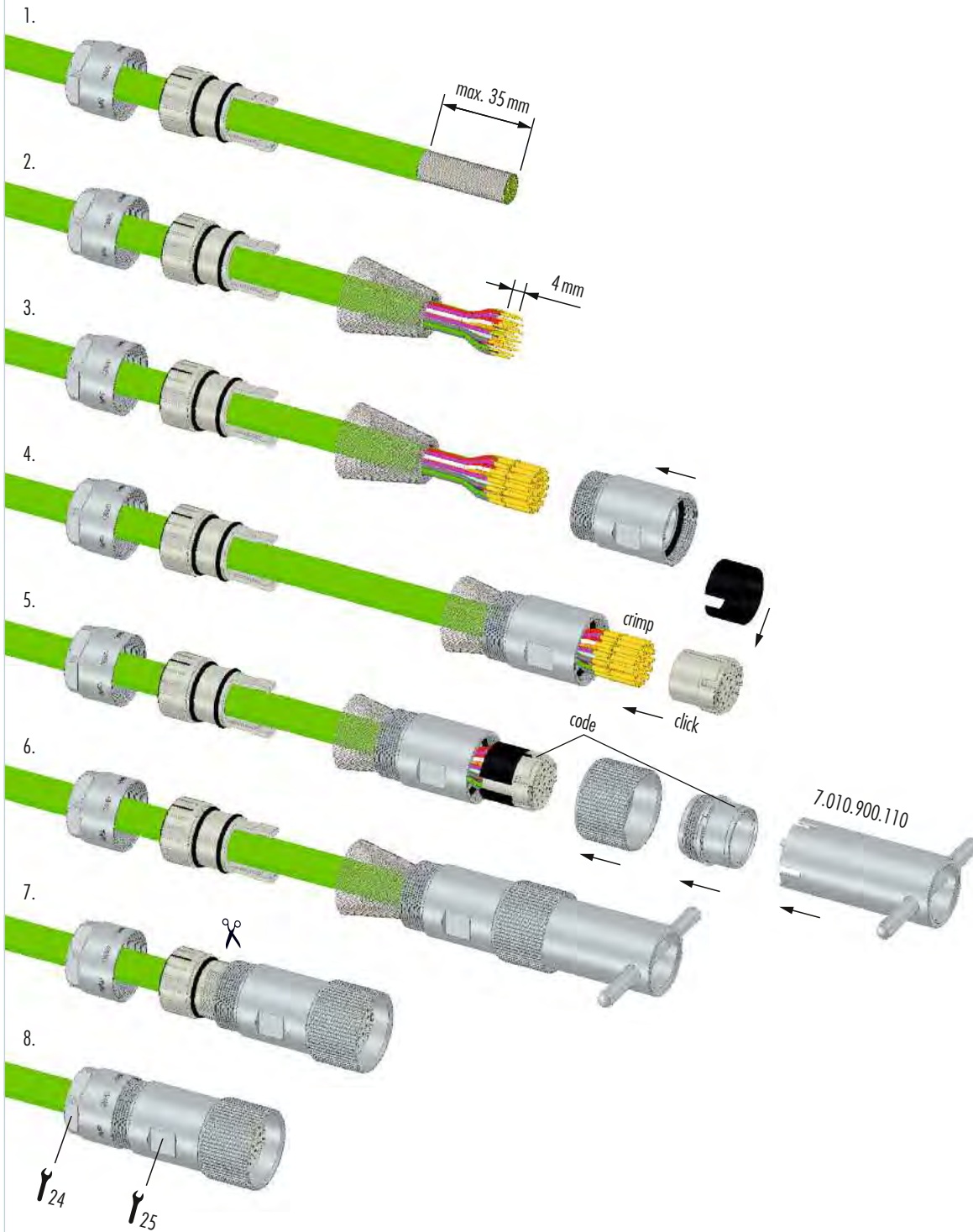

M 12

M 16

M 23 PoE

M 23 RJ45

M 23 Signal

M 27 Signal

M 23 Power

M 40 Power

INOX

Moulded Cordsets

Customized



Assembly Instructions

Panel Connector

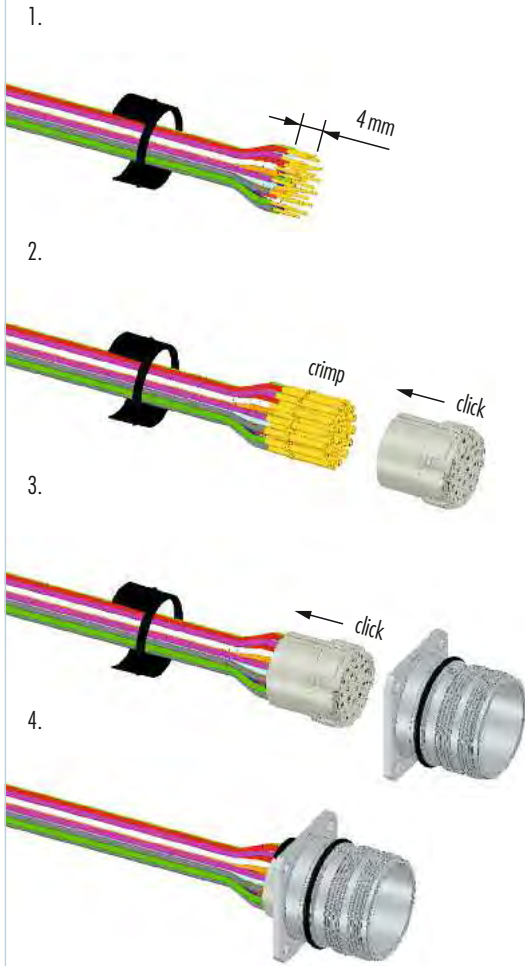

M 23 POWER, M 23 HYBRID

The classical M 23 Power connector is able to cover a large range of applications. This connector meets almost every challenge, because it can be used with 6-, 8- or 9-pole inserts and the power data goes up to 28 A / 600 V.

- // High power transmission
- // Screw lock or TWILOCK/TWILOCK-S quick release fastener
- // Numerous housing types



Product overview

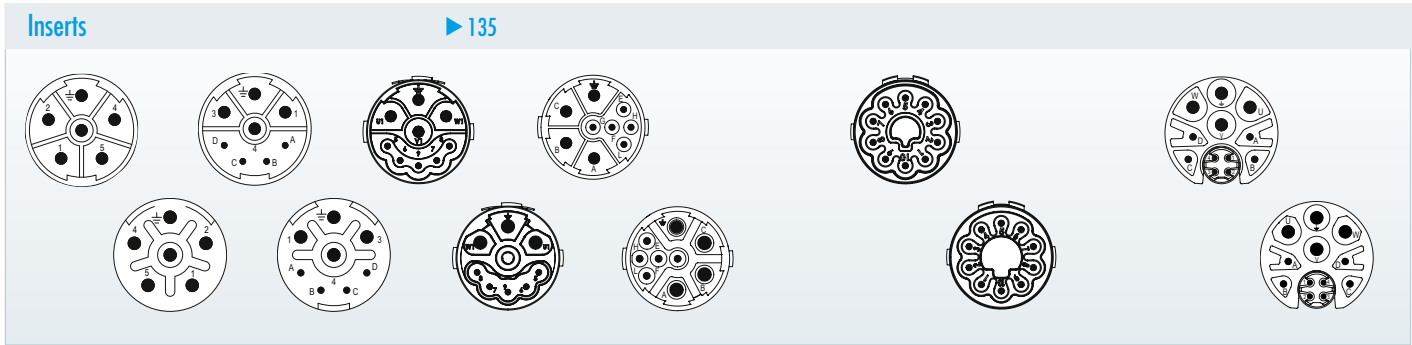

Mechanical Data	Materials and Technical Data
Housing	Copper-Zinc alloy Die Cast
Housing surface	Nickel plated other surface upon request
Inserts (for contacts)	Thermoplastic Polyamid PA 6 (Nylon 6/6), PBT Fire protection class V-0
Contacts	Brass Alloy
Contact surface at point of contact	Nickel and gold plated (0,25 µm)
Minimum mating cycles	> 1000*
Seals / O-Rings	Buna-N standard optional Viton® (FKM / FPM) (Viton is a registered trademark of DuPont)
Temperature range	-40 °C – 125 °C (-40 °F – 257 °F)
Type of contacts	Crimp
Protection	IP 67 / IP 69K per EN 60 529 (connected), NEMA 4x
Cable diameter range	7 – 17 mm (.28 – .67")

* HUMMEL to HUMMEL connector

Electrical Data						
Number of positions	5 + PE	4 + 3 + PE		5 + 3 + PE	10	
Number of contacts	6	4	4	5	4	10
Contact-Ø [mm]	2	1	2	1	2	1
Nominal current ¹⁾ [A]	28	8	28	10	28	10
Nominal voltage ²⁾ [V~] Degree of Protection 3 ³⁾	600	300	600	250	600	160
Test voltage (Breakdown voltage) ⁴⁾ [V~]	4000	2500	4000	2500	4000	2500
Insulation resistance [Ω]	> 10 ¹³	> 10 ¹³		> 10 ¹³		> 10 ¹³
Max. contact resistance [mΩ]	3	3		3		3
Number of positions	4 + 4 + 3 + PE					
	Power	Signal		Ethernet		
Number of contacts	4	4		4		
Contact-Ø [mm]	2	1		0,6		
AWG [mm ²]	0,75 – 4	0,14 – 1		0,08 – 0,34		
Nominal current ¹⁾ [A]	28	8		2		
Nominal voltage ²⁾ [V~] Degree of Protection 3 ³⁾	600	300		60		
Test voltage (Breakdown voltage) ⁴⁾ [V~]	4000	2500		500		
Insulation resistance [Ω]	> 10 ¹³	> 10 ¹⁰		> 10 ⁶		
Max. contact resistance [mΩ]	< 3	< 3		< 3		

^{1), 2), 3), 4)} See Technical Information page 18



Housings

Straight Connector, Female Thread

Cable-Ø	Part Number
7 – 12 mm (.27 – .47")	7.550.500.000
11 – 17 mm (.43 – .67")	7.550.600.000

Straight Connector, Female Thread TWILOCK / TWILOCK-S*

Cable-Ø	Part Number
7 – 12 mm (.24 – .47")	7.556.500.000
11 – 17 mm (.43 – .67")	7.556.600.000

* intermateable with Speedtec

7 – 12 mm (.24 – .47")	7.556.500.00S
11 – 17 mm (.43 – .67")	7.556.600.00S

Straight Connector, Male Thread TWILOCK / TWILOCK-S*

Cable-Ø	Part Number
7 – 12 mm (.27 – .47")	7.560.500.000
11 – 17 mm (.43 – .67")	7.560.600.000

* intermateable with Speedtec

7 – 12 mm (.27 – .47")	7.566.500.000S
11 – 17 mm (.43 – .67")	7.566.600.000S

Panel Connector, Male Thread, with Strain Relief

Cable-Ø	Part Number
4 holes Ø 3,2 mm (.13"), front or rear mounting	
7 – 12 mm (.27 – .47")	7.683.500.000
11 – 17 mm (.43 – .67")	7.683.600.000

Housing without inserts and contacts

Panel Connector, Female Thread, with Strain Relief

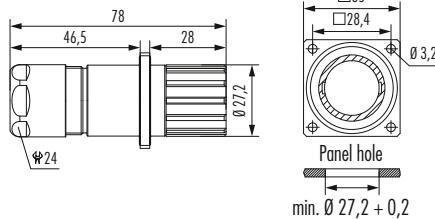

Cable-Ø

Part Number

4 holes Ø 3,2 mm (.13"), front or rear mounting

7 – 12 mm (.27 – .47")	7.681.500.000
11 – 17 mm (.43 – .67")	7.681.600.000



Panel Connector, Male Thread, with Strain Relief TWILOCK / TWILOCK-S*

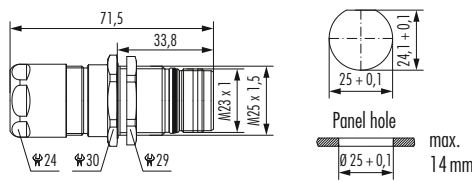

Cable-Ø

Part Number

Single hole mounted, rear mounting, thread M25 x 1,5

7 – 12 mm (.27 – .47")	7.653.500.000
11 – 17 mm (.43 – .67")	7.653.600.000

* intermateable with Speedtec

7 – 12 mm (.27 – .47")	7.653.500.00S
11 – 17 mm (.43 – .67")	7.653.600.00S

Including jam nut M25 x 1,5



Right Angle Connector, Female Thread, rotatable

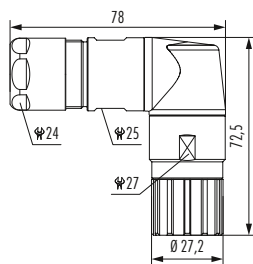

Cable-Ø

Part Number

7 – 12 mm (.27 – .47")	7.576.500.000
11 – 17 mm (.43 – .67")	7.576.600.000



Right Angle Connector, Male Thread, rotatable

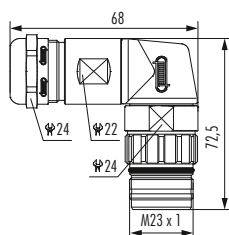

Cable-Ø

Part Number

7 – 12 mm (.27 – .47")	7.580.500.000 ¹
10 – 14 mm (.39 – .55")	7.580.600.000 ¹



Housing without inserts and contacts

¹ no compatibility with TWILOCK



Housings

Panel Connectors, Male Thread, Front Mounting TWILOCK/TWILOCK-S*



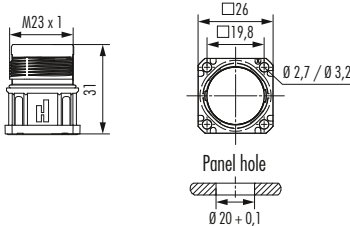

Type	Part Number
4 holes Ø 3,2 mm (.13")	7.601.000.000
4 holes Ø 2,7 mm (.11")	7.605.000.000
* intermateable with Speedtec	
4 x holes 3,2 mm, Flange 25x25	7.601.000.005
4 x holes 3,2 mm, Flange 28x28	7.601.100.005



Panel Connector with knurled Nut, Front Mounting



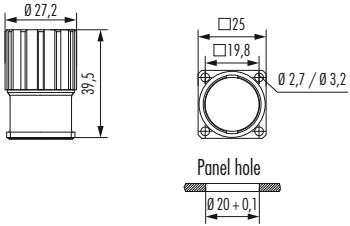

Type	Part Number
4 holes Ø 3,2 mm (.13")	7.641.000.000
4 holes Ø 2,7 mm (.11")	7.645.000.000



Panel Connector, Male Thread, Rear Mounting



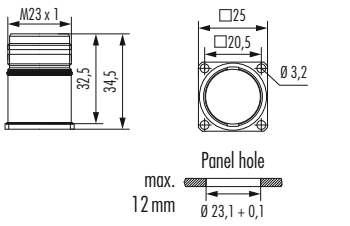

Type	Part Number
With anti-vibration O-Ring	
4 holes Ø 3,2 mm (.13")	7.661.000.000 ¹





Housing without inserts and contacts

¹ No compatibility with TWILOCK

Panel Connector, Male Thread, Single Hole Mounted

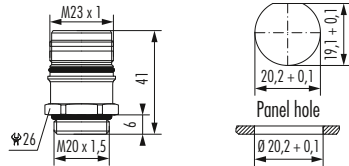

Type Part Number

Front mounting
Thread M 20 x 1,57.621.000.000¹

Option: jam nut M 20 x 1,5



Panel Connector, Male Thread, Single Hole Mounted

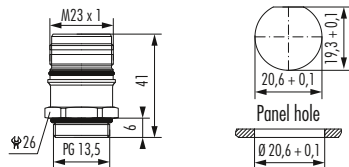

Type Part Number

Front mounting
Thread PG 13,57.623.000.000¹

Option: jam nut PG 13,5



Panel Connector, Male Thread, Single Hole Mounted

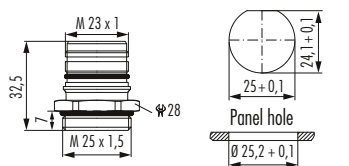

Type Part Number

Front mounting
Thread M 25 x 1,57.626.000.000

Option: jam nut M 25 x 1,5



Panel Connector, Male Thread, Single Hole Mounted

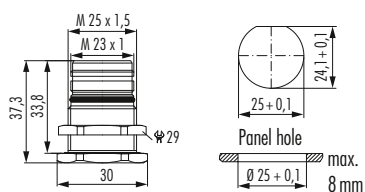

Type Part Number

Rear mounting
Thread M 25 x 1,57.651.000.000

Including jam nut M 25 x 1,5



Housing without inserts and contacts

¹ No compatibility with TWILOCK



Housings

Right Angle Panel Connector, Male Thread

Type	Part Number
4 holes \varnothing 2,7 mm (.11")	7.635.000.000

Optional: Flat gasket

Easy fastening with M2,5 x 10 mm or 4 x .39" long screws

Right Angle Panel Connector, Male Thread, rotatable

Type	Part Number
335° rotatable, single hole mounted	
Thread M 20 x 1,5	7.636.000.000

Right Angle Panel Connector, Male Thread, rotatable TWILOCK/TWILOCK-S*

Type	Part Number
330° rotatable, single hole mounted	
4 x holes 3,2 mm (.13")	7.639.000.000
Flange 25 x 25 mm	
* intermateable with Speedtec	
4 x holes 3,2 mm (.13")	7.639.000.00S
Flange 25 x 25 mm	







Right Angle Panel Connector, Male Thread, rotatable TWILOCK/TWILOCK-S*

Type	Part Number
330° rotatable, single hole mounted	
4 x holes 3,2 mm (.13")	7.639.100.000
Flange 28 x 28 mm	
* intermateable with Speedtec	
4 x holes 3,2 mm (.13")	7.639.100.00S
Flange 28 x 28 mm	

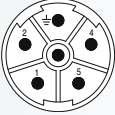
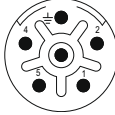
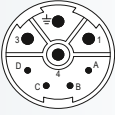
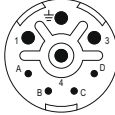
Housing without inserts and contacts

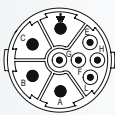
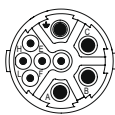

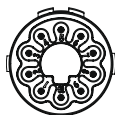
Required Contacts

Contact Arrangement, Mating View		Number of Poles	Required Contacts
 crimp pin	 crimp socket	6 x crimp pins 2 mm 6 x crimp sockets 2 mm.....7.084.951.121 ¹⁾7.084.951.122 ¹⁾
 crimp pin	 crimp socket	4 x crimp pins 1 mm, 4 x crimp pins 2 mm 4 x crimp sockets 1 mm, 4 x crimp sockets 2 mm.....7.084.943.1217.084.943.122
 crimp pin	 crimp socket	5 x crimp pins 1 mm, 4 x crimp pins 2 mm 5 x crimp sockets 1 mm, 4 x crimp sockets 2 mm.....7.084.953.1017.084.953.102
 crimp pin	 crimp socket	5 x crimp pins 1 mm, 4 x crimp pins 2 mm 5 x crimp sockets 1 mm, 4 x crimp sockets 2 mm.....7.084.909.1017.084.909.102
 crimp pin	 crimp socket	10 x crimp pins 1 mm..... 10 x crimp sockets 1 mm.....7.084.910.1017.084.910.102
 crimp pin	 crimp socket	4 x crimp pins 1 mm, 4 x crimp pins 2 mm, 4 x crimp pins 0,6 mm..... 4 x crimp sockets 1 mm, 4 x crimp sockets 2 mm, 4 x crimp sockets 0,6 mm.....7.084.944.1017.084.944.102

¹⁾ under development



Contacts

Contacts	Type	Crimp Range	Part Number
	Crimp pin 0,6 mm, machined ¹	0,08 – 0,34 mm ² (AWG28 – AWG 22)	7.010.980.641
	Crimp socket 0,6 mm, machined ¹	0,08 – 0,34 mm ² (AWG28 – AWG 22)	7.010.980.602
	Crimp pin 1 mm, machined ²	0,14 – 1 mm ² (AWG 26 – 17)	7.010.941.001
	Crimp pin 1 mm, machined ²	0,75 – 1,5 mm ² (AWG 18 – 16)	7.010.941.021
	Crimp socket 1 mm, machined ²	0,14 – 1 mm ² (AWG 26 – 17)	7.010.941.002
	Crimp socket 1 mm, machined ²	0,75 – 1,5 mm ² (AWG 18 – 16)	7.010.941.022
	Crimp pin 2 mm, machined ²	0,75 – 2,5 mm ² (AWG 18 – 14)	7.010.942.001
	Crimp pin 2 mm, machined ²	2,5 – 4 mm ² (AWG 14 – 12)	7.010.942.011
	Crimp socket 2 mm, machined ²	0,75 – 2,5 mm ² (AWG 18 – 14)	7.010.942.002
	Crimp socket 2 mm, machined ²	2,5 – 4 mm ² (AWG 14 – 12)	7.010.942.012







¹ passende Crimpzange 7.000.900.907, Crimpzangeneinstellung siehe Seite 71

² passende Crimpzange 7.000.900.901, Crimpzangeneinstellung siehe Seite 139



Accessories

Accessories	Type	Part Number
	Plastic protective cap for connectors with male thread	7.000.900.101
	with female thread	7.000.900.102
	Brass protective cap for connectors with female thread	7.010.900.183 ¹
	Brass protective cap for connectors with male thread	7.010.900.102
	Brass protective cap with chain for connectors with female thread Length 70 mm	7.010.950.783 ¹
	Length 100 mm	7.010.951.083 ¹
	Brass protective cap with chain for connectors with male thread Length 70 mm	7.010.950.702
	Length 100 mm	7.010.951.002
	Crimp tool for manual crimping of machined crimp contacts Works with contacts for power or signal	7.000.900.901
	Adaptor flange for Straight Connectors	7.010.900.128 ¹

¹ No compatibility with TWILOCK



Accessories

Accessories	Type	Part Number
	Adapter for Conduit Fittings	
	Poleon DN 12	7.010.900.205
	Poleon DN 14	7.010.900.207
	Poleon DN 17	7.010.900.209
	Positioner for Crimp Tool	
	DMC M22520	7.000.900.DMC
	Locator for Crimp Tool DMC M22520 with positioner	7.000.9DM.C06
	For HUMMEL Contact: 7.010.941.001, 7.010.942.001, 7.010.942.011	
	Locator for Crimp Tool DMC M22520 with positioner	7.000.9DM.C07
	For HUMMEL Contact: 7.010.941.002, 7.010.942.002, 7.010.942.012	
	Disassembly Tool	
	for crimp contacts	7.010.900.531
	Screw Tool, adjustable 0.5 – 1.7 Nm	7.010.900.190
	Tool Adapter for tightening or loosening	
	knurled nuts for M23	7.010.900.192
	Crimping tool	
	pneumatic crimping tool	on request
	Crimping machine	
crimping machine to process turned contacts	on request	



Crimp Tool Setting for HUMMEL Crimp Contacts (Crimp Tool 7.000.900.901)

Part Number	Crimp Contact	Cross Section (mm ²)	AWG	Crimp Tool Setting mm	Locator Setting
7.010.941.001	Crimp pin (power) 1 mm	0,14	26	0,75	1
		0,25	24	0,8	1
		0,35	22	0,85	1
		0,50	20	1,03	1
		0,75	18	1,08	1
		1,0	17	1,13	1
7.010.941.021	Crimp pin (power) 1 mm	0,75	18	0,79	1
		1	17	0,86	1
		1,5	16	0,99	1
7.010.941.002	Crimp socket (power) 1 mm	0,14	26	0,75	2
		0,25	24	0,8	2
		0,35	22	0,85	2
		0,50	20	0,89	2
		0,75	18	0,95	2
		1	17	1,02	2
7.010.941.022	Crimp socket (power) 1 mm	0,75	18	0,79	2
		1	17	0,86	2
		1,5	16	0,99	2
7.010.942.001	Crimp pin (power) 2 mm	0,75	18	1,3	7
		1	17	1,4	7
		1,5	16	1,55	7
		2,5	14	1,7	7
7.010.942.011	Crimp pin (power) 2 mm	2,5	14	1,47	7
		4	12	1,6	7
7.010.942.002	Crimp socket (power) 2 mm	0,75	18	1,3	8
		1	17	1,4	8
		1,5	16	1,55	8
		2,5	14	1,7	8
7.010.942.012	Crimp socket (power) 2 mm	2,5	14	1,47	8
		4	12	1,6	8



These values are only guidelines and actual conductor cross sections depend on manufacturer tolerances.

M12
M16
M23 PoE
M23 RJ45
M23 Signal
M27 Signal
M23 Power
M40 Power
INOX
Moulded Cordsets
Customized



Crimp Tool for Power Connectors M 23

Crimp Tool	Type	Part Number
	Crimp Tool7.000.900.901	
	Application The four indent crimp tool 7.000.900.901 has been developed for optimal crimping of machined contacts with diameters from 0.14 to 6.0 mm ² (26 through 10 AWG).	
	How to Crimp The reference table (S. 139) indicates the correct locator position to be selected and the crimp depth to be adjusted for the contact to be crimped. The contact is then inserted through the access hole of the tool on the opposite side of the locator. The contact is held in place by closing the handles to the first lock-in position thus preventing the contact from falling out of the tool and facilitating insertion of the wire into the contact. The precision ratchet assures consistently accurate crimping every time by forcing the tool to be closed all the way completing the crimping cycle before the tool can be opened again.	
	Exchange of the Locator The locator can be exchanged by removing the socket head cap screw with a socket wrench. It can then be disassembled from the hex head screw by turning it counter-clockwise.	

These values are only guidelines and actual conductor cross sections depend on manufacturer tolerances.



Crimp Tool



Adjustment of Crimp Depth

Crimp depth can be adjusted as follows:

Turn the adjusting screw clockwise for reducing the crimp depth and counter-clockwise for increasing the crimp depth.

Adjustment Increments

- // 1 space on the adjusting screw $\hat{=}$ adjustment by 0.01 mm
- // 1 full rotation of adjusting screw $\hat{=}$ adjustment by 0.2 mm (indication on the screw as well as on the rough scale)
- // 5 rotations of the adjusting screw $\hat{=}$ adjustment by 1 mm (indication on the scale)

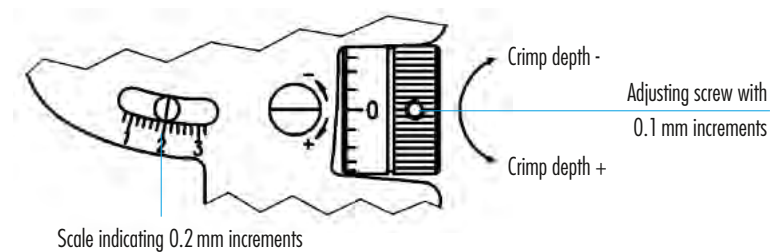

Control of Crimp Depth

Crimp tool adjustment is done at the factory, but with frequent use, periodic calibration is recommended to insure accuracy. This is easily accomplished with a 2.0 mm \emptyset wire gauge as follows. A crimp depth of 2.0 mm is set by means of the adjusting screw (scale mark at „2“, screw mark at „0“ as shown in the fig. above) and the tool in the closed position.

After insertion of the gauge, there must be just enough space for moving the gauge inside the entry hole. If the opening is too small or too large to exactly match the gauge, the deviation (+/-) can be checked by the precision setting of the screw. Please contact the factory in case the deviation exceeds the tolerances specified by the contract manufacturer.

Maintenance and Repair

Keep the tool clean and properly stored when not in service. All pivot points need to be oiled regularly and the spring clips securing the bolts have to always be in place. For repair please send the tool back to the factory.



Assembly Instructions

Straight Connector, Female Thread

1. max. 37 mm
2.

⚠ x Contact ø 1 mm = max. 4 mm stripping length
Contact ø 2 mm = max. 7 mm stripping length
3. crimp
4. click
5. click
6. 1x PE click
7.

⚠ Shield is not allowed to touch second O-ring
8. 24 24



Straight Connector, Female Thread 4+3+PE/5+3+PE

1. max. 37 mm
2. x
3. **!** x
 Contact \varnothing 1 mm = max. 4 mm stripping length
 Contact \varnothing 2 mm = max. 7 mm stripping length
4. crimp
5. click
6. click
7. scissors
8. 24 25

! Shield is not allowed to touch second O-ring



Assembly Instructions

Hybrid Connector

- max. 40 mm
- max. 5 mm
- max. 7 mm
4x Power
- max. 5 mm
4x Signal
- crimp (4x Power)
crimp (4x Signal)
- max. 30 mm

⚠ For socket insert strip the shield to max. 12 mm instead of 16 mm

max. 16 mm

max. 4 mm
4x Ethernet
- crimp
4x Ethernet contacts
- TIP: Put metal ring over conductors between step 5 & 6
- click
- Wrap copper tape to reach 5 mm outer diameter

⚠ Shielding braid and copper tape must at least 0,5 mm protrude over crimp area

7.000.900.912

crimp

crimp metal ring over crimped area

put shrinking tube over crimped area

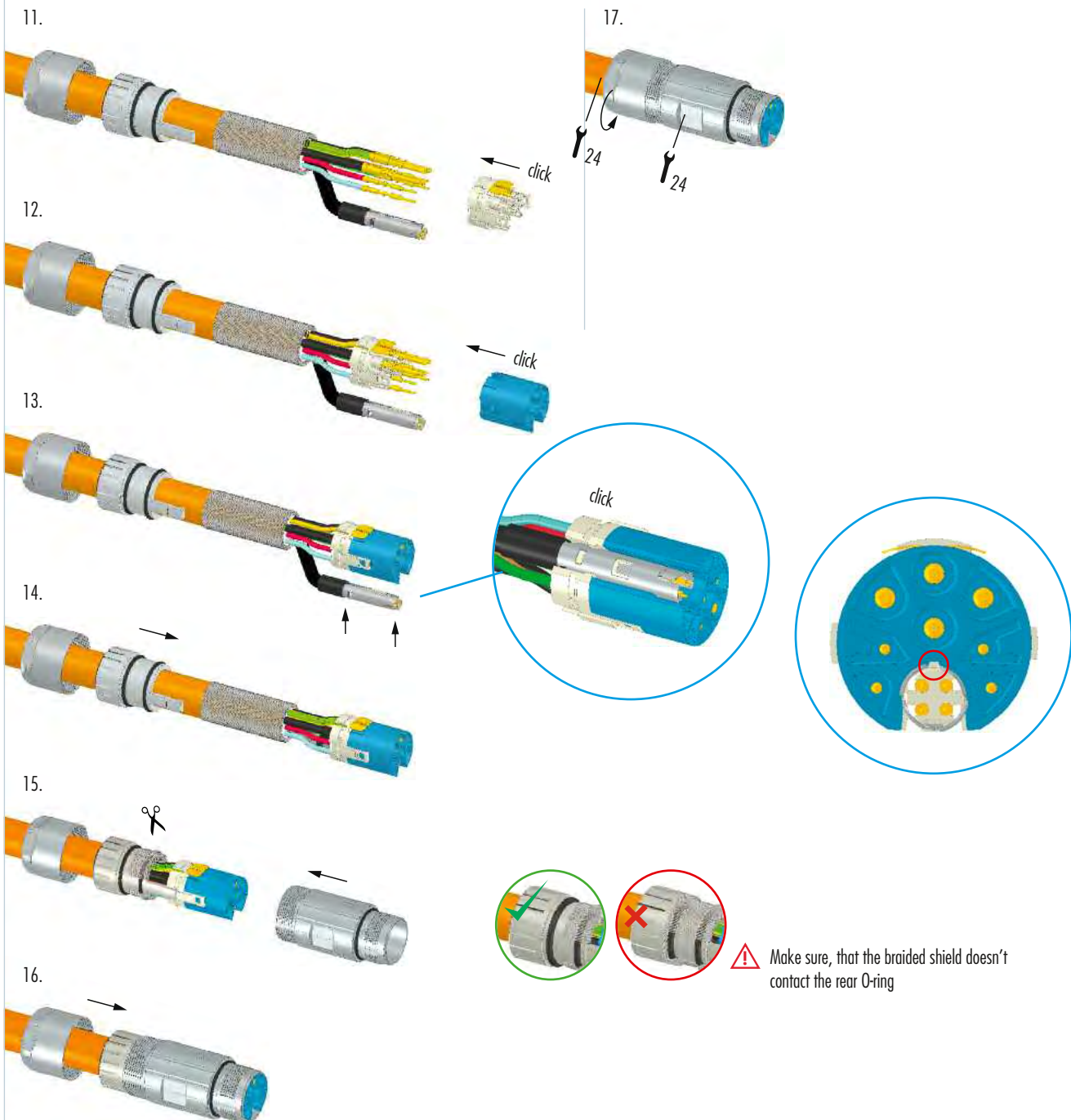



Assembly Instructions

Right Angle Connector, rotatable

1. 65 mm

2.

3.

4. **!** x Contact \varnothing 1 mm = max. 4 mm stripping length
Contact \varnothing 2 mm = max. 7 mm stripping length

5. crimp

6. click

7.

8. click

9. 1 x PE click

10. click

11. scissors

12. 24, 25, 27

! Make sure, that the braided shield doesn't contact the rear O-ring

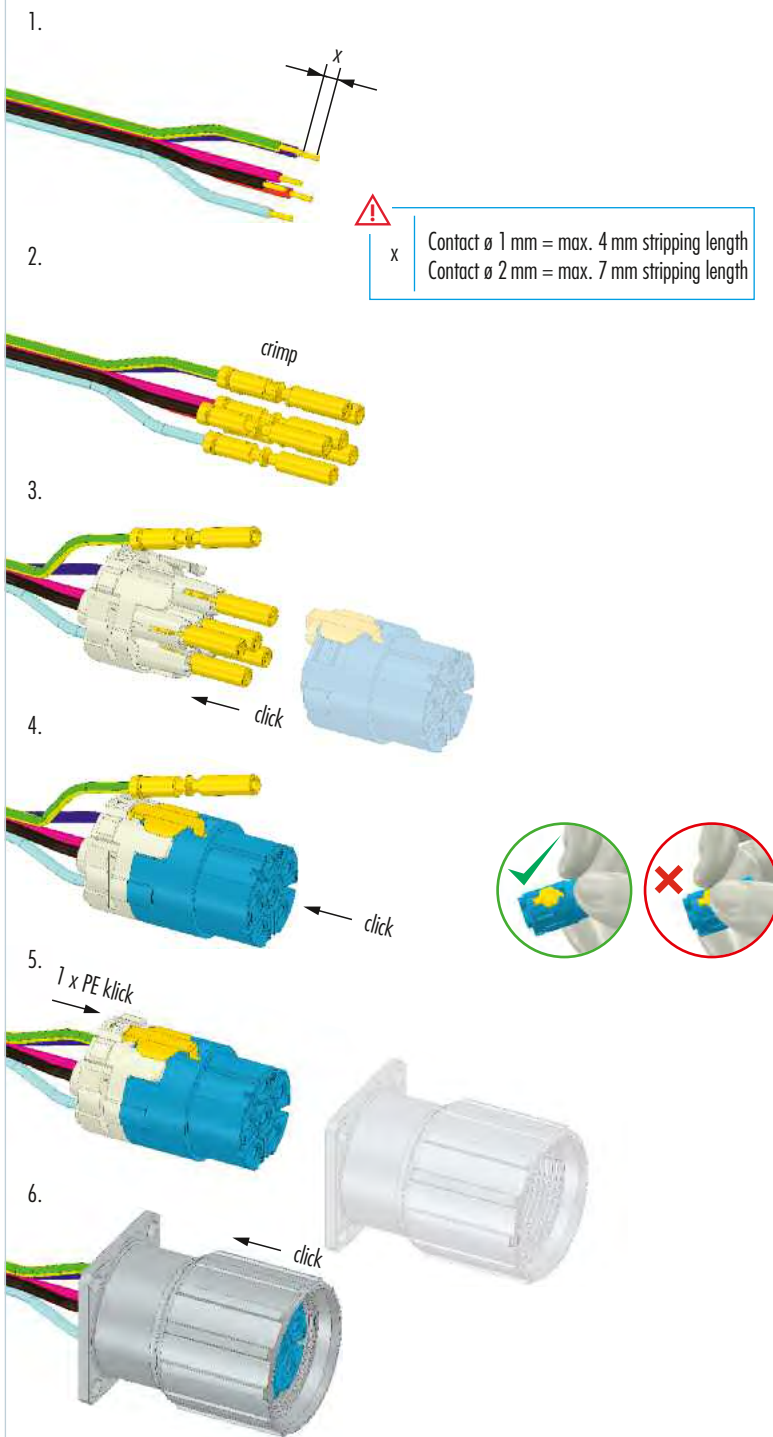

M 12
M 16
M 23 PoE
M 23 RJ45
M 23 Signal
M 27 Signal
M 23 Power
M 40 Power
INOX
Moulded Cordsets
Customized



Assembly Instructions

Panel Connector, Male Thread, Single Hole Mounted

- 1.
- 2.
- 3.
- 4.
- 5.
- 6.

x Contact \varnothing 1 mm = max. 4 mm stripping length
 Contact \varnothing 2 mm = max. 7 mm stripping length



Assembly Instructions

Panel Connector, Male Thread

- 1.
2.

x Contact \varnothing 1 mm = max. 4 mm stripping length
 Contact \varnothing 2 mm = max. 7 mm stripping length
- 3.
4.
- 5.
- 6.

M 12
M 16
M 23 PoE
M 23 RJ45
M 23 Signal
M 27 Signal
M 23 Power
M 40 Power
INOX
Moulded Cordsets
Customized



Assembly Instructions

Right Angle Panel Connector TWILOCK-S

1.
 x Contact \varnothing 1 mm = max. 4 mm stripping length
 Contact \varnothing 2 mm = max. 7 mm stripping length

2.
 crimp

3.
 click

4.
 click click

5.
 click

6.

7.
 PE
 click

8.
 TORX: T10
 max. 2,7 Nm

9.

 If using TWILOCK-S or Speedtec plug you have to remove O-Ring.



Right Angle Panel Connector TWILOCK

1.

2. **crimp**

3. **click click**

⚠ x

Contact \varnothing 1 mm = max. 4 mm stripping length
 Contact \varnothing 2 mm = max. 7 mm stripping length

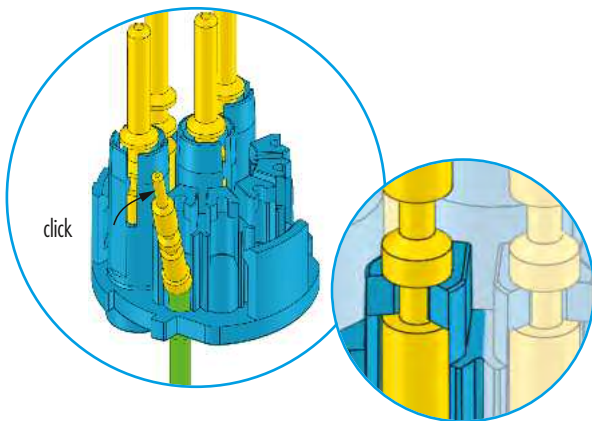

4. **click**

5. **click**

6.

7. **T10**
max. 2,7 Nm



Crimping, Assembly and Disassembly of Contacts

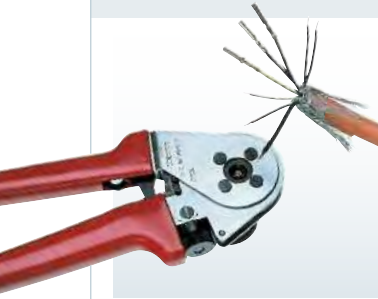

Crimping

- For 1 mm contacts strip wire ends 4 mm (.16") max., for 2 mm contacts strip wire ends 7 mm (.28") max.
- // Dial appropriate setting of crimping tool
- // Push crimp contact into opening of crimping tool
- // Insert stripped wire into the funnel shaped end of the crimp contact
- // Squeeze handles of crimping tool together, connecting contact to wire

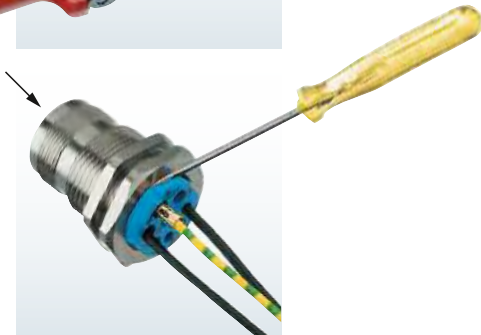

Disassembly of Insert from Housing

By using the screwdriver push the insert into the housing, start at the bottom and work your way up to the top.

Shielding

- Assemble strain relief insert with insert
- // Fold stranding of the shield back over the first O-Ring of the strain relief insert
- // Cut back the overextending braid



The wire ends of the shield may not be allowed to touch the second O-Ring.



M 40 POWER CONNECTORS (SIZE 1,5)

Connector series M 40 is suitable for high current and is preferably used for heavy drive application. The high-quality housing out of metal fulfills all requirements, that are present in a rough industrial environment. Furthermore, it convinces through a long operational lifetime.

- // suitable for requirements with high current
- // safe EMC protection



Product overview

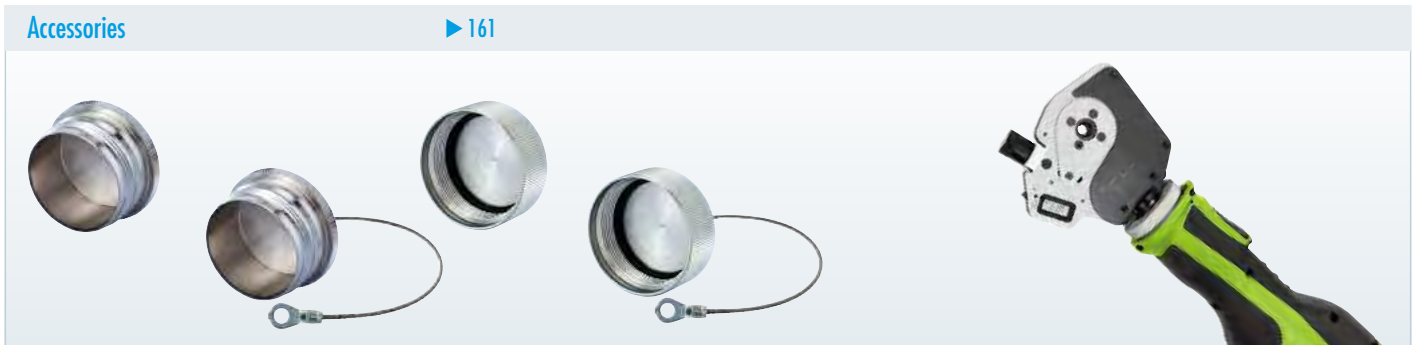

Mechanical Data	Materials and Technical Data
Housing	Copper-Zinc alloy Die Cast
Housing surface	Nickel plated, other surface upon request
Inserts (for contacts)	Thermoplastic Polyamid PA 6 (Nylon 6/6), PBT Fire protection class V-0
Contacts	Brass Alloy
Contact surface at point of contact	Nickel and gold plated (0,25 µm)
Minimum mating cycles	> 500
Seals / O-Rings	Buna-N standard optional Viton® (FKM / FPM) (Viton is a registered trademark of DuPont)
Temperature range	-40 °C – 125 °C (-40 °F – 257 °F)
Type of contacts	Crimp
Protection	IP 67 / IP 69K per EN 60 529 (connected), NEMA 4x
Cable diameter range	13 – 28 mm (.51" – 1.10")

Electrical Data	2 + 3 + PE		4 + 3 + PE	
Number of positions	2	4	4	4
Number of contacts	2	4	4	4
Contact-Ø [mm]	2	3,6	2	3,6
Nominal current ¹⁾ [A]	28	55	28	55
Nominal voltage ²⁾ [V~] Degree of Protection 3 ³⁾	300	600	300	600
Test voltage (Breakdown voltage) ⁴⁾ [V~]	2500	4000	2500	4000
Insulation resistance [Ω]	> 10 ¹³		> 10 ¹³	
Max. contact resistance [mΩ]	3	1	3	1





Standard delivery of M 40 (size 1,5) Power Connector include Contact Insert.

^{1), 2), 3), 4)} See Technical Information page 18



Housings

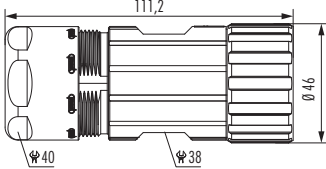

Straight Connector, Female Thread

Cable-Ø	Part Number
2 + 3 + PE, insert for sockets	
13 – 18 mm (.51 – .71")	7.710.623.000
17 – 24 mm (.67 – .97")	7.710.723.000
21 – 28 mm (.83 – 1.10")	7.710.823.000



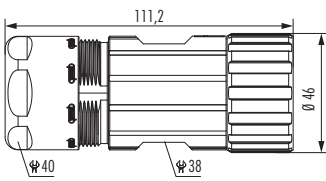

Straight Connector, Female Thread

Cable-Ø	Part Number
4 + 3 + PE, insert for sockets	
13 – 18 mm (.51 – .71")	7.710.643.000
17 – 24 mm (.67 – .97")	7.710.743.000
21 – 28 mm (.83 – 1.10")	7.710.843.000

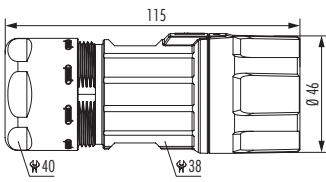

Straight Connector, Female Thread TWILOCK-S

Cable-Ø	Part Number
2 + 3 + PE, insert for sockets	
* intermateable with Speedtec	
13 – 18 mm (.51 – .71")	7.716.623.00S
17 – 24 mm (.67 – .97")	7.716.723.00S
21 – 28 mm (.83 – 1.10")	7.716.823.00S



Straight Connector, Female Thread TWILOCK-S

Cable-Ø	Part Number
4 + 3 + PE, insert for sockets	
* intermateable with Speedtec	
13 – 18 mm (.51 – .71")	7.716.643.00S
17 – 24 mm (.67 – .97")	7.716.743.00S
21 – 28 mm (.83 – 1.10")	7.716.843.00S

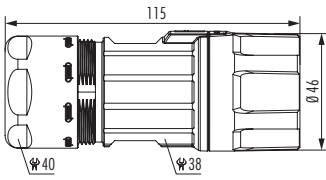
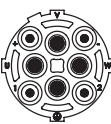

Straight Connector, Male Thread TWILOCK-S*

Cable-Ø

Part Number

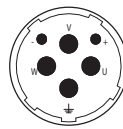
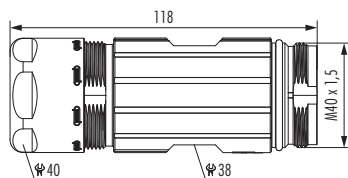

2 + 3 + PE, insert for pins	
13 – 18 mm (.51 – .71")	7.720.623.000
17 – 24 mm (.67 – .97")	7.720.723.000
21 – 28 mm (.83 – 1.10")	7.720.823.000
* intermateable with Speedtec	
13 – 18 mm	7.720.623.00S
17 – 24 mm	7.720.723.00S
21 – 28 mm	7.720.823.00S



Straight Connector, Male Thread TWILOCK-S*

Cable-Ø

Part Number

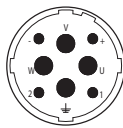
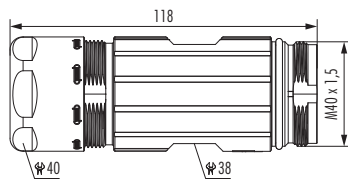

4 + 3 + PE, insert for pins	
13 – 18 mm (.51 – .71")	7.720.643.000
17 – 24 mm (.67 – .97")	7.720.743.000
21 – 28 mm (.83 – 1.10")	7.720.843.000
* intermateable with Speedtec	
13 – 18 mm	7.720.643.00S
17 – 24 mm	7.720.743.00S
21 – 28 mm	7.720.843.00S



Panel Connector, Male Thread, Front Mounting TWILOCK-S*

Type

Part Number

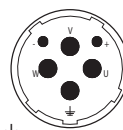
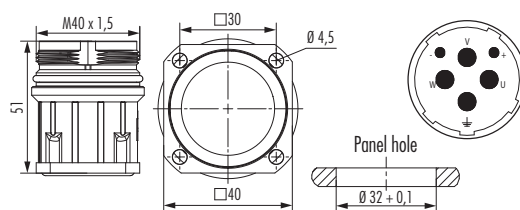

2 + 3 + PE, insert for pins	
4 holes Ø 4,5 mm (.18")	7.740.023.000
* intermateable with Speedtec	
4 x Bohr. 4,5 mm	7.740.023.00S



Panel Connector, Male Thread, Front Mounting TWILOCK-S*

Type

Part Number

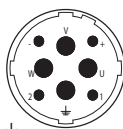
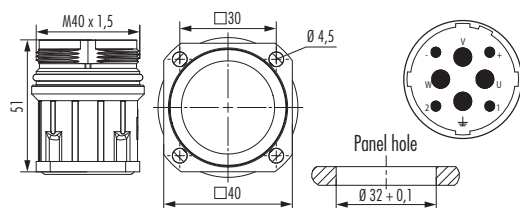

4 + 3 + PE, insert for pins	
4 holes Ø 4,5 mm (.18")	7.740.043.000
* intermateable with Speedtec	
4 x Bohr. 4,5 mm	7.740.043.00S





Housings

Panel Connector with knurled Nut, Front Mounting

Type **Part Number**

2 + 3 + PE, insert for sockets
4 holes Ø 4,5 mm (.18")7.744.023.000

Panel Connector with knurled Nut, Front Mounting

Type **Part Number**

4 + 3 + PE, insert for sockets
4 holes Ø 4,5 mm (.18")7.744.043.000

Right Angle Panel Connector, Male Thread, rotatable TWILOCK-S*

Type **Part Number**

2 + 3 + PE, insert for pins
* intermateable with Speedtec
4 holes Ø 4,5 mm (.18")7.749.023.005

Right Angle Panel Connector, Male Thread, rotatable TWILOCK-S*

Type **Part Number**

4 + 3 + PE, insert for pins
* intermateable with Speedtec
4 holes Ø 4,5 mm (.18")7.749.043.005

¹ under development



Panel Connector, Male Thread, Single Hole Mounting		Type	Part Number
			Front mounting, 2 + 3 + PE, insert for pins Thread M 40 x 1,57.742.023.000

Panel Connector, Male Thread, Single Hole Mounting		Type	Part Number
			Front mounting, 4 + 3 + PE, insert for pins Thread M 40 x 1,57.742.043.000

Contact Arrangement, Mating View	Number of Poles	Required Contacts
	Insert for pins 2 + 3 + PE	2 x crimp pins 2 mm 4 x crimp pins 3,6 mm
	Insert for sockets 2 + 3 + PE	2 x crimp sockets 2 mm 4 x crimp sockets 3,6 mm
	Insert for pins 4 + 3 + PE	4 x crimp pins 2 mm 4 x crimp pins 3,6 mm
	Insert for sockets 4 + 3 + PE	4 x crimp sockets 2 mm 4 x crimp sockets 3,6 mm

Standard delivery of M 40 (size 1,5) Power Connector include Contact Insert.









Contacts

Contacts	Type	Crimp Range	Part Number
	Crimp pin 2 mm, machined	0,25 – 1 mm ² (AWG 24 – 17)	7.015.952.003 ¹
	Crimp pin 2 mm, machined	1 – 4 mm ² (AWG 17 – 12)	7.015.952.001
	Crimp socket 2 mm, machined	0,25 – 1 mm ² (AWG 24 – 17)	7.015.952.004 ¹
	Crimp socket 2 mm, machined	1 – 4 mm ² (AWG 17 – 12)	7.015.952.002
	Crimp pin 3,6 mm, machined	1,5 – 4 mm ² (AWG 16 – 12)	7.015.953.601
	Crimp socket 3,6 mm, machined	1,5 – 4 mm ² (AWG 16 – 12)	7.015.953.602
	Crimp pin 3,6 mm, machined	6 mm ² (AWG 10)	7.015.953.611
	Crimp socket 3,6 mm, machined	6 mm ² (AWG 10)	7.015.953.612
	Crimp pin 3,6 mm, machined	AWG 8	7.015.953.621
	Crimp pin 3,6 mm, machined	10 mm ²	7.015.953.623
	Crimp socket 3,6 mm, machined	AWG 8	7.015.953.622
	Crimp socket 3,6 mm, machined	10 mm ²	7.015.953.624
	Crimp pin 3,6 mm, machined	16 mm ² (AWG 6)	7.015.953.631
	Crimp socket 3,6 mm, machined	16 mm ² (AWG 6)	7.015.953.632

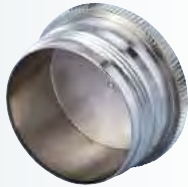

¹ under development

Accessories	Type	Part Number
	Plastic protective cap for connectors with female thread	7.000.900.152
	Plastic protective cap for connectors with male thread	7.000.900.151
	Brass protective cap for connectors with female thread	7.015.900.103 ¹
	Brass protective cap for connectors with male thread	7.015.900.102
	Brass protective cap with rope for connectors with female thread	7.015.9S1.003 ¹
	Brass protective cap with rope for connectors with male thread	7.015.9S1.002
	Adaptor flange for Straight Connectors	7.010.900.129 ¹

¹ No compatibility with TWILOCK



Accessories

Accessories	Type	Part Number
	Adapter for Conduit Fittings	
	Poleon DN 23	7.010.900.215
	Poleon DN 29	7.010.900.217
	Manual crimp tool	
	machined crimp contacts until 10 mm ² (AWG 8) for power connectors	
	battery pack crimp tool for connectors M 40 (European market only)	7.000.900.920
	crimping unit for crimp tool	7.000.900.919
	locator for 3,6 mm contacts at crimp tool	7.010.900.153
	assembly instructions online: www.hummel.com	
	Crimp tool for manual crimping	
	of machined crimp contacts 16 mm ² (AWG 6)	7.000.900.903



Crimp Tool Setting for HUMMEL Crimp Contacts (Crimp Tool 7.000.900.920)

Part Number	Crimp Contact	Cross Section (mm ²)	AWG	Crimp Tool Setting mm	Locator Setting
7.015.952.001	Crimp pin 2 mm	0,75	18	1,31 mm	3
		1	17	1,38 mm	3
		1,5	16	1,45 mm	3
		2,5	14	1,50 mm	3
		4	12	1,60 mm	3
7.015.952.002	Crimp socket 2 mm	0,75	18	1,31 mm	4
		1	17	1,38 mm	4
		1,5	16	1,45 mm	4
		2,5	14	1,50 mm	4
		4	12	1,60 mm	4
7.015.953.601	Crimp pin 3,6 mm	2,5	14	1,4	1
		4	12	1,6	1
7.015.953.602	Crimp socket 3,6 mm	2,5	14	1,4	2
		4	12	1,6	2
7.015.953.611	Crimp pin 3,6 mm	6	10	1,8	1
7.015.953.612	Crimp socket 3,6 mm	6	10	1,8	2
7.015.953.621	Crimp pin 3,6 mm		8	2,6	1
7.015.953.622	Crimp socket 3,6 mm		8	2,6	2
7.015.953.623	Crimp pin 3,6 mm	10		2,7	1
7.015.953.624	Crimp socket 3,6 mm	10		2,7	2



These values are only guidelines and actual conductor cross sections depend on manufacturer tolerances.

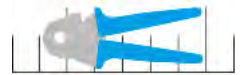

Crimp Tool Setting for HUMMEL Crimp Contacts (Crimp Tool 7.000.900.903)

Part Number	Crimp Contact	Cross Section (mm ²)	AWG	Crimp Tool Setting
7.015.953.631	Crimp pin 3,6 mm	16	6	die 16
7.015.953.632	Crimp socket 3,6 mm	16	6	die 16

These values are only guidelines and actual conductor cross sections depend on manufacturer tolerances.



Crimp Tool for M 40 Power Connectors (Size 1,5)

Crimp Tool

Type

Part Number

Crimp Tool for contacts 16 mm² (AWG 6)7.000.900.903

Application

The hand crimp tool 7.000.900.903 has been developed for optimal crimping of a large variety of connectors and terminals by using different interchangeable crimping dies.

Operation

- // Select crimp insert and install in tool
- // Insert and align crimp contact in tool
- // Compress tool until contact is held in place
- // Insert conductor into contact
- // Fully compress tool (tool will reopen automatically)
- // Remove crimped conductor from tool

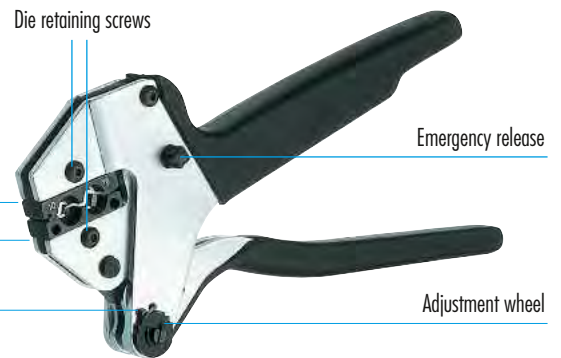

Stationary jaw with upper die

Movable jaw with lower die

Set screw

Die retaining screws

Emergency release

Adjustment wheel



Crimp Tool for M 40 Power Connectors (Size 1,5)

Crimp Tool



Adjustment of crimp force and height

Crimp force adjustment is done in the factory (120 – 180 N when unloaded). Tool frame and jaws are connected that way, an optimal crimping result will be obtained based on the hand force indicated above. In case the result (e.g. crimp height, pull-out force, etc.) does not meet the requirements of the plug manufacturer, the following reasons can be considered:

a) Normal wear of tool

Readjustment possible

b) Worn dies

Dies have to be replaced

The quality personnel is authorized to control and readjust these parameters as described below:

Unscrew the set screw by means of a screw driver

- // Rotatable the adjustment wheel anticlockwise, the crimp force increases and the crimp height decreases (+)
- // Rotatable the adjustment wheel lockwise, the crimp force decreases and the crimp height increases (-)
- // When readjusting the hand force shall not exceed 180 N
- // Before using the tool, the operator has to check the adjustment wheel being firmly secured by the set screw

Maintenance

Keep the tool clean and properly stored when not in service. The joints need to be regularly oiled and the circlips securing the bolts have to be always in place. Never use abrasives or hard material to clean the jaws. Please contact the manufacturer when the tool needs to be repaired or in case of readjustment problems.

Straight Connector, Female Thread / Male Threaded Connector

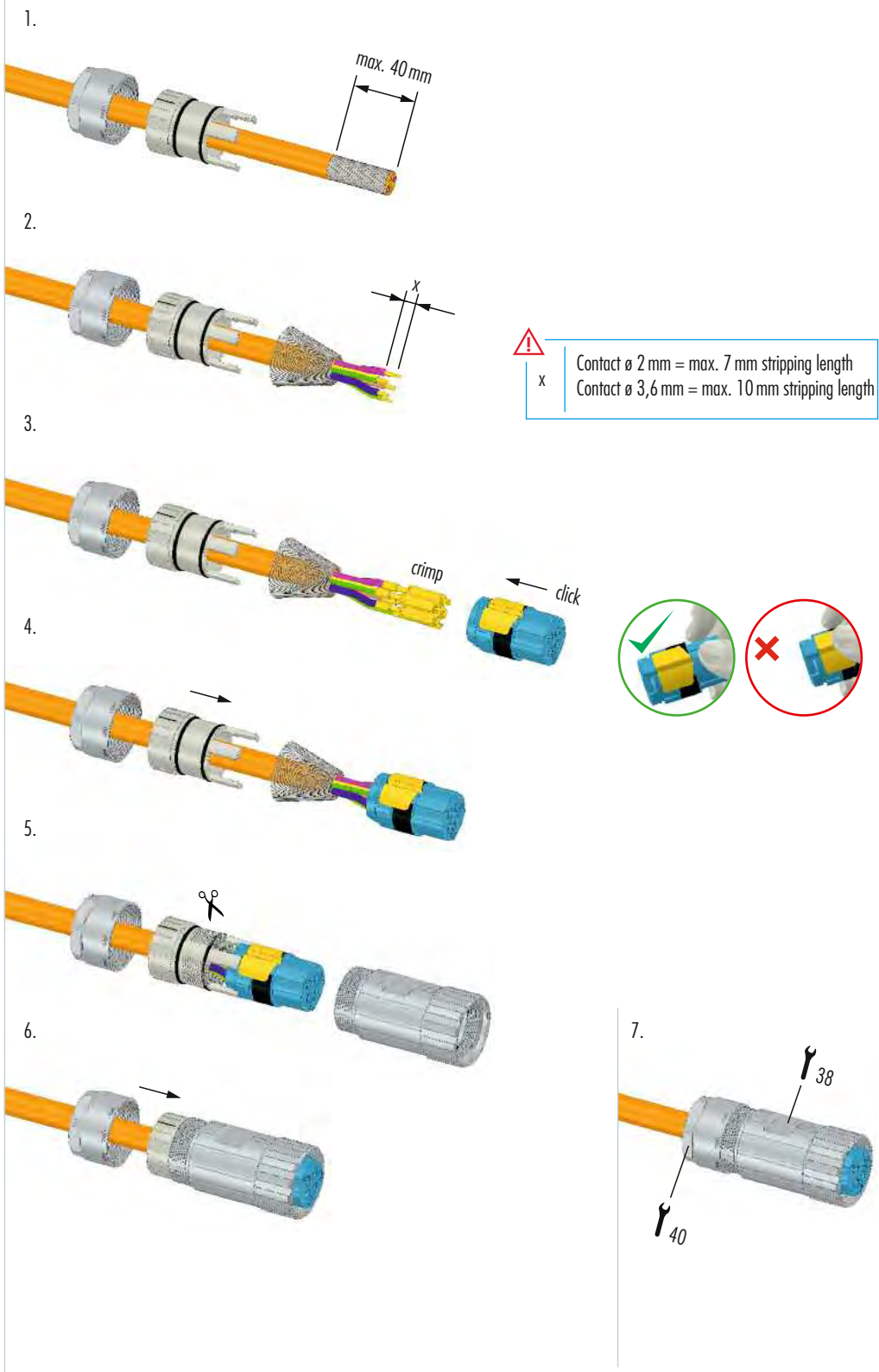

- M 12
- M 16
- M 23 PoE
- M 23 RJ45
- M 23 Signal
- M 27 Signal
- M 23 Power
- M 40 Power**
- INOX
- Moulded Cordsets
- Customized



Assembly Instructions

Panel Connector

1. 

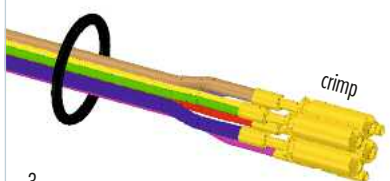
2. 

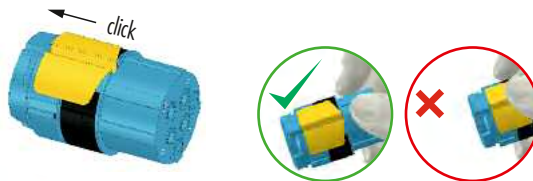
3. 

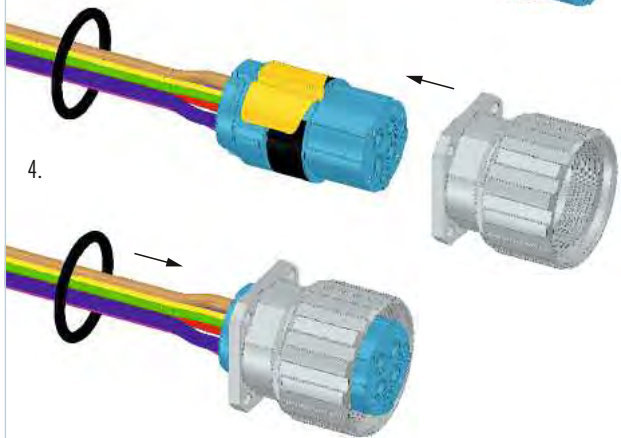
4. 

⚠
x
Contact ø 2 mm = max. 7 mm stripping length
Contact ø 3,6 mm = max. 10 mm stripping length



Right Angle Panel Connector

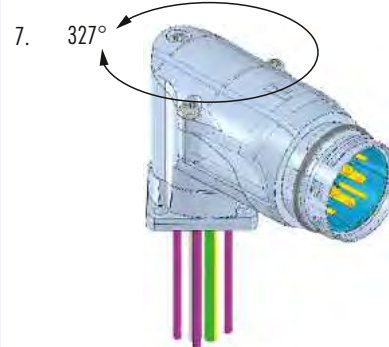
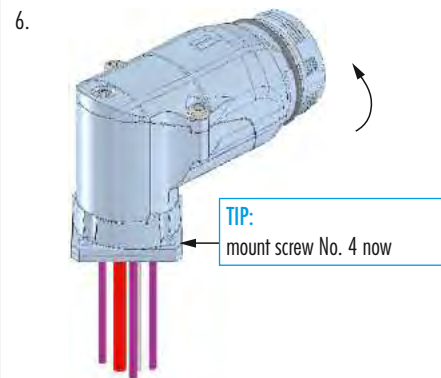
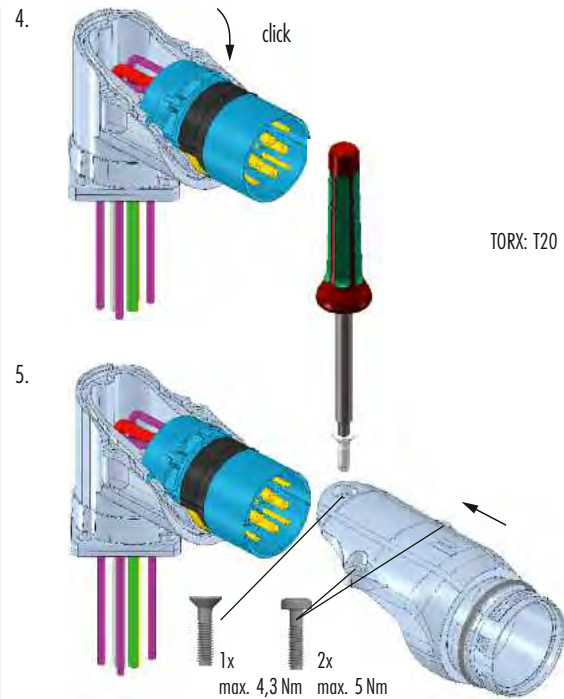
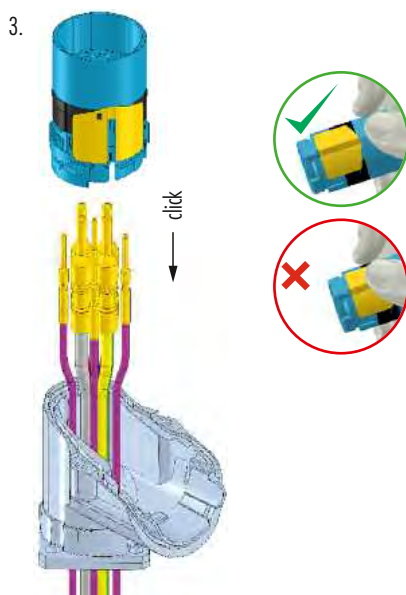
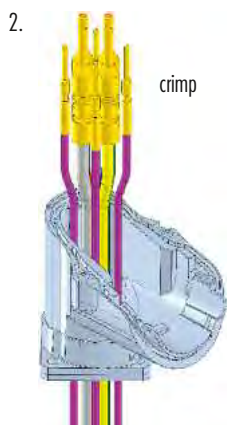
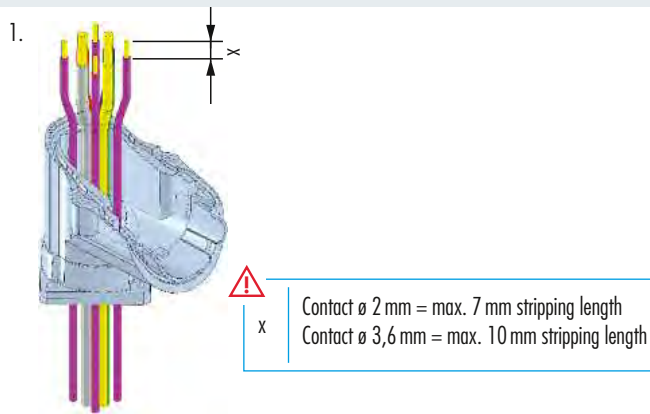



Crimping, Assembly and Disassembly of Contacts

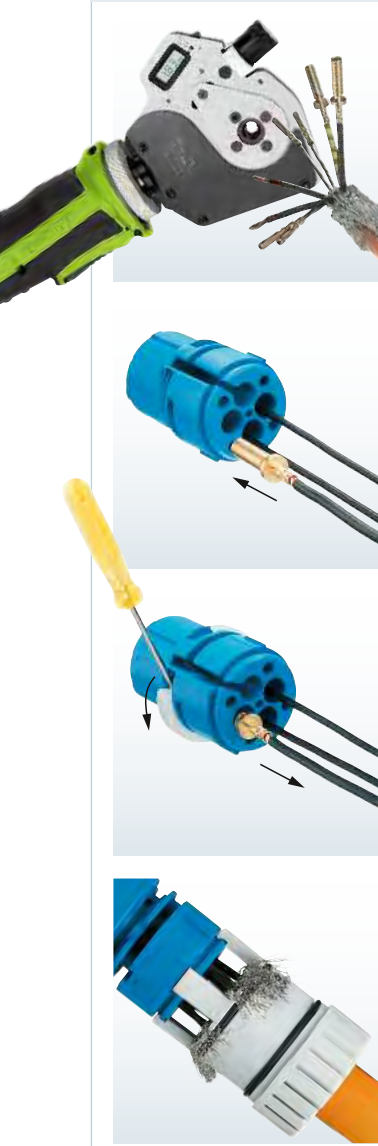

Crimping

- For 2 mm contacts strip wire ends 7 mm (.28"), for 3,6 mm contacts strip wire ends 10 mm (.39")
- // Dial appropriate setting of crimp tool
- // Push crimp contact into opening of crimping tool
- // Insert stripped wire into the funnel shaped end of the crimp contact
- // Squeeze handles of crimping tool together connect contact to wire

Assembly

Remove crimped contact to insert into the ring contact position. Push into desired position of insert.

Disassembly of Contacts from Insert

A small screwdriver is needed to remove the contacts from the insert.

- // Release the white ring by a screwdriver out of the insert
- // Move the misplaced contacts out of the insert
- // Enter the ring back into the insert
- // Push the contacts back into insert

Shielding

- Assemble strain relief insert with insert
- // Fold stranding of the shield back over the first O-Ring of the strain relief insert
- // Cut back the overextending braid



Overstranding of the shield is not allowed to touch the second O-Ring.

STAINLESS STEEL CONNECTORS (INOX)

Special applications require special solutions. This is important for connectors made of stainless steel, too. They are being used where the conditions of the environment are extremely rough or hygienic requirements particularly high.

- // Signal connectors M 16 INOX
- // Signal connectors M 23 INOX
- // Power connectors M 23 INOX



Product overview

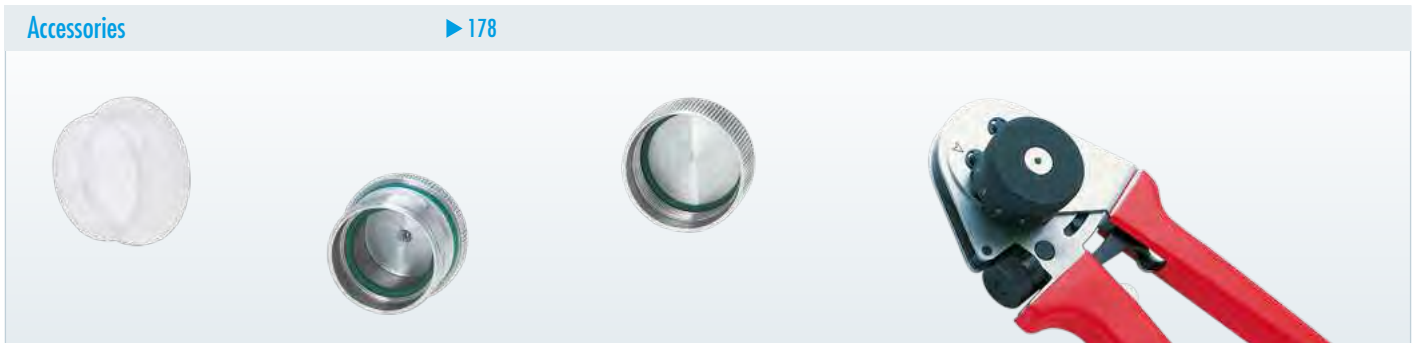
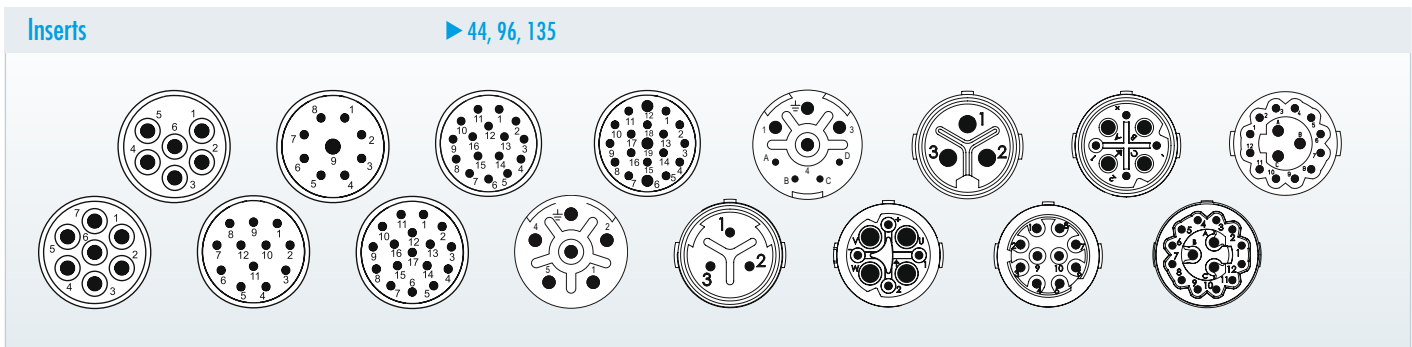

Mechanical Data	Materials and Technical Data	
Housing	Stainless Steel V4A	1.4404 (AISI 316 L)
Housing surface	Clear	
Inserts (for contacts)	Thermoplastic Polyamid PA 6 (Nylon 6/6), PBT	Fire protection class V-0
Contacts	Brass Alloy	
Contact surface at point of contact	Nickel and gold plated (0,25 µm)	
Minimum mating cycles	> 1000	
Seals / O-Rings	Viton® (FPM / FKM), alternativ EPDM	
Temperature range	-40 °C – 125 °C	
Type of contacts signal M 23	Crimp, solder, dip-solder (PCB)	
Type of contacts power M 23	Crimp	
Type of contacts M 16	Crimp, dip-solder (PCB)	
Protection	IP 67 / IP 69K per EN 60 529 (connected), NEMA 4x	

Additional Information			
Electrical data see standard program		Inserts and contacts see standard program	
Connectors M 12 Power	page 21	Connectors M 12 Power	page 25
Connectors M 16	page 39	Connectors M 16	page 44
Signal Connectors M 23	page 87	Signal Connectors M 23	page 96
Power Connectors M 23	page 129	Power Connectors M 23	page 135





Housings M 16

Straight Connector, Female Thread

Cable-Ø	Part Number
3 – 6 mm (.12" – .24")	7.814.300.000
5 – 9 mm (.20" – .35")	7.814.400.000
8 – 11 mm (.31" – .43")	7.814.500.000

▶ 44 |
 ▶ 178 |
 ▶ 57/58

Straight Connector, Male Thread

Cable-Ø	Part Number
3 – 6 mm (.12" – .24")	7.824.300.000
5 – 9 mm (.20" – .35")	7.824.400.000
8 – 11 mm (.31" – .43")	7.824.500.000

▶ 44 |
 ▶ 178 |
 ▶ 57/58

Panel Connector, Male Thread

Type	Part Number
4 x holes Ø 2,7 mm (.11")	7.840.400.000
Flange 20 x 20 mm	

▶ 44 |
 ▶ 178 |
 ▶ 60



Housing without inserts and contacts

Straight Connector, Female Thread

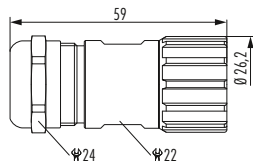

Cable-Ø	Part Number	Part Number EMC
3 – 7 mm (.12 – .28")	7.140.300.000	7.141.300.000
5 – 10 mm (.20 – .39")	7.140.400.000	7.141.400.000
7 – 12 mm (.27 – .47")	7.140.500.000	7.141.500.000
10 – 14 mm (.39 – .55")	7.140.600.000	7.141.600.000

Assembly tool 7.010.900.127 is required



Straight Connector, Male Thread

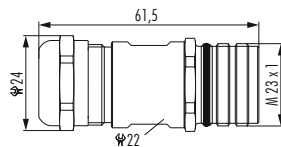

Cable-Ø	Part Number	Part Number EMC
3 – 7 mm (.12 – .28")	7.240.300.000	7.241.300.000
5 – 10 mm (.20 – .39")	7.240.400.000	7.241.400.000
7 – 12 mm (.27 – .47")	7.240.500.000	7.241.500.000
10 – 14 mm (.39 – .55")	7.240.600.000	7.241.600.000



Panel Connector, Male Thread, Single Hole Mounted

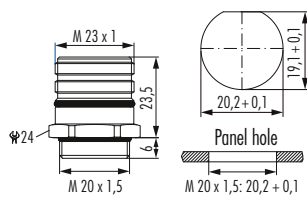

Type	Part Number
Front mounting for male inserts Thread M 20 x 1,5	7.420.400.000

*** FOR MALE *
INSERTS ONLY**



Panel Connector, Male Thread, Single Hole Mounted

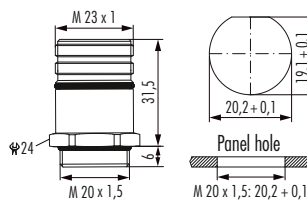

Type	Part Number
Front mounting for female inserts Thread M 20 x 1,5	7.421.400.000



*** FOR FEMALE *
INSERTS ONLY**





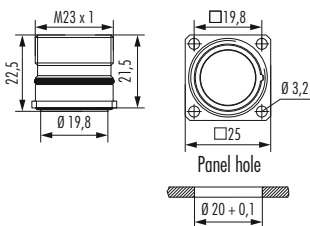

Housing without inserts and contacts



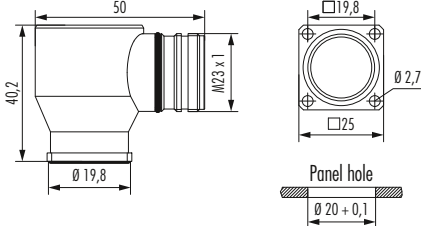

Housings M 23 Signal / Power

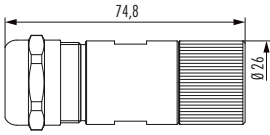
Panel Connector, Male Thread	Type	Part Number
 	With anti-vibration O-Ring 4 holes Ø 3,2 mm (.13").....	7.410.400.000
		

Right Angle Panel Connector, Male Thread	Type	Part Number
 	4 holes Ø 2,7 mm (.11").....	7.430.400.000
		

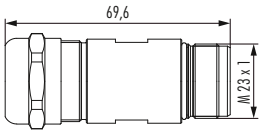
Straight Connector, Female Thread	Type	Part Number
 	7 – 12 mm (.27 – .47")..... 11 – 17 mm (.43 – .67").....	7.554.500.000 7.554.600.000
		

Straight Connector, Male Thread	Type	Part Number
 	7 – 12 mm (.27 – .47")..... 11 – 17 mm (.43 – .67").....	7.564.500.000 7.564.600.000
		

 Housing without inserts and contacts

Panel Connector, Male Thread, Single Hole Mounted

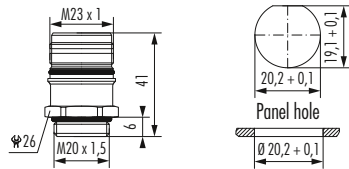

Type

Part Number

Front mounting

Thread M 20 x 1,57.621.400.000



Panel Connector, Male Thread

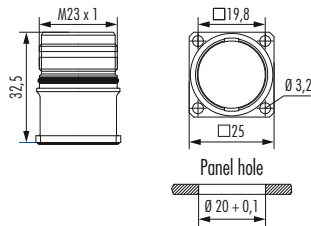

Type

Part Number

For front mounting

4 holes Ø 3,2 mm (.13")7.601.400.000

Optional: Flat gasket



Right Angle Panel Connector, Male Thread

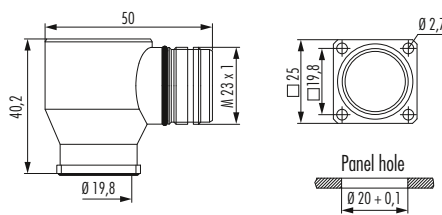

Type

Part Number

4 holes Ø 2,7 mm (.11")7.630.400.000





Accessories

Accessories	Type	Part Number
	Assembly tool	7.010.900.127
	Plastic protective cap	
	for connectors M 16 with male thread	7.000.980.161
	for connectors M 16 with female thread	7.000.980.162
	for connectors M 23 with male thread	7.000.900.101
	for connectors M 23 with female thread	7.000.900.102
	Stainless steel protective cap for M 16 Signal	
	for connectors with female thread	7.010.904.163
	for connectors with male thread	7.010.904.162
	with rope for connectors with female thread, Length 70 mm	7.010.9S4.163
	with rope for connectors with male thread, Length 70 mm	7.010.9S4.162
	Stainless steel protective cap for M 23 Signal	
	for connectors with female thread	7.010.904.103
	with rope for connectors with female thread, Length 100 mm	7.010.9S4.103
	Stainless steel protective cap for M 23 Power	
	for connectors with female thread	7.010.904.183
	with rope for connectors with female thread, Length 100 mm	7.010.9S4.183
	Stainless steel protective cap	
	for connectors with male thread	7.010.904.102
	with rope for connectors with male thread	
	Length 100 mm	7.010.9S4.102
	Crimp tool for manual crimping	
	of machined crimp contacts	
	for signal and power connectors	7.000.900.901
	Crimp tool for manual crimping	
	of machined crimp contacts	
	for signal connectors M 16 and M 23	7.000.900.904



Straight Signal Connector, Female Thread

1. Insert the cable into the connector housing.
2. Strip the outer jacket by 10mm and the insulation by 20mm.
3. Strip the individual conductors.
4. Strip the conductors by 4mm.
5. Strip the conductors by 4mm.
6. Strip the conductors by 4mm.
7. Strip the conductors by 4mm.
8. Insert the conductors into the connector housing.
9. Insert the conductors into the connector housing.
10. Insert the conductors into the connector housing.
11. Tighten the connector housing with a wrench (24mm).
12. Tighten the connector housing with a wrench (22mm).

Additional labels in the diagram include: "click", "code", "7.010.900.127", "crimp", and "4 mm".



Assembly Instructions

Straight Connector, Male Thread

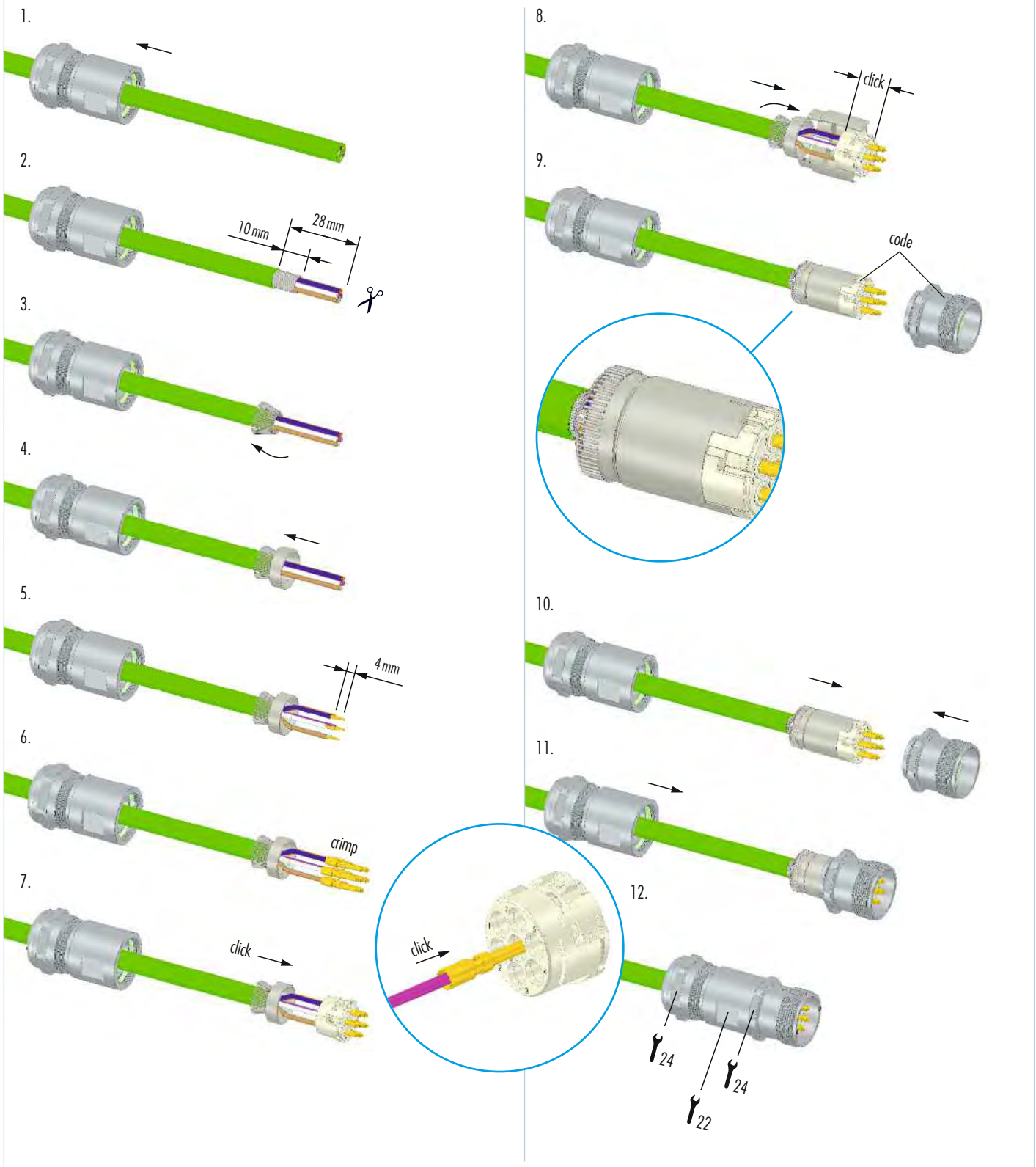

MOULDED CORDSETS

Every connector of the standard series can be sold in a moulded cordset as well. Hereby there is no difference, whether it is one with a male or female thread. Moreover, customized projects are being realised. Cable type and cable length are specified in common technical consultations.

- // Moulded cordset M 16
- // Moulded signal cordset M 23
- // Moulded power cordset M 23



MOULDED CORDSETS

Product overview

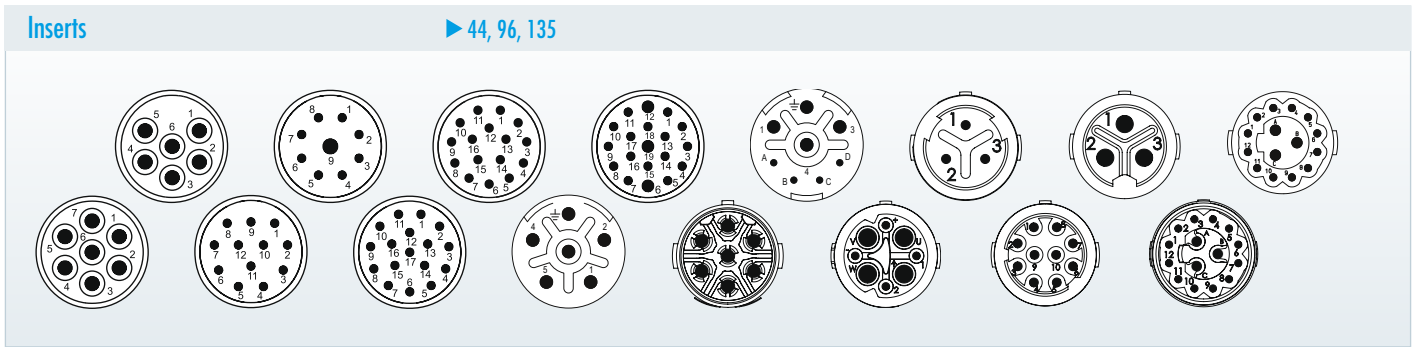

Mechanical Data	Materials and Technical Data
Housing	Copper-Zinc alloy Die Casting
Moulded strain relief	Polyurethan PUR
Housing surface	Nickel plated brass, black strain relief
Inserts (for contacts)	Thermoplastic Polyamid PA 6 (Nylon 6/6), PBT Fire protection class V-0
Contacts	Brass Alloy
Contact surface at point of contact	Nickel and gold plated (0,25 µm)
Seals / O-Rings	Buna-N standard optional Viton® (FPM / FKM) (Viton is a registered trademark of DuPont)
Temperature range	-40 °C – 125 °C (-40 °F – 257 °F)
Type of contacts	Crimp
Protection	IP 67 / IP 69K per EN 60 529 (connected), NEMA 4x
Cable style	Cable specifications available upon request
Labelling	HUMMEL logo as standard, other options available upon request

Additional Information			
Electrical data see standard program		Inserts and contacts see standard program	
Connectors M 12 Power	page 21	Connectors M 12 Power	page 25
Connectors M 16	page 39	Connectors M 16	page 44
Signal Connectors M 23	page 87	Signal Connectors M 23	page 96
Power Connectors M 23	page 129	Power Connectors M 23	page 135

Other versions

Moulded connector cordsets are also available as Stainless-Steel (Inox)-Versions.

MOULDED CORDSETS

Moulded Connector Cordsets M 16

Straight Connector, Female Thread	Type	Inserts
	Standard / EMC	Pins or sockets

Right Angle Connector, Female Thread	Type	Inserts
	Standard / EMC	Pins or sockets

Moulded Signal Connector Cordsets M 23

Straight Connector, Female Thread

Type	Inserts
Standard / EMC	Pins or sockets

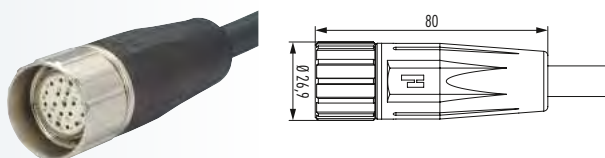

Straight Connector, Male Thread

Type	Inserts
Standard / EMC	Pins or sockets

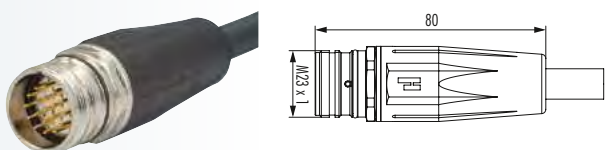

Right Angle Connector, Female Thread

Type	Inserts
Standard / EMC	Pins or sockets

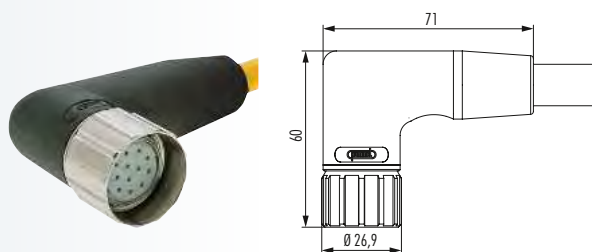

Right Angle Connector, Male Thread

Type	Inserts
Standard / EMC	Pins or sockets

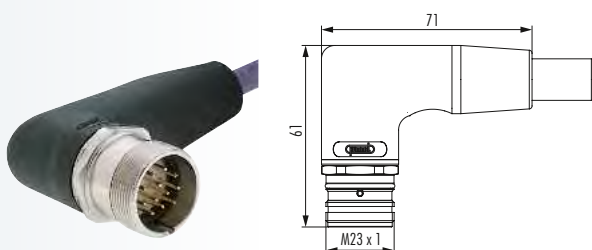

M12

M16

M23 PoE

M23 RJ45

M23 Signal

M27 Signal

M23 Power

M40 Power

INOX

Moulded Cordsets

Customized

MOULDED CORDSETS

Moulded Power Connector Cordsets M 23

Straight Connector, Female Thread	Type	Inserts
	Standard / EMC	Pins or sockets

Straight Connector, Male Thread	Type	Inserts
	Standard / EMC	Pins or sockets

Right Angle Connector, Female Thread	Type	Inserts
	Standard / EMC	Pins or sockets

Right Angle Connector, Male Thread	Type	Inserts
	Standard / EMC	Pins or sockets



Accessories	Type	Part Number
	Plastic protective cap	
	for connectors M 16 with male thread.....	7.000.980.161
	for connectors M 16 with female thread.....	7.000.980.162
	for connectors M 23 with male thread.....	7.000.900.101
	for connectors M 23 with female thread.....	7.000.900.102
	Brass protective cap	
	for connectors M 16 with female thread.....	7.010.900.163 ¹
	for signal connectors M 23 with female thread.....	7.010.900.103 ¹
	for power connectors M 23 with female thread.....	7.010.900.183 ¹
	Brass protective cap	
	for connectors M 16 with male thread.....	7.010.900.162
	for connectors M 23 with male thread.....	7.010.900.102
	Brass protective cap with chain	
	for connectors M 16 with female thread	
	Length 70 mm.....	7.010.950.705 ¹
	for signal connectors M 23 with female thread	
	Length 70 mm.....	7.010.950.703 ¹
	Length 100 mm.....	7.010.951.003 ¹
for power connectors M 23 with female thread		
Length 70 mm.....	7.010.950.783 ¹	
Length 100 mm.....	7.010.951.083 ¹	
	Brass protective cap with chain	
	for connectors M 16 with male thread	
	Length 70 mm.....	7.010.950.704
	for connectors M 23 with male thread	
Length 70 mm.....	7.010.950.702	
Length 100 mm.....	7.010.951.002	

¹ no compatibility with TWILOCK

Customized

Hybrid Connector for Compressed Air



To place lines for compressed air and electrical signals in one single connection, a hybrid connector M 23 combines different types of contacts in one insert.

Bulkhead Connector



Bulkhead connectors accept plugs on both sides. They are rugged, liquid tight and available in all number of poles.

Coloured Overmould



Completing a design or showing technical functions, overmould could be made in different colours too (e.g. DESINA green RAL 6018).

MULTI Seal Connector

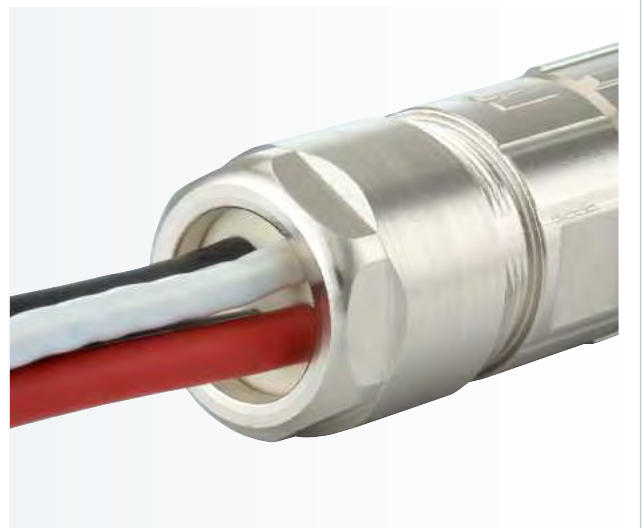

A large selection of standard MULTI seal inserts allow strain relief of several individual conductors on one single connector.

Flexible Cable Protection



In addition to the integrated strain relief, the flex nut adds kink protection to a cable — available for all connector sizes.

Hybrid connector with multi insert



With the multi insert it is possible to set a ethernet and a power cable into one connector. The connection achieves the protection class IP 67.

12-point hex and knurled nut



This special nut makes connection simple by either tightening the connector manually (knurled nut) or with a wrench (12-point hex).

Conduit Attachment



Flexible corrugated conduit can be attached to a connector with an adapter offering strain relief and cable protection as well.

Customized

Connector with specific pull-out resistance



After reaching a certain pull-out force the connection releases preventing damage to the device (apparatus).

Bulkhead Fitting



This fitting with oversized flange is commonly used in the ship building industry where Signal Connections have to be maintained under extreme conditions.

Distribution-box



Distribution-boxes are known as important components for applications in automation. Robust and fully wired they are done according to customers specification.

ANACONDA Conduit Adapter



HUMMEL offers custom adapters for ANACONDA conduit systems in hazardous locations.

Limited Liability

Products, design, colors and dimensions are subject to change without prior notice. We reserve the right to make technical improvements on all our products, currently ordered or for future orders. It is the users responsibility to verify all dimensions and technical data. HUMMEL AG will assume no liability regarding information provided to the user by published literature or inside technical staff, its distributors and outside sales personnel. Errors in the catalog can occur and shall not create any liability whatsoever for HUMMEL AG. All information provided by HUMMEL AG is without guarantee and must be verified by the user.

Imprint

Graphic & Layout:

HUMMEL AG, Marketing & Communications, Lise-Meitner-Str. 2, 79211 Denzlingen, Germany, Tel. +49 (0) 76 66 9 11 10-842, Fax +49 (0) 76 66 9 11 10-20, info@hummel.com

Printer:

Druckerei Furtwängler GmbH, 79211 Denzlingen, Germany, Tel. +49 (0) 76 66 /13 31. Printed on recycled paper in October 2018.

Derating M 12 Power

AWG 16 Straight connectors male + female M 12 Power

K-/L-Coding, wires 4 x AWG 16

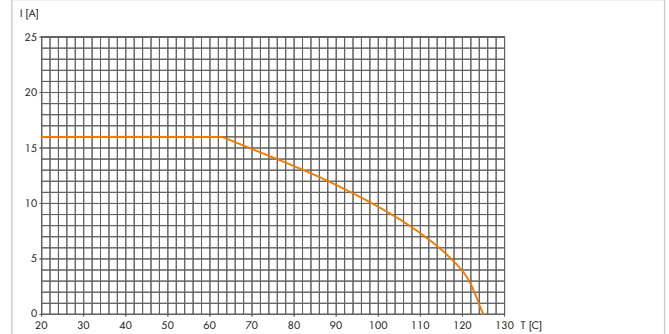

Derating M 12 Power

Straight connectors male + female M 12 Power

S-/T-Coding, wires 4 x AWG 16

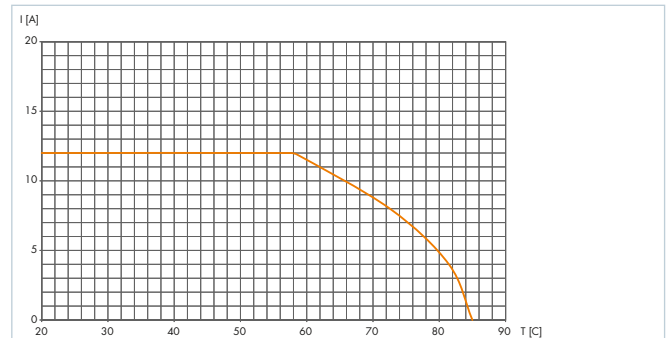

Derating M 16

Straight connectors male + female M 16

10 pole, wires 10 x AWG 18

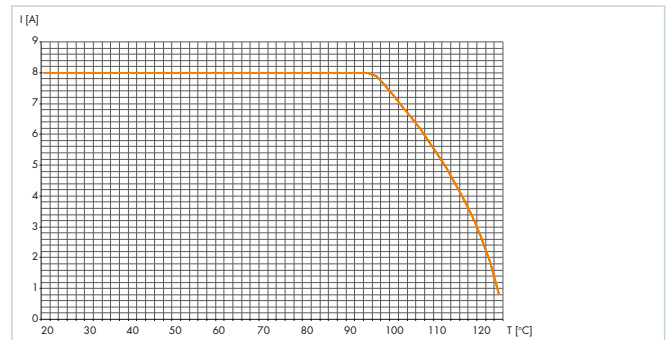

Derating TWINTUS

TWINTUS and straight connector female M 16

4+3+PE, wires AWG 14 (Power)

10 pole, wires AWG 26

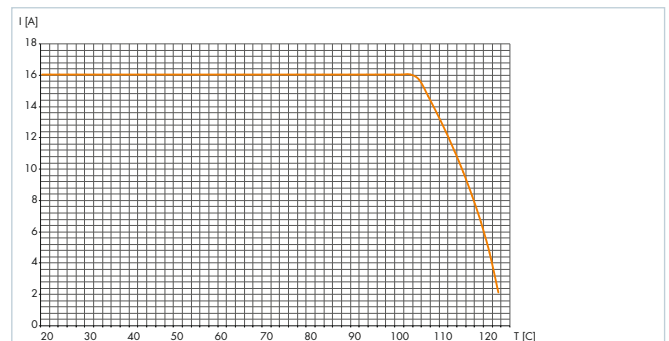

Derating M 23 Signal

Straight Connectors male + female M 23

wires 12 x AWG 17

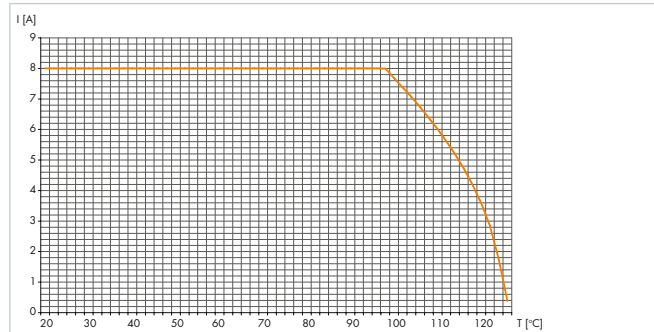

Derating M 23 Power

Straight connectors male + female M 23

3 + PE, wires 3 x AWG 12

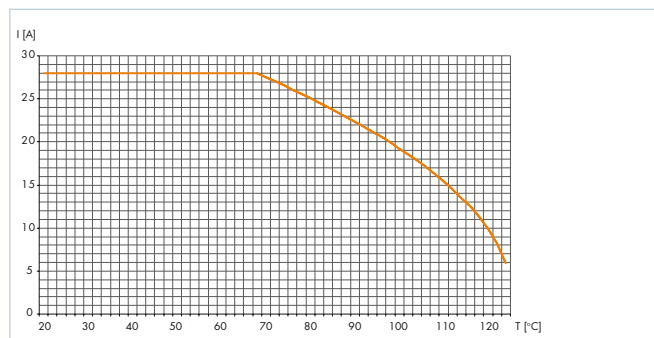

Derating M 40 (Size 1,5)

Straight connectors male + female M 40

wires 3 x AWG 6

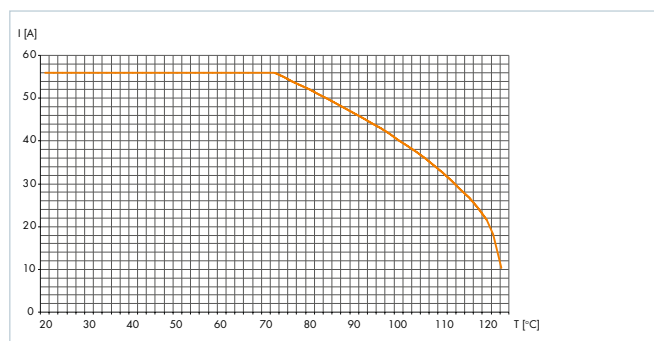







INDEX

Index

Part Number	Page	Part Number	Page	Part Number	Page	Part Number	Page	Part Number	Page
7.000.848.101.....	52	7.003.920.....	68	7.010.982.....	44, 50	7.423.....	91	7.740.0.....	157
7.000.848.102.....	52	7.003.926.....	121	7.010.9S0.702.....	81, 104,	7.425.....	91	7.742.....	159
7.000.900.101.....	69, 81,	7.003.943.....	45	137, 187	7.430.4.....	176	7.744.....	158
.....	104, 137, 178, 187	7.003.961.....	46	7.010.9S0.703.....	104, 187	7.431.....	92	7.749.....	158
7.000.900.102.....	69, 81,	7.003.981.....	97	7.010.9S0.704.....	51, 187	7.435.....	92	7.810.....	40
.....	104, 137, 178, 187	7.003.983.....	44	7.010.9S0.705.....	51, 187	7.439.....	92	7.811.....	40
7.000.900.151.....	161	7.003.985.....	47	7.010.9S0.707.....	123	7.440.....	90	7.814.....	174
7.000.900.152.....	161	7.003.988.....	47	7.010.9S0.708.....	123	7.444.....	90	7.816.....	40
7.000.900.901.....	123,	7.004.912.....	98	7.010.9S0.783.....	69, 81, 137, 187	7.448.....	90	7.820.....	40
.....	137, 140, 178	7.004.917.....	100	7.010.9S1.002.....	69, 81, 137, 187	7.449.....	90	7.824.....	174
7.000.900.903.....	162, 165	7.004.981.....	97	7.010.9S1.003.....	104, 187	7.450.....	93	7.831.....	40
7.000.900.904.....	51, 104, 108, 178	7.010.900.101.....	104	7.010.9S1.083.....	69, 81, 137, 187	7.452.....	93	7.840.0.....	41
7.000.900.906.....	70	7.010.900.102.....	81, 104,	7.010.9S4.102.....	178	7.454.....	93	7.840.1.....	41
.....	70, 108	137, 187	7.010.9S4.103.....	178	7.456.....	93	7.840.2.....	41
7.000.900.907.....	70, 108	7.010.900.103.....	104, 187	7.015.900.102.....	161	7.458.....	93	7.840.4.....	174
7.000.900.908.....	30	7.010.900.110.....	123	7.015.900.103.....	161	7.459.....	93	7.842.....	42
7.000.980.161.....	51,	7.010.900.127.....	178	7.015.9S1.002.....	161	7.460.....	93	7.843.....	42
.....	178, 187	7.010.900.128.....	69, 81, 105, 137	7.015.9S1.003.....	161	7.462.....	93	7.845.....	42
7.000.980.162.....	51,	7.010.900.129.....	161	7.015.95.....	160	7.464.....	93	7.847.....	41
.....	178, 187	7.010.900.135.....	51	7.040.8.....	52	7.466.....	93	7.848.....	43
7.000.980.167.....	123	7.010.900.139.....	69	7.053.9.....	45, 46, 47	7.468.....	67	7.850.....	42
7.000.980.168.....	123	7.010.900.14.....	69	7.084.944.....	135	7.476.....	88	7.852.....	41
7.000.9DM.C03.....	105	7.010.900.151.....	52	7.084.951.....	135	7.486.....	89	7.810.4.....	78
7.000.9DM.C04.....	105	7.010.900.162.....	51, 187	7.105.....	95	7.490.....	94	7.820.4.....	78
7.000.9DM.C06.....	138	7.010.900.163.....	51, 187	7.106.....	88	7.491.....	94	7.840.0.....	78
7.000.9DM.C07.....	138	7.010.900.170.....	123	7.108.....	66, 96, 99, 100	7.492.....	94	7.841.0.....	78
7.001.903.....	44	7.010.900.183.....	69, 81, 137, 187	7.110.....	120	7.492.....	94	7.842.0.....	79
7.001.906.....	96	7.010.900.190.....	30, 52,	7.140.....	175	7.550.....	130	7.842.0.....	79
7.001.907.....	96	82, 105, 138	7.141.....	175	7.554.....	176	7.843.0.....	79
7.001.908.....	45	7.010.900.191.....	30, 52	7.166.....	88	7.556.....	130	7.845.0.....	79
7.001.910.....	46	7.010.900.192.....	82, 105	7.206.....	88	7.560.....	130	7.847.4.....	80
7.001.912.....	98	7.010.900.200.....	52	7.208.....	66	7.564.....	176	7.850.0.....	79
7.001.916.....	99	7.010.900.202.....	52	7.210.....	120	7.566.....	130	7.852.4.....	80
7.001.917.....	99	7.010.900.205.....	69, 81, 105, 138	7.240.....	175	7.576.....	131	7.701.....	95
7.001.919.....	100	7.010.900.207.....	69, 81, 105, 138	7.241.....	175	7.580.....	131	7.702.....	95
7.001.920.....	68	7.010.900.209.....	69, 81, 105, 138	7.300.....	89	7.601.0.....	132	A712-7.000.....	30
7.001.926.....	121	7.010.900.215.....	162	7.301.....	89	7.601.4.....	177	A712-7.001.908.....	48
7.001.928.....	121	7.010.900.217.....	162	7.306.....	89	7.605.....	132	A712-7.001.912.....	48
7.001.943.....	45	7.010.901.001.....	44, 49, 102	7.308.....	66	7.621.0.....	133	A712-7.010.900.....	30
7.001.961.....	46	7.010.901.002.....	44, 49, 68, 102	7.400.....	90	7.621.4.....	177	A712-7.010.901.....	26
7.001.981.....	97	7.010.901.012.....	44, 49, 68, 102	7.402.....	90	7.623.....	133	A712-7.010.911.....	26
7.001.983.....	44	7.010.901.021.....	102	7.404.....	90	7.626.....	133	A712-7.010.9S0.....	30
7.001.985.....	47	7.010.901.022.....	68, 102	7.406.....	90	7.630.4.....	177	A712-7.K03.....	25
7.001.988.....	47	7.010.901.031.....	102	7.408.....	66	7.635.....	134	A712-7.K10.....	22
7.002.912.....	98	7.010.901.5.....	104	7.410.0.....	90	7.636.....	134	A712-7.K20.....	22
7.002.917.....	100	7.010.902.001.....	103	7.410.4.....	176	7.639.....	134	A712-7.K30.....	22
7.002.981.....	97	7.010.902.002.....	103	7.410.7.....	120	7.641.....	132	A712-7.K31.....	22
7.003.903.....	44	7.010.904.102.....	178	7.412.....	90	7.645.....	132	A712-7.K40.....	24
7.003.906.....	96	7.010.904.103.....	178	7.414.....	90	7.651.....	133	A712-7.K42.0.....	23
7.003.907.....	96	7.010.908.102.....	69	7.416.....	90	7.653.....	131	A712-7.K42.1.....	23
7.003.908.....	45	7.010.94.....	136	7.420.0.....	91	7.661.....	132	A712-7.K42.2.....	24
7.003.910.....	46	7.010.971.....	122	7.420.4.....	175	7.681.....	131	A712-7.K44.0.....	23
7.003.912.....	98	7.010.980.6.....	68, 136	7.421.0.....	91	7.683.....	130	A712-7.K44.1.....	23
7.003.916.....	99	7.010.980.8.....	45, 47, 49	7.421.4.....	175	7.710.....	156	A712-7.K44.2.....	24
7.003.917.....	99	7.010.981.....	45, 46, 47, 49, 50	7.422.....	91	7.716.....	156	A712-7.K50.....	23
7.003.919.....	100					7.720.....	157	A712-7.K51.....	23

Part Number	Page
A712-7.L03	25
A712-7.S10	22
A712-7.S20	22
A712-7.S30	22
A712-7.S31	22
A712-7.S40	24
A712-7.S42.0	23
A712-7.S42.2	24
A712-7.S44.0	23
A712-7.S44.2	24
A712-7.S50	23
A712-7.S51	23
A712-7.S05	25
A712-7.T05	25
A712-K	27, 28, 29
A712-L	27, 28, 29
A712-S	27, 28, 29
A712-T	27, 28, 29
A7RJ-081M41	82
A7RJ-821M51	82

Europe

HUMMEL France

HUMMEL s.a.r.l.
4, rue des fleurs
68190 Ungersheim / France

Tel. +33 (0) 3 89 / 55 37 20
Fax +33 (0) 3 89 / 53 80 27
E-Mail info.fr@hummel.com
www.hummel.com

HUMMEL UK

HUMMEL UK Limited
Office 3, Momentum House
Enterprise Way, Lowton St Marys,
Warrington, Cheshire, WA3 2BP
United Kingdom

Tel. +44 (0) 19 42 / 60 56 95
Fax +44 (0) 19 42 / 26 93 24
E-Mail info.uk@hummel.com
www.hummel.com

HUMMEL Italy

HUMMEL S.r.l.
Via Enrico Fermi 61
10091 Alpignano (Torino) / Italy

Tel. +39 (0) 11 / 9 68 26 38
Fax +39 (0) 11 / 9 78 55 50
E-Mail info.it@hummel.com
www.hummel.com

HUMMEL Austria

HUMMEL Sales Office Austria

Tel. +43 (0) 6 64 / 2 52 31 32
E-Mail info.at@hummel.com
www.hummel.com

HUMMEL Poland

HUMMEL Sales Office Poland
Al. 23 Strycznia 26 lok. 20
86-300 Grudziadz / Poland

Tel. +48 (0) 6 62 / 38 27 99
Fax +48 (0) 56 / 6 43 00 11
E-Mail info.pl@hummel.com
www.hummel.com

HUMMEL Russia

OOO HUMMEL
Ul. Retschnikow 21, Strojenije 1
115142 Moskau / Russia

Tel. +7 (0) 4 99 / 7 82 40 68
Fax +7 (0) 4 99 / 6 14 67 40
E-Mail info.ru@hummel.com
www.hummel-russia.ru

HUMMEL Scandinavia

HUMMEL Connector Systems AB

Tel. +46 (0) 73 / 8 00 12 00
E-Mail info.se@hummel.com
www.hummel.com

Asia

HUMMEL China

HUMMEL Connector Systems (Shanghai) Co., Ltd.
Room 1701 Central Plaza
No.227 Huang Pi (N) Road
200003 Shanghai / P.R. China

Tel. +86 (0) 21 / 63 75 85 51
Fax +86 (0) 21 / 63 75 85 53
E-Mail info.hcs.cn@hummel.com
www.hummel.com

HUMMEL India

HUMMEL Connector Systems Pvt. Ltd.
1211, Surya Kiran Building, 19,
Kasturba Gandhi Marg
110001 New Delhi/India

Tel. +91 (0) 11 / 43 00 75-21 / -23
Fax +91 (0) 11 / 43 00 75-22
E-Mail info.in@hummel.com
www.hummel.com

HUMMEL South Korea

HUMMEL AG KOREA Co., Ltd.
#628 Ssangyong Platinum River
659, Olympic-ro, Gangdong-gu
Seoul 05248 / Korea

Tel. +82 (0) 2 / 4 70 27 62
Fax +82 (0) 2 / 4 70 27 63
E-Mail info.kr@hummel.com
www.hummel.com

South America

HUMMEL Brazil

HUMMEL Connector Systems Ltda.
Rua Derville Gabriel Pereira, 280,
Barro Preto — Centro Empresarial Tatuí I
CEP 18280-614 — Tatuí / SP / Brazil

Tel. +55 (0) 15 / 33 22 70 00
Fax +55 (0) 15 / 33 22 70 26
E-Mail vendas@hummel.com.br
www.hummel.com.br

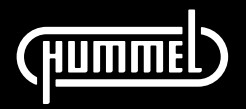

HUMMEL INTERNATIONAL



ELECTRIC COMPONENTS

Cable Glands

Polyamide-, Brass- and Stainless steel,
EMC-connections, Protection Ex e, Ex d, Ex ta



Circular Connectors

M 8 to M 40, INOX, TWILOCK, Industrial Ethernet,
Power, Signal, Hybrid-Connector, Moulded Cordsets



Conduit Systems

Corrugated Conduit Systems, Conduit Cable Glands, Angled Systems,
combined Cable Glands, Accessories



Cable Assembly

Moulded Signal- and Power Circular Connectors,
Servo Cables, Cable Sets



www.hummel.com



HUMMEL AG
Lise-Meitner-Straße 2
79211 Denzlingen
Germany
www.hummel.com

Tel. +49 (0) 76 66 / 9 11 10-0
Fax +49 (0) 76 66 / 9 11 10-20
E-Mail info@hummel.com

