

High Performance

Flanged Safety Relief Valves

Series 441

Series XXL

Series 444



CATALOG 1

LESER

The-Safety-Valve.com

LESER Safety Valves for every industrial application



High Performance



Compact Performance

Series 441

Type 441, 442 DIN
Type 441, 442 ANSI



API

Series XXL

Type 441, 442 XXL



Clean Service

Series 444

Type 444 DIN
Type 444 ANSI

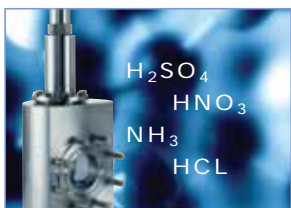

Critical Service

Series 441 Full nozzle

Type 441, 442 Full nozzle DIN
Type 441, 442 Full nozzle ANSI



Modulate Action



Best Availability

Series 458

Type 455, 456
Type 457, 458

Please refer to High Performance Catalog 2

General

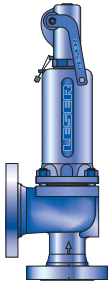

Type 441, 442 DIN

DN 20, 40, 50
Set pressure 0,1 – 40 bar, 1,5 – 580 psig
Flanges according to DIN EN 1092

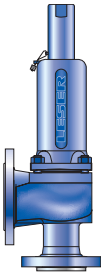

Type 441, 442 ANSI

Valve size 1" – 4"
Set pressure 0,1 – 51 bar, 1,5 – 740 psig
Flanges according to ASME B16.5

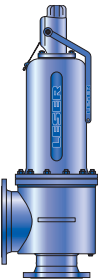

Type 441, 442 XXL

DN 25 – 100, 1" – 4"
Set pressure 0,2 – 25 bar, 3 – 360 psig
Flanges according to DIN EN 1092 and ASME B16.5



Type 444 DIN

DN 25 – 80
Set pressure 0,1 – 16 bar, 1,5 – 232 psig
Flanges according to DIN EN 1092



Type 444 ANSI

Valve size 1" – 3"
Set pressure 0,1 – 16 bar, 1,5 – 232 psig
Flanges according to ASME B16.5



Options

Overview

Chapter/Page

General	00/01
Applications, General design features	00/02
Valve finder	00/03
Valve selection	00/05
How to use: Signs and symbols, Flange drillings and facings	00/07
How to use: Determination of coefficient of discharge K_{dr} / α_w	00/08
How to use: Capacity sheets	00/09
LESER Effective Orifice $LEO_{S/G}$	00/11
LESER Effective Orifice LEO_L	00/12
Sour gas service	00/13

Type 441, 442 ANSI

02/01

Materials	
• Conventional design	02/02
• Balanced bellows design	02/04
How to order	
• Numbering system	02/06
• Article numbers	02/08
Dimensions and weights	
• Metric Units	02/10
• US Units	02/11
Pressure temperature ratings	
• Metric Units	02/12
• US Units	02/13
Flange drillings and facings	02/14
Order information – Spare parts	02/15
Available options	02/16
Approvals	02/17
Capacities	
• Steam [Metric Units + US Units]	02/18
• Air [Metric Units + US Units]	02/19
• Water [Metric Units + US Units]	02/20
Determination of coefficient of discharge K_{dr} / α_w	02/21

LESER Type

Chapter/Page

Type 441, 442 DIN	01/01
Materials	
• Conventional design	01/02
• Balanced bellows design	01/04
How to order	
• Numbering system	01/06
• Article numbers	01/08
Dimensions and weights	
• Metric Units	01/10
• US Units	01/11
Pressure temperature ratings	
• Metric Units	01/12
• US Units	01/14
Flange drillings and facings	01/16
Order information – Spare parts	01/18
Available options	01/20
Approvals	01/21
Capacities	
• Steam [Metric Units + US Units]	01/22
• Air [Metric Units + US Units]	01/24
• Water [Metric Units + US Units]	01/26
Determination of coefficient of discharge K_{dr} / α_w	01/28

Type 441, 442 XXL

03/01

Materials	
• Conventional design	03/02
• Balanced bellows design	03/04
How to order	
• Numbering system	03/06
• Article numbers	03/08
Dimensions and weights	
• Metric Units	03/10
• US Units	03/11
Pressure temperature ratings	
• Metric Units	03/12
• US Units	03/13
Flange drillings and facings	03/14
Order information – Spare parts	03/15
Available options	03/16
Approvals	03/17
Capacities	
• Steam [Metric Units + US Units]	03/18
• Air [Metric Units + US Units]	03/19
• Water [Metric Units + US Units]	03/20
Determination of coefficient of discharge K_{dr} / α_w	03/21

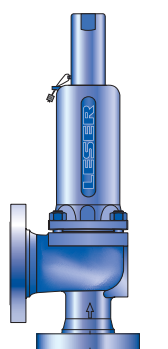

Type 441
Cap H2
Closed bonnet
Conventional design

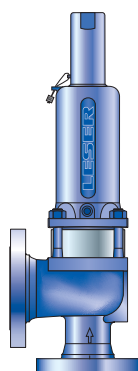

Type 441
Cap H2
Closed bonnet
Balanced bellows design

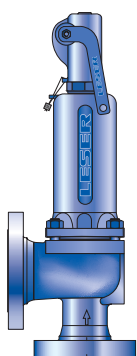

Type 441
Packed lever H4
Closed bonnet
Conventional design

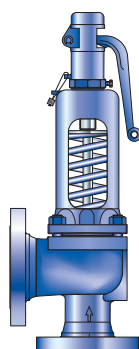

Type 442
Plain lever H3
Open bonnet
Conventional design

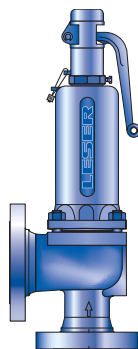

Type 441
Plain lever H3
Closed bonnet
Conventional design

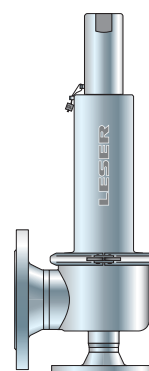

Type 444
Cap H2
Closed bonnet
Conventional design

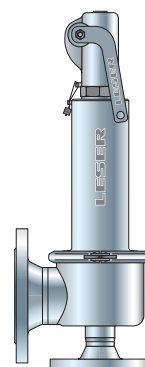

Type 444
Packed lever H4
Closed bonnet
Conventional design

Type 444 DIN	04/01
Materials	
• Conventional design	04/02
How to order	
• Numbering system	04/04
• Article numbers	04/06
Dimensions and weights	
• Metric Units + US Units	04/07
Pressure temperature ratings	
• Metric Units + US Units	04/08
Flange drillings and facings	04/09
Order information – Spare parts	04/10
Available options	04/11
Approvals	04/12
Capacities	
• Steam [Metric Units + US Units]	04/13
• Air [Metric Units + US Units]	04/14
• Water [Metric Units + US Units]	04/15
Determination of coefficient of discharge K_{dr} / α_w	04/16

Type 444 ANSI	05/01
Materials	
• Conventional design	05/02
How to order	
• Numbering system	05/04
• Article numbers	05/06
Dimensions and weights	
• Metric Units + US Units	05/07
Pressure temperature ratings	
• Metric Units + US Units	05/08
Flange drillings and facings	05/09
Order information – Spare parts	05/10
Available options	05/11
Approvals	05/12
Capacities	
• Steam [Metric Units + US Units]	05/13
• Air [Metric Units + US Units]	05/14
• Water [Metric Units + US Units]	05/15
Determination of coefficient of discharge K_{dr} / α_w	05/16

Options	99/01
Overview	99/02
Caps and Levers	99/04
Caps and Levers bolted	99/06
Metal seat	99/08
Soft seal disc	99/10

Options	
Soft seal	99/12
Balanced bellows	99/14
High temperature equipment	99/16
Elastomer bellows	99/17
Disc	99/18
Heating jacket	99/20
O-ring damper	99/22
Lift indicator	99/24
Lift restriction	99/25
First in safety	
Information tools	

Type 441, 442 Full nozzle	
Materials	
How to order	
Dimensions and weights	
Pressure temperature ratings	
Flange drillings and facings	
Order information – Spare parts	
Available options	
Approvals	
Capacities	
Determination of coefficient of discharge K_{dr} / α_w	

refer to catalog
Series 441 Full nozzle

Type 455, 456	
Materials	
How to order	
Dimensions and weights	
Pressure temperature ratings	
Flange drillings and facings	
Order information – Spare parts	
Available options	
Approvals	
Capacities	
Determination of coefficient of discharge K_{dr} / α_w	

refer to catalog
Series 458

Type 457, 458	
Materials	
How to order	
Dimensions and weights	
Pressure temperature ratings	
Flange drillings and facings	
Order information – Spare parts	
Available options	
Approvals	
Capacities	
Determination of coefficient of discharge K_{dr} / α_w	

refer to catalog
Series 458

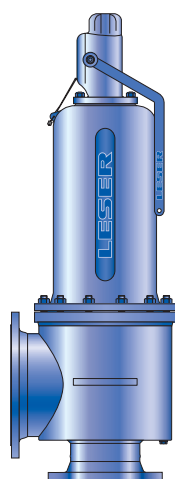

Type 441 XXL
Bolted lifting device H6
Closed bonnet
Conventional and balanced bellows design

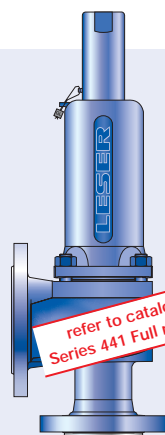

Type 441 Full Nozzle
Cap H2
Closed bonnet
Conventional design

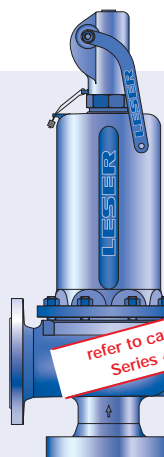

Type 456
Packed lever H4
Closed bonnet
Conventional design

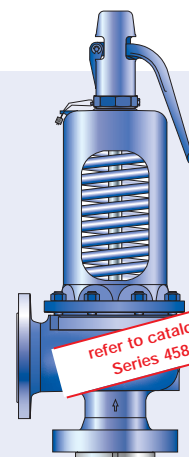

Type 457
Plain lever H3
Open bonnet
Conventional design

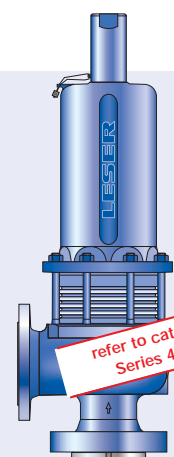

Type 458
Cap H2
Closed bonnet
Balanced bellows design



LESER – High Performance Safety Valves

The High Performance product group represents

- ✓ High capacity related to the safety valve size
- ✓ High adaptability
- ✓ Excellent price / performance ratio

LESER's High Performance Safety Valves

- Are designed to meet all industrial applications.
- Open rapidly with an overpressure of 5 % to the full design lift.
- Are used particularly for vapours and gases where the maximum mass flow has to be discharged rapidly.
- Have a maximum blowdown of minus 10 % for steam/gas service and minus 20 % for liquid service.
- Are one of the best selling spring loaded safety valve worldwide.
- Are developed in a close cooperation with plant engineers and service specialists.
- Serve for protection of processes and equipment.
- Are approved by all important approval organisations worldwide which ensures the worldwide applicability e.g.:
 - European Community: CE-marking acc. to Pressure Equipment Directive (PED) 97 / 23 / EC and EN ISO 4126-1
 - USA: UV-stamp acc. to ASME Section VIII Division 1, National Board certified capacities
 - Germany: VdTÜV approval acc. to PED, EN ISO 4126-1, TÜV SV 100 and AD 2000-Merkblatt A2
 - Canada: Canadian Registration Number acc. to the requirements of particular provinces
 - China: AOSIQ based on the approval acc. to ASME Section VIII Division 1 and AD 2000-Merkblatt A2

Furthermore, all LESER High Performance safety valves are designed, marked, produced and approved acc. to the requirements of the following regulations (directives, codes, rules and standards).

EN ISO 4126-7, EN 12266-1/-2, EN 1092 Part I and II flanging
 ASME PTC 25, ASME-Code Sec. II, ASME B 16.34 and ASME B16.5- flanging, API Std. 527, API RP 576
 AD 2000-Merkblatt A4, AD 2000-Merkblatt HP0, TRD 110, TRD 421, TRD 721



Applications

LESER – High Performance Safety Valves

Are the ultimate solution for all industrial applications for steam, gas and liquid.

Typical applications for LESER High Performance Safety Valves are:

Series 441

- Protection of chemical processes and equipment (e.g. distillation columns)
- Heat exchangers
- Low and medium pressure steam
- Blowers and turbo compressors

Series XXL

- Low pressure steam at big power stations
- Capacities beyond the limits of API and Series 441

Series 444

- OEM in dying machines or filter constructions
- Stainless steel applications up to 16 bar / 232 psig

Series 441 Full Nozzle

- Same applications like Series 441 when full nozzle design is preferred.
- Special requirement for nozzle material

Series 458

- Power stations and industrial superheated steam generation
- Required flange classes \geq PN 63 / CL600
- Protection of high pressure Chemical processes, e.g. NH₃ synthesis, CO₂ extraction
- Desalination plants

General Design Features

LESER's High Performance Safety Valves

Offer a large variety of types, materials and options to suit any application:

- 14 valve sizes from DN 20 to DN 400 – $\frac{3}{4}$ " to 16" provide a high connectivity to the application
- Inlet pressure ratings PN 16 to PN 400 / class 150 to class 2500 to fit all required design pressures
- Orifice sizes from E to $> 3 \times T$ cover all capacity requirements
- Large variety of body materials; e.g.

- 0.6025 / grey iron
- 0.7043 / ductile iron
- 1.0619 / WCB
- 1.4408 / CF8M
- 1.7357 / WC6

can be selected acc. to the application

- Set pressures from 0,1 to 300 bar / 1,5 to 4350 psig make this product group suitable for all industrial processes
- Operating temperatures from -270 to 550 °C / -454 to 1022 °F cover a wide range of applications
- One design and spring (single trim) for steam, gas and liquid applications reduces the number of spare parts and ensure an easier maintenance
- High capacity compared to the API requirements to reduce installation costs
- Ringless design needs no trim adjustments for easy maintenance
- One-piece spindle reduces friction which is leading to high operation accuracy
- Self-draining body design, avoids residues and reduces corrosion

LESER's High Performance Safety Valves

can be customized with a great variety of options, e.g.

- O-ring disc for superior tightness
- Stellite or hardened metal sealing for longer product life
- Stainless steel bellows for back pressure compensation
- Heating jacket for applications with high viscosity fluids
- Every part can be replaced by other material acc. to customer specification

Valve finder

How to find the right Product Group

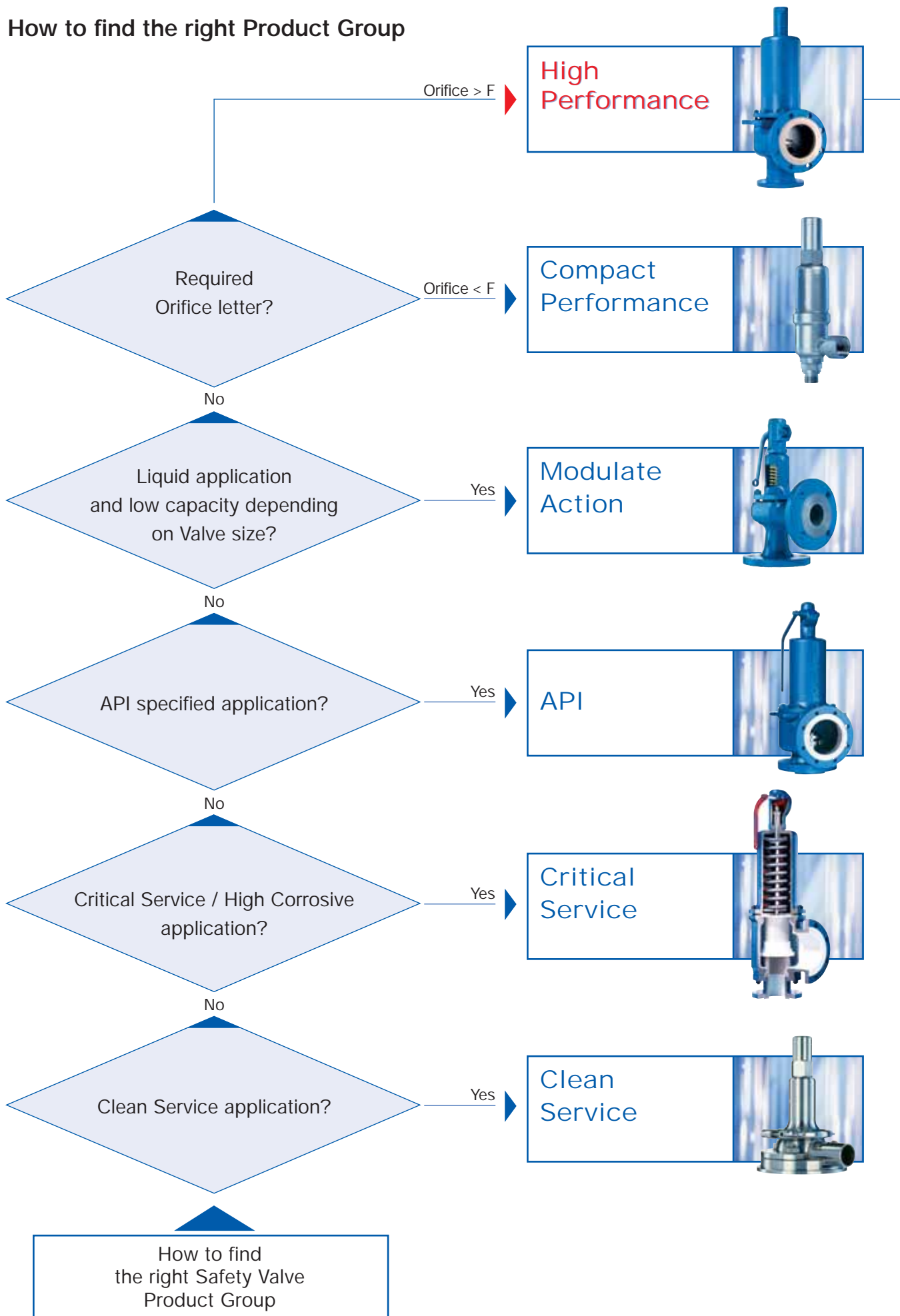

How to find the right Safety Valve

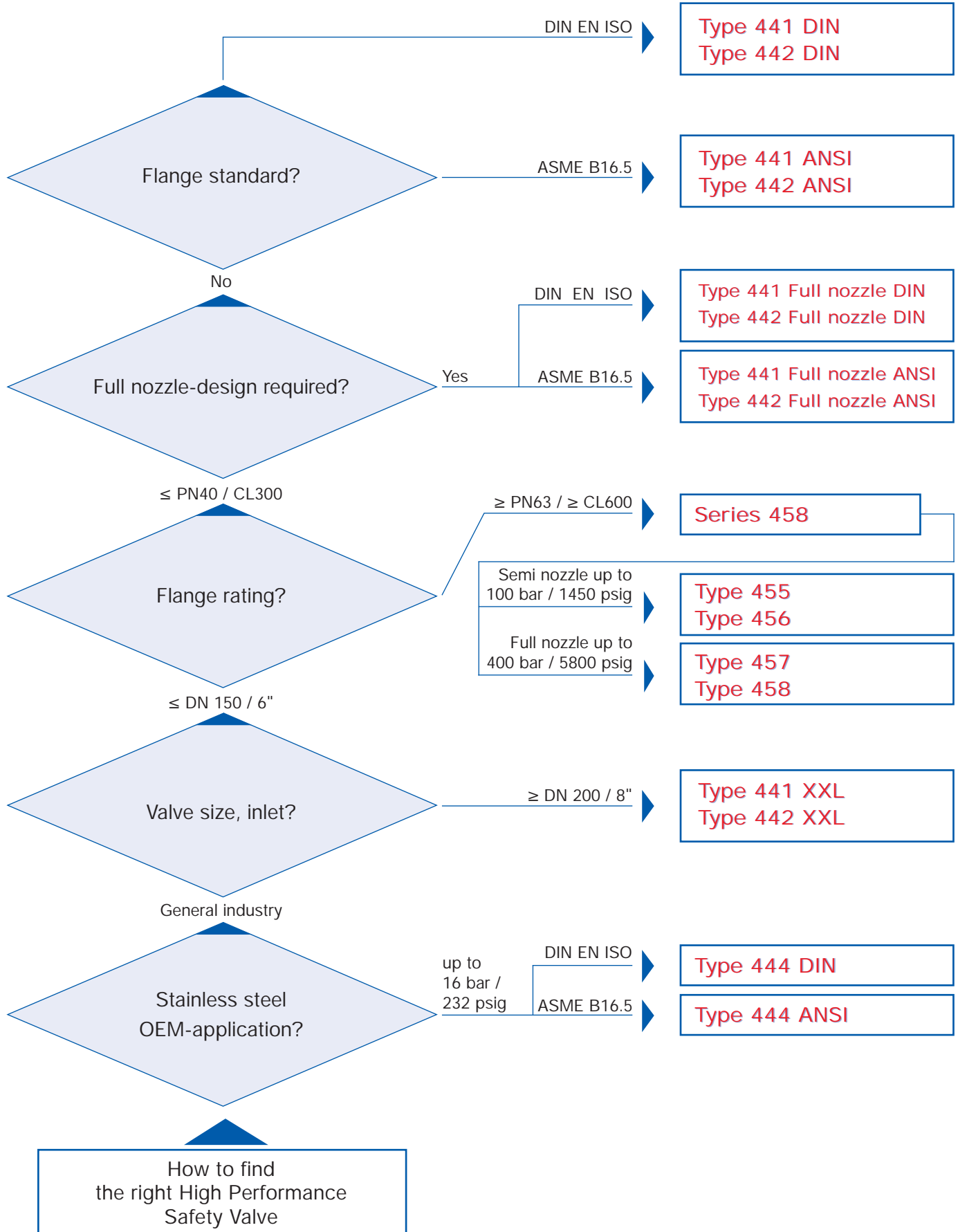

Valve selection

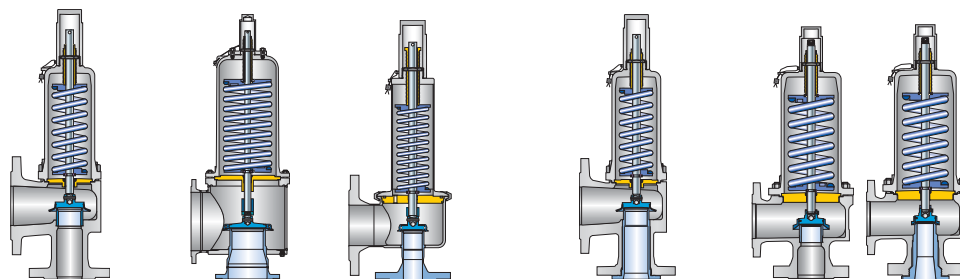

Valve size		Type	441, 442 DIN	441, 442 ANSI	441, 442 XXL	444 DIN	444 ANSI	441, 442 Full nozzle DIN	441, 442 Full nozzle ANSI	455, 456	457, 587
min.			DN 20 (¾")	(DN 25) 1"	DN 200 8"	DN 25 –	– 1"	DN 25 (1")	(DN 25) 1"	DN 25 1"	DN 25 1"
max.			DN 200 (8")	(DN 100) 4"	DN 400 16"	DN 80 –	– 3"	DN 50 (2")	(DN 100) 4"	DN 100 4"	DN 150 6"

Materials		Type	441, 442 DIN	441, 442 ANSI	441, 442 XXL	444 DIN	444 ANSI	441, 442 Full nozzle DIN	441, 442 Full nozzle ANSI	455, 456	457, 587
0.6025	Grey iron		✓	–	–	–	–	–	–	–	–
0.7043	Ductile Gr. 60-40-18		✓	–	–	–	–	–	–	–	–
1.0619	WCB		✓	✓	–	–	–	✓	✓	✓	✓
1.0460 / 1.0425	Carbon steel		–	–	✓	–	–	–	–	–	–
1.4408	CF8M		✓	✓	–	–	–	✓	✓	–	–
1.4404	316L		–	–	–	✓	✓	–	–	–	–
1.4581	CF10M		–	–	–	–	–	–	–	✓	✓
1.4571	316Ti		–	–	✓	–	–	–	–	–	–
1.7357	WC6		–	–	–	–	–	–	–	✓	✓

Set pressure		Type	441, 442 DIN	441, 442 ANSI	441, 442 XXL	444 DIN	444 ANSI	441, 442 Full nozzle DIN	441, 442 Full nozzle ANSI	455, 456	457, 458
Metric Units	min. [bar]		0,1	0,1	0,2	0,1	0,1	0,1	0,1	2,5	2,5
US Units	min. [psig]		1,5	3	3	1,5	1,5	1,5	1,5	36	36
Metric Units	max. [bar]		40	51	25	16	16	40	51	100	300
US Units	max. [psig]		580	740	360	232	232	580	740	1450	4350

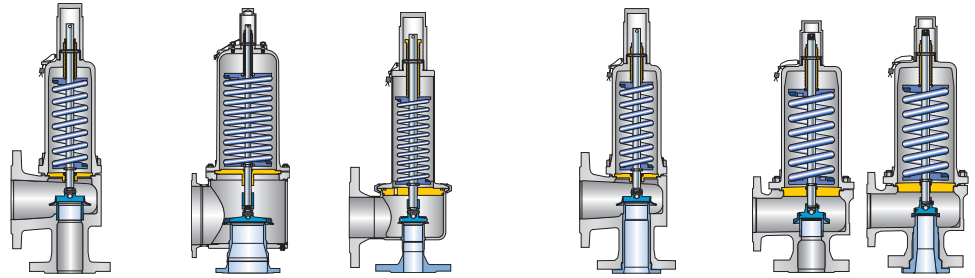

Temperature range

Type		441, 442 DIN	441, 442 ANSI	441, 442 XXL	444 DIN	444 ANSI	441, 442 Full nozzle DIN	441, 442 Full nozzle ANSI	455, 456	457, 458
acc. to DIN EN	min. [°C]	-270	-270	-196	-45	-45	-270	-270	-85	-270
	max. [°C]	450	450	550	200	200	450	450	550	550
	min. [°F]	-454	-454	-321	-49	-49	-454	-454	-121	-454
	max. [°F]	842	842	1022	392	392	842	842	1022	1022
acc. to ASME	min. [°C]	-268	-268	-184	-45	-45	-268	-268	-129	-268
	max. [°C]	538	538	427	200	200	538	538	538	538
	min. [°F]	-450	-450	-300	-49	-49	-450	-450	-20	-450
	max. [°F]	1000	1000	800	392	392	1000	1000	1000	1000

Capacity

Type		441, 442 DIN	441, 442 ANSI	441, 442 XXL	444 DIN	444 ANSI	441, 442 Full nozzle DIN	441, 442 Full nozzle ANSI	455, 456	457, 458
LEO _{S/G}	min.	0,283	0,462	23,8	0,462	0,462	0,462	0,462	0,399	0,224
LEO _{S/G}	max.	23,8	7,39	76,0	4,78	4,78	1,85	7,39	5,46	11,4
Orifice _{S/G}	min.	1,4 x E	1,5 x F	1,5 x R	1,5 x F	1,5 x F	1,5 x F	1,5 x F	1,3 x F	1,1 x E
Orifice _{S/G}	max.	1,5 x R	1,2 x P	3,0 x T	1,1 x N	1,1 x N	1,0 x K	1,2 x P	1,3 x N	1,0 x Q
LEO _L	min.	0,316	0,516	26,6	0,516	0,516	0,516	0,516	0,429	0,241
LEO _L	max.	26,6	8,26	84,9	5,34	5,34	2,07	8,26	5,87	10,9
Orifice _L	min.	1,0 x F	1,0 x G	1,0 x T	1,0 x G	1,0 x G	1,0 x G	1,0 x G	1,4 x F	1,2 x E
Orifice _L	max.	1,0 x T	1,3 x P	33 x T	1,2 x N	1,2 x N	1,1 x K	1,3 x P	1,4 x N	1,7 x P

Approvals

Type			441, 442 DIN	441, 442 ANSI	441, 442 XXL	444 DIN	444 ANSI	441, 442 Full nozzle DIN	441, 442 Full nozzle ANSI	455, 456	457, 587
Country	Code	Media									
Europe	DIN EN ISO 4126-1 CE-marking	S/G/L	072020111Z 0008/0/08-2	072020111Z 0008/0/08-2	072020111Z 0008/0/08-2	072020111Z 0008/0/08-2	072020111Z 0008/0/08-2	072020111Z 0008/0/08-2	072020111Z 0008/0/08-2	072020111Z 0008/0/11	072020111Z 0008/0/11
Germany	AD 2000- Merkblatt A2	S/G/L	TÜV SV 576	TÜV SV 576	TÜV SV 576	TÜV SV 576	TÜV SV 576	TÜV SV 576	TÜV SV 576	TÜV SV 934	TÜV SV 934
United States	ASME VIII	S/G	M37044	M37044	M37044	M37044	M37044	M37044	M37044	M37066 M37088	M37066 M37088
		L	M37055	M37055	M37055	M37055	M37055	M37055	M37055	M37077 M37099	M37077 M37099
Canada	CRN	S/G/L	OG1182.9C	OG1182.9C	OG1182.9C	OG1182.9C	OG1182.9C	OG1182.9C	OG1182.9C	-	-
China	CSBQTS	S/G/L	02301T	02301T	02301T	02301T	02301T	02301T	02301T	02301T	02301T
Russia	DIN GOST GOSGOTTECHNADZOR		✓	✓	✓	✓	✓	✓	-	-	✓

Classification societies

Bureau Veritas	BV	✓	✓	✓	-	-	-	-	-	-	-
Det Norske Veritas	DNV	✓	✓	-	-	-	-	-	-	-	-
Germanischer Lloyd	GL	✓	✓	✓	-	-	-	-	-	-	-
Lloyd's register EMEA	LREMEA	✓	✓	✓	-	-	-	-	-	-	-
Registro Italiano Navale	RINA	✓	✓	up to DN 250	-	-	-	-	-	-	-

General signs and symbols

*	This option is covered by standard design
✓	Available
-	Not possible

Signs and symbols for flange drillings and flange facings

*	Standard design, no option code required
(*)	Flange dimensions except flange thickness are in accordance with flange standard (e.g. ASME B16.5) Flange thickness is smaller (max. 2 mm), see "Multiple pressure rating"
-	Flange drilling/facing is not possible

Option code for flange drilling and dimension, e.g. H50

H50	Flange drilling as specified in flange standard Outer flange diameter, flange thickness and height of flange facing may be larger, see "Dimensions"
(H50)	Flange dimensions except flange thickness are in accordance with standard Flange thickness is smaller (max. 2 mm), see "Multiple pressure rating"
[H50]	Flange drilling as specified in standard/flange thickness may be smaller Outer flange diameter is smaller than required, but complete back side facing for nut is assured

Option code for flange facing, e.g. L36

L36	Flange facing as specified in flange standard
-----	-----------------------------------------------

General information concerning flange drillings and flange facings

Dimensions	<p>Flange dimensions of LESER Series 458 exceed flange dimension as mentioned in ASME / ANSI B16.5 and DIN EN 1092. This exceedance is in accordance with API Standard 526, Section 2.4.</p> <p>Dimensions: "For some valve designs, the inlet raised face height may substantially exceed the nominal dimension specified in ASME / ANSI B16.5 (and DIN EN 1092). Consult the manufacturer for exact dimension." The reason for this exceedance is:</p> <ul style="list-style-type: none"> - height of nozzle placed in the inlet of valve - due to the outer diameter of the nozzle thread flange thickness has to be thicker than normal ASME / ANSI B16.5 and DIN EN 1092 dimension to achieve the required pressure rating
Multiple pressure rating	The flange standard shows the same drilling, facing and outer diameter for several pressure ratings, e.g. PN 16 up to PN 40 Due to the pressure rating of the casting LESER fulfills the requirements for flange thickness e.g. of PN 16 but not PN 40
Smooth finish	The effective MSS SP-6 (Edition 2001) does not mention "smooth finish" anymore. In MSS SP-6 (Edition 1980) "smooth finish" is defined for finishes of contact flanges as "250 µinch (6,3 µm) AARH max.". LESER supplies flange facings according to ASME B16.5 – 1996, paragraph 6.4.4.3: "Either a serrated concentric or serrated spiral finish resulting in service finish from 125 µinch to 250 µinch average roughness shall be furnished." This finish meets the requirements of MSS SP-6 (Edition 1980), which is not valid anymore!
Stock finish	Stock finish is not defined in any technical standard. If purchase orders show "stock finish" LESER supplies standard facing according to DIN or ASME (marked with * in table "Flange facings" of each valve series).

Materials

Please find below a summary of material codes at LESER. Please note that

- for every body material an inspection certificate 3.1 according to EN 10204 is available
- many materials have a multiple inspection certificate 3.1.

Material code	Flanged safety valve body	Body material is certified with 3.1 (EN 10204) for the following materials	
		EN	ASME
1	Grey iron	0.6025	cast iron
2	Carbon steel	1.0619	WCB, WCC
4	Stainless steel	1.4408, 1.4581	CF8M (Charpy test at -196°C), CF10M
5	Nodular cast iron	0.7043	ductile Gr. 60-40-18
7	High temperature carbon steel	1.7357	WC6

Sample Determination of K_{dr}/α_w : Type 441, DIN, DN 25

Type 441, 442 DIN

Determination of coefficient of discharge in case of lift restriction or back pressure

h = Lift [mm]
 d_0 = Flow diameter [mm] of selected safety valve, refer to table article numbers
 h/d_0 = Ratio of lift / flow diameter
 p_{a0} = Back pressure [bar_a]
 p_0 = Set pressure [bar_a]
 p_{a0}/p_0 = Ratio of back pressure / set pressure
 K_{dr} = Coefficient of discharge acc. to DIN EN ISO 4126-1
 α_w = Coefficient of discharge acc. to AD 2000-Merkblatt A2
 K_b = Back pressure correction factor acc. to API 520 topic 3.3

Diagram for evaluation of ratio of lift / flow diameter (h/d_0) in reference to the coefficient of discharge (K_{dr}/α_w)

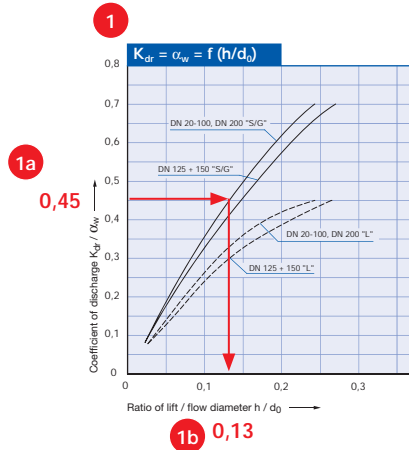
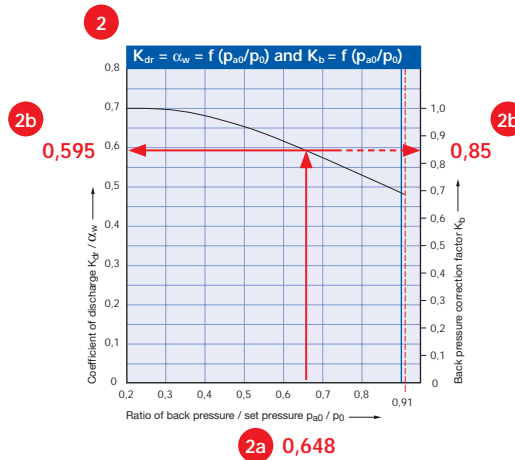

Diagram for evaluation of coefficient of discharge (K_{dr}/α_w) or K_b in reference to the ratio of back pressure / set pressure (p_{a0}/p_0)



Explanation

Sample – Type 441 DIN, DN 25, flow diameter $d_0 = 23$ mm, rated lift $h = 5,6$ mm, K_{dr}/α_w S/G = 0,7

1 Diagram 1 Determination of the restricted lift due to reduced K_{dr}/α_w			2 Diagram 2 Determination of reduced K_{dr}/α_w or K_b ¹⁾ due to back pressure		
Step	Description	Sample	Step	Description	Sample
1	Calculate the required coefficient of discharge of the selected safety valve. Applicable formulars are stated in codes and standards.	1a $K_{dr}/\alpha_w = 0,45$	1	Calculate the back pressure ratio p_{a0}/p_0 using the actual values for set pressure p_0 [bar _a] 0,45 and back pressure p_{a0} [bar _a] 0,292	2a $p_{a0}/p_0 = 0,648$
2	Select the starting point (0,45) at the Y-axis of the diagram.		2	Select the starting point (0,648) at the X-axis of the diagram.	
3	Lay a horizontal line onto the ratio graph to identify the intersection point.		3	Lay a vertical line onto the ratio graph to identify the intersection point.	
4	Lay a vertical line to the X-axis to identify the ratio of lift / flow diameter (h/d_0).	1b $h/d_0 = 0,13$	4	Lay a horizontal line to the Y-axis to identify the reduced K_{dr}/α_w or K_b .	2b $K_{dr}/\alpha_w = 0,595$ $K_b = 0,85$
5	Calculate the restricted lift using the formular $h = d_0 \times h/d_0$. (For ordering a lift restriction please use option code J51 refer to page 99/25)	$h = 23 \times 0,13$ $h = 3$ mm	5	Calculate the sizing with the established K_{dr}/α_w or K_b .	

Sample Capacity sheet –

How to select capacities for steam: Type 441 XXL DIN, DN 250

Capacities – Steam

Capacities for saturated steam according to AD 2000-Merkblatt A2, based on set pressure plus 10 % overpressure. ⁹

Capacities at 1 bar (14,5 psig) and below are based on 0,1 bar (1,45 psig) overpressure.

Capacities for saturated steam according to ASME Section VIII (UV), based on set pressure plus 10% overpressure.

Capacities at 2,07 bar (30 psig) and below are based on 0,207 bar (3 psig) overpressure.

Metric Units		AD 2000-Merkblatt A2 [kg/h]			
DN _{I+O}		200 x 300	250 x 350	300 x 400	400 x 500
Valve size		8" x 12"	10" x 14"	12" x 16"	16" x 20"
Act. Orifice dia. d ₀ [mm]		165	200	235	295
Act. Orifice area. d ₀ [mm]		21382	31416	43374	68349
LEO _{S/G} ^{*)} [inch ²]		23,761	34,910	48,198	75,952
Set pressure [bar]	Capacities [kg/h]				
0,1	0	0	0	0	0
0,2	7214	0	14633	0	0
0,5	11516	16920	23360	36811	0
1	16755	24617	33986	53556	0

US Units		ASME Section VIII [lb/h]			
DN _{I+O}		200 x 300	250 x 350	300 x 400	400 x 500
Valve size		8" x 12"	10" x 14"	12" x 16"	16" x 20"
Act. Orifice dia. d ₀ [inch]		6,5	7,87	9,25	11,61
Act. Orifice area. d ₀ [inch ²]		33,14	48,69	67,23	105,94
LEO _{S/G} ^{*)} [inch ²]		23,761	34,910	48,198	75,952
Set pressure [psig]	Capacities [lb/h]				
15	38962	57245	79034	124543	0
20	44928	66009	91134	143612	0
30	56859	83539	115336	181749	0
40	69983	102821	141958	223700	0

^{*)} LEO_{S/G} = LESER Effective Orifice steam/gas please refer to page 00/11

Explanation		Type 441 XXL			
No.	Description		Metric Units	US Units	Example
1	Code				AD 2000-Merkblatt A2
2	Nominal diameter inlet x outlet	DN _{I+O}			250 x 350
3	Valve size				10" x 14"
4	Actual orifice diameter	d ₀	[mm]	[inch]	200
5	Actual orifice area	A ₀	[mm ²]	[inch ²]	31416
6	LESER Effective Orifice	LEO _{S/G}	[inch ²]	[inch ²]	34,910
7	Set pressure		[bar _g]	[psig]	1
8	Capacity		[kg/h]	[lb/h]	24617
9	Base of calculation				see table page 00/10

9

Base of calculation

		Metric Units		US Units	
Code		Capacity calculation according to AD 2000-Merkblatt A2		Capacity calculation according to ASME Section VIII (UV)	
STEAM (saturated steam)	Standard conditions	Steam table IAPWS-IF97 IAPWS Industrial Formulation for the Thermodynamic Properties of Water and Steam		Steam table IAPWS-IF97 IAPWS Industrial Formulation for the Thermodynamic Properties of Water and Steam	
		[kg/h]		[lb/h]	
AIR	Standard conditions	0 °C and 1013 mbar		16 °C (60 °F)	
		[m _n ³ /h]		[S.C.F.M.]	
WATER	Standard conditions	20 °C (68 °F)		21 °C (70 °F)	
		[10 ³ kg/h]		[US-G.P.M.]	
	Calculation pressure	Set pressure plus 10 % overpressure		Set pressure plus 10 % overpressure	
	Calculation pressure for low set pressure	Capacities at 1 bar (14,5 psig) and below are based on 0,1 bar (1,45 psig) overpressure.		Capacities at 2,07 bar (30 psig) and below are based on 0,207 bar (3 psig) overpressure.	

Example

Capacity calculation pressure

Metric Units		US Units	
Set pressure	Capacity calculation pressure	Set pressure	Capacity calculation pressure
10 bar	10 bar + 10% overpressure = 11 bar	145 psig	145 psig + 10% overpressure = 159,5 psig
0,5 bar	0,5 bar + 0,1 bar overpressure = 0,6 bar	20 psig	20 psig + 3 psig overpressure = 23 psig

6

LESER Effective Orifice

Pressure relief devices may be initially sized using the equations shown in API RP 520, sections 3.6 through 3.10 as appropriate for vapors, gases, liquids, or two phase flow. These equations utilize effective coefficient of discharge (S/G 0,975, L 0,650) and effective areas (acc. to API Std. 526, Fifth Edition, June 2002, table 1) which are independent of any specific

valve design. In this way the designer can determine a preliminary pressure relief valve size. By using the LESER Effective Orifice the designer can directly select a LESER safety relief valve after calculating the orifice letter. In this case, a verification of the sizing with the selected actual orifice and the rated coefficient of discharge is not necessary.

LEO _{S/G}	LESER Effective Orifice (for steam, gas and vapor)	[inch ²]	refer to page 00/11
LEO _L	LESER Effective Orifice (for liquid)	[inch ²]	refer to page 00/12

For further information refer to LESER Engineering Handbook.

This table is based on the rated coefficient of discharge for steams and gases of LESER safety valves certified by ASME. The appropriated K-values are shown in the column "K-value" of the table.

LEO _{S/G}		LESER Effective Orifice (for steam, gas and vapor)							
Orifice acc. API 526	LESER-Series	DN	Inlet size	d ₀ [inch]	d ₀ [mm]	K-value	LEO _{S/G} [inch ²]	% of higher orifice	% of lower orifice
D							0,110	100,0%	100,0%
E							0,196	100,0%	100,0%
	458	25	1"	0,591	15,0	0,798	0,224	73,0%	114,4%
	441	20	3/4"	0,709	18,0	0,699	0,283	92,1%	114,3%
F							0,307	100,0%	100,0%
	458	25	1"	0,787	20,0	0,798	0,399	79,2%	129,8%
	441	25	1"	0,906	23,0	0,699	0,462	91,8%	150,4%
	441 Full nozzle	25	1"	0,906	23,0	0,699	0,462	91,8%	150,4%
	444	25	1"	0,906	23,0	0,699	0,462	91,8%	150,4%
G							0,503	100,0%	100,0%
	441	32	1 1/2"	1,142	29,0	0,699	0,734	93,5%	145,9%
	441 Full nozzle	32	1 1/2"	1,142	29,0	0,699	0,734	93,5%	145,9%
H							0,785	100,0%	100,0%
	458	50	2"	1,181	30,0	0,798	0,897	69,7%	114,2%
	441	40	1 1/2"	1,457	37,0	0,699	1,195	92,8%	152,2%
	441 Full nozzle	40	1 1/2"	1,457	37,0	0,699	1,195	92,8%	152,2%
	444	40	1 1/2"	1,457	37,0	0,699	1,195	92,8%	152,2%
J							1,287	100,0%	100,0%
	457, 458	50	2"	1,575	40,0	0,798	1,594	86,7%	123,9%
K							1,838	100,0%	100,0%
	441	50	2"	1,811	46,0	0,699	1,847	64,7%	100,5%
	441 Full nozzle	50	2"	1,811	46,0	0,699	1,847	64,7%	100,5%
	444	50	2"	1,811	46,0	0,699	1,847	64,7%	100,5%
	458	80	3"	1,969	50,0	0,798	2,491	87,3%	135,5%
	458	100	4"	1,969	50,0	0,798	2,491	87,3%	135,5%
L							2,853	100,0%	100,0%
	441	65	3"	2,362	60,0	0,699	3,142	87,3%	110,1%
	441 Full nozzle	65	3"	2,362	60,0	0,699	3,142	87,3%	110,1%
	444	65	2 1/2"	2,362	60,0	0,699	3,142	87,3%	110,1%
	458	80	3"	2,362	60,0	0,754	3,389	94,1%	118,1%
	458	100	4"	2,362	60,0	0,798	3,587	99,6%	125,7%
M							3,600	100,0%	100,0%
N							4,340	100,0%	100,0%
	441	80	-	2,913	74,0	0,699	4,779	74,9%	110,1%
	444	80	3"	2,913	74,0	0,699	4,779	74,9%	110,1%
	458	100	4"	2,913	74,0	0,798	5,456	85,5%	125,7%
P							6,380	100,0%	100,0%
	458	100	4"	3,465	88,0	0,754	7,290	66,0%	114,3%
	441	100	4"	3,622	92,0	0,699	7,387	66,9%	115,8%
	441 Full nozzle	100	4"	3,622	92,0	0,699	7,387	66,9%	115,8%
	441	125	5"	3,858	98,0	0,699	8,382	75,9%	131,4%
Q							11,050	100,0%	100,0%
	458	150	6"	4,331	110,0	0,754	11,391	71,2%	103,1%
	441	150	6"	4,921	125,0	0,699	13,637	85,2%	123,4%
R							16,000	100,0%	100,0%
	441	200	8"	6,496	165,0	0,699	23,761	91,4%	148,5%
	XXL	200	8"	6,496	165,0	0,699	23,761	91,4%	148,5%
T							26,000	100,0%	100,0%
	XXL	250	10"	7,874	200,0	0,699	34,910		134,3%
	XXL	300	12"	9,252	235,0	0,699	48,198		185,4%
	XXL	400	16"	11,614	295,0	0,699	75,952		292,1%

This table is based on the rated coefficient of discharge for liquids of LESER safety valves certified by ASME.
The appropriated K-values are shown in the column "K-value" of the table.

LEOL		LESER Effective Orifice (for liquid)							
Orifice acc. API 526	LESER-Series	DN	Inlet size	d ₀ [inch]	d ₀ [mm]	K-value	LEOL [inch ²]	% of higher orifice	% of lower orifice
D							0,110	100,0%	100,0%
E							0,196	100,0%	100,0%
	458	25	1"	0,591	15	0,572	0,241	78,5%	123,0%
F							0,307	100,0%	100,0%
	441	20	3/4"	0,709	18	0,521	0,316	62,9%	103,0%
	458	25	1"	0,787	20	0,572	0,429	85,2%	139,6%
G							0,503	100,0%	100,0%
	441	25	1"	0,906	23	0,521	0,516	65,8%	102,6%
	441 Full nozzle	25	1"	0,906	23	0,521	0,516	65,8%	102,6%
	444	25	1"	0,906	23	0,521	0,516	65,8%	102,6%
H							0,785	100,0%	100,0%
	441	32	1 1/2"	1,142	29	0,521	0,821	6,38%	104,5%
	441 Full nozzle	32	1 1/2"	1,142	29	0,521	0,821	6,38%	104,5%
	458	50	1"	1,181	30	0,572	0,964	74,9%	122,8%
J							1,287	100,0%	100,0%
	441	40	1 1/2"	1,457	37	0,521	1,336	72,7%	103,8%
	441 Full nozzle	40	1 1/2"	1,457	37	0,521	1,336	72,7%	103,8%
	444	40	1 1/2"	1,457	37	0,521	1,336	72,7%	103,8%
	458	50	2"	1,575	40	0,572	1,714	93,3%	133,2%
K							1,838	100,0%	100,0%
	441	50	2"	1,811	46	0,521	2,065	72,4%	112,3%
	441 Full nozzle	50	2"	1,811	46	0,521	2,065	72,4%	112,3%
	444	50	2"	1,811	46	0,521	2,065	72,4%	112,3%
	458	80	3"	1,969	50	0,527	2,678	93,9%	145,7%
	458	100	4"	1,969	50	0,527	2,678	93,9%	145,7%
L							2,853	100,0%	100,0%
	458	80	3"	2,362	60	0,479	3,230	89,7%	113,2%
	441	65	3"	2,362	60	0,521	3,513	97,6%	123,1%
	441 Full nozzle	65	3"	2,362	60	0,521	3,513	97,6%	123,1%
	444	65	2 1/2"	2,362	60	0,521	3,513	97,6%	123,1%
M							3,600	100,0%	100,0%
	458	100	4"	2,362	60	0,572	3,857	88,9%	107,1%
N							4,340	100,0%	100,0%
	441	80	-	2,913	74	0,521	5,343	83,3%	123,1%
	444	80	3"	2,913	74	0,521	5,343	83,3%	123,1%
	458	100	4"	2,913	74	0,572	5,866	91,9%	135,2%
P							6,380	100,0%	100,0%
	458	100	4"	3,465	88	0,479	6,947	62,9%	108,9%
	441	100	4"	3,622	92	0,521	8,259	74,7%	129,4%
	441 Full nozzle	100	4"	3,622	92	0,521	8,259	74,7%	129,4%
	441	125	5"	3,858	98	0,521	9,371	84,8%	146,9%
	458	150	6"	4,331	110	0,479	10,855	98,2%	170,1%
Q							11,050	100,0%	100,0%
	441	150	6"	4,921	125	0,521	15,246	95,3%	138,0%
R							16,000	100,0%	100,0%
T							26,000	100,0%	100,0%
	441	200	8"	6,496	165	0,521	26,565		102,0%
	XXL	200	8"	6,496	165	0,521	39,031		102,0%
	XXL	250	10"	7,874	200	0,521	39,031		150,1%
	XXL	300	12"	9,252	235	0,521	53,887		207,3%
	XXL	400	16"	11,614	295	0,521	84,916		326,6%

Sour gas service (H₂S)

Normative basis

In accordance with NACE standard MR 0175-2003 sour gas service means the presence of H₂S in the following conditions:

Part 1.4.1.1.: All gas, gas condensate, and sour crude oil – When the partial pressure of H₂S in a wet (water as a liquid) gas phase of a gas, gas condensate, or crude oil system is equal to or exceeds 0,003 bar_a (0,05 psia)

Exceptions are:

Part 1.4.2.1.: **Low-pressure gas:** When the total pressure is lower than 4,5 bar_a (65 psia)

Part 1.4.2.2.: **Low-pressure oil and gas multiphase systems:** ...

Other Sour gas standards:

NACE MR 0103-2003: Materials resistance to sulfide stress cracking in corrosive petroleum refining environments.

DIN EN ISO 15156-1: Petroleum and natural gas industries – Materials for use in H₂S-containing environments in oil and gas production – Part 1: General principles for selection of cracking-resistant materials (ISO 15156-1:2001)

Miscellaneous

Workstandards: Please refer to LWN 001.91

General requirements for sour gas service

The above mentioned standards require a maximum hardness of 22 HRC for the most steels.

For the actual requirements of a specific material please refer to the applied standard.

LESER sour gas level

General: Sour gas material requirements must be fulfilled if pressure and partial pressure conditions according to the applied standard exist.

Based on these general statement LESER defines two sour gas level for safety valves:

Part definition	Level 1		Level 2	
	Contact with the medium in closed position		Contact with the medium in opened position	
	Conventional	Balanced bellows	Conventional	Balanced bellows
Contact area				
Pressure requirements	Set pressure ≥ 4,5 bar _a (65 psia)		Back pressure ≥ 4,5 bar _a (65 psia)	
Safety valve operation	closed		closed / opened	
Parts concerned	Conventional design	Body / Nozzle Disc	All	
	Balanced bellows design	Body / Nozzle Disc	Body / Nozzle Disc Bonnet spacer Bellows	

Necessary material modification

Type	Body material	Design	Part	Material	Option code	Material	Option code
4412 DIN 4412 ANSI 4412 Full nozzle DIN 4412 Full nozzle ANSI	1.0619 (WCB)	Conventional	Disc	1.4404 / 316L	L44	Please choose balanced bellows design	
Balanced bellows		Disc	1.4404 / 316L	L44	1.4404 / 316L	L44	
		Bellows	1.4571 / 316Ti	J78	1.4571 / 316Ti	J78	
4414 DIN 4414 ANSI 4414 Full nozzle DIN 4414 Full nozzle ANSI	1.4408 (CF8M)	Conventional		No modification required		No modification required	
Balanced bellows		Bellows	1.4571 / 316Ti	J78	1.4571 / 316Ti	J78	
4412 XXL	1.0460 / 1.0425 (Carbon steel)	Conventional	Disc	No modification required		Please choose balanced bellows design	
		Balanced bellows	Disc	No modification required		No modification required	
			Bellows	1.4571 / 316Ti	J78	1.4571 / 316Ti	J78
4414 XXL	1.4571 (316Ti)	Conventional		No modification required		No modification required	
		Balanced bellows	Bellows	1.4571 / 316Ti	J78	1.4571 / 316Ti	J78
4444 DIN 4444 ANSI	1.4404 (316L)	Conventional		No modification required		No modification required	
4562, 4582 4587	1.0619 (WCB) 1.7357 (WC6)	Conventional	Disc	1.4404 / 316L	L44	Please choose balanced bellows design	
		Balanced bellows	Disc	1.4404 / 316L	L44	1.4404 / 316L	L44
			Bellows	1.4571 / 316Ti	J78	1.4571 / 316Ti	J78
4584	1.4581 (CF10M)	Conventional		No listed in NACE		No listed in NACE	
		Balanced bellows		No listed in NACE		No listed in NACE	

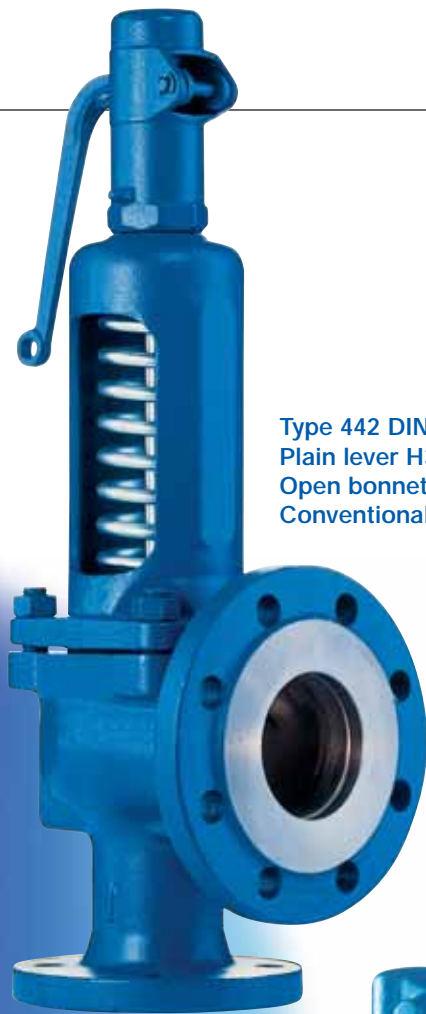

Type 442 DIN
Plain lever H3
Open bonnet
Conventional design



Type 441 DIN
Packed lever H4
Closed bonnet
Conventional design

Type 441 DIN 442 DIN

Type 441, 442 DIN

Flanged Safety Relief Valves – spring loaded

Contents

Chapter/Page

Materials

- Conventional design 01/02
- Balanced bellows design 01/04

How to order

- Numbering system 01/06
- Article numbers 01/08

Dimensions and weights

- Metric Units 01/10
- US Units 01/11

Pressure temperature ratings

- Metric Units 01/12
- US Units 01/14

Flange drillings and facings 01/16

Order information – Spare parts 01/18

Available options 01/20

Approvals 01/21

Capacities

- Steam [Metric Units + US Units] 01/22
- Air [Metric Units + US Units] 01/24
- Water [Metric Units + US Units] 01/26

Determination of coefficient
of discharge K_{dr}/α_w 01/28

Type 441, 442 DIN

Conventional design

Type 441, 442 DIN

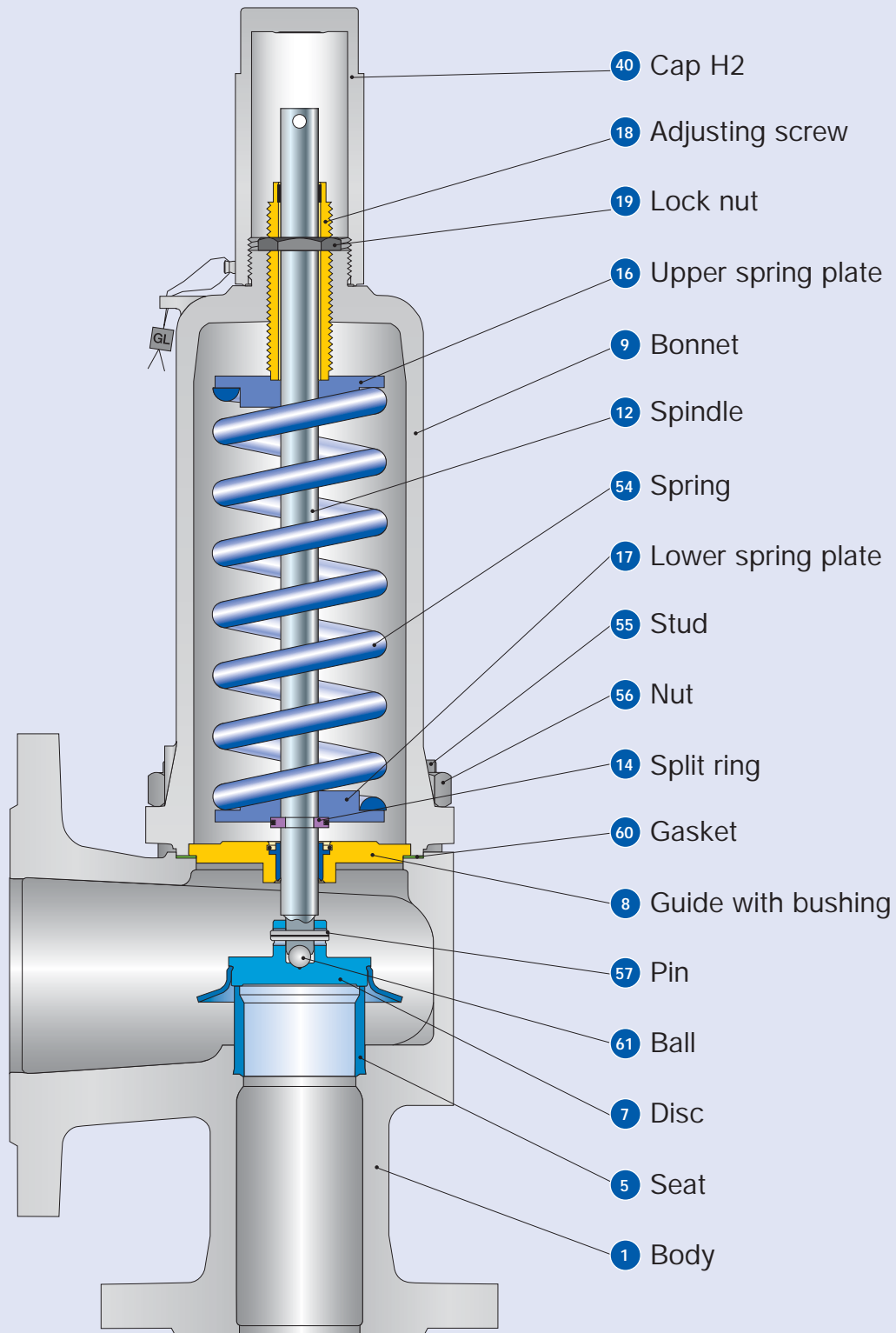

Conventional design

Materials		Type 4411 / 4421 DIN	Type 4415 / 4425 DIN	Type 4412 / 4422 DIN	Type 4414 DIN
1	Body	0.6025	0.7043	1.0619	1.4408
		Cast iron	Ductile Gr. 60-40-18	SA 216 WCB	SA 351 CF8M
5	Seat	1.4404	1.4404	1.4404	1.4404
		316L	316L	316L	316L
7	Disc	1.4122	1.4122	1.4122	1.4404
		Hardened stainless steel	Hardened stainless steel	Hardened stainless steel	316L
8	Guide with bushing	1.4104, 1.0501, 0.7040	1.4104, 1.0501, 0.7040	1.4104, 1.0501, 0.7040	1.4404
		Chrome or carbon steel	Chrome or carbon steel	Chrome or carbon steel	316L
		1.4104 tenifer	1.4104 tenifer	1.4104 tenifer	-
		Chrome steel tenifer	Chrome steel tenifer	Chrome steel tenifer	-
9	Bonnet	0.7040, 0.7043, 1.0619	0.7040, 0.7043, 1.0619	0.7040, 0.7043, 1.0619	1.4408, 1.4404, 1.4571
		Ductile Gr. 60-40-18, SA 216 WCB	Ductile Gr. 60-40-18, SA 216 WCB	Ductile Gr. 60-40-18, SA 216 WCB	SA 351 CF8M, SA 479 316L, SA 479 316Ti
12	Spindle	1.4021	1.4021	1.4021	1.4404
		420	420	420	316L
14	Split ring	1.4104	1.4104	1.4104	1.4404
		Chrome steel	Chrome steel	Chrome steel	316L
16/17	Spring plate	1.0718	1.0718	1.0718	1.4404
		Steel	Steel	Steel	316L
18	Adjusting screw with bushing	1.4104 PTFE	1.4104 PTFE	1.4104 PTFE	1.4404 PTFE
		Chrome steel PTFE	Chrome steel PTFE	Chrome steel PTFE	316L PTFE
19	Lock nut	1.0718	1.0718	1.0718	1.4404
		Steel	Steel	Steel	316L
40	Cap H2	1.0718 or 0.7043	1.0718 or 0.7043	1.0718 or 0.7043	1.4404
		12L13 or Gr. 60-40-18	12L13 or Gr. 60-40-18	12L13 or Gr. 60-40-18	316L
54	Spring standard	1.1200, 1.8159, 1.7102	1.1200, 1.8159, 1.7102	1.1200, 1.8159, 1.7102	1.4310
		Carbon steel	Carbon steel	Carbon steel	Stainless steel
54	Spring optional	1.4310	1.4310	1.4310	-
		Stainless steel	Stainless steel	Stainless steel	-
55	Stud	1.1181	1.1181	1.1181	1.4401
		Steel	Steel	Steel	B8M
56	Nut	1.0501	1.0501	1.0501	1.4401
		2H	2H	2H	8M
57	Pin	1.4310	1.4310	1.4310	1.4310
		Stainless steel	Stainless steel	Stainless steel	Stainless steel
60	Gasket	Graphite / 1.4401	Graphite / 1.4401	Graphite / 1.4401	Graphite / 1.4401
		Graphite / 316	Graphite / 316	Graphite / 316	Graphite / 316
61	Ball	1.3541	1.3541	1.3541	1.4401
		Hardened stainless steel	Hardened stainless steel	Hardened stainless steel	316

Please notice:

- Modifications reserved by LESER.
- LESER can upgrade materials without notice.
- Every part can be replaced by other material acc. to customer specification.

Type 441, 442 DIN

Balanced bellows design

Type 441, 442 DIN

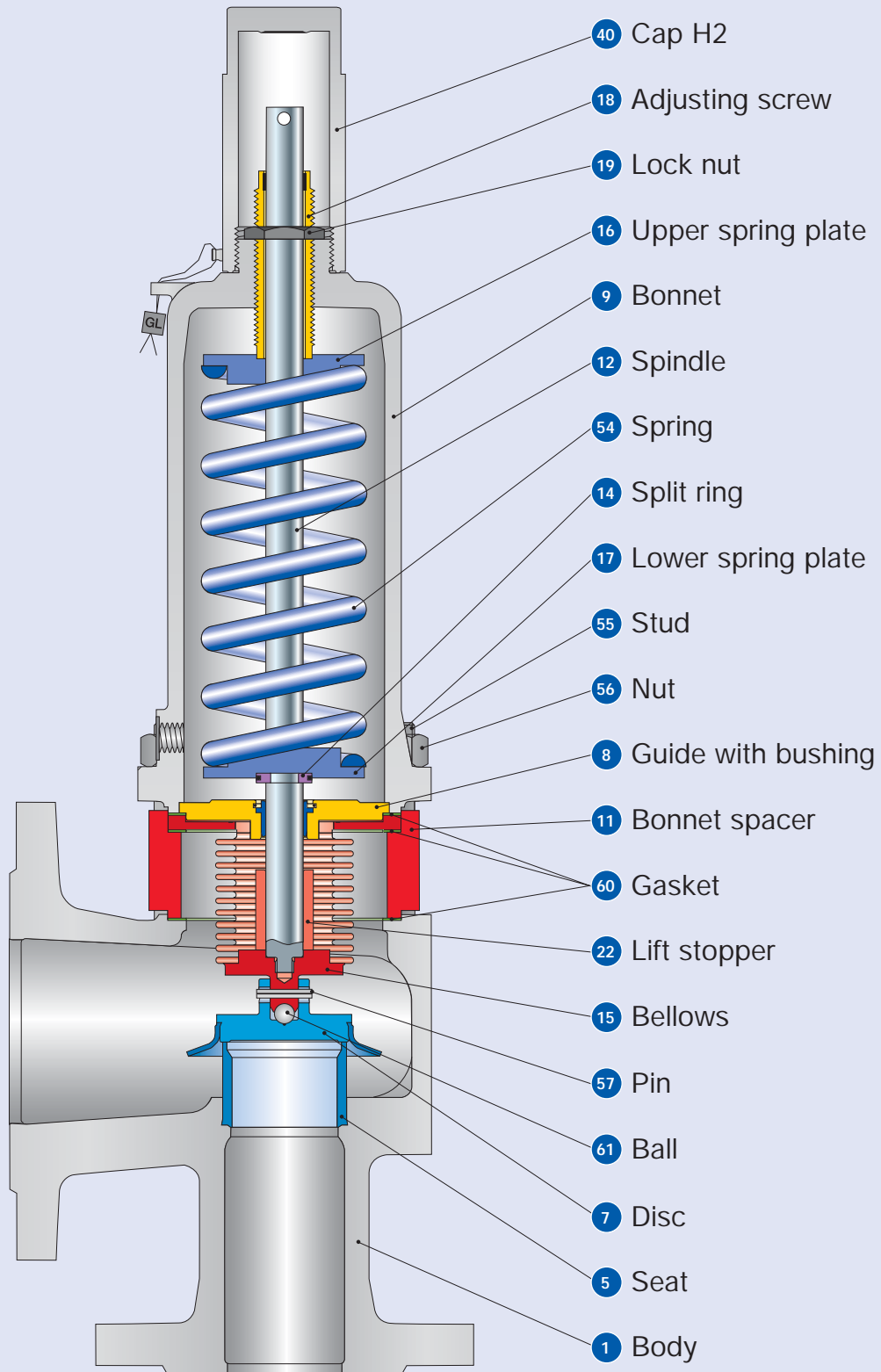

Balanced bellows design

Materials					
Item	Component	Type 4411 / 4421 DIN	Type 4415 / 4425 DIN	Type 4412 / 4422 DIN	Type 4414 DIN
1	Body	0.6025	0.7043	1.0619	1.4408
		Cast iron	Ductile Gr. 60-40-18	SA 216 WCB	SA 351 CF8M
5	Seat	1.4404	1.4404	1.4404	1.4404
		316L	316L	316L	316L
7	Disc	1.4122	1.4122	1.4122	1.4404
		Hardened stainless steel	Hardened stainless steel	Hardened stainless steel	316L
8	Guide with bushing	1.4104, 1.0501, 0.7040	1.4104, 1.0501, 0.7040	1.4104, 1.0501, 0.7040	1.4404
		Chrome or carbon steel	Chrome or carbon steel	Chrome or carbon steel	316L
		1.4104 tenifer	1.4104 tenifer	1.4104 tenifer	-
		Chrome steel tenifer	Chrome steel tenifer	Chrome steel tenifer	-
9	Bonnet	0.7040, 0.7043, 1.0619	0.7040, 0.7043, 1.0619	0.7040, 0.7043, 1.0619	1.4408, 1.4404, 1.4571
		Ductile Gr. 60-40-18, SA 216 WCB	Ductile Gr. 60-40-18, SA 216 WCB	Ductile Gr. 60-40-18, SA 216 WCB	SA 351 CF8M, SA 479 316L, SA 479 316Ti
11	Bonnet spacer	1.0460	1.0460	1.0460	1.4404
		Carbon steel	Carbon steel	Carbon steel	316L
12	Spindle	1.4404	1.4404	1.4404	1.4404
		316L	316L	316L	316L
14	Split ring	1.4104	1.4104	1.4104	1.4404
		Chrome steel	Chrome steel	Chrome steel	316L
15	Bellows	1.4571	1.4571	1.4571	1.4571
		316Ti	316Ti	316Ti	316Ti
16/17	Spring plate	1.0718	1.0718	1.0718	1.4404
		Steel	Steel	Steel	316L
18	Adjusting screw with bushing	1.4104 PTFE	1.4104 PTFE	1.4104 PTFE	1.4404 PTFE
		Chrome steel PTFE	Chrome steel PTFE	Chrome steel PTFE	316L PTFE
19	Lock nut	1.0718	1.0718	1.0718	1.4404
		Steel	Steel	Steel	316L
22	Lift stopper	1.4404	1.4404	1.4104	1.4404
		316L	316L	Chrome steel	316L
40	Cap H2	1.0718 or 0.7043	1.0718 or 0.7043	1.0718 or 0.7043	1.4404
		12L13 or Gr. 60-40-18	12L13 or Gr. 60-40-18	12L13 or Gr. 60-40-18	316L
54	Spring standard	1.1200, 1.8159, 1.7102	1.1200, 1.8159, 1.7102	1.1200, 1.8159, 1.7102	1.4310
		Carbon steel	Carbon steel	Carbon steel	Stainless steel
54	Spring optional	1.4310	1.4310	1.4310	-
		Stainless steel	Stainless steel	Stainless steel	-
55	Stud	1.4401	1.4401	1.4401	1.4401
		B8M	B8M	B8M	B8M
56	Nut	1.4401	1.4401	1.4401	1.4401
		8M	8M	8M	8M
57	Pin	1.4310	1.4310	1.4310	1.4310
		Stainless steel	Stainless steel	Stainless steel	Stainless steel
60	Gasket	Graphite / 1.4401	Graphite / 1.4401	Graphite / 1.4401	Graphite / 1.4401
		Graphite / 316	Graphite / 316	Graphite / 316	Graphite / 316
61	Ball	1.3541	1.3541	1.3541	1.4401
		Hardened stainless steel	Hardened stainless steel	Hardened stainless steel	316

Please notice:

- Modifications reserved by LESER.
- LESER can upgrade materials without notice.
- Every part can be replaced by other material acc. to customer specification.

How to order – Numbering system

1

Article Number

1	2	3	4
441	2	451	2

1 Valve Type 441, 442 DIN
 Type 441 – with closed bonnet
 Type 442 – with open bonnet

2 Material code

Code	Lifting lever
1	0.6025 (cast iron)
2	1.0619 (WCB)
4	1.4408 (CF8M)
5	0.7043 (ductile Gr. 60-40-18)

3 Valve code
 Identifies valve size and body material, refer to page 01/09.

4

Code	Lifting lever	
2	screwed cap	H2
3	plain lever	H3
4	packed lever	H4
5	plain lever with open bonnet	H3

4412.4512

Article No.

2

Set Pressure

Please state unit (in gauge)!

Please do not exceed the pressure range defined in the spring charts.

5 barg

Set Pressure

3

Connections

Please refer to pages 01/16 and 01/17

H45

Connections

4 Options

Type 441, 442 DIN	Option code
• O-ring-disc	
CR "K"	J21
EPDM "D"	J22
FKM "L"	J23
FFKM "C"	J20
• Disc 1.4404 / 316L	L44
• Disc 1.4404 / 316L stellited	J25
• Detachable lifting aid	J26
• Stainless steel bellows	
- open bonnet (Type 442)	J68
- closed bonnet (Type 441)	J78
• Elastomer bellows	J79
• High temperature alloy spring	X01
• Stainless steel spring	X04
• Adaptor for lift indicator H4	J39
• Lift indicator	J93
• Test gag	
- cap H2	J70
- packed lever H4	J69
• Heating jacket	
- Couplings G 3/8	H29
G 3/4	H30
- Flanges DN 15	H31
DN 25	H32
• Drain hole G 1/4	J18
G 1/2	J19
• Free of oil and grease	J85
• Materials	
- NACE	H01

Option code applies only if not standard

J22

Options

5 Documentation

Please select requested documentation:

Inspections, tests:	Option code
DIN EN 10204-3.2: TÜV-Nord Certificate for test pressure	M33
LESER Certificate for Global Application	H03
- Inspection certificate 3.1 acc. to DIN EN 10204	
- Declaration of conformity acc. to PED 97/23/EC	
Material test certificate:	
DIN EN 10204-3.1	
Part	Option code
Body	H01
Bonnet	L30
Cap / lever cover	L31
Disc	L23
Studs	N07
Nuts	N08

H01 L30

Documentation

6 Code and Medium

1	2
2	0
1 Code	
1. ASME Section VIII	
2. CE / VdTUEV	
3. ASME Section VIII + CE / VdTUEV	
2 Medium	
.1 Gases	
.2 Liquids	
.3 Steam	
.0 Steam / Gases / Liquids (valid only for CE / VdTUEV)	

2.0

Code and Medium

Type 441, 442 DIN

How to order – Article numbers

Type 441, 442 DIN

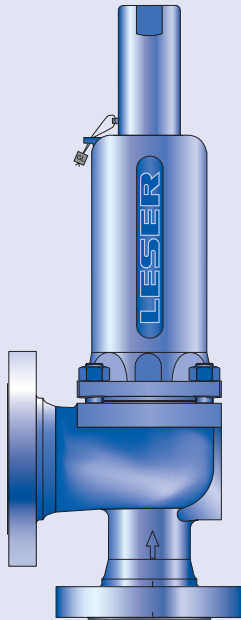

Type 441
Cap H2
Closed bonnet
Conventional design

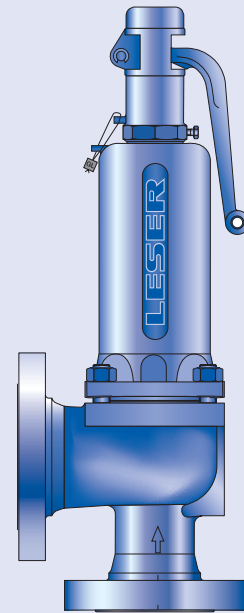

Type 441
Plain lever H3
Closed bonnet
Conventional design

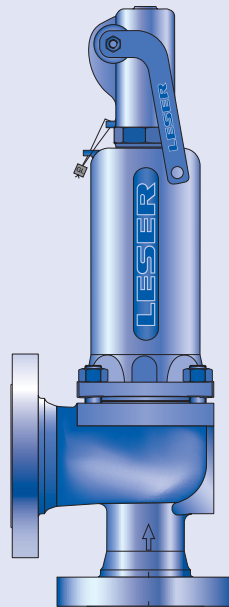

Type 441
Packed lever H4
Closed bonnet
Conventional design

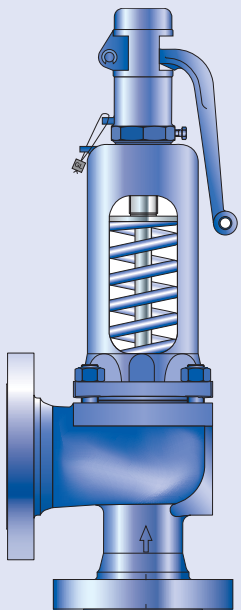

Type 442
Plain lever H3
Open bonnet
Conventional design

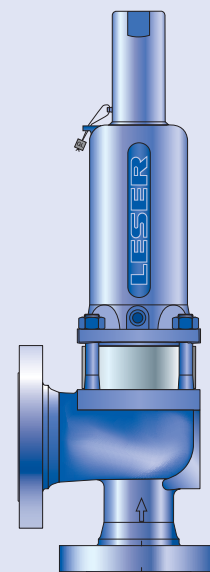

Type 441
Cap H2
Closed bonnet
Balanced bellows design

How to order – Article numbers

Article numbers			DN _i	20	20	25	32	40	50	65	80	100	125	150	200
			DN _o	32	40	40	50	65	80	100	125	150	200	250	300
			Actual Orifice diameter d ₀ [mm]	18	18	23	29	37	46	60	74	92	98	125	165
			Actual Orifice area A ₀ [mm ²]	254	254	416	661	1075	1662	2827	4301	6648	7543	12272	21382
Body material: 0.6025 (cast iron)															
Bonnet closed	H2	Art.-No. 4411.	4372	–	4382	4392	4402	4412	4422	4432	4442	4452	4462	–	–
	H3	Art.-No. 4411.	4373	–	4383	4393	4403	4413	4423	4433	4443	4453	–	–	–
	H4	Art.-No. 4411.	4374	–	4384	4394	4404	4414	4424	4434	4444	4454	4464	–	–
open	H3	Art.-No. 4421.	4375	–	4385	4395	4405	4415	4425	4435	4445	4455	4465	–	–
Body material: 0.7043 (ductile Gr. 60-40-18)															
Bonnet closed	H2	Art.-No. 4415.	–	–	7382	7392	7402	7412	7422	7432	7442	7452	7462	7472	–
	H3	Art.-No. 4415.	–	–	7383	7393	7403	7413	7423	7433	7443	7453	–	–	–
	H4	Art.-No. 4415.	–	–	7384	7394	7404	7414	7424	7434	7444	7454	7464	7474	–
open	H3	Art.-No. 4425.	–	–	7385	7395	7405	7415	7425	7435	7445	7455	7465	7475	–
Body material: 1.0619 (WCB)															
Bonnet closed	H2	Art.-No. 4412.	–	4502	4512	4522	4532	4542	4552	4562	4572	4582	4592	4612	–
	H3	Art.-No. 4412.	–	4503	4513	4523	4533	4543	4553	4563	4573	4583	–	–	–
	H4	Art.-No. 4412.	–	4504	4514	4524	4534	4544	4554	4564	4574	4584	4594	4614	–
open	H3	Art.-No. 4422.	–	4505	4515	4525	4535	4545	4555	4565	4575	4585	4595	4615	–
Body material: 1.4408 (CF8M)															
Bonnet closed	H2	Art.-No. 4414.	–	–	4642	4652	4662	4672	4682	4692	4702	4712	4722	–	–
	H4	Art.-No. 4414.	–	–	4644	4654	4664	4674	4684	4694	4704	4714	4724	–	–

Type 441, 442 DIN

Dimensions and weights

Metric Units

	DN _i	20	20	25	32	40	50	65	80	100	125	150	200
	DN _o	32	40	40	50	65	80	100	125	150	200	250	300
	Actual Orifice diameter d ₀ [mm]	18	18	23	29	37	46	60	74	92	98	125	165
	Actual Orifice area A ₀ [mm ²]	254	254	416	661	1075	1662	2827	4301	6648	7543	12272	21382
Weight [kg]		9	9	9	12	16	22	32	56	75	85	131	285
	with bellows	9,4	9,4	10	13	17	24	36	60	83	93	142	289
Center to face [mm]	Inlet a	85	85	105	115	140	150	170	195	220	250	285	400
	Outlet b	95	95	100	110	115	120	140	160	180	200	225	477
Height (H4) [mm]	Standard H max.	304	304	339	446	512	569	699	801	883	913	1083	1380
	Bellows H max.	337	337	378	488	550	615	769	860	939	969	1141	1380
Support brackets [mm] (drilled only on request)	A									277	277	320	490
	B									160	160	185	1)
	C									Ø 18	Ø 18	Ø 18	Ø 18
	D									293	318	392	1)
	E									21	21	28	1)

Body material: 0.6025 (cast iron)

DIN Flange²⁾	Inlet	PN 16	-										PN 16
	Outlet	PN 16	-										PN 16

Body material: 0.7043 (ductile Gr. 60-40-18)

DIN Flange²⁾	Inlet	-	-										PN 25
	Outlet	-	-										PN 10

Body material: 1.0619 (WCB)

DIN Flange²⁾	Inlet	-	-										PN 25
	Outlet	-	-										PN 16

Body material: 1.4408 (CF8M)

DIN Flange²⁾	Inlet	-	-										PN 40
	Outlet	-	-										PN 16

1)

Body material	B [mm]	D [mm]	E [mm]
0.6025	150	290	16
0.7043	150	489	25
1.0619	160	489	25
1.4408	150	489	25

²⁾ Standard flange rating. For other flange drillings and facings please refer to page 01/16 and 01/17.

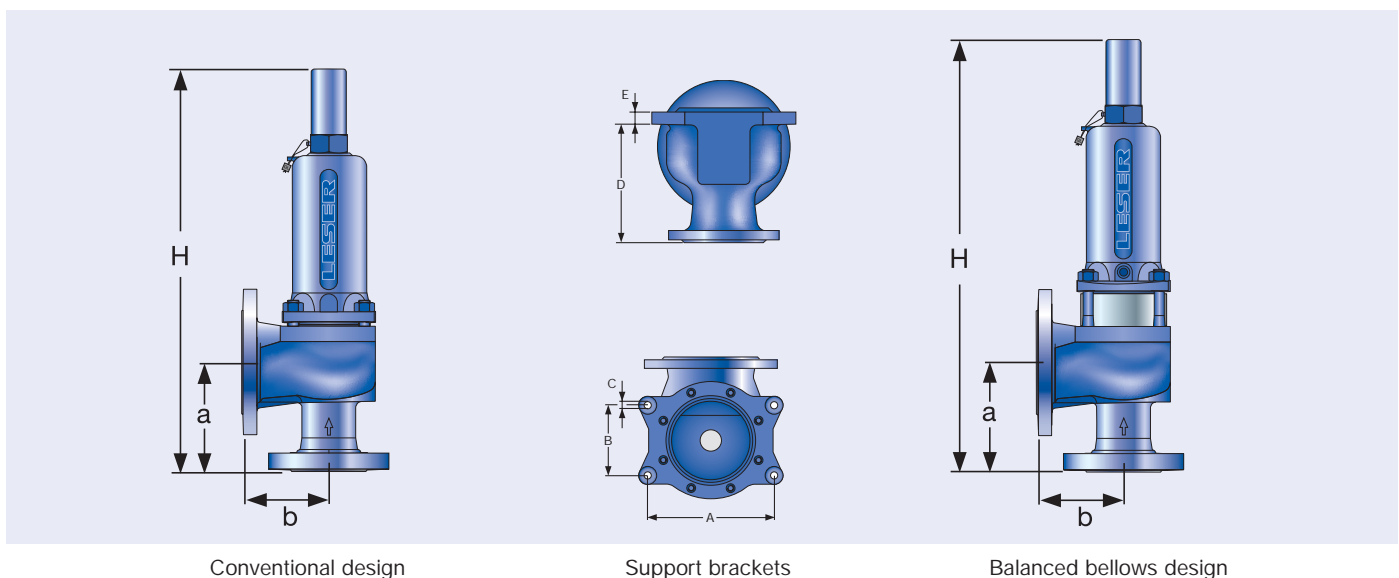

Dimensions and weights

US Units													
	DN _I	20	20	25	32	40	50	65	80	100	125	150	200
	DN _O	32	40	40	50	65	80	100	125	150	200	250	300
	Actual Orifice diameter d ₀ [inch]	0,71	0,71	0,91	1,14	1,46	1,81	2,36	2,91	3,62	3,86	4,92	6,5
	Actual Orifice area A ₀ [inch ²]	0,394	0,394	0,644	1,024	1,667	2,576	4,383	6,666	10,304	11,691	19,021	33,142
Weight [lbs]		20	20	20	26	35	49	71	123	165	187	289	628
	with bellows	21	21	21	28	38	52	79	132	183	205	313	637
Center to face [inch]	Inlet a	3 11/32	3 11/32	4 1/8	4 17/32	5 16/32	5 29/32	6 11/16	7 11/16	8 21/32	9 27/32	11 7/32	15 3/4
	Outlet b	3 3/4	3 3/4	3 15/16	4 11/32	4 17/32	4 23/32	5 16/32	6 5/16	7 3/32	7 7/8	8 27/32	8 25/32
Height (H4) [inch]	Standard H max.	11 13/16	11 13/16	13 11/32	17 9/16	20 5/32	22 13/32	27 17/32	31 17/32	34 3/4	35 15/16	42 5/8	54 11/32
	Bellows H max.	13 9/32	13 9/32	14 7/8	19 7/32	21 21/32	24 7/32	30 9/32	33 27/32	36 31/32	38 5/32	45	54 11/32
Support brackets [inch] (drilled only on request)	A									10 29/32	10 29/32	12 19/32	19 19/32
	B									6 1/4	6 1/4	7 9/32	1)
	C									Ø 3/4	Ø 3/4	Ø 3/4	Ø 3/4
	D									11 17/32	12 17/32	15 7/16	1)
	E									26/32	26/32	1 3/32	1)

Body material: 0.6025 (cast iron)

DIN Flange ²⁾	Inlet	PN 16	-										PN 16
	Outlet	PN 16	-										PN 16

Body material: 0.7043 (ductile Gr. 60-40-18)

DIN Flange ²⁾	Inlet	-	-										PN 40	PN 16	PN 25
	Outlet	-	-										PN 16		PN 10

Body material: 1.0619 (WCB)

DIN Flange ²⁾	Inlet	-	-										PN 40		PN 25
	Outlet	-	-										PN 16		

Body material: 1.4408 (CF8M)

DIN Flange ²⁾	Inlet	-	-										PN 40		
	Outlet	-	-										PN 16		

1)

Body material	B	D	E
	[inch]	[inch]	[inch]
0.6025	5 29/32	11 13/32	5/8
0.7043	5 29/32	11 17/32	13/16
1.0619	6 1/4	11 17/32	13/16
1.4408	5 29/32	11 17/32	13/16

2) Standard flange rating. For other flange drillings and facings please refer to page 01/16 and 01/17.

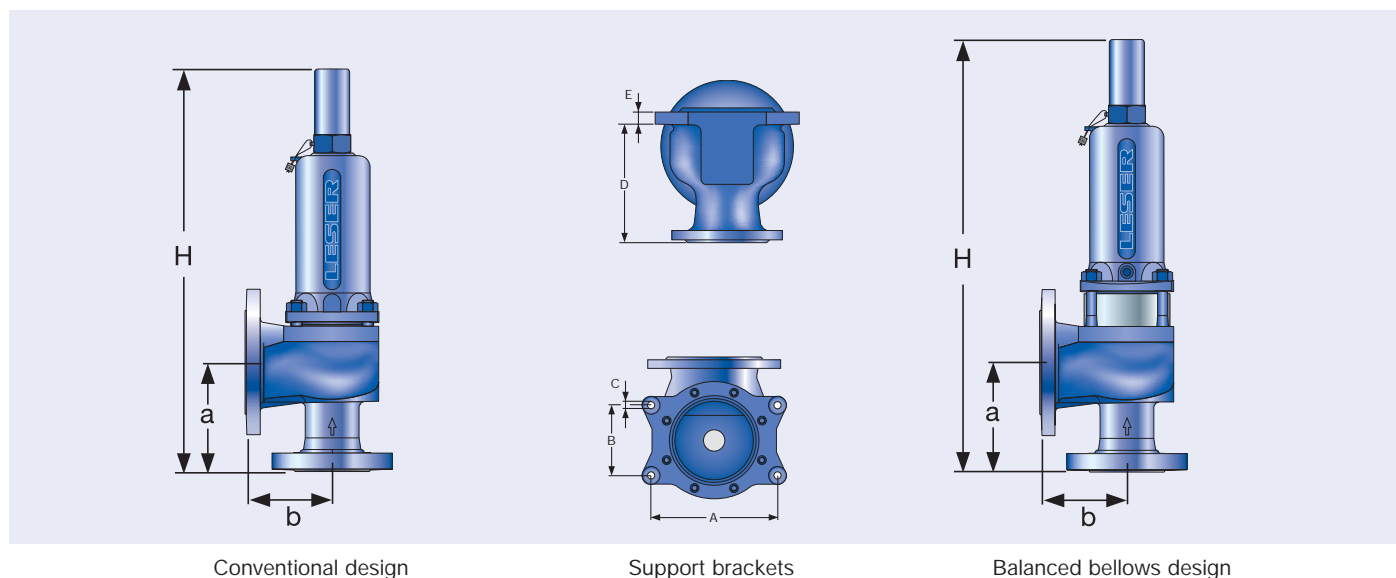

Pressure temperature ratings

Metric Units

	DN _I	20	20	25	32	40	50	65	80	100	125	150	200
	DN _O	32	40	40	50	65	80	100	125	150	200	250	300
	Actual Orifice diameter d ₀ [mm]	18	18	23	29	37	46	60	74	92	98	125	165
	Actual Orifice area A ₀ [mm ²]	254	254	416	661	1075	1662	2827	4301	6648	7543	12272	21382
Body material: 0.6025 (cast iron)													
DIN Flange	Inlet	PN 16	-	PN 16									-
	Outlet	PN 16	-	PN 16									-
Minimum set pressure	p [bar _g] S/G/L	0,1	-	0,1	0,1	0,1	0,1	0,1	0,1	0,1	0,1	0,1	-
Min. set pressure¹⁾ standard bellows	p [bar _g] S/G/L	3	-	3	3	3	3	3	3	3	3	3	-
Min. set pressure low press. bellows	p [bar _g] S/G/L	2,00	-	0,98	1,41	1,11	1,81	1,50	1,05	1,18	1,41	-	-
Maximum set pressure	p [bar _g] S/G/L	16	-	16	16	16	16	16	16	16	16	16	-
Max. set pressure with special spring	p [bar _g] S/G/L	16	-	16	16	16	16	16	16	16	16	16	-
Temperature acc. to DIN EN	min. [°C]	-10	-	-10									-
	max. [°C]	+300	-	+300									-
Temperature acc. to ASME	min. [°C]	-	-	-									-
	max. [°C]	-	-	-									-

Body material: 0.7043 (ductile Gr. 60-40-18)													
DIN Flange	Inlet	-	-	PN 40						PN 16		PN 25	
	Outlet	-	-	PN 16						PN 16		PN 10	
Minimum set pressure	p [bar _g] S/G/L	-	-	0,1	0,1	0,1	0,1	0,1	0,1	0,1	0,1	0,1	0,1
Min. set pressure¹⁾ standard bellows	p [bar _g] S/G/L	-	-	3	3	3	3	3	3	3	3	3	3
Min. set pressure low press. bellows	p [bar _g] S/G/L	-	-	0,98	1,41	1,11	1,81	1,50	1,05	1,18	1,41	-	-
Maximum set pressure	p [bar _g] S/G/L	-	-	40	40	40	40	40	32	40	16	16	20
Max. set pressure with special spring	p [bar _g] S/G/L	-	-	40	40	40	40	40	40	40	16	16	25
Temperature acc. to DIN EN	min. [°C]	-	-	-60									-
	max. [°C]	-	-	+350									-
Temperature acc. to ASME	min. [°C]	-	-	-10									-
	max. [°C]	-	-	+350									-

¹⁾ Min. set pressure standard bellows = Max. set pressure low pressure bellows.

Pressure temperature ratings

Metric Units

DN _I	20	20	25	32	40	50	65	80	100	125	150	200
DN _O	32	40	40	50	65	80	100	125	150	200	250	300
Actual Orifice diameter d ₀ [mm]	18	18	23	29	37	46	60	74	92	98	125	165
Actual Orifice area A ₀ [mm ²]	254	254	416	661	1075	1662	2827	4301	6648	7543	12272	21382

Body material: 1.0619 (WCB)

DIN Flange	Inlet	-	PN 40										PN 25	
			PN 16											
Minimum set pressure	p [bar _g]	S/G/L	-	0,1	0,1	0,1	0,1	0,1	0,1	0,1	0,1	0,1	0,1	0,1
Min. set pressure ¹⁾ standard bellows	p [bar _g]	S/G/L	-	3	3	3	3	3	3	3	3	3	3	3
Min. set pressure low press. bellows	p [bar _g]	S/G/L	-	2,00	0,98	1,41	1,11	1,81	1,50	1,05	1,18	1,41	-	-
Maximum set pressure	p [bar _g]	S/G/L	-	40	40	40	40	40	40	32	40	28	17	20
Max. set pressure with special spring	p [bar _g]	S/G/L	-	40	40	40	40	40	40	40	40	28	25	25
Temperature acc. to DIN EN	min. [°C]	-	-85											
	max. [°C]	-	+450											
Temperature acc. to ASME	min. [°C]	-	-29											
	max. [°C]	-	+427											

Body material: 1.4408 (CF8M)

DIN Flange	Inlet	-	-	PN 40										-
				PN 16										
Minimum set pressure	p [bar _g]	S/G/L	-	-	0,1	0,1	0,1	0,1	0,1	0,1	0,1	0,1	0,1	-
Min. set pressure ¹⁾ standard bellows	p [bar _g]	S/G/L	-	-	3	3	3	3	3	3	3	3	3	-
Min. set pressure low press. bellows	p [bar _g]	S/G/L	-	-	0,98	1,41	1,11	1,81	1,50	1,05	1,18	1,41	-	-
Maximum set pressure	p [bar _g]	S/G/L	-	-	40	40	40	33	28	13,6	15	15	7	-
Max. set pressure with special spring	p [bar _g]	S/G/L	-	-	40	40	40	37	28	25	26	24	10	-
Temperature acc. to DIN EN	min. [°C]	-	-	-270										
	max. [°C]	-	-	+400										
Temperature acc. to ASME	min. [°C]	-	-	-268										
	max. [°C]	-	-	+538										

¹⁾ Min. set pressure standard bellows = Max. set pressure low pressure bellows.

Pressure temperature ratings

US Units

	DN _i	20	20	25	32	40	50	65	80	100	125	150	200	
	DN _o	32	40	40	50	65	80	100	125	150	200	250	300	
Actual Orifice diameter d ₀ [inch]		0,71	0,71	0,91	1,14	1,46	1,81	2,36	2,91	3,62	3,86	4,92	6,5	
Actual Orifice area A ₀ [inch ²]		0,394	0,394	0,644	1,024	1,667	2,576	4,383	6,666	10,304	11,691	19,021	33,142	
Body material: 0.6025 (cast iron)														
DIN Flange	Inlet	PN 16	-	PN 16										-
	Outlet	PN 16	-	PN 16										-
Minimum set pressure	p [psig] S/GL	1,5	-	1,5	1,5	1,5	1,5	1,5	1,5	1,5	1,5	1,5	-	
Min. set pressure ¹⁾ standard bellows	p [psig] S/GL	43,5	-	43,5	43,5	43,5	43,5	43,5	43,5	43,5	43,5	43,5	-	
Min. set pressure low press. bellows	p [psig] S/GL	29	-	14	20	16	26	22	15	17	20	-	-	
Maximum set pressure	p [psig] S/GL	232	-	232	232	232	232	232	232	232	232	232	-	
Max. set pressure with special spring	p [psig] S/GL	232	-	232	232	232	232	232	232	232	232	232	-	
Temperature acc. to DIN EN	min. [°F]	+14	-	+14										-
	max. [°F]	+572	-	+572										-
Temperature acc. to ASME	min. [°F]	-	-	-										-
	max. [°F]	-	-	-										-

Body material: 0.7043 (ductile Gr. 60-40-18)														
DIN Flange	Inlet	-	-	PN 40							PN 16		PN 25	
	Outlet	-	-	PN 16							PN 16		PN 10	
Minimum set pressure	p [psig] S/GL	-	-	1,5	1,5	1,5	1,5	1,5	1,5	1,5	1,5	1,5	1,5	
Min. set pressure ¹⁾ standard bellows	p [psig] S/GL	-	-	43,5	43,5	43,5	43,5	43,5	43,5	43,5	43,5	43,5	43,5	
Min. set pressure low press. bellows	p [psig] S/GL	-	-	14	20	16	26	22	15	17	20	-	-	
Maximum set pressure	p [psig] S/GL	-	-	580	580	580	580	580	464	580	232	232	290	
Max. set pressure with special spring	p [psig] S/GL	-	-	580	580	580	580	580	580	580	232	232	363	
Temperature acc. to DIN EN	min. [°F]	-	-	-76										
	max. [°F]	-	-	+662										
Temperature acc. to ASME	min. [°F]	-	-	+14										
	max. [°F]	-	-	+662										

¹⁾ Min. set pressure standard bellows = Max. set pressure low pressure bellows.

Pressure temperature ratings

US Units

DN _I	20	20	25	32	40	50	65	80	100	125	150	200
DN _O	32	40	40	50	65	80	100	125	150	200	250	300
Actual Orifice diameter d ₀ [inch]	0,71	0,71	0,91	1,14	1,46	1,81	2,36	2,91	3,62	3,86	4,92	6,5
Actual Orifice area A ₀ [inch ²]	0,394	0,394	0,644	1,024	1,667	2,576	4,383	6,666	1,304	11,691	19,021	33,142

Body material: 1.0619 (WCB)

DIN Flange	Inlet		PN 40											PN 25	
	Outlet		PN 16												
Minimum set pressure	p [psig]	S/GL	-	1,5	1,5	1,5	1,5	1,5	1,5	1,5	1,5	1,5	1,5	1,5	1,5
Min. set pressure ¹⁾ standard bellows	p [psig]	S/GL	-	43,5	43,5	43,5	43,5	43,5	43,5	43,5	43,5	43,5	43,5	43,5	43,5
Min. set pressure low press. bellows	p [psig]	S/GL	-	29	14	20	16	26	22	15	17	20	-	-	-
Maximum set pressure	p [psig]	S/GL	-	580	580	580	580	580	580	464	580	406	247	290	-
Max. set pressure with special spring	p [psig]	S/GL	-	580	580	580	580	580	580	580	580	406	363	363	-
Temperature acc. to DIN EN	min. [°F]		-	-121											
	max. [°F]		-	+842											
Temperature acc. to ASME	min. [°F]		-	-20											
	max. [°F]		-	+800											

Body material: 1.4408 (CF8M)

DIN Flange	Inlet		PN 40											-	
	Outlet		PN 16												
Minimum set pressure	p [psig]	S/GL	-	-	1,5	1,5	1,5	1,5	1,5	1,5	1,5	1,5	1,5	1,5	-
Min. set pressure ¹⁾ standard bellows	p [psig]	S/GL	-	-	43,5	43,5	43,5	43,5	43,5	43,5	43,5	43,5	43,5	43,5	-
Min. set pressure low press. bellows	p [psig]	S/GL	-	-	14	20	16	26	22	15	17	20	-	-	-
Maximum set pressure	p [psig]	S/GL	-	-	580	580	580	479	406	197	218	218	102	-	-
Max. set pressure with special spring	p [psig]	S/GL	-	-	580	580	580	537	406	363	377	348	145	-	-
Temperature acc. to DIN EN	min. [°F]		-	-	-454										
	max. [°F]		-	-	+752										
Temperature acc. to ASME	min. [°F]		-	-	-450										
	max. [°F]		-	-	+1000										

¹⁾ Min. set pressure standard bellows = Max. set pressure low pressure bellows.

Flange drillings

Type 441, 442 DIN

Flange drillings															
	DN _i	20	20	25	32	40	50	65	80	100	125	150	200		
	DN _O	32	40	40	50	65	80	100	125	150	200	250	300		
	Valve size	–	¾" x 1½"	1" x 1½"	1" x 2"	1" x 2½"	2" x 3"	2" x 4"	3" x 5"	4" x 6"	5" x 8"	6" x 10"	8" x 12"		
	Actual Orifice diameter d ₀ [mm]	18	18	23	29	37	46	60	74	92	98	125	165		
	Actual Orifice area A ₀ [mm ²]	254	254	416	661	1075	1662	2827	4301	6648	7543	12272	21382		
Body material: 0.6025 (cast iron)															
Inlet	DIN EN 1092	PN 10	*	*	*	*	*	*	*	*	*	*	*		
		PN 16	*	*	*	*	*	*	*	*	*	*	*		
		PN 25	–	–	–	–	–	–	–	–	–	–	–		
		PN 40	–	–	–	–	–	–	–	–	–	–	–		
Outlet	DIN EN 1092	PN 10	*	*	*	*	*	*	*	*	H50	H50			
		PN 16	*	*	*	*	*	*	*	*	*	*	*		
		PN 25	–	–	–	–	–	–	–	–	–	–	–		
		PN 40	–	–	–	–	–	–	–	–	–	–	–		
Body material: 0.7043 (ductile Gr. 60-40-18)															
Inlet	DIN EN 1092	PN 10			*	*	*	*	H45	*	H45	*	*	H44	
		PN 16			*	*	*	*	*	*	*	*	*	H45	
		PN 25			–	–	–	–	–	–	–	–	–	*	
		PN 40			–	–	–	–	–	–	–	–	–	–	
Outlet	DIN EN 1092	PN 10			*	*	*	*	*	*	H50	H50	*		
		PN 16			*	*	*	*	*	*	*	*	(H51)		
		PN 25			*	(*)	(H15)	(*)	–	–	–	–	–		
		PN 40			*	(*)	(H15)	(*)	–	–	–	–	–		
Body material: 1.0619 (WCB), 1.4408 (CF8M)															
Inlet	DIN EN 1092	PN 10			*	*	*	*	H45	H45	H45	H45	H45	H44	
		PN 16			*	*	*	*	H45	H45	H45	H45	H45	H44	
		PN 25			*	*	*	*	*	*	*	*	*	*	
		PN 40			*	*	*	*	*	*	*	*	*	*	
	ASME B16.5 ¹⁾	CL150			H64	H64	H64	H64	H64	H64	H64	[H64]	H64	H64	H64
		CL300			–	–	H65	–	[H65]	–	–	–	–	–	–
Outlet	DIN EN 1092	PN 10			*	*	*	*	*	*	H50	H50	H50		
		PN 16			*	*	*	*	*	*	*	*	*		
		PN 25			*	*	*	(H15)	(*)	–	–	–	–	H52	
		PN 40			*	*	*	(H15)	(*)	–	–	–	–	H52	
	ASME B16.5 ¹⁾	CL150			H79	H79	H79	H79	H79	[H79]	H79	H79	H79	H79	
		CL300			–	–	[H80]	–	–	–	–	–	–	–	

For signs and symbols refer to page 00/07

Note: Flange drillings and facings meet always the requirements of mentioned flange standards. Flange thickness and outer diameter may vary from flange standard.

¹⁾ For drillings according to ASME B16.5 please use preferred Type 441, 442 ANSI.

Flange facings

Flange facings										
Indication	Standard	Nozzle	Outlet		Remark					
General										
Flange undrilled	–	H38	H39							
Linde-V-Nut, Form V48	Linde Standard 420-08	J07	J08		Groove: Rz 16					
Linde-V-Nut, Form V48A	LWN 313.36	J05	J06		Groove: Rz 4, e.g. with hydrogen					
Lens seal form L (without sealing lens)	DIN 2696 LWN 313.35	J11	J12							
Acc. to DIN EN										
Flange facing			Inlet		Outlet		Remark			
DIN EN 1092 (new)		DIN 2526 (old)	PN 10 – PN 40		PN 10 – PN 40		Rz-data according to DIN EN 1092 in µm			
(see also LWN 313.40)										
Raised face	Type B1	Type C	*		*		Facing: Rz = 12,5 – 50			
	Type B2	Type D								
Tongue face C ¹⁾		Tongue face F	L36		L38		Facing: Rz = 3,2 – 12,5			
Groove face D ¹⁾		Groove face N	L94		L92		Steel flanges only			
Male face E		Male face V13	H93		H91					
Female face F		Female face R13	H96		H98					
O-ring male face G		Male face V14	H96		H99					
O-ring female face H		Female face R14	J01		J02					
			J03		J04					
Acc. to ASME B16.5										
Body material	Inlet	Outlet	Smooth finish ²⁾		Serrated finish		RTJ-groove			
			Inlet	Outlet	Inlet	Outlet	Inlet		Outlet	
			Option code	Option code	Option code	Option code	RTJ-Class	Option code	RTJ-Class	Option code
1.0619, 1.4408	all	all	L51	L53	*	*	CL150	H62	CL150	H63

¹⁾ According to DIN EN 1092 groove depths and tongue heights increased compared to the formerly valid DIN (refer to LWN 313.40). LESER manufactures the groove at flanged valves by milling. If a customer demands a turned surface in the soil of the groove according to DIN 2512 and/or DIN EN 1092-1 an additional option code is necessary: "S01: bottom of the groove drilled". Groove and tongue for PN160 flanges refer to DIN 2512/LWN 313.32.

²⁾ Smooth finish is not defined in the effective standards. For LESER's definition for smooth finish see page 00/07.

For signs and symbols refer to page 00/07

Note: Flange drillings and facings meet always the requirements of mentioned flange standards. Flange thickness and outer diameter may vary from flange standard.

Order information – Spare parts

Spare parts

	DN _i	20	20	25	32	40	50	65
	DN _o	32	40	40	50	65	80	100
	Actual Orifice diameter d ₀ [mm]	18	18	23	29	37	46	60
	Actual Orifice area A ₀ [mm ²]	254	254	416	661	1075	1662	2827
Disc (Item 7): Metal to metal seat								
Material-No. / Art.-No.								
Disc	1.4122	210.7039.9000	210.9739.9000	210.9839.9000	210.9939.9000	210.8739.9000	220.1639.9000	
detachable lifting aid	1.4404	–	210.9749.9000	210.9849.9000	210.9949.9000	210.8749.9000	220.1649.9000	
Disc (Item 7): Soft seal								
Material-No. / Art.-No.								
Disc	CR	"K"	200.4939.9051	200.5049.9051	200.5149.9051	200.5249.9051	200.5349.9051	200.5449.9051
	EPDM	"D"	200.4939.9041	200.5049.9041	200.5149.9041	200.5249.9041	200.5349.9041	200.5449.9041
	FKM	"L"	200.4939.9071	200.5049.9071	200.5149.9071	200.5249.9071	200.5349.9071	200.5449.9071
	FFKM	"C"	200.4939.9091	200.5049.9091	200.5149.9091	200.5249.9091	200.5349.9091	on request
O-ring (Item 7.4): Soft seal								
Material-No. / Art.-No.								
O-ring	CR	"K"	502.0171.2651	502.0249.3551	502.0313.3551	502.0408.3551	502.0503.3551	502.0660.5351
	EPDM	"D"	502.0171.2641	502.0249.3541	502.0313.3541	502.0408.3541	502.0503.3541	502.0660.5341
	FKM	"L"	502.0171.2671	502.0249.3571	502.0313.3571	502.0408.3571	502.0503.3571	502.0660.5371
	FFKM	"C"	502.0171.2691	502.0249.3591	502.0313.3591	502.0408.3591	502.0503.3591	on request
Bellows (Item 15): 1.4571								
Material-No. / Art.-No.								
Standard bellows			400.0149.0000	400.0949.0000	400.1049.0000	400.1149.0000	400.1249.0000	400.1349.0000
Conversion kit standard¹⁾			5021.1040	5021.1041	5021.1042	5021.1043	5021.1044	5021.1045
Low pressure bellows			400.0149.0021	400.0949.0021	400.1049.0021	400.1149.0021	400.1249.0021	400.1349.0021
Conversion kit low pressure¹⁾			please specify in writing					
Gasket – Body / bonnet (Item 60)								
Material-No. / Art.-No.								
Gasket	Graphite + 1.4401		500.0407.0000	500.0607.0000	500.0807.0000	500.1007.0000	500.1207.0000	500.1607.0000
Option code L68	Gylon (filled PTFE)		500.0405.0000	500.0605.0000	500.0805.0000	500.1005.0000	500.1205.0000	500.1605.0000
Ball (Item 61)								
Material-No. / Art.-No.								
Ball	Ball Ø [mm]		6	6	6	9	9	12
	1.4404		510.0104.0000	510.0104.0000	510.0104.0000	510.0204.0000	510.0204.0000	510.0304.0000
Split ring (Item 14)								
Material-No. / Art.-No.								
Split ring	Spindle Ø [mm]		12	12	16	16	16	20
	1.4404		251.0149.0000	251.0149.0000	251.0249.0000	251.0249.0000	251.0249.0000	251.0349.0000
Pin (Item 57)								
Material-No. / Art.-No.								
Pin	1.4310		480.0505.0000	480.0505.0000	480.0705.0000	480.0705.0000	480.0705.0000	480.1005.0000

¹⁾ For pressure range see page 01/12 – 01/15.
A conversion kit contains the following components:

Item	Component	No.
8	Guide	1
11	Bonnet spacer	1
12	Spindle	1
15	Bellows	1
55	Stud	4
60	Gasket	3
	Installation instruction LWN 037.05	1

Refer to page 01/04

Order information – Spare parts

Spare parts							
	DN _i	80	100	125	150	200	
	DN _o	125	150	200	250	300	
	Actual Orifice diameter d ₀ [mm]	74	92	98	125	165	
	Actual Orifice area A ₀ [mm ²]	4301	6648	7543	12272	21382	
Disc (Item 7): Metal to metal seat				Material-No. / Art.-No.			
Disc	1.4122	220.1739.9000	220.1839.9000	220.0439.9000	220.1949.9000	–	
detachable lifting aid	1.4404	220.1749.9000	220.1849.9000	220.0449.9000	220.1949.9000	230.1549.9000	
Disc (Item 7): Soft seal				Material-No. / Art.-No.			
Disc	CR	“K”	200.5549.9051	on request	on request	on request	–
	EPDM	“D”	200.5549.9041	200.5649.9041	200.5749.9041	200.5849.9041	–
	FKM	“L”	200.5549.9071	200.5649.9071	200.5749.9071	on request	–
	FFKM	“C”	on request	on request	on request	on request	–
O-ring (Item 7.4): Soft seal				Material-No. / Art.-No.			
O-ring	CR	“K”	502.0819.5351	on request	on request	on request	–
	EPDM	“D”	502.0819.5341	502.1041.5341	502.1041.5341	502.1295.5341	–
	FKM	“L”	502.0819.5371	502.1041.5371	502.1041.5371	on request	–
	FFKM	“C”	on request	on request	on request	on request	–
Bellows (Item 15): 1.4571				Material-No. / Art.-No.			
Standard bellows		400.1449.0000	400.0849.0000	400.0849.0000	400.3949.0000	400.5449.0000	
Conversion kit standard¹⁾		5021.1046	5021.1047	5021.1047	5021.1048	single parts	
Low pressure bellows		400.1449.0021	400.0849.0021	400.0849.0021	–	–	
Conversion kit low pressure¹⁾		please specify in writing			–	–	
Gasket – Body / bonnet (Item 60)				Material-No. / Art.-No.			
Gasket	Graphite + 1.4401	500.1907.0000	500.2107.0000	500.2107.0000	500.2207.0000	500.2807.0000	
	Option code L68 Gylon (filled PTFE)	500.1905.0000	500.2105.0000	500.2105.0000	500.2205.0000	500.2805.0000	
Ball (Item 61)				Material-No. / Art.-No.			
Ball	Ball Ø [mm]	12	15	15	15	18	
	1.4404	510.0304.0000	510.0404.0000	510.0404.0000	510.0404.0000	510.0505.0000	
Split ring (Item 14)				Material-No. / Art.-No.			
Split ring	Spindle Ø [mm]	24	24	24	30	35	
	1.4404	251.0449.0000	251.0449.0000	251.0449.0000	251.0549.0000	251.1949.0000	
Pin (Item 57)				Material-No. / Art.-No.			
Pin	1.4310	480.1005.0000	480.1105.0000	480.1105.0000	480.1205.0000	480.1405.0000	

¹⁾ For pressure range see page 01/12 – 01/15.
A conversion kit contains the following components:

Item	Component	No.
8	Guide	1
11	Bonnet spacer	1
12	Spindle	1
15	Bellows	1
55	Stud	8, 12 depends on valve size
60	Gasket	2, 3 depends on valve size
	Installation instruction LWN 037.05	1

Refer to page 01/04

Type 441, 442 DIN

Available Options

For further information refer to "Accessories and Options", page 99/01

Heating jacket

H29, H30: Couplings G 3/8, G 3/4
H31, H32: Flanges DN 15, DN 25



Drain hole

J18: G 1/4
J19: G 1/2

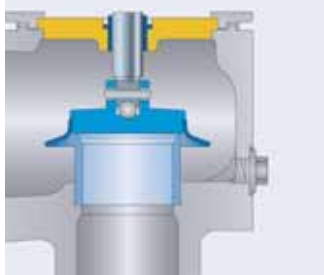

Open bonnet

See Art.-No.



O-ring-disc

J20: FFKM "C"
J21: CR "K"
J22: EPDM "D"
J23: FKM "L"

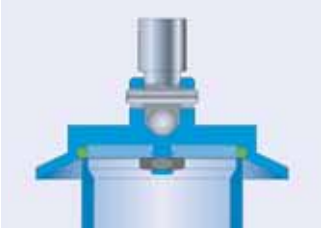

Disc with inserted sealing plate

J44: PTFE-FDA
J48: PCTFE
J49: SP

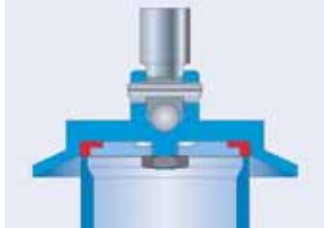

Stainless steel bellows

J68: Open bonnet
J78: Closed bonnet

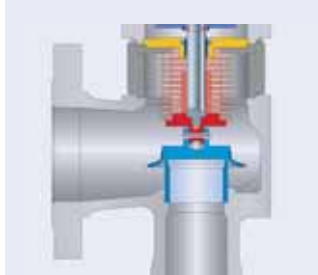

Conversion kit for stainless steel bellows

See Art.-No. page 06/15

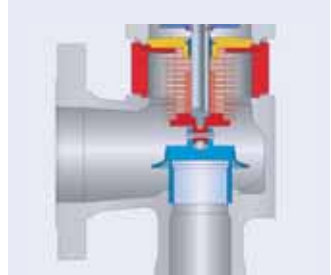

Screwed cap H2



Plain lever H3



Packed lever H4



Test gag

J69: H4
J70: H2

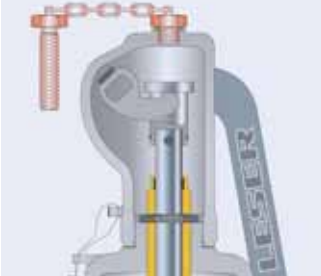

Lift indicator

J39: Adaptor H4
J93: Lift indicator



O-ring-damper H2

J65



O-ring-damper H4

J66



Approvals

Approvals		
	DN _i	20 – 200
	DN _o	32 – 300
	Actual Orifice diameter d ₀ [mm]	18 – 165
	Actual Orifice area A ₀ [mm ²]	254 – 21382
Europe		Coefficient of discharge K_{dr}
DIN EN ISO 4126-1	Approval No.	072020111Z0008/0/08-2
	S/G	0,7
	L	0,45
Germany		Coefficient of discharge α_w
AD 2000-Merkblatt A2	Approval No.	TÜV SV 576
	S/G	0,7
	L	0,45
United States		Coefficient of discharge K
ASME Sec. VIII	Approval No.	M37044
	S/G	0,699
	Approval No.	M37055
	L	0,521
Canada		Coefficient of discharge K
Canada: CRN	Approval No.	OG1182.9C
	S/G	0,699
	L	0,521
China		Coefficient of discharge α_w
CSBQTS	Approval No.	
	S/G	0,7
	L	0,45
Russia		Coefficient of discharge α_w
GGTN/ GOSGOTECHNADZOR GOST R	Approval No.	PPC 00-18458
	S/G	0,7
	L	0,45
Classification societies		Homepage
Bureau Veritas	BV	www.bureauveritas.com
Det Norske Veritas	DNV	www.dnv.com
Germanischer Lloyd	GL	www.gl-group.com
Lloyd' s register EMEA	LREMEA	www.lr.org
Registro Italiano Navale	RINA	www.rina.org
<p>The valid certification number is changed with every renewal.</p> <p>A sample certificate including the valid certification number can be taken from the homepage of the classification societies.</p>		

Capacities – Steam

Capacities for saturated steam according to AD 2000-Merkblatt A2, based on set pressure plus 10 % overpressure.
 Capacities at 1 bar (14,5 psig) and below are based on 0,1 bar (1,45 psig) overpressure.

Metric Units		AD 2000-Merkblatt A2 [kg/h]											
DN _I	20	20	25	32	40	50	65	80	100	125	150	200	
DN _O	32	40	40	50	65	80	100	125	150	200	250	300	
Actual Orifice diameter d ₀ [mm]	18	18	23	29	37	46	60	74	92	98	125	165	
Actual Orifice area A ₀ [mm ²]	254	254	416	661	1075	1662	2827	4301	6648	7543	12272	21382	
LEO _{S/G} ^{*)} [inch ²]	0,283	0,283	0,462	0,734	1,195	1,847	3,142	4,779	7,387	8,382	13,637	23,761	
Set pressure [bar]	Capacities [kg/h]												
0,1	0	0	0	0	0	0	0	0	0	0	0	0	
0,2	86	86	140	223	363	561	954	1451	2243	2545	4140	7214	
0,5	137	137	224	356	579	895	1523	2316	3580	4062	6609	11516	
1	199	199	326	518	843	1302	2215	3370	5209	5910	9616	16755	
2	318	318	519	825	1343	2075	3531	5371	8302	9420	15326	26704	
3	428	428	699	1111	1808	2794	4754	7232	11178	12683	20635	35954	
4	534	534	871	1385	2254	3485	5928	9018	13938	15816	25731	44834	
5	639	639	1043	1658	2699	4172	7097	10796	16687	18934	30804	53673	
6	744	744	1214	1930	3142	4856	8262	12568	19426	22042	35861	62484	
7	846	846	1381	2196	3574	5525	9399	14297	22098	25074	40794	71080	
8	950	950	1551	2466	4014	6205	10556	16057	24818	28161	45816	79830	
9	1054	1054	1721	2736	4454	6884	11712	17815	27535	31244	50831	88569	
10	1158	1158	1891	3006	4893	7562	12866	19571	30250	34324	55842	97300	
12	1366	1366	2230	3545	5770	8919	15174	23081	35675	40480	65858	114751	
14	1569	1569	2562	4073	6629	10247	17433	26518	40987	46507	75664	131837	
16	1776	1776	2900	4610	7505	11600	19735	30020	46400	52650	85657	149249	
18	1984	1984	3239	5149	8382	12955	22041	33526	51820	58800	95663	166683	
20	2191	2191	3578	5688	9260	14312	24350	37039	57249	64960	105685	184145	
22	2393	2393	3907	6212	10111	15629	26590	40446	62515	70935	115407	201085	
24	2601	2601	4247	6752	10991	16988	28903	43964	67953	77106	125445	218576	
26	2810	2810	4588	7294	11873	18351	31222	47491	73405	83292			
28	3019	3019	4930	7837	12757	19718	33547	51029	78873	89496			
30	3229	3229	5272	8382	13644	21089	35880	54577	84358				
32	3440	3440	5616	8929	14534	22465	38220	58137	89860				
34	3641	3641	5945	9451	15384	23779	40455	61537	95115				
36	3853	3853	6290	10000	16278	25160	42806	65112	100641				
38	4065	4065	6637	10551	17175	26547	45165	68701	106188				
40	4278	4278	6985	11104	18076	27939	47533	72303	111756				

^{*)} LEO_{S/G} = LESER Effective Orifice steam/gas please refer to page 00/11
 How to use capacity-sheets refer to page 00/09

Capacities – Steam

Capacities for saturated steam according to ASME Section VIII (UV), based on set pressure plus 10% overpressure.
 Capacities at 2,07 bar (30 psig) and below are based on 0,207 bar (3 psig) overpressure.

US Units		ASME Section VIII [lb/ h]											
DN _i	20	20	25	32	40	50	65	80	100	125	150	200	
DN _o	32	40	40	50	65	80	100	125	150	200	250	300	
Actual Orifice diameter d ₀ [inch]	0,71	0,71	0,91	1,14	1,46	1,81	2,36	2,91	3,62	3,86	4,92	6,5	
Actual Orifice area A ₀ [inch ²]	0,394	0,394	0,644	1,024	1,667	2,576	4,383	6,666	10,304	11,691	19,021	33,142	
LEO _{S/G} ^{*)} [inch ²]	0,283	0,283	0,462	0,734	1,195	1,847	3,142	4,779	7,387	8,382	13,637	23,761	
Set pressure [psig]	Capacities [lb/h]												
15			757	1204	1959	3028	5152	7837	12113	13744	22361	38962	
20			873	1388	2259	3492	5941	9037	13968	15849	25785	44928	
30			1105	1756	2859	4419	7519	11436	17677	20058	32632	56859	
40			1360	2162	3519	5439	9254	14076	21757	24687	40165	69983	
50			1615	2567	4179	6459	10989	16716	25837	29317	47697	83107	
60			1870	2973	4839	7479	12725	19356	29917	33947	55229	96231	
70			2125	3378	5499	8499	14460	21995	33997	38576	62761	109355	
80			2380	3783	6159	9519	16196	24635	38078	43206	70293	122479	
90			2635	4189	6819	10539	17931	27275	42158	47836	77825	135603	
100			2890	4594	7479	11559	19666	29915	46238	52466	85357	148727	
120			3400	5405	8799	13600	23137	35194	54398	61725	100422	174975	
140			3910	6216	10118	15640	26608	40474	62558	70984	115486	201223	
160			4420	7027	11438	17680	30079	45753	70719	80244	130550	227471	
180			4930	7838	12758	19720	33550	51033	78879	89503	145615	253719	
200			5440	8648	14078	21760	37020	56312	87039	98762	160679	279967	
220			5950	9459	15398	23800	40491	61592	95200	108022	175743	306215	
240			6460	10270	16718	25840	43962	66871	103360	117281	190808	332463	
260			6970	11081	18038	27880	47433	72151	111520	126540	205872	358711	
280			7480	11892	19358	29920	50904	77430	119680	135800	220936	384960	
300			7990	12703	20677	31960	54375	82710	127841	145059	236001	411208	
320			8500	13513	21997	34000	57845	87989	136001	154319	251065	437456	
340			9010	14324	23317	36040	61316	93269	144161	163578	266129	463704	
360			9520	15135	24637	38080	64787	98548	152321	172837	281194	489952	
380			10030	15946	25957	40120	68258	103828	160482	182097			
400			10540	16757	27277	42161	71729	109107	168642	191356			
420			11050	17567	28597	44201	75199	114387	176802				
440			11560	18378	29917	46241	78670	119666	184963				
460			12070	19189	31236	48281	82141	124946	193123				
480			12580	20000	32556	50321	85612	130225	201283				
500			13090	20811	33876	52361	89083	135505	209443				
550			14365	22838	37176	57461	97760	148704	229844				
580			15130	24054	39156	60521	102966	156623	242085				

Please select DN_i 25

^{*)} LEO_{S/G} = LESER Effective Orifice steam/gas please refer to page 00/11
 How to use capacity-sheets refer to page 00/09

Capacities – Air

Capacities for air according to AD 2000-Merkblatt A2, based on set pressure plus 10 % overpressure at 0 °C and 1013 mbar.
 Capacities at 1 bar (14,5 psig) and below are based on 0,1 bar (1,45 psig) overpressure.

Metric Units		AD 2000-Merkblatt A2 [m_n^3/h]											
DN _I	20	20	25	32	40	50	65	80	100	125	150	200	
DN _O	32	40	40	50	65	80	100	125	150	200	250	300	
Actual Orifice diameter d ₀ [mm]	18	18	23	29	37	46	60	74	92	98	125	165	
Actual Orifice area A ₀ [mm ²]	254	254	416	661	1075	1662	2827	4301	6648	7543	12272	21382	
LEO _{S/G} ^{*)} [inch ²]	0,283	0,283	0,462	0,734	1,195	1,847	3,142	4,779	7,387	8,382	13,637	23,761	
Set pressure [bar]	Capacities [m_n^3/h]												
0,1	0	0	0	0	0	0	0	0	0	0	0	0	
0,2	99	99	162	258	420	649	1105	1680	2597	2947	4794	8354	
0,5	161	161	263	418	680	1051	1789	2721	4206	4772	7764	13528	
1	238	238	388	617	1004	1552	2641	4017	6209	7045	11461	19970	
2	384	384	627	996	1622	2507	4265	6487	10026	11377	18509	32251	
3	523	523	854	1357	2209	3414	5809	8836	13657	15497	25212	43930	
4	656	656	1071	1703	2773	4286	7291	11091	17143	19452	31647	55142	
5	790	790	1289	2050	3337	5157	8774	13346	20629	23407	38082	66354	
6	923	923	1507	2396	3900	6029	10257	15601	24114	27362	44516	77565	
7	1057	1057	1725	2742	4464	6900	11739	17857	27600	31317	50951	88777	
8	1190	1190	1943	3089	5028	7771	13222	20112	31086	35273	57386	99989	
9	1323	1323	2161	3435	5592	8643	14704	22367	34571	39228	63821	111201	
10	1457	1457	2379	3781	6155	9514	16187	24622	38057	43183	70255	122413	
12	1724	1724	2814	4474	7283	11257	19152	29132	45028	51093	83125	144836	
14	1991	1991	3250	5167	8411	13000	22117	33642	52000	59003	95994	167260	
16	2257	2257	3686	5859	9538	14743	25082	38153	58971	66914	108863	189684	
18	2524	2524	4121	6552	10666	16486	28047	42663	65942	74824	121733	212107	
20	2791	2791	4557	7245	11793	18228	31012	47173	72913	82734	134602	234531	
22	3058	3058	4993	7938	12921	19971	33977	51683	79885	90644	147472	256954	
24	3325	3325	5429	8630	14048	21714	36943	56194	86856	98555	160341	279378	
26	3592	3592	5864	9323	15176	23457	39908	60704	93827	106465			
28	3859	3859	6300	10016	16304	25200	42873	65214	100799	114375			
30	4125	4125	6736	10708	17431	26942	45838	69725	107770				
32	4392	4392	7171	11401	18559	28685	48803	74235	114741				
34	4659	4659	7607	12094	19686	30428	51768	78745	121713				
36	4926	4926	8043	12786	20814	32171	54733	83255	128684				
38	5193	5193	8478	13479	21941	33914	57698	87766	135655				
40	5460	5460	8914	14172	23069	35657	60663	92276	142626				

^{*)} LEO_{S/G} = LESER Effective Orifice steam/gas please refer to page 00/11
 How to use capacity-sheets refer to page 00/09

Capacities – Air

Capacities for air according to ASME Section VIII (UV), based on set pressure plus 10 % overpressure at 16 °C (60 °F).
 Capacities at 2,07 bar (30 psig) and below are based on 0,207 bar (3 psig) overpressure.

US Units		ASME Section VIII [I.S.C.F.M.]										
DN _i	20	20	25	32	40	50	65	80	100	125	150	200
DN _o	32	40	40	50	65	80	100	125	150	200	250	300
Actual Orifice diameter d ₀ [inch]	0,71	0,71	0,91	1,14	1,46	1,81	2,36	2,91	3,62	3,86	4,92	6,5
Actual Orifice area A ₀ [inch ²]	0,394	0,394	0,644	1,024	1,667	2,576	4,383	6,666	10,304	11,691	19,021	33,142
LEO _{S/G} ^{*)} [inch ²]	0,283	0,283	0,462	0,734	1,195	1,847	3,142	4,779	7,387	8,382	13,637	23,761
Set pressure [psig]	Capacities [S.C.F.M.]											
15			270	429	698	1079	1835	2792	4315	4896	7965	2780
20			311	494	805	1244	2116	3219	4976	5646	9185	3142
30			394	626	1019	1574	2679	4074	6297	7145	11624	3764
40			484	770	1254	1938	3297	5014	7750	8794	14307	4346
50			575	915	1489	2301	3915	5954	9204	10444	16990	4859
60			666	1059	1724	2664	4533	6895	10657	12093	19673	5323
70			757	1204	1959	3028	5152	7835	12111	13742	22356	5749
80			848	1348	2194	3391	5770	8775	13564	15391	25039	6146
90			939	1492	2430	3754	6388	9715	15018	17041	27722	6519
100			1029	1637	2665	4118	7006	10656	16471	18690	30406	6872
120			1211	1926	3135	4845	8243	12536	19378	21988	35772	7528
140			1393	2215	3605	5571	9479	14417	22285	25287	41138	8131
160			1574	2504	4076	6298	10716	16298	25192	28585	46504	8692
180			1756	2792	4546	7025	11952	18178	28099	31884	51870	9220
200			1938	3081	5016	7751	13189	20059	31006	35182	57236	9718
220			2120	3369	5486	8478	14425	21939	33913	38481	62602	10193
240			2301	3659	5957	9205	15662	23820	36820	41779	67968	10646
260			2483	3948	6427	9932	16898	25700	39727	45078	73334	11081
280			2665	4237	6897	10658	18135	27581	42633	48376	78701	11499
300			2846	4526	7368	11385	19371	29462	45540	51675	84067	11902
320			3028	4815	7838	12112	20608	31342	48447	54973	89433	12293
340			3210	5104	8308	12839	21844	33223	51354	58272	94799	12671
360			3391	5392	8778	13565	23081	35103	54261	61570	100165	13039
380			3573	5681	9249	14292	24317	36984	57168	64869		
400			3755	5970	9719	15019	25554	38864	60075	68167		
420			3936	6259	10189	15745	26791	40745	62982			
440			4118	6548	110660	16472	28027	42626	65889			
460			4300	6837	11130	17199	29264	44506	68796			
480			4481	7126	11600	17926	30500	46387	71703			
500			4663	7415	12070	18652	31737	48267	74610			
550			5117	8137	13246	20469	34828	52969	81877			
580			5390	8570	13952	21559	36683	55790	86237			

 Please select DN_i 25

^{*)} LEO_{S/G} = LESER Effective Orifice steam/gas please refer to page 00/11
 How to use capacity-sheets refer to page 00/09

Capacities – Water

Capacities for water according to AD 2000-Merkblatt A2, based on set pressure plus 10 % overpressure at 20 °C (68 °F).
 Capacities at 1 bar (14,5 psig) and below are based on 0,1 bar (1,45 psig) overpressure.

Metric Units		AD 2000-Merkblatt A2 [10^3kg/h]											
DN _I		20	20	25	32	40	50	65	80	100	125	150	200
DN _O		32	40	40	50	65	80	100	125	150	200	250	300
Actual Orifice diameter d ₀ [mm]		18	18	23	29	37	46	60	74	92	98	125	165
Actual Orifice area A ₀ [mm ²]		254	254	416	661	1075	1662	2827	4301	6648	7543	12272	21382
LEO _L ^{*)} [inch ²]		0,316	0,316	0,516	0,821	1,336	2,062	3,513	5,343	8,259	9,371	15,246	26,565
Set pressure [bar]	Capacities [10^3kg/h]												
0,1	2,60	2,60	4,25	6,76	11,0	17,0	28,9	44,0	68,0	77,2	126	219	
0,2	3,19	3,19	5,21	8,28	13,5	20,8	35,5	53,9	83,3	94,6	154	268	
0,5	4,51	4,51	7,37	11,7	19,1	29,5	50,1	76,3	118	134	218	379	
1	6,11	6,11	9,97	15,9	25,8	39,9	67,9	103	160	181	295	513	
2	8,64	8,64	14,1	22,4	36,5	56,4	96,0	146	226	256	417	726	
3	10,6	10,6	17,3	27,5	44,7	69,1	118	179	276	314	510	889	
4	12,2	12,2	19,9	31,7	51,6	79,8	136	206	319	362	589	1027	
5	13,7	13,7	22,3	35,5	57,7	89,2	152	231	357	405	659	1148	
6	15,0	15,0	24,4	38,8	63,2	97,7	166	253	391	444	722	1257	
7	16,2	16,2	26,4	42,0	68,3	106	180	273	422	479	779	1358	
8	17,3	17,3	28,2	44,8	73,0	113	192	292	451	512	833	1452	
9	18,3	18,3	29,9	47,6	77,4	120	204	310	479	543	884	1540	
10	19,3	19,3	31,5	50,1	81,6	126	215	326	505	573	932	1623	
12	21,2	21,2	34,6	54,9	89,4	138	235	358	553	627	1021	1778	
14	22,9	22,9	37,3	59,3	96,6	149	254	386	597	678	1102	1921	
16	24,4	24,4	39,9	63,4	103	160	272	413	638	724	1178	2053	
18	25,9	25,9	42,3	67,3	110	169	288	438	677	768	1250	2178	
20	27,3	27,3	44,6	70,9	115	178	304	462	714	810	1317	2296	
22	28,7	28,7	46,8	74,4	121	187	318	484	748	849	1382	2408	
24	29,9	29,9	48,9	77,7	126	195	333	506	782	887	1443	2515	
26	31,1	31,1	50,9	80,9	132	203	346	526	814	923			
28	32,3	32,3	52,8	83,9	137	211	359	546	844	958			
30	33,5	33,5	54,6	86,8	141	219	372	565	874				
32	34,6	34,6	56,4	89,7	146	226	384	584	903				
34	35,6	35,6	58,2	92,5	151	233	396	602	931				
36	36,7	36,7	59,8	95,1	155	239	407	619	957				
38	37,7	37,7	61,5	97,7	159	246	418	636	984				
40	38,6	38,6	63,1	100	163	252	429	653	1009				

^{*)} LEO_L = LESER Effective Orifice liquids please refer to page 00/12
 How to use capacity-sheets refer to page 00/09

Type 441, 442 DIN



Capacities – Water

Capacities for water according to ASME Section VIII (UV), based on set pressure plus 10 % overpressure at 21 °C (70 °F).
Capacities at 2,07 bar (30 psig) and below are based on 0,207 bar (3 psig) overpressure.

US Units		ASME Section VIII [US-G.P.M.]											
DN _I		20	20	25	32	40	50	65	80	100	125	150	200
DN _O		32	40	40	50	65	80	100	125	150	200	250	300
Actual Orifice diameter d ₀ [inch]		0,71	0,71	0,91	1,14	1,46	1,81	2,36	2,91	3,62	3,86	4,92	6,5
Actual Orifice area A ₀ [inch ²]		0,394	0,394	0,644	1,024	1,667	2,576	4,383	6,666	10,304	11,691	19,021	33,142
LEO _L ^{*)} [inch ²]		0,316	0,316	0,516	0,821	1,336	2,062	3,513	5,343	8,259	9,371	15,246	26,565
Set pressure [psig]		Capacities [US-G.P.M.]											
15				54,0	85,9	140	216	368	559	864	981	1595	2780
20				61,1	97,1	158	244	416	632	977	1109	1803	3142
30				73,1	116	189	293	498	757	1170	1328	2160	3764
40				84,5	134	219	338	575	874	1351	1533	2494	4346
50				94,4	150	244	378	643	977	1511	1714	2789	4859
60				103	164	268	414	704	1071	1655	1878	3055	5323
70				112	178	289	447	760	1156	1787	2028	3300	5749
80				119	190	309	478	813	1236	1911	2168	3527	6146
90				127	201	328	507	862	1311	2027	2300	3741	6519
100				134	212	346	534	909	1382	2136	2424	3944	6872
120				146	233	379	585	996	1514	2340	2656	4320	7528
140				158	251	409	632	1075	1635	2528	2868	4666	8131
160				169	269	437	676	1150	1748	2702	3066	4989	8692
180				179	285	464	717	1219	1854	2866	3252	5291	9220
200				189	300	489	755	1285	1955	3021	3428	5577	9718
220				198	315	513	792	1348	2050	3169	3596	5850	10193
240				207	329	535	827	1408	2141	3310	3756	6110	10646
260				215	342	557	861	1465	2229	3445	3909	6359	11081
280				223	355	578	894	1521	2313	3575	4057	6599	11499
300				231	368	599	925	1574	2394	3700	4199	6831	11902
320				239	380	618	955	1626	2472	3822	4337	7055	12293
340				246	391	637	985	1676	2549	3939	4470	7272	12671
360				253	403	656	1013	1724	2622	4054	4600	7483	13039
380				260	414	674	1041	1772	2694	4165	4726		
400				267	425	691	1068	1818	2764	4273	4848		
420				274	435	708	1095	1862	2833	4378			
440				280	445	725	1120	1906	2899	4481			
460				286	455	741	1146	1949	2964	4582			
480				293	465	757	1170	1991	3028	4681			
500				299	475	773	1194	2032	3091	4777			
550				313	498	811	1253	2131	3241	5010			
580				322	511	832	1286	2189	3329	5145			

Please select DN_I 25

^{*)} LEO_L = LESER Effective Orifice liquids please refer to page 00/12
How to use capacity-sheets refer to page 00/09

Determination of coefficient of discharge in case of lift restriction or back pressure

- h = Lift [mm]
- d_0 = Flow diameter [mm] of selected safety valve, refer to table article numbers
- h/d_0 = Ratio of lift / flow diameter
- p_{a0} = Back pressure [bar_a]
- p_0 = Set pressure [bar_a]
- p_{a0}/p_0 = Ratio of back pressure / set pressure
- K_{dr} = Coefficient of discharge acc. to DIN EN ISO 4126-1
- α_w = Coefficient of discharge acc. to AD 2000-Merkblatt A2
- K_b = Back pressure correction factor acc. to API 520 topic 3.3

Diagram for evaluation of ratio of lift / flow diameter (h/d_0) in reference to the coefficient of discharge (K_{dr}/α_w)

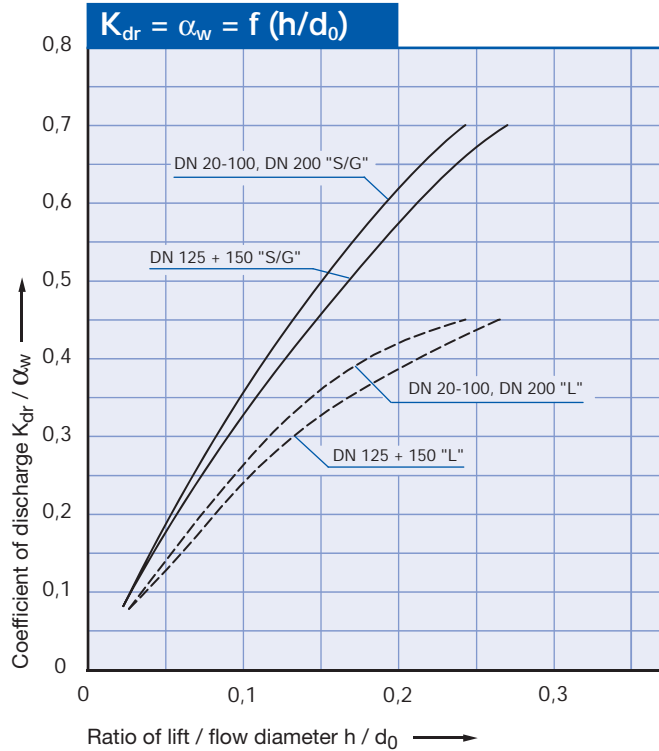
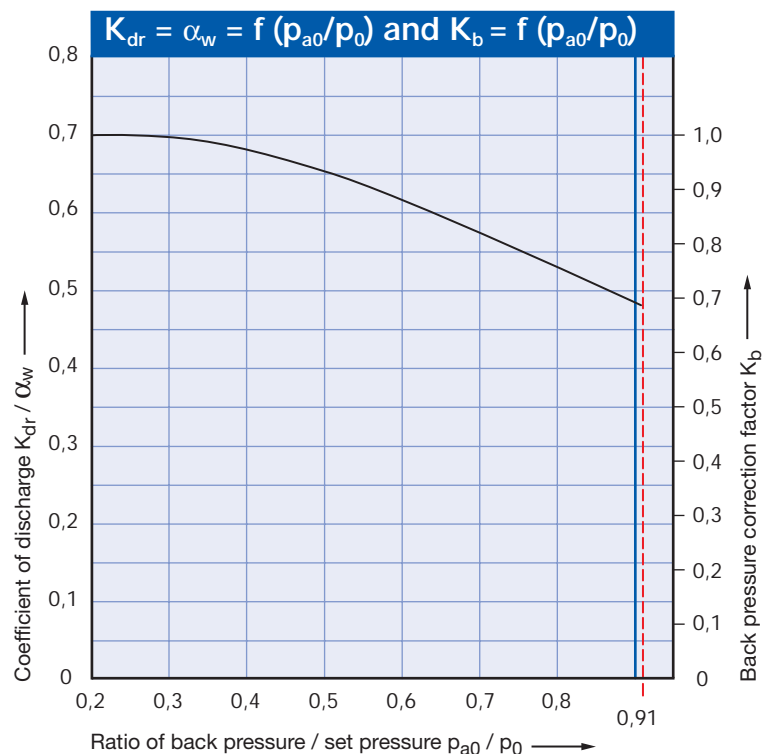

Diagram for evaluation of coefficient of discharge (K_{dr}/α_w) or K_b in reference to the ratio of back pressure / set pressure (p_{a0}/p_0)



How to use please refer to page 00/08



Type 442 ANSI
Plain lever H3
Open bonnet
Conventional design



Type 441 ANSI
Packed lever H4
Closed bonnet
Conventional design

Type 441 ANSI 442 ANSI

Flanged Safety Relief Valves – spring loaded

Type 441, 442 ANSI

Contents	Chapter/Page
Materials	
• Conventional design	02/02
• Balanced bellows design	02/04
How to order	
• Numbering system	02/06
• Article numbers	02/08
Dimensions and weights	
• Metric Units	02/10
• US Units	02/11
Pressure temperature ratings	
• Metric Units	02/12
• US Units	02/13
Flange drillings and facings	02/14
Order information – Spare parts	02/15
Available options	02/16
Approvals	02/17
Capacities	
• Steam [Metric Units + US Units]	02/18
• Air [Metric Units + US Units]	02/19
• Water [Metric Units + US Units]	02/20
Determination of coefficient of discharge K_{dr}/α_w	02/21

Conventional design

Type 441, 442 ANSI

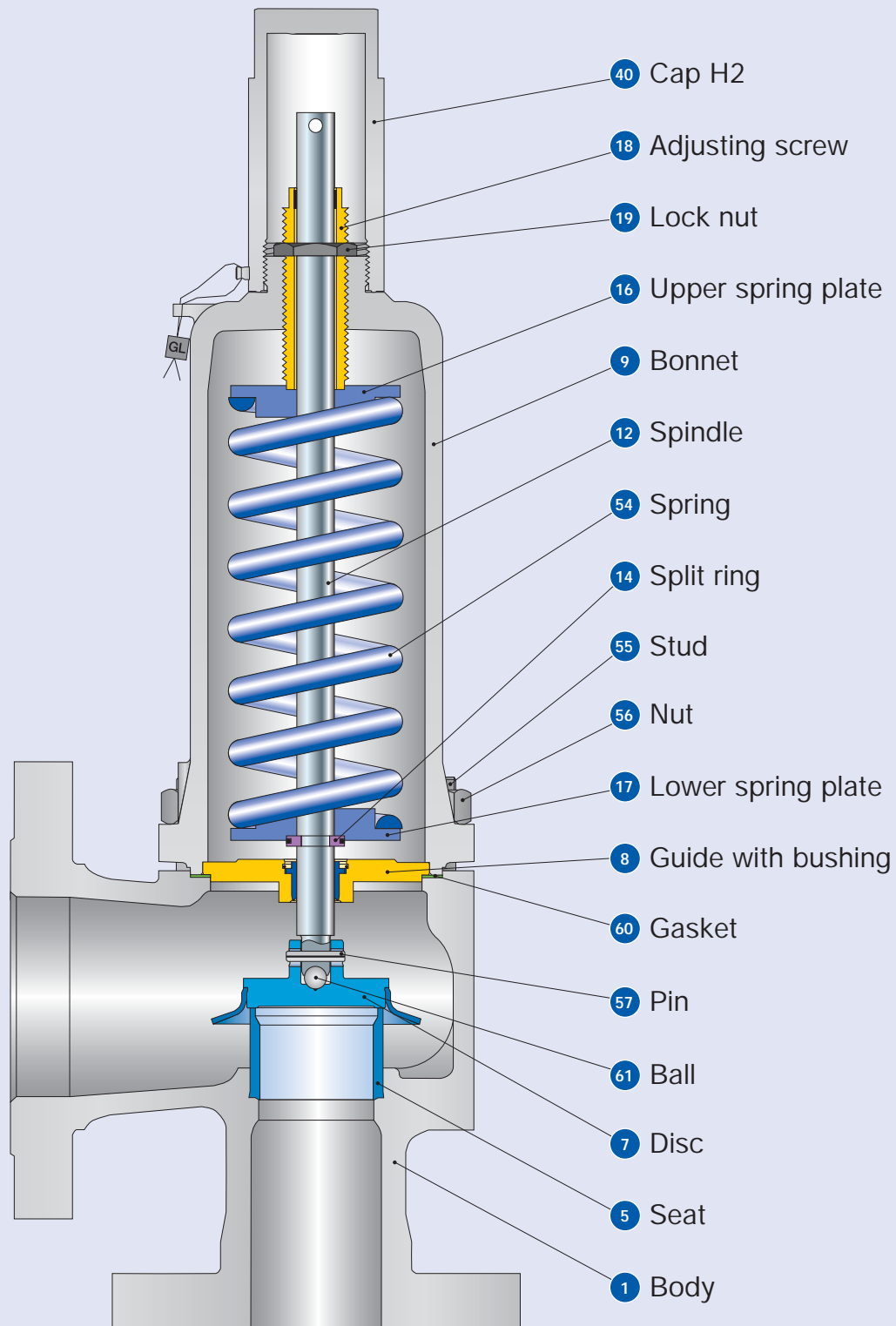

Conventional design

Materials		Type 4412 / 4422 ANSI	Type 4414 ANSI
1	Body	1.0619	1.4408
		SA 216 WCB	SA 351 CF8M
5	Seat	1.4404	1.4404
		316L	316L
7	Disc	1.4122	1.4404
		Hardened stainless steel	316L
8	Guide with bushing	1.4104, 1.0501, 0.7040	1.4404
		Chrome or carbon steel	316L
		1.4104 tenifer	-
		Chrome steel tenifer	-
9	Bonnet	0.7040, 0.7043, 1.0619	1.4408, 1.4404, 1.4571
		Ductile Gr. 60-40-18, SA 216 WCB	SA 351 CF8M, SA 479 316L, SA 479 316Ti
12	Spindle	1.4021	1.4404
		420	316L
14	Split ring	1.4104	1.4404
		Chrome steel	316L
16/17	Spring plate	1.0718	1.4404
		Steel	316L
18	Adjusting screw with bushing	1.4104 PTFE	1.4404 PTFE
		Chrome steel PTFE	316L PTFE
19	Lock nut	1.0718	1.4404
		Steel	316L
40	Cap H2	1.0718 or 0.7043	1.4404
		12L13 or Gr. 60-40-18	316L
54	Spring standard	1.1200, 1.8159, 1.7102	1.4310
		Carbon steel	Stainless steel
54	Spring optional	1.4310	-
		Stainless steel	-
55	Stud	1.1181	1.4401
		Steel	B8M
56	Nut	1.0501	1.4401
		2H	8M
57	Pin	1.4310	1.4310
		Stainless steel	Stainless steel
60	Gasket	Graphite / 1.4401	Graphite / 1.4401
		Graphite / 316	Graphite / 316
61	Ball	1.3541	1.4401
		Hardened stainless steel	316

Please notice:

- Modifications reserved by LESER.
- LESER can upgrade materials without notice.
- Every part can be replaced by other material acc. to customer specification.

Type 441, 442 ANSI

Balanced bellows design

Type 441, 442 ANSI

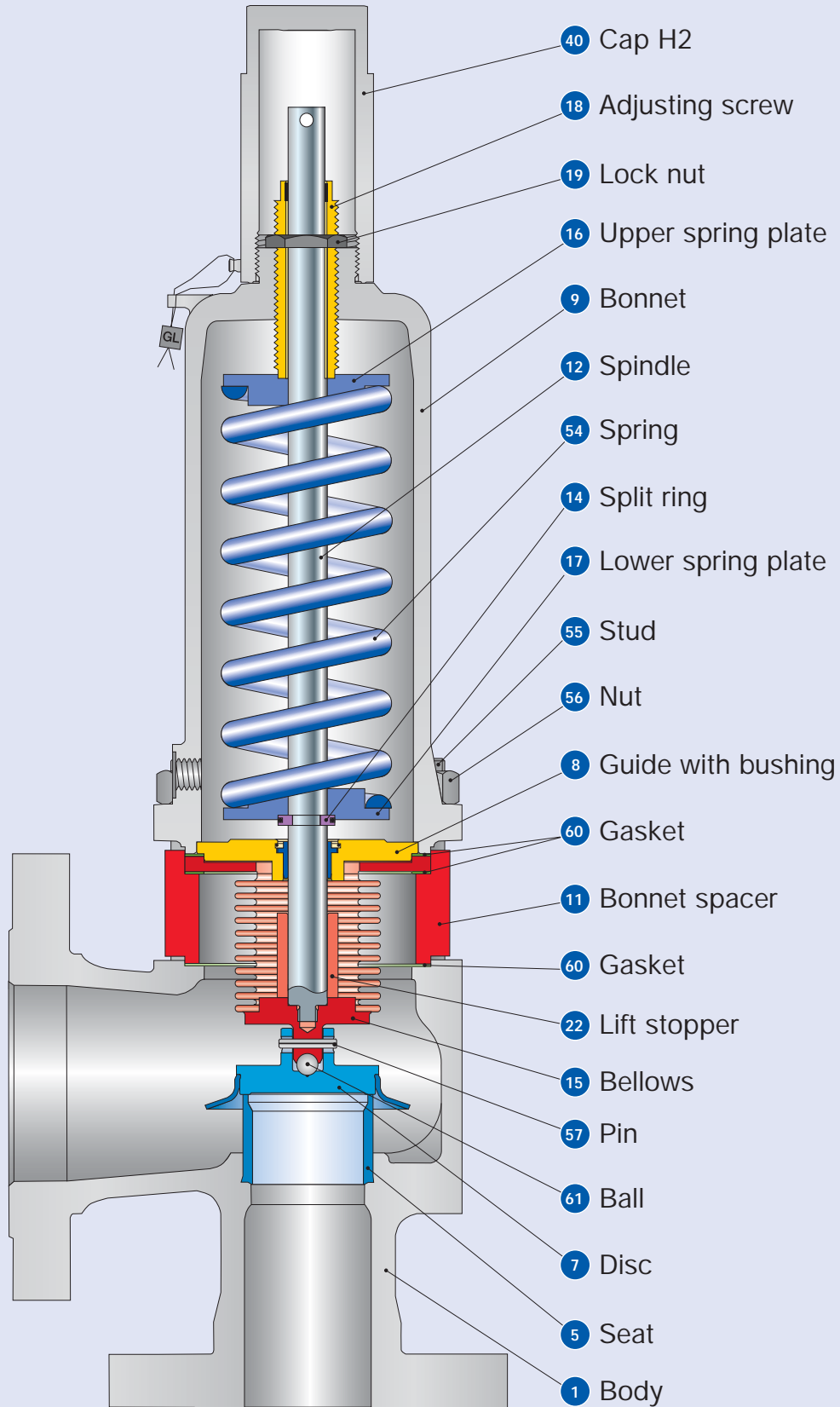

Balanced bellows design

Materials		Type 4412 / 4422 ANSI	Type 4414 ANSI
1	Body	1.0619	1.4408
		SA 216 WCB	SA 351 CF8M
5	Seat	1.4404	1.4404
		316L	316L
7	Disc	1.4122	1.4404
		Hardened stainless steel	316L
8	Guide with bushing	1.4104, 1.0501, 0.7040	1.4404
		Chrome or carbon steel	316L
		1.4104 tenifer	-
		Chrome steel tenifer	-
9	Bonnet	0.7040, 0.7043, 1.0619	1.4408, 1.4404, 1.4571
		Ductile Gr. 60-40-18, SA 216 WCB	SA 351 CF8M, SA 479 316L, SA 479 316Ti
11	Bonnet spacer	1.4404	1.4404
		316L	316L
12	Spindle	1.4404	1.4404
		316L	316L
14	Split ring	1.4104	1.4404
		Chrome steel	316L
15	Bellows	1.4571	1.4571
		316Ti	316Ti
16/17	Spring plate	1.0718	1.4404
		Steel	316L
18	Adjusting screw with bushing	1.4104 PTFE	1.4404 PTFE
		Chrome steel PTFE	316L PTFE
19	Lock nut	1.0718	1.4404
		Steel	316L
22	Lift stopper	1.4404	1.4404
		316L	316L
40	Cap H2	1.0718 or 0.7043	1.4404
		12L13 or Gr. 60-40-18	316L
54	Spring standard	1.1200, 1.8159, 1.7102	1.4310
		Carbon steel	Stainless steel
	Spring optional	1.4310	-
		Stainless steel	-
55	Stud	1.4401	1.4401
		B8M	B8M
56	Nut	1.4401	1.4401
		8M	8M
57	Pin	1.4310	1.4310
		Stainless steel	Stainless steel
60	Gasket	Graphite / 1.4401	Graphite / 1.4401
		Graphite / 316	Graphite / 316
61	Ball	1.3541	1.3541
		Hardened stainless steel	316

Please notice:

- Modifications reserved by LESER.
- LESER can upgrade materials without notice.
- Every part can be replaced by other material acc. to customer specification.

How to order – Numbering system

Type 441, 442 ANSI

1

Article Number

1	2	3	4
441	2	.481	2

1 Valve Type 441, 442 ANSI
 Type 441 – with closed bonnet
 Type 442 – with open bonnet

2

Code	Body material
2	1.0619 (WCB)
4	1.4408 (CF8M)

3 Valve code
 Identifies valve size and body material, refer to page 02/09.

4

Code	Lifting lever	
2	screwed cap	H2
3	plain lever	H3
4	packed lever	H4
5	plain lever with open bonnet	H3

4412.4812

Article No.

2

Set Pressure

Please state unit (in gauge)!

Please do not exceed the pressure range defined in the spring charts.

5 barg

Set Pressure

3

Connections

Please refer to page 02/14

H45

Connections

4 Options

Type 441, 442 ANSI	Option code
• O-ring-disc	
CR	"K" J21
EPDM	"D" J22
FKM	"L" J23
FFKM	"C" J20
• Disc 1.4404 / 316L	L44
• Disc 1.4404 / 316L stellited	J25
• Detachable lifting aid	J26
• Stainless steel bellows	
- open bonnet (Type 442)	J68
- closed bonnet (Type 441)	J78
• Elastomer bellows	J79
• High temperature alloy spring	X01
• Stainless steel spring	X04
• Adaptor for lift indicator	H4 J39
• Lift indicator	J93
• Test gag	
- cap	H2 J70
- packed lever	H4 J69
• Seat 316L stellited	L61
• Heating jacket	
- Couplings	G 3/8 H29
	G 3/4 H30
- Flanges	DN 15 H31
	DN 25 H32
• Drain hole	G 1/4 J18
	G 1/2 J19
• Free of oil and grease	J85
• Materials	
- NACE	H01

Option code applies only if not standard

J22

Options

5 Documentation

Please select requested documentation:

Inspections, tests:	Option code
DIN EN 10204-3.2: TÜV-Nord Certificate for test pressure	M33
LESER Certificate for Global Application	H03
- Inspection certificate 3.1 acc. to DIN EN 10204	
- Declaration of conformity acc. to PED 97/23/EC	
Material test certificate:	
DIN EN 10204-3.1	
Part	Option code
Body	H01
Bonnet	L30
Cap / lever cover	L31
Disc	L23
Studs	N07
Nuts	N08

H01 L30

Documentation

6 Code and Medium

1	2
2	0
1 Code	
1. ASME Section VIII	
2. CE / VdTUEV	
3. ASME Section VIII + CE / VdTUEV	
2 Medium	
.1 Gases	
.2 Liquids	
.3 Steam	
.0 Steam / Gases / Liquids (valid only for CE / VdTUEV)	

2.0

Code and Medium

Type 441, 442 ANSI

How to order – Article numbers

Type 441, 442 ANSI

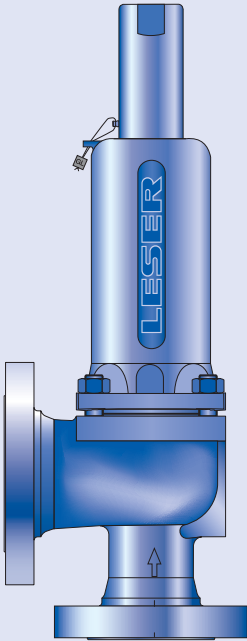

Type 441
Cap H2
Closed bonnet
Conventional design

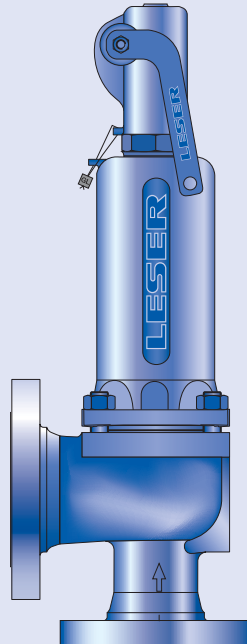

Type 441
Packed lever H4
Closed bonnet
Conventional design

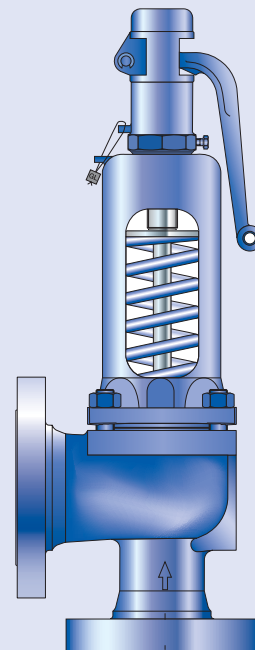

Type 442
Plain lever H3
Open bonnet
Conventional design

How to order – Article numbers

Article numbers			1" x 2"	1 1/2" x 2"	1 1/2" x 2 1/2"	2" x 3"	3" x 4"	4" x 6"
Valve size			1" x 2"	1 1/2" x 2"	1 1/2" x 2 1/2"	2" x 3"	3" x 4"	4" x 6"
Actual Orifice diameter d_0 [mm]			23	29	37	46	60	92
Actual Orifice area A_0 [mm ²]			416	661	1075	1662	2827	6648
Body material: 1.0619 (WCB)								
Bonnet closed	H2	Art.-No. 4412.	4812	4822	4832	4842	4862	4872
	H3	Art.-No. 4412.	4813	4823	4833	4843	4863	4873
	H4	Art.-No. 4412.	4814	4824	4834	4844	4864	4874
open	H3	Art.-No. 4422.	4815	4825	4835	4845	4865	4875
Body material: 1.4408 (CF8M)								
Bonnet closed	H2	Art.-No. 4414.	7912	–	7932	7942	7962	7972
	H4	Art.-No. 4414.	7914	–	7934	7944	7964	7974

Dimensions and weights

Metric Units

Valve size	1" x 2"	1 1/2" x 2"	1 1/2" x 2 1/2"	2" x 3"	3" x 4"	4" x 6"
Actual Orifice diameter d ₀ [mm]	23	29	37	46	60	92
Actual Orifice area A ₀ [mm ²]	416	661	1075	1662	2827	6648
Weight [lbs]	10	13	16	22	33	75
with bellows	11	14	17	24	37	83
Center to face [mm]						
Inlet a	105	124	124	136	156	181
Outlet b	114	121	121	124	165	229
Height (H4) [mm]						
Standard H max.	339	455	496	556	685	844
Bellows H max.	378	497	534	602	741	902
Support brackets [mm]						
A						280
B						160
(drilled only on request)						Ø 18
D						250
E						25

Body material: 1.0619 (WCB)

ANSI Flange Class¹⁾	Inlet	CL150 or CL300
	Outlet	CL150

Body material: 1.4408 (CF8M)

ANSI Flange Class¹⁾	Inlet	CL150 or CL300	-	CL150 or CL300
	Outlet	CL150	-	CL150

¹⁾ Standard flange rating. For other flange drillings and facings please refer to page 02/14.

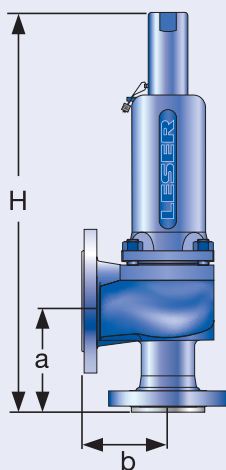

Conventional design

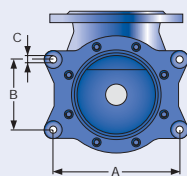
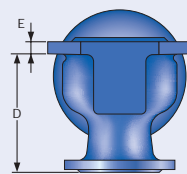

Support brackets

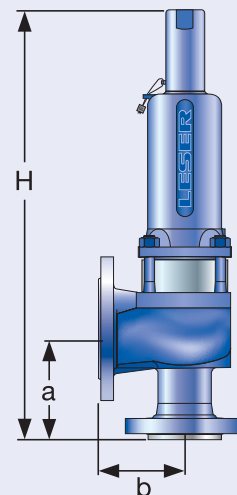

Balanced bellows design

Dimensions and weights

US Units		1" x 2"	1 1/2" x 2"	1 1/2" x 2 1/2"	2" x 3"	3" x 4"	4" x 6"
Valve size		1" x 2"	1 1/2" x 2"	1 1/2" x 2 1/2"	2" x 3"	3" x 4"	4" x 6"
Actual Orifice diameter d_0 [inch]		0,91	1,14	1,46	1,81	2,36	3,62
Actual Orifice area A_0 [inch ²]		0,644	1,024	1,667	2,576	4,383	10,304
Weight		22	29	35	49	73	165
[lbs]	with bellows	23	30	38	52	81	183
Center to face	Inlet a	4 1/8	4 7/8	4 7/8	5 3/8	6 1/8	7 1/8
[inch]	Outlet b	4 1/2	4 3/4	4 3/4	4 7/8	6 1/2	9
Height (H4)	Standard H max.	13 11/32	17 29/32	19 17/32	21 1/16	26 31/32	33 7/32
[inch]	Bellows H max.	14 7/8	19 9/16	21 1/32	23 11/16	29 3/16	35 1/2
Support brackets	A						11
[inch]	B						6 1/4
(drilled only on request)	C						Ø 3/4
	D						9 7/8
	E						25

Type 441, 442 ANSI

Body material: 1.0619 (WCB)					
ANSI Flange Class ¹⁾	Inlet			CL150 or CL300	
	Outlet			CL150	
Body material: 1.4408 (CF8M)					
ANSI Flange Class ¹⁾	Inlet	CL150 or CL300	-	CL150 or CL300	
	Outlet	CL150	-	CL150	

¹⁾ Standard flange rating. For other flange drillings and facings please refer to page 02/14.

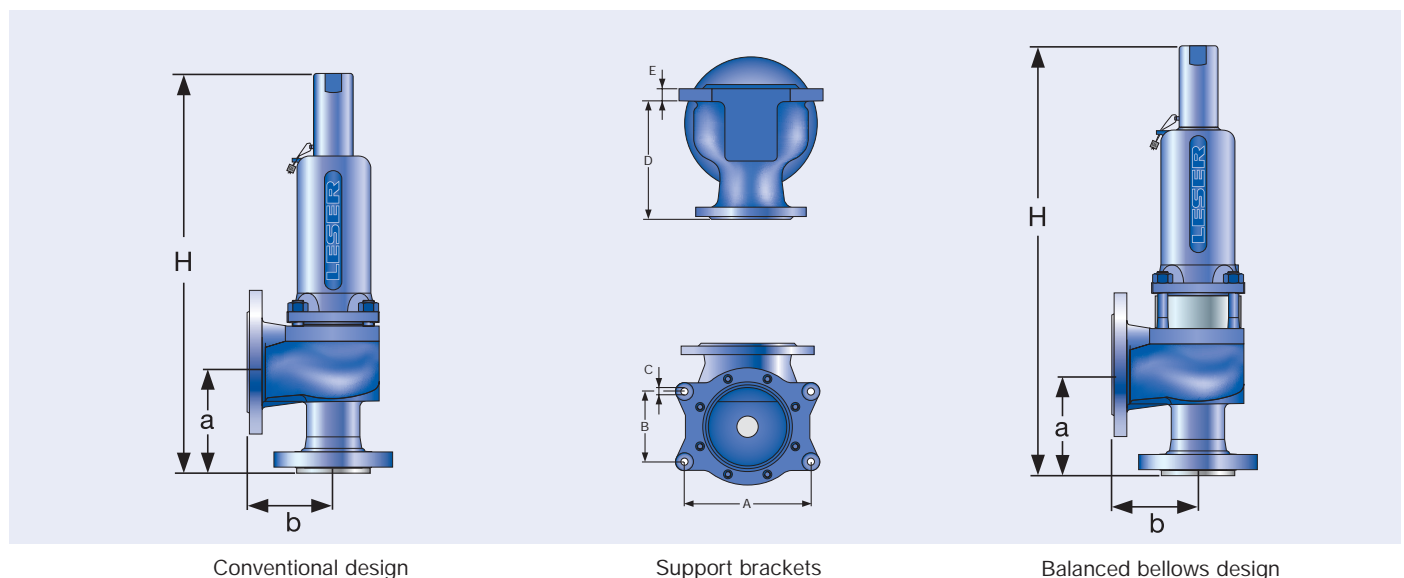

Pressure temperature ratings

Metric Units

Valve size	1" x 2"	1 1/2" x 2"	1 1/2" x 2 1/2"	2 x 3"	3 x 4"	4 x 6"
Actual Orifice diameter d ₀ [mm]	23	29	37	46	60	92
Actual Orifice area A ₀ [mm ²]	416	661	1075	1662	2827	6648

Body material: 1.0619 (WCB)

ANSI Flange Class ¹⁾	Inlet	CL150 or CL300					
	Outlet	CL150					
Minimum set pressure	p [bar _g] S/G/L	0,1	0,1	0,1	0,1	0,1	0,1
Min. set pressure ²⁾ standard bellows	p [bar _g] S/G/L	3	3	3	3	3	3
Min. set pressure low press. bellows	p [bar _g] S/G/L	0,98	1,41	1,11	1,81	1,50	1,18
Maximum set pressure	p [bar _g] S/G/L	49	48	46	51	35	34
Max. set pressure with special spring	p [bar _g] S/G/L	51	48	46	51	40	34
Temperature acc. to DIN EN	min. [°C]	-85					
	max. [°C]	+450					
Temperature acc. to ASME	min. [°C]	-29					
	max. [°C]	+427					

Body material: 1.4408 (CF8M)

ANSI Flange Class ¹⁾	Inlet	CL150 or CL 300	-	CL 150 or CL 300			
	Outlet	CL 150	-	CL 150			
Minimum set pressure	p [bar _g] S/G/L	0,1	-	0,1	0,1	0,1	0,1
Min. set pressure ²⁾ standard bellows	p [bar _g] S/G/L	3	-	3	3	3	3
Min. set pressure low press. bellows	p [bar _g] S/G/L	0,98	-	1,11	1,81	1,50	1,18
Maximum set pressure	p [bar _g] S/G/L	42,5	-	27	25	27	15
Max. set pressure with special spring	p [bar _g] S/G/L	51	-	38	40	27	25
Temperature acc. to DIN EN	min. [°C]	-270	-	-270			
	max. [°C]	+400	-	+400			
Temperature acc. to ASME	min. [°C]	-268	-	-268			
	max. [°C]	+538	-	+538			

¹⁾ For flange rating class 150 the pressure temperature ratings according to ASME ANSI B 16.34 apply.

²⁾ Min. set pressure standard bellows = Max. set pressure low pressure bellows.

Pressure temperature ratings

US Units							
Valve size		1" x 2"	1 1/2" x 2"	1 1/2" x 2 1/2"	2 x 3"	3 x 4"	4 x 6"
Actual Orifice diameter d ₀ [inch]		0,91	1,14	1,46	1,81	2,36	3,62
Actual Orifice area A ₀ [inch ²]		0,644	1,024	1,667	2,576	4,383	1,304
Body material: 1.0619 (WCB)							
ANSI Flange Class ¹⁾	Inlet	CL150 or CL300					
	Outlet	CL150					
Minimum set pressure	p [psig] S/G/L	1,5	1,5	1,5	1,5	1,5	1,5
Min. set pressure²⁾ standard bellows	p [psig] S/G/L	43,5	43,5	43,5	43,5	43,5	43,5
Min. set pressure low press. bellows	p [psig] S/G/L	14	20	16	26	22	17
Maximum set pressure	p [psig] S/G/L	711	696	667	740	508	493
Max. set pressure with special spring	p [psig] S/G/L	740	696	667	740	580	493
Temperature acc. to DIN EN	min. [°F]	-121					
	max. [°F]	+842					
Temperature acc. to ASME	min. [°F]	-20					
	max. [°F]	+800					

Body material: 1.4408 (CF8M)							
ANSI Flange Class ¹⁾	Inlet	CL 150 or CL 300	-	CL 150 or CL 300			
	Outlet	CL 150	-	CL 150			
Minimum set pressure	p [psig] S/G/L	1,5	-	1,5	1,5	1,5	1,5
Min. set pressure²⁾ standard bellows	p [psig] S/G/L	43,5	-	43,5	43,5	43,5	43,5
Min. set pressure low press. bellows	p [psig] S/G/L	14	-	16	26	22	17
Maximum set pressure	p [psig] S/G/L	616	-	392	363	392	218
Max. set pressure with special spring	p [psig] S/G/L	740	-	551	580	392	363
Temperature acc. to DIN EN	min. [°F]	-454	-	-454			
	max. [°F]	+752	-	+752			
Temperature acc. to ASME	min. [°F]	-450	-	-450			
	max. [°F]	+1000	-	+1000			

¹⁾ For flange rating class 150 the pressure temperature ratings according to ASME ANSI B 16.34 apply.

²⁾ Min. set pressure standard bellows = Max. set pressure low pressure bellows.

Flange drillings and facings

Flange drillings

Valve size		1" x 2"	1 1/2" x 2"	1 1/2" x 2 1/2"	2" x 3"	3" x 4"	4" x 6"
Actual Orifice diameter d ₀ [mm]		23	29	37	46	60	92
Actual Orifice area A ₀ [mm ²]		416	661	1075	1662	2827	6648
Body material: 0.6025 (cast iron)							
Inlet	ASME B16.5	CL150	H64	H64	H64	H64	H64
		CL300	*	*	*	*	*
Outlet	ASME B16.5	CL150	*	*	*	*	*
		CL300	-	-	-	-	-

Flange facings

Indication	Standard	Nozzle	Outlet	Remark						
General										
Flange undrilled	-	H38	H39							
Linde-V-Nut, Form V48	Linde Standard 420-08	J07	J08	Groove: Rz 16						
Linde-V-Nut, Form V48A	LWN 313.36	J05	J06	Groove: Rz 4, e.g. with hydrogen						
Lens seal form L (without sealing lens)	DIN 2696 LWN 313.35	J11	J12							
Acc. to DIN EN										
Flange facing				Remark						
DIN EN 1092 (new)		DIN 2526 (old)	Inlet	Outlet	Rz-data according to DIN EN 1092 in µm					
(see also LWN 313.40)			PN 10 – PN 40	PN 10 – PN 40						
Raised face	Type B1	Type C	*	*	Facing: Rz = 12,5 – 50					
	Type B2	Type D								
		Type E	L36	L38	Facing: Rz = 3,2 – 12,5					
Tongue face C ¹⁾		Tongue face F	H94	H92	Steel flanges only					
Groove face D ¹⁾		Groove face N	H93	H91						
Male face E		Male face V13	H96	H98						
Female face F		Female face R13	H96	H99						
O-ring male face G		Male face V14	J01	J02						
O-ring female face H		Female face R14	J03	J04						
Acc. to ASME B16.5										
Body material	Inlet	Outlet	Smooth finish ²⁾			Serrated finish		RTJ-groove		
			Inlet	Outlet	Inlet	Outlet	Inlet		Outlet	
			Option code	Option code	RTJ-Class	Option code	RTJ-Class	Option code		
1.0619, 1.4408	all	all	L51	L53	*	*	CL150	H62	CL150	H63

¹⁾ According to DIN EN 1092 groove depths and tongue heights increased compared to the formerly valid DIN (refer to LWN 313.40). LESER manufactures the groove at flanged valves by milling. If a customer demands a turned surface in the soil of the groove according to DIN 2512 and/or DIN EN 1092-1 an additional option code is necessary: "S01: bottom of the groove drilled". Groove and tongue for PN160 flanges refer to DIN 2512/LWN 313.32.

²⁾ Smooth finish is not defined in the effective standards. For LESER's definition for smooth finish see page 00/07.

For signs and symbols refer to page 00/07

Note: Flange drillings and facings meet always the requirements of mentioned flange standards. Flange thickness and outer diameter may vary from flange standard.

Order information – Spare parts

Spare parts		Valve size	1" x 2"	1½" x 2"	1½" x 2½"	2" x 3"	3" x 4"	4" x 6"
Actual Orifice diameter d ₀ [mm]			23	29	37	46	60	92
Actual Orifice area A ₀ [mm ²]			416	661	1075	1662	2827	6648
Disc (Item 7): Metal to metal seat		Material-No. / Art.-No.						
Disc detachable lifting aid	1.4122	210.9739.9000	210.9839.9000	210.9939.9000	210.8739.9000	220.1639.9000	220.1839.9000	
	1.4404	210.9749.9000	210.9849.9000	210.9949.9000	210.8749.9000	220.1649.9000	220.1849.9000	
Disc (Item 7): Soft seal		Material-No. / Art.-No.						
Disc	CR "K"	200.5049.9051	200.5149.9051	200.5249.9051	200.5349.9051	200.5449.9051	on request	
	EPDM "D"	200.5049.9041	200.5149.9041	200.5249.9041	200.5349.9041	200.5449.9041	200.5649.9041	
	FPM "L"	200.5049.9071	200.5149.9071	200.5249.9071	200.5349.9071	200.5449.9071	200.5649.9071	
	FFKM "C"	200.5049.9091	200.5149.9091	200.5249.9091	200.5349.9091	on request	on request	
O-ring (Item 7.4): Soft seal		Material-No. / Art.-No.						
O-ring	CR "K"	502.0249.3551	502.0313.3551	502.0408.3551	502.0503.3551	502.0660.5351	on request	
	EPDM "D"	502.0249.3541	502.0313.3541	502.0408.3541	502.0503.3541	502.0660.5341	502.1041.5341	
	FKM "L"	502.0249.3571	502.0313.3571	502.0408.3571	502.0503.3571	502.0660.5371	502.1041.5371	
	FFKM "C"	502.0249.3591	502.0313.3591	502.0408.3591	502.0503.3591	on request	on request	
Bellows (Item 15): 1.4571		Material-No. / Art.-No.						
Standard bellows		400.0949.0000	400.1049.0000	400.1149.0000	400.1249.0000	400.1349.0000	400.0849.0000	
Conversion kit standard¹⁾		5021.1041	5021.1042	5021.1043	5021.1044	5021.1045	5021.1047	
Low pressure bellows		400.0949.0021	400.1049.0021	400.1149.0021	400.1249.0021	400.1349.0021	400.0849.0021	
Conversion kit low pressure¹⁾		please specify in writing						
Gasket – Body / bonnet (Item 60)		Material-No. / Art.-No.						
Gasket	Graphite + 1.4401	500.0607.0000	500.0807.0000	500.1007.0000	500.1207.0000	500.1607.0000	500.2107.0000	
	Option code L68 Gylon (filled PTFE)	500.0605.0000	500.0805.0000	500.1005.0000	500.1205.0000	500.1605.0000	500.2105.0000	
Ball (Item 61)		Material-No. / Art.-No.						
Ball	Ball Ø [mm]	6	6	9	9	12	15	
	1.4404	510.0104.0000	510.0104.0000	510.0204.0000	510.0204.0000	510.0304.0000	510.0404.0000	
Split ring (Item 14)		Material-No. / Art.-No.						
Split ring	Spindle Ø [mm]	12	16	16	16	20	24	
	1.4404	251.0149.0000	251.0249.0000	251.0249.0000	251.0249.0000	251.0349.0000	251.0449.0000	
Pin (Item 57)		Material-No. / Art.-No.						
Pin	1.4310	480.0505.0000	480.0705.0000	480.0705.0000	480.0705.0000	480.1005.0000	480.1105.0000	

¹⁾ For pressure range see page 02/12 – 02/13.
A conversion kit contains the following components:

Item	Component	No.
8	Guide	1
11	Bonnet spacer	1
12	Spindle	1
15	Bellows	1
55	Stud	4, 8 depends on valve size
60	Gasket	2, 3 depends on valve size
	Installation instruction LWN 037.05	1

Refer to page 02/04

Type 441, 442 ANSI

Available Options

For further information refer to "Accessories and Options", page 99/01

Type 441, 442 ANSI

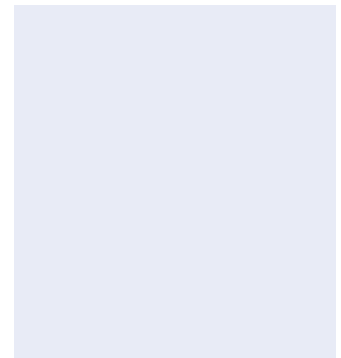
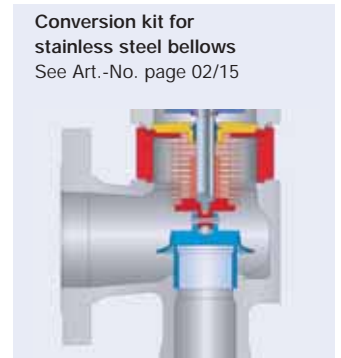
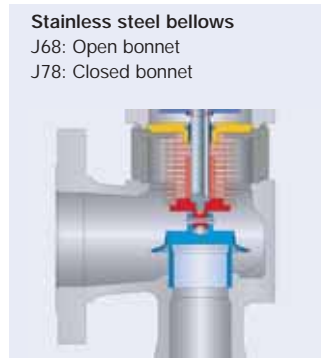
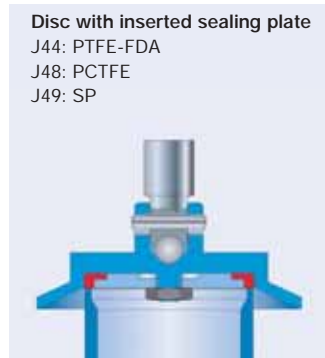
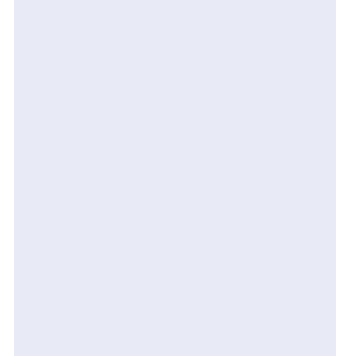
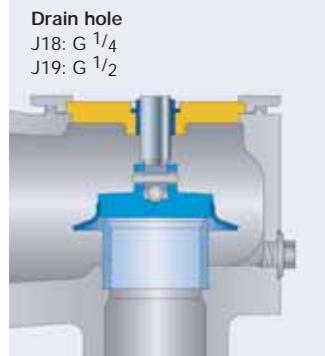

Approvals

Approvals		
	Valve size	1" x 2" up to 4" x 6"
	Actual Orifice diameter d_0 [mm]	23 – 92
	Actual Orifice area A_0 [mm ²]	416 – 6648
Europe		Coefficient of discharge K_{dr}
DIN EN ISO 4126-1	Approval No.	072020111Z0008/0/08-2
	S/G	0,7
	L	0,45
Germany		Coefficient of discharge α_w
AD 2000-Merkblatt A2	Approval No.	TÜV SV 576
	S/G	0,7
	L	0,45
United States		Coefficient of discharge K
ASME Sec. VIII	Approval No.	M37044
	S/G	0,699
	Approval No.	M37055
	L	0,521
Canada		Coefficient of discharge K
Canada: CRN	Approval No.	OG1182.9C
	S/G	0,699
	L	0,521
China		Coefficient of discharge α_w
CSBQTS	Approval No.	
	S/G	0,7
	L	0,45
Russia		Coefficient of discharge α_w
GGTN/ GOSGOTECHNADZOR GOST R	Approval No.	PPC 00-18458
	S/G	0,7
	L	0,45
Classification societies		Homepage
Bureau Veritas	BV	www.bureauveritas.com
Det Norske Veritas	DNV	www.dnv.com
Germanischer Lloyd	GL	www.gl-group.com
Lloyd' s register EMEA	LREMEA	www.lr.org
Registro Italiano Navale	RINA	www.rina.org
<p>The valid certification number is changed with every renewal.</p> <p>A sample certificate including the valid certification number can be taken from the homepage of the classification societies.</p>		

Capacities – Steam

Capacities for saturated steam according to AD 2000-Merkblatt A2, based on set pressure plus 10 % overpressure.
Capacities at 1 bar (14,5 psig) and below are based on 0,1 bar (1,45 psig) overpressure.

Metric Units	AD 2000-Merkblatt A2 [kg/h]					
Valve size	1"x 2"	1½" x 2"	1½" x 2½"	2" x 3"	3" x 4"	4" x 6"
Act. Orifice dia. d ₀ [mm]	23	29	37	46	60	92
Act. Orifice area A ₀ [mm ²]	416	661	1075	1662	2827	6648
LEO _{S/G} ^{*)} [inch ²]	0,462	0,734	1,195	1,847	3,142	7,387
Set pressure [bar]	Capacities [kg/h]					
0,1	0	0	0	0	0	0
0,2	140	223	363	561	954	2243
0,5	224	356	579	895	1523	3580
1	326	518	843	1302	2215	5209
2	519	825	1343	2075	3531	8302
3	699	1111	1808	2794	4754	11178
4	871	1385	2254	3485	5928	13938
5	1043	1658	2699	4172	7097	16687
6	1214	1930	3142	4856	8262	19426
7	1381	2196	3574	5525	9399	22098
8	1551	2466	4014	6205	10556	24818
9	1721	2736	4454	6884	11712	27535
10	1891	3006	4893	7562	12866	30250
12	2230	3545	5770	8919	15174	35675
14	2562	4073	6629	10247	17433	40987
16	2900	4610	7505	11600	19735	46400
18	3239	5149	8382	12955	22041	51820
20	3578	5688	9260	14312	24350	57249
22	3907	6212	10111	15629	26590	62515
24	4247	6752	10991	16988	28903	67953
26	4588	7294	11873	18351	31222	73405
28	4930	7837	12757	19718	33547	78873
30	5272	8382	13644	21089	35880	84358
32	5616	8929	14534	22465	38220	89860
34	5945	9451	15384	23779	40455	95115
36	6290	10000	16278	25160	42806	
38	6637	10551	17175	26547	45165	
40	6985	11104	18076	27939	47533	
42	7334	11660	18980	29337		
44	7685	12218	19888	30740		
46	8037	12778	20800	32150		
48	8391	13341		33566		
50	8747			34988		
51	8900			35600		

Capacities for saturated steam according to ASME Section VIII (UV), based on set pressure plus 10% overpressure.
Capacities at 2,07 bar (30 psig) and below are based on 0,207 bar (3 psig) overpressure.

US Units	ASME Section VIII [lb/h]					
Valve size	1"x 2"	1½" x 2"	1½" x 2½"	2" x 3"	3" x 4"	4" x 6"
Act. Orifice dia. d ₀ [inch]	0,91	1,14	1,46	1,81	2,36	3,62
Act. Orifice area A ₀ [inch ²]	0,644	1,024	1,667	2,576	4,383	10,304
LEO _{S/G} ^{*)} [inch ²]	0,462	0,734	1,195	1,847	3,142	7,387
Set pressure [psig]	Capacities [lb/h]					
15	757	1204	1959	3028	5152	12113
20	873	1388	2259	3492	5941	13968
30	1105	1756	2859	4419	7519	17677
40	1360	2162	3519	5439	9254	21757
50	1615	2567	4179	6459	10989	25837
60	1870	2973	4839	7479	12725	29917
70	2125	3378	5499	8499	14460	33997
80	2380	3783	6159	9519	16196	38078
90	2635	4189	6819	10539	17931	42158
100	2890	4594	7479	11559	19666	46238
120	3400	5405	8799	13600	23137	54398
140	3910	6216	10118	15640	26608	62558
160	4420	7027	11438	17680	30079	70719
180	4930	7838	12758	19720	33550	78879
200	5440	8648	14078	21760	37020	87039
220	5950	9459	15398	23800	40491	95200
240	6460	10270	16718	25840	43962	103360
260	6970	11081	18038	27880	47433	111520
280	7480	11892	19358	29920	50904	119680
300	7990	12703	20677	31960	54375	127841
320	8500	13513	21997	34000	57845	136001
340	9010	14324	23317	36040	61316	144161
360	9520	15135	24637	38080	64787	152321
380	10030	15946	25957	40120	68258	160482
400	10540	16757	27277	42161	71729	168642
420	11050	17567	28597	44201	75199	176802
440	11560	18378	29917	46241	78670	184963
460	12070	19189	31236	48281	82141	193123
480	12580	20000	32556	50321	85612	201283
500	13090	20811	33876	52361	89083	209443
550	14365	22838	37176	57461	97760	
600	15640	24865	40476	62561		
650	16915	26892	43775	67661		
700	18190	28919		72762		
740	19210			76842		

^{*)} LEO_{S/G} = LESER Effective Orifice steam/gas please refer to page 00/11
How to use capacity-sheets refer to page 00/09

Capacities – Air

Capacities for air according to AD 2000-Merkblatt A2, based on set pressure plus 10 % overpressure at 0 °C and 1013 mbar. Capacities at 1 bar (14,5 psig) and below are based on 0,1 bar (1,45 psig) overpressure.

Metric Units		AD 2000-Merkblatt A2 [m _n ³ /h]					
Valve size	1"x 2"	1½" x 2"	1½" x 2½"	2" x 3"	3" x 4"	4" x 6"	
Act. Orifice dia. d ₀ [mm]	23	29	37	46	60	92	
Act. Orifice area A ₀ [mm ²]	416	661	1075	1662	2827	6648	
LEO _{S/G} ^{*)} [inch ²]	0,462	0,734	1,195	1,847	3,142	7,387	
Set pressure [bar]	Capacities [m _n ³ /h]						
0,1	0	0	0	0	0	0	
0,2	162	258	420	649	1105	2597	
0,5	263	418	680	1051	1789	4206	
1	388	617	1004	1552	2641	6209	
2	627	996	1622	2507	4265	10026	
3	854	1357	2209	3414	5809	13657	
4	1071	1703	2773	4286	7291	17143	
5	1289	2050	3337	5157	8774	20629	
6	1507	2396	3900	6029	10257	24114	
7	1725	2742	4464	6900	11739	27600	
8	1943	3089	5028	7771	13222	31086	
9	2161	3435	5592	8643	14704	34571	
10	2379	3781	6155	9514	16187	38057	
12	2814	4474	7283	11257	19152	45028	
14	3250	5167	8411	13000	22117	52000	
16	3686	5859	9538	14743	25082	58971	
18	4121	6552	10666	16486	28047	65942	
20	4557	7245	11793	18228	31012	72913	
22	4993	7938	12921	19971	33977	79885	
24	5429	8630	14048	21714	36943	86856	
26	5864	9323	15176	23457	39908	93827	
28	6300	10016	16304	25200	42873	100799	
30	6736	10708	17431	26942	45838	107770	
32	7171	11401	18559	28685	48803	114741	
34	7607	12094	19686	30428	51768	121713	
36	8043	12786	20814	32171	54733		
38	8478	13479	21941	33914	57698		
40	8914	14172	23069	35657	60663		
42	9350	14864	24197	37399			
44	9786	15557	25324	39142			
46	10221	16250	26452	40885			
48	10657	16942		42628			
50	11093			44371			
51	11311			45242			

^{*)} LEO_{S/G} = LESER Effective Orifice steam/gas please refer to page 00/11
How to use capacity-sheets refer to page 00/09

Capacities for air according to ASME Section VIII (UV), based on set pressure plus 10 % overpressure at 16 °C (60 °F). Capacities at 2,07 bar (30 psig) and below are based on 0,207 bar (3 psig) overpressure.

US Units		ASME Section VIII [S.C.F.M.]					
Valve size	1"x 2"	1½" x 2"	1½" x 2½"	2" x 3"	3" x 4"	4" x 6"	
Act. Orifice dia. d ₀ [inch]	0,91	1,14	1,46	1,81	2,36	3,62	
Act. Orifice area A ₀ [inch ²]	0,644	1,024	1,667	2,576	4,383	10,304	
LEO _{S/G} ^{*)} [inch ²]	0,462	0,734	1,195	1,847	3,142	7,387	
Set pressure [psig]	Capacities [S.C.F.M.]						
15	270	429	698	1079	1835	4315	
20	311	494	805	1244	2116	4976	
30	394	626	1019	1574	2679	6297	
40	484	770	1254	1938	3297	7750	
50	575	915	1489	2301	3915	9204	
60	666	1059	1724	2664	4533	10657	
70	757	1204	1959	3028	5152	12111	
80	848	1348	2194	3391	5770	13564	
90	939	1492	2430	3754	6388	15018	
100	1029	1637	2665	4118	7006	16471	
120	1211	1926	3135	4845	8243	19378	
140	1393	2215	3605	5571	9479	22285	
160	1574	2504	4076	6298	10716	25192	
180	1756	2792	4546	7025	11952	28099	
200	1938	3081	5016	7751	13189	31006	
220	2120	3370	5486	8478	14425	33913	
240	2301	3659	5957	9205	15662	36820	
260	2483	3948	6427	9932	16898	39727	
280	2665	4237	6897	10658	18135	42633	
300	2846	4526	7368	11385	19371	45540	
320	3028	4815	7838	12112	20608	48447	
340	3210	5104	8308	12839	21844	51354	
360	3391	5392	8778	13565	23081	54261	
380	3573	5681	9249	14292	24317	57168	
400	3755	5970	9719	15019	25554	60075	
420	3936	6259	10189	15745	26791	62982	
440	4118	6548	10660	16472	28027	65889	
460	4300	6837	11130	17199	29264	68796	
480	4481	7126	11600	17926	30500	71703	
500	4663	7415	12070	18652	31737	74610	
550	5117	8137	13246	20469	34828		
600	5572	8859	14422	22286			
650	6026	9581	15598	24103			
700	6480	10303		25920			
740	6843			27373			

Capacities – Water

Capacities for water according to AD 2000-Merkblatt A2, based on set pressure plus 10 % overpressure at 20 °C (68 °F). Capacities at 1 bar (14,5 psig) and below are based on 0,1 bar (1,45 psig) overpressure.

Capacities for water according to ASME Section VIII (UV), based on set pressure plus 10 % overpressure at 21 °C (70 °F). Capacities at 2,07 bar (30 psig) and below are based on 0,207 bar (3 psig) overpressure.

Metric Units	AD 2000-Merkblatt A2 [10 ³ kg/h]					
Valve size	1"x 2"	1½" x 2"	1½" x 2½"	2" x 3"	3" x 4"	4" x 6"
Act. Orifice dia. d ₀ [mm]	23	29	37	46	60	92
Act. Orifice area A ₀ [mm ²]	416	661	1075	1662	2827	6648
LEO _L ^{*)} [inch ²]	0,516	0,821	1,336	2,065	3,513	8,259
Set pressure [bar]	Capacities [10 ³ kg/h]					
0,1	4,25	6,76	11,0	17,0	28,9	68,0
0,2	5,21	8,28	13,5	20,8	35,4	83,3
0,5	7,37	11,7	19,1	29,5	50,1	118
1	10,0	15,9	25,8	39,9	67,9	160
2	14,1	22,4	36,5	56,4	96,0	226
3	17,3	27,5	44,7	69,1	118	276
4	19,9	31,7	51,6	79,8	136	319
5	22,3	35,5	57,7	89,2	152	357
6	24,4	38,8	63,2	97,7	166	391
7	26,4	42,0	68,3	106	180	422
8	28,2	44,8	73,0	113	192	451
9	29,9	47,6	77,4	120	204	479
10	31,5	50,1	81,6	126	215	505
12	34,6	54,9	89,4	138	235	553
14	37,3	59,3	96,6	149	254	597
16	39,9	63,4	103	160	271	638
18	42,3	67,3	110	169	288	677
20	44,6	70,9	115	178	304	714
22	46,8	74,4	121	187	318	748
24	48,9	77,7	126	195	333	782
26	50,9	80,9	132	203	346	814
28	52,8	83,9	137	211	359	844
30	54,6	86,8	141	219	372	874
32	56,4	89,7	146	226	384	903
34	58,2	92,5	151	233	396	931
36	59,8	95,1	155	239	407	
38	61,5	97,7	159	246	418	
40	63,1	100	163	252	429	
42	64,6	103	167	259		
44	66,2	105	171	265		
46	67,6	108	175	271		
48	69,1	110		276		
50	70,5			282		
51	71,2			285		

US Units	ASME Section VIII [US-G.P.M.]					
Valve size	1"x 2"	1½" x 2"	1½" x 2½"	2" x 3"	3" x 4"	4" x 6"
Act. Orifice dia. d ₀ [inch]	0,91	1,14	1,46	1,81	2,36	3,62
Act. Orifice area A ₀ [inch ²]	0,644	1,024	1,667	2,576	4,383	10,304
LEO _L ^{*)} [inch ²]	0,516	0,821	1,336	2,065	3,513	8,259
Set pressure [psig]	Capacities [US-G.P.M.]					
15	54,0	85,9	140	216	368	864
20	61,1	97,1	158	244	416	977
30	73,1	116	189	293	498	1170
40	84,5	134	219	338	575	1351
50	94,4	150	244	378	643	1511
60	103	164	268	414	704	1655
70	112	178	289	447	760	1787
80	119	190	309	478	813	1911
90	127	201	328	507	862	2027
100	134	212	346	534	909	2136
120	146	233	379	585	996	2340
140	158	251	409	632	1075	2528
160	169	269	437	676	1150	2702
180	179	285	464	717	1219	2866
200	189	300	489	755	1285	3021
220	198	315	513	792	1348	3169
240	207	329	535	827	1408	3310
260	215	342	557	861	1465	3445
280	223	355	578	894	1521	3575
300	231	368	599	925	1574	3700
320	239	380	618	955	1626	3822
340	246	391	637	985	1676	3939
360	253	403	656	1013	1724	4054
380	260	414	674	1041	1772	4165
400	267	425	691	1068	1818	4273
420	274	435	708	1095	1862	4378
440	280	445	725	1120	1906	4481
460	286	455	741	1146	1949	4582
480	293	465	757	1170	1991	4681
500	299	475	773	1194	2032	4777
550	313	498	811	1253	2131	
600	327	520	847	1308		
650	340	541	881	1362		
700	353	562		1413		
740	363			1453		

^{*)} LEO_L = LESER Effective Orifice liquids please refer to page 00/12
How to use capacity-sheets please refer to page 00/09

Determination of coefficient of discharge in case of lift restriction or back pressure

- h = Lift [mm]
- d_0 = Flow diameter [mm] of selected safety valve, refer to table article numbers
- h/d_0 = Ratio of lift / flow diameter
- p_{a0} = Back pressure [bar_a]
- p_0 = Set pressure [bar_a]
- p_{a0}/p_0 = Ratio of back pressure / set pressure
- K_{dr} = Coefficient of discharge acc. to DIN EN ISO 4126-1
- α_w = Coefficient of discharge acc. to AD 2000-Merkblatt A2
- K_b = Back pressure correction factor acc. to API 520 topic 3.3

Diagram for evaluation of ratio of lift / flow diameter (h/d_0) in reference to the coefficient of discharge (K_{dr}/α_w)

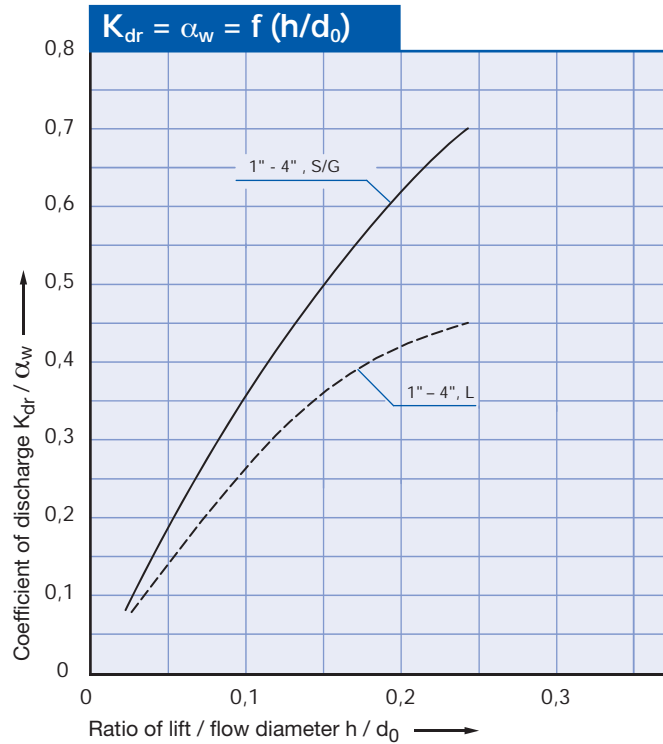
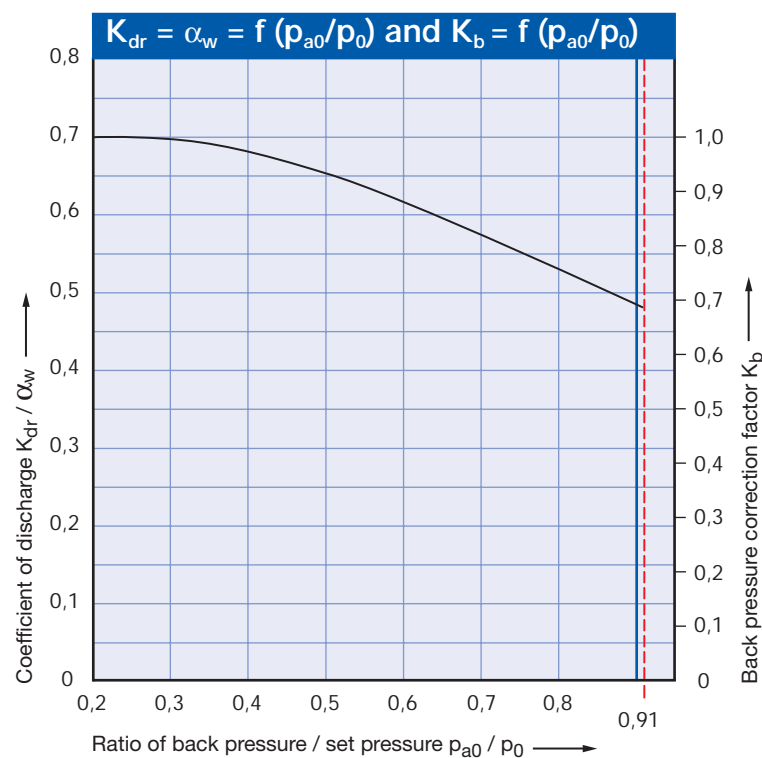

Diagram for evaluation of coefficient of discharge (K_{dr}/α_w) or K_b in reference to the ratio of back pressure / set pressure (p_{a0}/p_0)



How to use please refer to page 00/08

Type 441 XXL 442 XXL

Flanged Safety Relief Valves – spring loaded



Type 441 XXL
Packed lever
Closed bonnet
Conventional and
balanced bellows design

Contents	Chapter/Page
Materials	
• Conventional design	03/02
• Balanced bellows design	03/04
How to order	
• Numbering system	03/06
• Article numbers	03/08
Dimensions and weights	
• Metric Units	03/10
• US Units	03/11
Pressure temperature ratings	
• Metric Units	03/12
• US Units	03/13
Flange drillings and facings	03/14
Order information – Spare parts	03/15
Available options	03/16
Approvals	03/17
Capacities	
• Steam [Metric Units + US Units]	03/18
• Air [Metric Units + US Units]	03/19
• Water [Metric Units + US Units]	03/20
Determination of coefficient of discharge K_{dr}/α_w	03/21

Type 441, 442 XXL

Conventional design

Type 441, 442 XXL

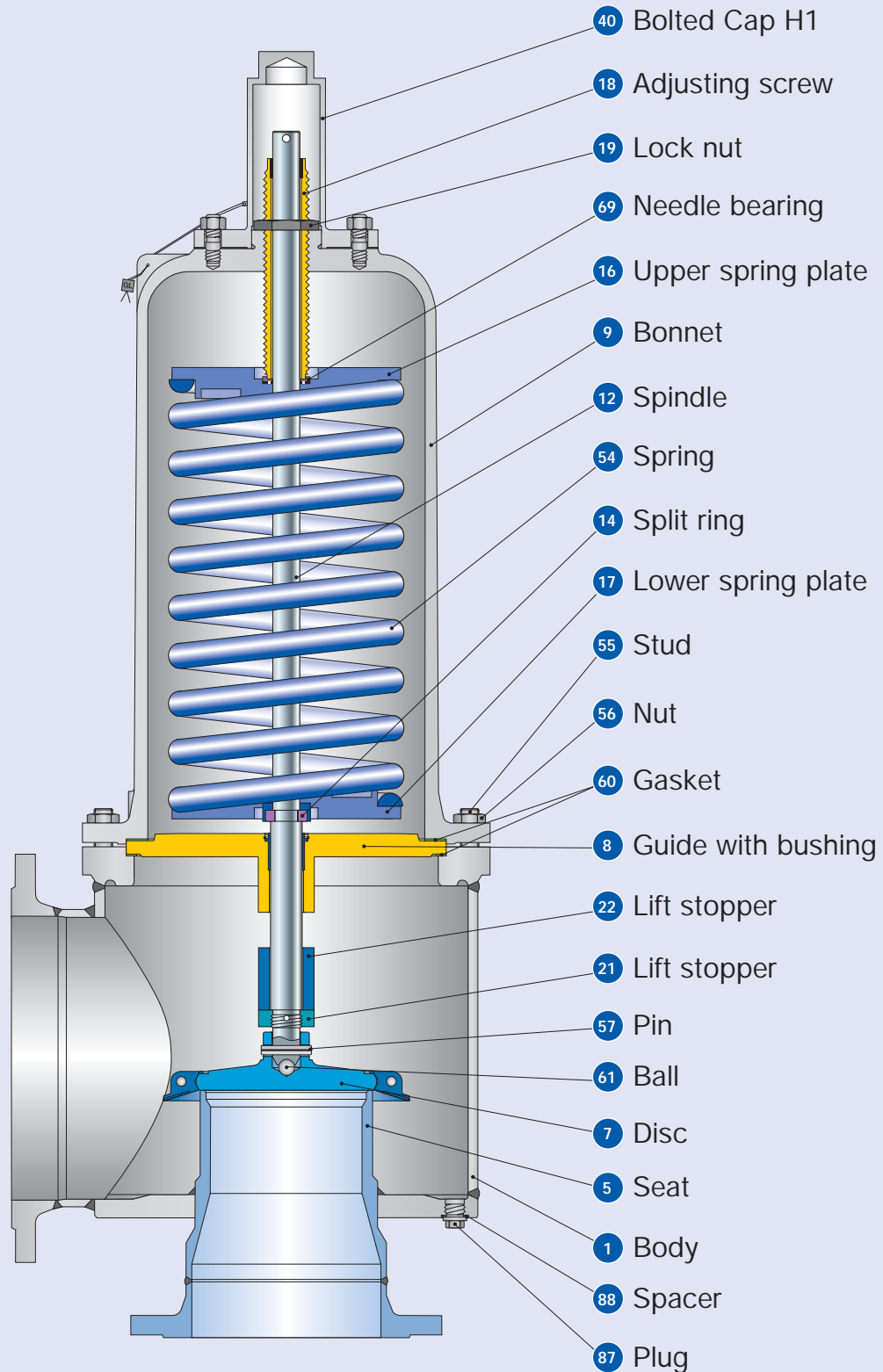

Conventional design

Materials			
Item	Component	Type 4412 XXL / 4422 XXL	Type 4414 XXL
1	Body	1.4060/1.0425	1.4571
		Carbon steel	316Ti
5	Seat	1.0305 stellite, 1.0460 stellite	1.4571
		Carbon steel, stellite	316Ti
7	Disc	1.4404	1.4571
		316L	316Ti
8	DN 200 – 250: Guide with bushing	0.7040	1.4404
		Ductile Gr. 60-40-18 / Chrome steel	316L
	DN 300 – 400: Guide	1.4404	1.4404
		316L	316L
9	Bonnet	0.7043 or 1.0254	1.4571
		Ductile Gr. 60-40-18 or Steel	316Ti
12	Spindle	1.4021	1.4404
		420	316L
14	Split ring	1.4104	1.4404
		Chrome steel	316L
16 / 17	Spring plate	1.0570 or 1.4404	1.4404
		Steel or 316L	316L
18	Adjusting screw with bushing	1.4104 PTFE	1.4404 PTFE
		Chrome steel PTFE	316L PTFE
19	Lock nut	1.4404	1.4404
		316L	316L
21 / 22	Lift stopper	1.4404	1.4404
		316L	316L
40	Bolted cap H1	0.7040	1.4404
		Ductile Gr. 60-40-18	316L
54	Spring standard	1.1200, 1.8159, 1.7102	1.4310
		Carbon steel	Stainless steel
	Spring optional	1.4310	-
		Stainless steel	-
55	Stud	1.1181	1.4401
		Steel	B8M
56	Nut	1.0501	1.4401
		2H	8M
57	Pin	1.4310	1.4310
		Stainless steel	Stainless steel
60	Gasket	Graphite / 1.4401	Graphite / 1.4401
		Graphite / 316	Graphite / 316
61	Ball	1.3541	1.4401
		Hardened stainless steel	316
69	Needle bearing	1.4401	1.4401
		316L	316L
87 / 88	Plug / Spacer	1.4401 / 1.4571	1.4401 / 1.4571
		316 / 316Ti	316 / 316Ti

Please notice:

- Modifications reserved by LESER.
- LESER can upgrade materials without notice.
- Every part can be replaced by other material acc. to customer specification.

Type 441, 442 XXL

LESER

Balanced bellows design

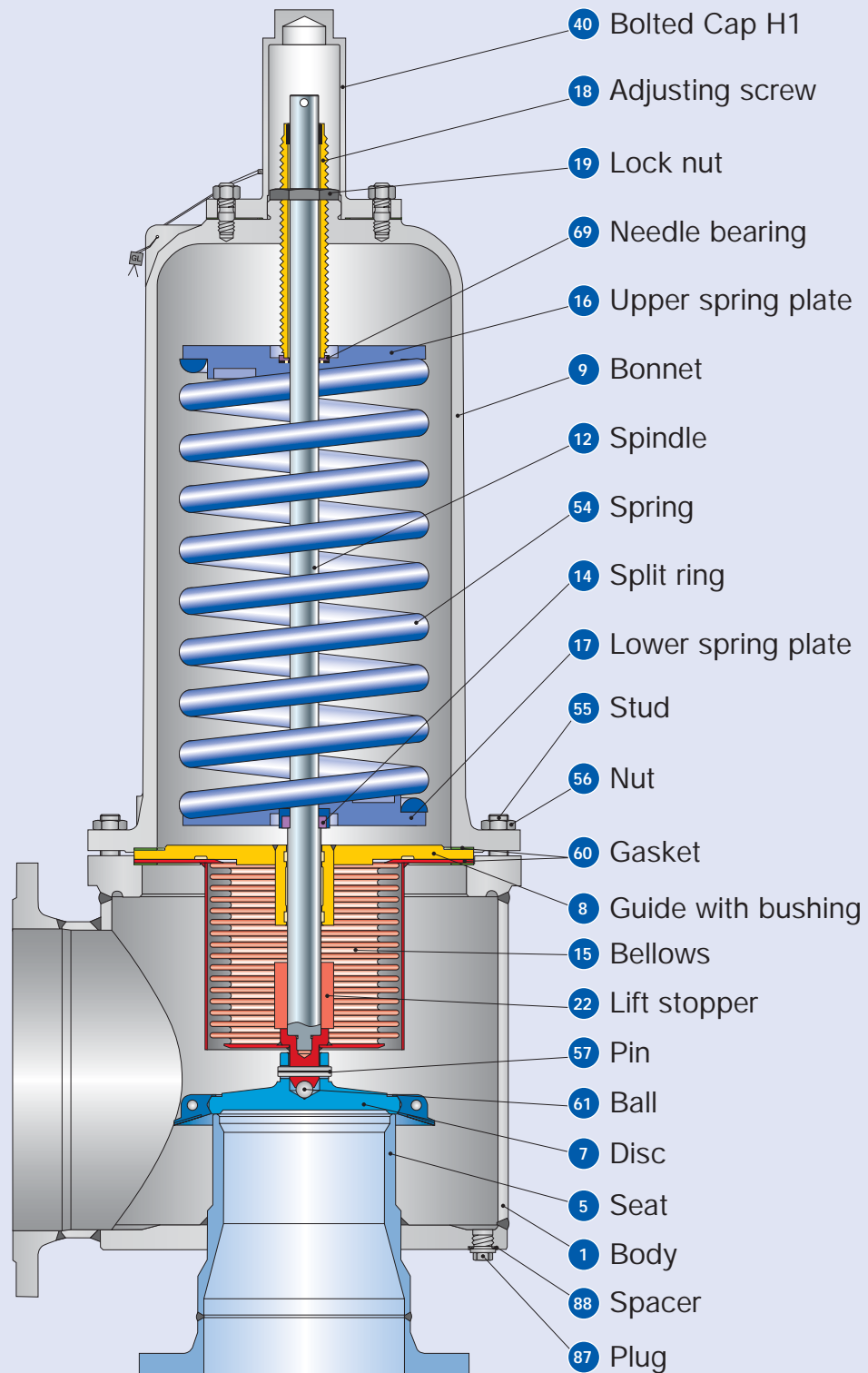

Type 441, 442 XXL

Balanced bellows design

Materials			
Item	Component	Type 4412 XXL / 4422 XXL	Type 4414 XXL
1	Body	1.4060/1.0425	1.4571
		Carbon steel	316Ti
5	Seat DN 200 – 250	1.0305 stellited	1.4571
	DN 300 – 400	Carbon steel, stellited	316Ti
		1.0460 stellited	1.4571
7	Disc	Carbon steel, stellited	316Ti
		1.4404	1.4571
8	Guide	316L	316Ti
		1.4571	1.4571
9	Bonnet	316Ti	316Ti
		0.7043 or 1.0254	1.4571
12	Spindle	Ductile Gr. 60-40-18 or Steel	316Ti
		1.4404	1.4404
14	Split ring	316L	316L
		1.4104	1.4404
15	Bellows	Chrome steel	316L
		1.4571	1.4571
16 / 17	Spring plate	316Ti	316Ti
		1.0570 or 1.4404	1.4404
18	Adjusting screw with bushing	Steel or 316L	316L
		1.4104 PTFE	1.4404 PTFE
19	Lock nut	Chrome steel PTFE	316L PTFE
		1.4404	1.4404
22	Lift stopper	316L	316L
		1.4404	1.4404
40	Bolted cap H1	1.4404	1.4404
		0.7040	1.4404
54	Spring standard	Ductile Gr. 60-40-18	316L
		1.1200, 1.8159, 1.7102	1.4310
	Spring optional	Carbon steel	Stainless steel
55	Stud	1.4310	-
		Stainless steel	-
56	Nut	1.1181	1.4401
		Steel	B8M
57	Pin	1.0501	1.4401
		2H	8M
60	Gasket	1.4310	1.4310
		Stainless steel	Stainless steel
61	Ball	Graphite / 1.4401	Graphite / 1.4401
		Graphite / 316	Graphite / 316
69	Needle bearing	1.3541	1.4401
		Hardened stainless steel	316
87 / 88	Plug / Spacer	1.4401	1.4401
		316L	316L
87 / 88	Plug / Spacer	1.4401 / 1.4571	1.4401 / 1.4571
		316 / 316Ti	316 / 316Ti

Please notice:

- Modifications reserved by LESER.
- LESER can upgrade materials without notice.
- Every part can be replaced by other material acc. to customer specification.

How to order – Numbering system

1

Article Number

1	2	3	4
441	2	475	2

1 Valve Type 441, 442 XXL
 Type 441 – with closed bonnet
 Type 442 – with open bonnet

2 Material code

Code	Body material
2	1.0460/1.0425 (Carbon steel)
4	1.4571 (316Ti)

3 Valve code
 Identifies valve size and body material, refer to page 03/09.

4

Code	Lifting lever	
2	bolted cap	H1
4	bolted lifting device	H6
5	bolted lifting device	H3

4412.4752

Article No.

2

Set Pressure

Please state unit (in gauge)!

Please do not exceed the pressure range defined in the spring charts.

5 barg

Set Pressure

3

Connections

Please refer to page 03/14

H45

Connections

4 Options

Type 441, 442 XXL	Option code
• O-ring-disc	
CR	"K" J21
EPDM	"D" J22
FKM	"L" J23
FFKM	"C" J20
• Disc 1.4404 / 316L stellited	J25
• Seat stellited	L61
• Stainless steel bel lows	
- open bonnet (Type 442)	J68
- closed bonnet (Type 441)	J78
• High temperature alloy spring	X01
• Stainless steel spring	X04
• Adaptor for lift indicator	H6 J39
• Lift indicator	J93
• Test gag	
- bolted cap	H1 J70
- bolted lifting device	H6 J69
• Seat 1.4404 / 316L stellited	L61
• Drain hole	G 1/2 J19
• Free of oil and grease	J85
• Materials	
- NACE	H01

Option code applies only if not standard

J22

Options

5 Documentation

Please select requested documentation:

Inspections, tests:	Option code
DIN EN 10204-3.2: TÜV-Nord Certificate for test pressure	M33
LESER Certificate for Global Application	H03
- Inspection certificate 3.1 acc. to DIN EN 10204	
- Declaration of conformity acc. to PED 97/23/EC	
Material test certificate:	
DIN EN 10204-3.1	
Part	Option code
Body	H01
Bonnet	L30
Cap / lever cover	L31
Disc	L23
Studs	N07
Nuts	N08

H01 L30

Documentation

6 Code and Medium

1	2
2	0
1 Code	
1. ASME Section VIII	
2. CE / VdTUEV	
3. ASME Section VIII + CE / VdTUEV	
2 Medium	
.1 Gases	
.2 Liquids	
.3 Steam	
.0 Steam / Gases / Liquids (valid only for CE / VdTUEV)	

2.0

Code and Medium

Type 441, 442 XXL

How to order – Article numbers

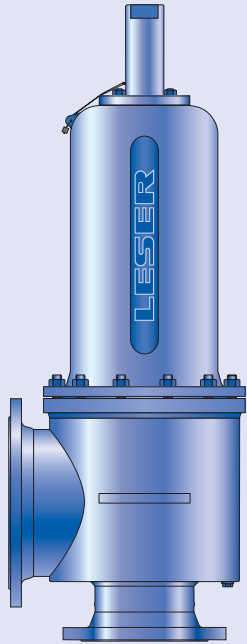

Type 441 XXL
Bolted cap H1
Closed bonnet
Conventional and
balanced bellows design

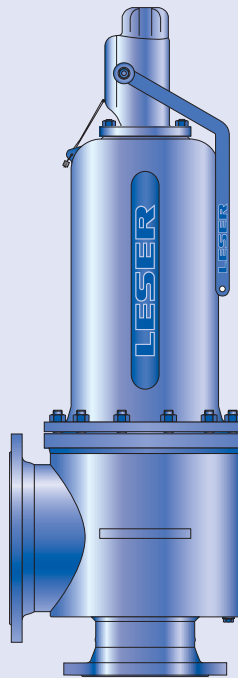

Type 441 XXL
Bolted lifting device H6
Closed bonnet
Conventional and
balanced bellows design

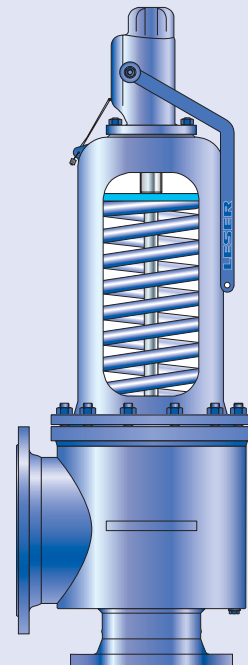

Type 442 XXL
Bolted lifting device H6
Open bonnet
Conventional and
balanced bellows design

How to order – Article numbers

Article numbers			200 x 300	250 x 300	300 x 400	400 x 500
	DN _{I+O}		200 x 300	250 x 300	300 x 400	400 x 500
	Valve size		8" x 12"	10" x 14"	12" x 16"	16" x 20"
	Actual Orifice diameter d ₀ [mm]		165	200	235	295
	Actual Orifice area A ₀ [mm ²]		21382	31416	43374	68349
Body material: 1.0460 / 1.0425 (Carbon steel)						
Bonnet closed	H1	Art.-No. 4412.	4752	4762	4772	4852
	H3	Art.-No. 4412.	–	–	–	–
	H6	Art.-No. 4412.	4754	4764	4774	4784
open	H6	Art.-No. 4422.	4755	4765	4775	4785
Body material: 1.4571 (316Ti)						
Bonnet closed	H1	Art.-No. 4414.	4792	4802	4902	4912
	H6	Art.-No. 4414.	4794	4804	4904	4914

Dimensions and weights

Metric Units

	DN _{I+O}	200 x 300	250 x 350	300 x 400	400 x 500
Valve size		8" x 12"	10" x 14"	12" x 16"	16" x 20"
Actual Orifice diameter d ₀ [mm]		165	200	235	295
Actual Orifice area A ₀ [mm ²]		21382	31416	43374	68349
Weight [kg]		285	335	384	588
	with bellows	289	340	390	595
Center to face [mm]	Inlet a	305	340	330	400
	Outlet b	300	325	394 ¹⁾	477 ¹⁾
Height (H4) [mm]	Standard H max.	1473	1518	1633	1953
	Bellows H max.	1473	1518	1633	1953
Support brackets [mm]	A	470	514	640	800
	B	150	150	180	220
(drilled only on request)	C	Ø 18	Ø 18	Ø 24	Ø 28
	D	305	340	330	400
	E	20	20	20	20

Body material: 1.0460 / 1.0425 (Carbon steel)

DIN Flange²⁾	Inlet	PN 25	PN 16
	Outlet	PN 10	

Body material: 1.4571 (316Ti)

DIN Flange²⁾	Inlet	PN 25	PN 16
	Outlet	PN 10	

- ¹⁾ For pressure rating outlet higher than PN 10 centre to face dimension will change
²⁾ Standard flange rating. For other flange drillings and facings please refer to page 03/14.

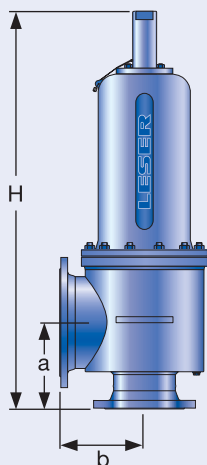

Conventional and balanced bellows design

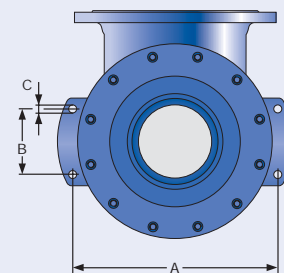
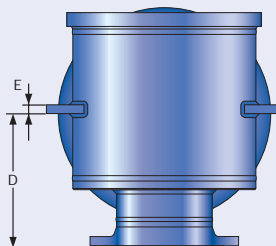

Support brackets

Dimensions and weights

US Units		200 x 300	250 x 350	300 x 400	400 x 500
	DN _{I+O}	200 x 300	250 x 350	300 x 400	400 x 500
	Valve size	8" x 12"	10" x 14"	12" x 16"	16" x 20"
	Actual Orifice diameter d ₀ [inch]	6,5	7,87	9,25	11,61
	Actual Orifice area A ₀ [inch ²]	33,143	48,695	67,229	105,942
Weight					
[lbs]		628	739	847	1297
	with bellows	637	750	860	1312
Center to face					
[inch]	Inlet a	12	13 ³ / ₈	13 (CL300: 13 ³ / ₄)	15 ³ / ₄
	Outlet b	11 ¹³ / ₁₆	12 ¹³ / ₁₆	15 ¹ / ₂	18 ²⁵ / ₃₂
Height (H4)					
[inch]	Standard H max.	58	59 ³ / ₄	64 ⁵ / ₁₆	76 ⁷ / ₈
	Bellows H max.	58	59 ³ / ₄	64 ⁵ / ₁₆	76 ⁷ / ₈
Support brackets					
[inch]	A	18 ¹ / ₂	20 ¹ / ₄	25 ³ / ₁₆	31 ¹ / ₂
	B	5 ²⁹ / ₃₂	5 ²⁹ / ₃₂	7 ³ / ₃₂	8 ²¹ / ₃₂
(drilled only on request)	C	Ø ²⁹ / ₃₂	Ø ²³ / ₃₂	Ø ¹⁵ / ₁₆	Ø ³ / ₃₂
	D	12	13 ³ / ₈	13	15 ³ / ₄
	E	²⁵ / ₃₂	²⁵ / ₃₂	²⁵ / ₃₂	²⁵ / ₃₂

Body material: 1.0460 / 1.0425 (Carbon steel)

ANSI Flange Class¹⁾	Inlet	CL150 or CL300
	Outlet	CL150 or CL300

Body material: 1.4571 (316Ti)

ANSI Flange Class¹⁾	Inlet	CL150 or CL300
	Outlet	CL150 or CL300

¹⁾ Standard flange rating. For other flange drillings and facings please refer to page 03/14.

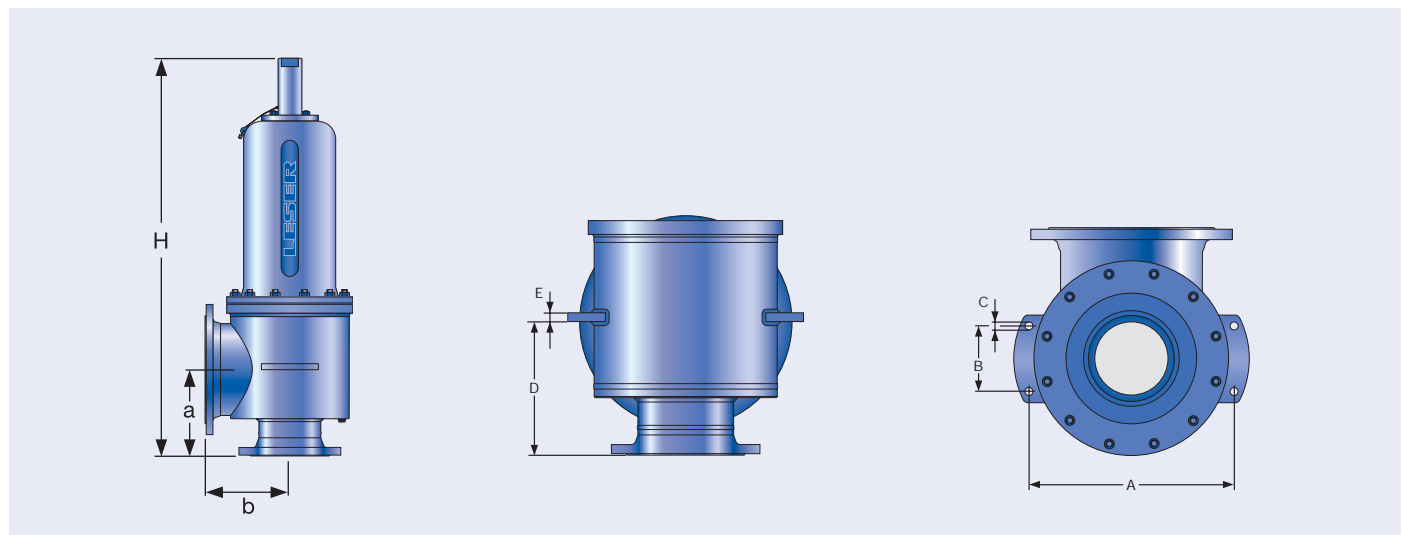

Conventional and balanced bellows design

Support brackets

Pressure temperature ratings

Metric Units

DN _{I+O}	200 x 300	250 x 350	300 x 400	400 x 500	
Valve size	8" x 12"	10" x 14"	12" x 16"	16" x 20"	
Actual Orifice diameter d ₀ [mm]	165	200	235	295	
Actual Orifice area A ₀ [mm ²]	21382	31416	43374	68349	

Body material: 1.0460 / 1.0425 (Carbon steel)

DIN Flange	Inlet		PN 25		PN 16	
	Outlet		PN 10			
Minimum set pressure	p [bar _g]	S/G/L	0,2	0,2	0,2	0,2
Min. set pressure ¹⁾ standard bellows	p [bar _g]	S/G/L	0,2	0,2	0,2	0,2
Min. set pressure low press. bellows	p [bar _g]	S/G/L	-	-	-	-
Maximum set pressure	p [bar _g]	S/G/L	20	13,4	9,25	0,84
Max. set pressure with special spring	p [bar _g]	S/G/L	25	18,5	12	6
Temperature acc. to DIN EN	min. [°C]		-85			
	max. [°C]		+450			
Temperature acc. to ASME	min. [°C]		-29			
	max. [°C]		+427			

Body material: 1.4571 (316Ti)

DIN Flange	Inlet		PN 25		PN 16	
	Outlet		PN 10			
Minimum set pressure	p [bar _g]	S/G/L	0,2	0,2	0,2	0,2
Min. set pressure ¹⁾ standard bellows	p [bar _g]	S/G/L	0,2	0,2	0,2	0,2
Min. set pressure low press. bellows	p [bar _g]	S/G/L	-	-	-	-
Maximum set pressure	p [bar _g]	S/G/L	1,45	0	0	0
Max. set pressure with special spring	p [bar _g]	S/G/L	10	6	3,57	2,3
Temperature acc. to DIN EN	min. [°C]		-196			
	max. [°C]		+550			
Temperature acc. to ASME	min. [°C]		-184			
	max. [°C]		+427			

¹⁾ Min. set pressure standard bellows = Max. set pressure low pressure bellows.

Pressure temperature ratings

US Units						
	DN _{I+O}	200 x 300	250 x 350	300 x 400	400 x 500	
	Valve size	8" x 12"	10" x 14"	12" x 16"	16" x 20"	
	Actual Orifice diameter d ₀ [inch]	6,5	7,87	9,25	11,61	
	Actual Orifice area A ₀ [inch ²]	33,143	48,695	67,229	105,942	
Body material: 1.0460 / 1.0425 (Carbon steel)						
ANSI Flange Class ¹⁾	Inlet		CL150 or CL300			
	Outlet		CL150			
Minimum set pressure	p [psig]	S/G/L	2,9	2,9	2,9	2,9
Min. set pressure ²⁾ standard bellows	p [psig]	S/G/L	2,9	2,9	2,9	2,9
Min. set pressure low press. bellows	p [psig]	S/G/L	-	-	-	-
Maximum set pressure	p [psig]	S/G/L	290	194	134	12
Max. set pressure with special spring	p [psig]	S/G/L	363	268	174	87
Temperature acc. to DIN EN	min. [°F]		-121			
	max. [°F]		+1022			
Temperature acc. to ASME	min. [°F]		-300			
	max. [°F]		+800			
Body material: 1.4571 (316Ti)						
ANSI Flange Class ¹⁾	Inlet		CL150 or CL300			
	Outlet		CL150			
Minimum set pressure	p [psig]	S/G/L	2,9	2,9	2,9	2,9
Min. set pressure ²⁾ standard bellows	p [psig]	S/G/L	2,9	2,9	2,9	2,9
Min. set pressure low press. bellows	p [psig]	S/G/L	-	-	-	-
Maximum set pressure	p [psig]	S/G/L	21	0	0	0
Max. set pressure with special spring	p [psig]	S/G/L	145	87	52	33
Temperature acc. to DIN EN	min. [°F]		-321			
	max. [°F]		+1022			
Temperature acc. to ASME	min. [°F]		-300			
	max. [°F]		+800			

¹⁾ For flange rating class 150 the pressure temperature ratings according to ASME ANSI B 16.34 apply.

²⁾ Min. set pressure standard bellows = Max. set pressure low pressure bellows.

Flange drillings and facings

Flange drillings

	DN _{I+O}	200 x 300	250 x 350	300 x 400	400 x 500	
Valve size		8" x 12"	10" x 14"	12" x 16"	16" x 20"	
Actual Orifice diameter d ₀ [mm]		165	200	235	295	
Actual Orifice area A ₀ [mm ²]		21382	31416	43374	68349	
Body material: 1.0460 / 1.0425 (Carbon steel), 1.4571 (316Ti)						
Inlet	DIN EN 1092	PN 10	H44	H44	H44	H44
		PN 16	H45	H45	*	*
		PN 25	*	*	H46	H46
		PN 40	-	-	-	-
	ASME B16.5	CL150	H64	H64	H64	H64
		CL300	H65	-	-	-
Outlet	DIN EN 1092	PN 10	*	*	*	*
		PN 16	H51	H51	H51	H51
		PN 25	-	-	-	-
		PN 40	-	-	-	-
	ASME B16.5	CL150	H79	H79	H79	H79
		CL300	-	-	-	-

Flange facings

Indication	Standard	Inlet	Outlet	Remark
General				
Flange undrilled	-	H38	H39	
Linde-V-Nut, Form V48	Linde Standard 420-08	J07	J08	Groove: Rz 16
Linde-V-Nut, Form V48A	LWN 313.36	J05	J06	Groove: Rz 4, e.g. with hydrogen
Lens seal form L (without sealing lens)	DIN 2696 LWN 313.35	J11	J12	

Acc. to DIN EN

Flange facing		Inlet	Outlet	Remark	
DIN EN 1092 (new)	DIN 2526 (old)	PN 10 – PN 40	PN 10 – PN 40	Rz-data according to DIN EN 1092 in µm	
see also LWN 313.40)					
Raised face	Type B1	Type C	*	*	Facing: Rz = 12,5 – 50
	Type B2	Type D			
		Type E	L36	L38	Facing: Rz = 3,2 – 12,5
Tongue face C ¹⁾		Tongue face F	H94	H92	Steel flanges only
Groove face D ¹⁾		Groove face N	H93	H91	
Male face E		Male face V13	H96	H98	
Female face F		Female face R13	H97	H99	
O-ring male face G		Male face V14	J01	J02	
O-ring female face H		Female face R14	J03	J04	

Acc. to ASME B16.5

Body material	Inlet	Outlet	Smooth finish ²⁾		Serrated finish		RTJ-groove			
			Inlet	Outlet	Inlet	Outlet	Inlet		Outlet	
			Option code	Option code	Option code	Option code	RTJ-Class	Option code	RTJ-Class	Option code
1.0460/1.0425, 1.4571	all	all	L51	L53	*	*	CL150	H62	CL150	H63

¹⁾ According to DIN EN 1092 groove depths and tongue heights increased compared to the formerly valid DIN (refer to LWN 313.40).

LESER manufactures the groove at flanged valves by milling. If a customer demands a turned surface in the soil of the groove according to DIN 2512 and/or DIN EN 1092-1 an additional option code is necessary: "S01: bottom of the groove drilled". Groove and tongue for PN160 flanges refer to DIN 2512/LWN 313.32.

²⁾ Smooth finish is not defined in the effective standards. For LESER's definition for smooth finish see page 00/07.

For signs and symbols refer to page 00/07

Note: Flange drillings and facings meet always the requirements of mentioned flange standards. Flange thickness and outer diameter may vary from flange standard.

Order information – Spare parts

Spare parts						
	DN _{I+O}	200 x 300	250 x 350	300 x 400	400 x 500	
	Valve size	8" x 12"	10" x 14"	12" x 16"	16" x 20"	
	Actual Orifice diameter d ₀ [mm]	165	200	235	295	
	Actual Orifice area A ₀ [mm ²]	21382	31416	43374	68349	
Disc (Item 7): Metal to metal seat			Material-No. / Art.-No.			
Disc						
with detachable lifting aid	1.4571	230.1549.9000	230.1649.9000	200.2349.9000	200.2449.9000	
Bellows (Item 15): 1.4571			Material-No. / Art.-No.			
Standard bellows	1.4571	400.5449.0000	400.5349.0000	on request	on request	
Conversion kit standard¹⁾		single parts	single parts	on request	on request	
Gasket – Body / bonnet (Item 60)			Material-No. / Art.-No.			
Gasket	Graphite + 1.4401	500.2807.0000	500.2807.0000	500.3507.0000	500.3607.0000	
Ball (Item 61)			Material-No. / Art.-No.			
Ball	Ball Ø [mm]	18	18	18	18	
	1.4401	510.0504.0000	510.0504.0000	510.0504.0000	510.0504.0000	
Split ring (Item 14)			Material-No. / Art.-No.			
Split ring	Spindle ø [mm]	35	35	35	35	
	1.4404	251.1549.0000	251.1549.0000	–	–	
Pin (Item 57)			Material-No. / Art.-No.			
Pin	1.4310	480.1405.0000	480.1405.0000	480.0605.0000	480.0605.0000	

¹⁾ For pressure range see page 03/12 – 03/13.
A conversion kit contains the following components:

Item	Component	No.
8	Guide	1
11	Bonnet spacer	–
12	Spindle	1
15	Bellows	1
22	Lift stopper	1
60	Gasket	3
	Installation instruction LWN 037.05	1

Refer to page 03/04

Available Options

For further information refer to "Accessories and Options", page 99/01

Type 441, 442 XXL

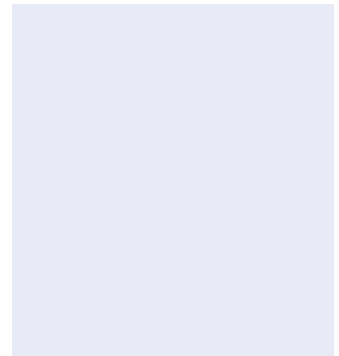
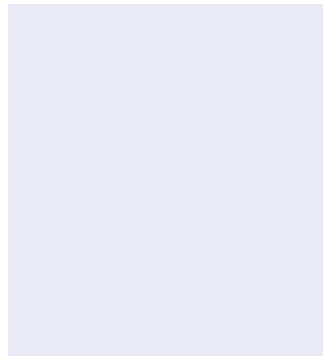
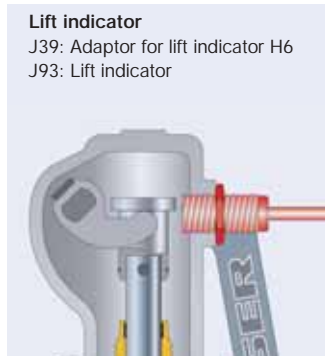
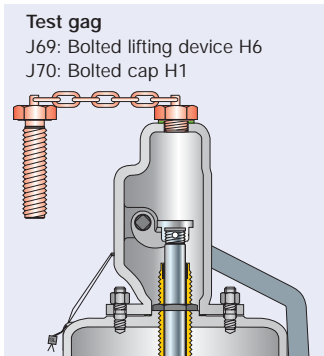
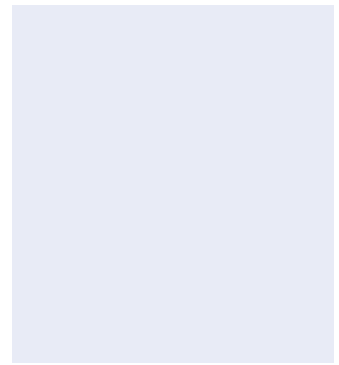
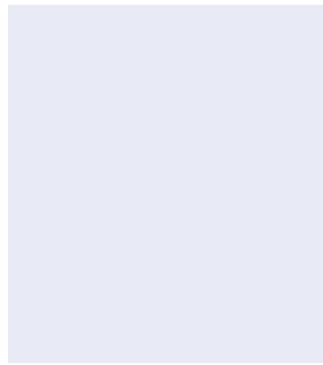
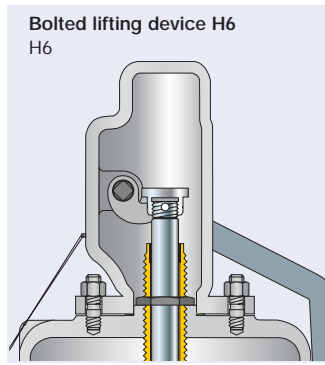
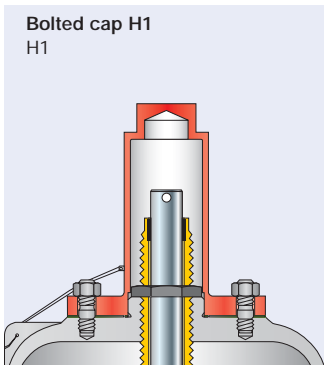
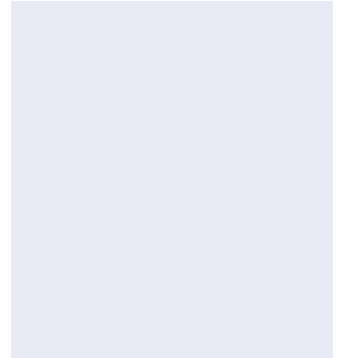
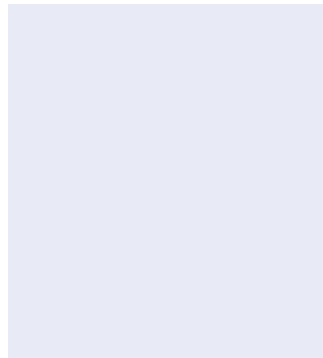
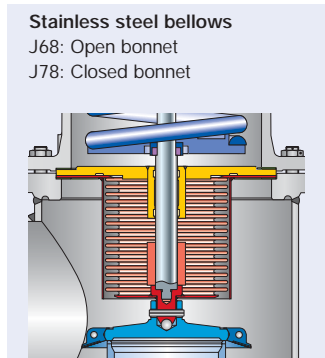
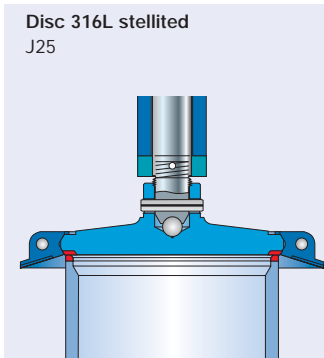
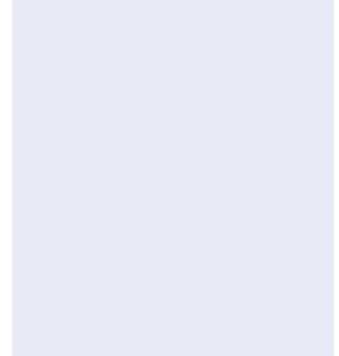
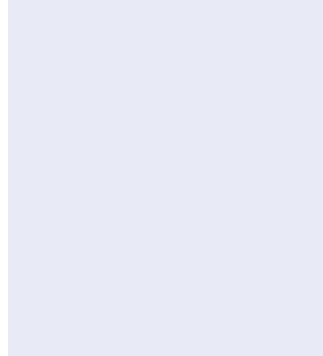
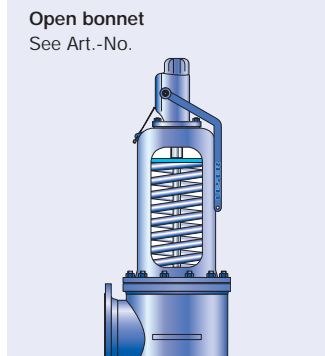
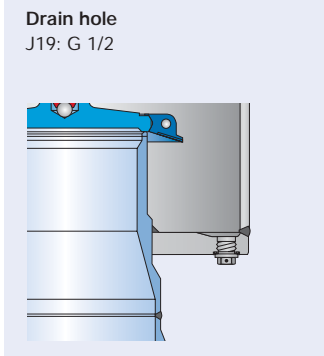

Approvals

Approvals					
	DN ₁₊₀	200 x 300	250 x 350	300 x 400	400 x 500
	Valve size	8" x 12"	10" x 14"	12" x 16"	16" x 20"
	Actual Orifice diameter d ₀ [mm]	1665	200	235	295
	Actual Orifice area A ₀ [mm ²]	21382	31416	43374	68349
Europe		Coefficient of discharge K_{dr}			
DIN EN ISO 4126-1	Approval No.	072020111Z0008/0/08-2			
	S/G	0,75	0,7	0,7	0,7
	L	0,56	0,52	0,52	0,52
Germany		Coefficient of discharge α_w			
AD 2000-Merkblatt A2		TÜV SV 576			
	S/G	0,75	0,7	0,7	0,7
	L	0,56	0,52	0,52	0,52
United States		Coefficient of discharge K			
ASME Sec. VIII	Approval No.	M37044			
	S/G	0,699			
	Approval No.	M37055			
	L	0,521			
Canada		Coefficient of discharge K			
Canada: CRN	Approval No.	OG1182.9C			
	S/G	0,699			
	L	0,521			
China		Coefficient of discharge α_w			
CSBQTS	Approval No.				
	S/G	0,75	0,7	0,7	0,7
	L	0,56	0,52	0,52	0,52
Russia		Coefficient of discharge α_w			
GGTN/ GOSGOTECHNADZOR GOST R	Approval No.	PPC 00-18458			
	S/G	0,75	0,7	0,7	0,7
	L	0,56	0,52	0,52	0,52
Classification societies		Homepage			
Bureau Veritas	BV	www.bureauveritas.com			
Det Norske Veritas	DNV	www.dnv.com			
Germanischer Lloyd	GL	www.gl-group.com			
Lloyd' s register EMEA	LREMEA	www.lr.org			
Registro Italiano Navale	RINA	www.rina.org			
		The valid certification number is changed with every renewal.			
		A sample certificate including the valid certification number can be taken from the homepage of the classification societies.			

Capacities – Steam

Capacities for saturated steam according to AD 2000-Merkblatt A2, based on set pressure plus 10 % overpressure.

Capacities at 1 bar (14,5 psig) and below are based on 0,1 bar (1,45 psig) overpressure.

Metric Units		AD 2000-Merkblatt A2 [kg/h]			
DN _{I+O}		200 x 300	250 x 350	300 x 400	400 x 500
Valve size		8" x 12"	10" x 14"	12" x 16"	16" x 20"
Act. Orifice dia. d ₀ [mm]		165	200	235	295
Act. Orifice area A ₀ [mm ²]		21382	31416	43374	68349
LEO _{S/G} ^{*)} [inch ²]		23,761	34,910	48,198	75,952
Set pressure [bar]	Capacities [kg/h]				
0,1	0	0	0	0	
0,2	7214	0	14633	0	
0,5	11516	16920	23360	36811	
1	16755	24617	33986	53556	
2	26704	39234	54168	85359	
3	35954	52826	72932	114929	
4	48036	65872	90944	143312	
5	57507	78859	108875	171568	
6	66947	91804	126747	199731	
7	76157	104433	144183		
8	85532	117289	161932		
9	94895	130128	179658		
10	104250	142957	197370		
12	122947	168596	232768		
14	141254	193700			
16	159910	219283			
18	178589	244897			
20	197298				
22	197298				
24	234188				

Capacities for saturated steam according to ASME Section VIII (UV), based on set pressure plus 10% overpressure.

Capacities at 2,07 bar (30 psig) and below are based on 0,207 bar (3 psig) overpressure.

US Units		ASME Section VIII [lb/h]			
DN _{I+O}		200 x 300	250 x 350	300 x 400	400 x 500
Valve size		8" x 12"	10" x 14"	12" x 16"	16" x 20"
Act. Orifice dia. d ₀ [inch]		6,5	7,87	9,25	11,61
Act. Orifice area A ₀ [inch ²]		33,14	48,69	67,23	105,94
LEO _{S/G} ^{*)} [inch ²]		23,761	34,910	48,198	75,952
Set pressure [psig]	Capacities [lb/h]				
15	38962	57245	79034	124543	
20	44928	66009	91134	143612	
30	56859	83539	115336	181749	
40	69983	102821	141958	223700	
50	83107	122104	168579	265652	
60	96231	141386	195201	307603	
70	109355	160668	221823	349554	
80	122479	179951	248444	391505	
90	135603	199233	275066		
100	148727	218515	301688		
120	174975	257080	354931		
140	201223	295645	408174		
160	227471	334209	461418		
180	253719	372774			
200	279967	411338			
220	306215	449903			
240	332463	488468			
260	358711	527032			
280	384960				
300	411208				
320	437456				
340	463704				
360	489952				

^{*)} LEO_{S/G} = LESER Effective Orifice steam/gas please refer to page 00/11
How to use capacity-sheets refer to page 00/09

Capacities – Air

Capacities for air according to AD 2000-Merkblatt A2, based on set pressure plus 10 % overpressure at 0 °C and 1013 mbar. Capacities at 1 bar (14,5 psig) and below are based on 0,1 bar (1,45 psig) overpressure.

Metric Units		AD 2000-Merkblatt A2 [m_n^3/h]			
DN _{i+o}		200 x 300	250 x 350	300 x 400	400 x 500
Valve size		8" x 12"	10" x 14"	12" x 16"	16" x 20"
Act. Orifice dia. d_0 [mm]		165	200	235	295
Act. Orifice area. A_0 [mm ²]		21382	31416	43374	68349
LEO _{S/G} ^{*)} [inch ²]		23,761	34,910	48,198	75,952
Set pressure [bar]	Capacities [m_n^3/h]				
0,1	0	0	0	0	
0,2	8354	0	16945	0	
0,5	13528	19876	27441	43242	
1	19970	29341	40509	63835	
2	32251	47384	65420	103090	
3	43930	64544	89110	140423	
4	59080	81016	111853	176261	
5	71093	97489	134596	212100	
6	83106	113962	157339	247939	
7	95118	130435	180082		
8	107131	146908	202824		
9	119144	163381	225567		
10	119144	163381	225567		
12	155182	212799	293796		
14	179207	245745			
16	203232	278690			
18	227258	311636			
20	251283				
22	275308				
24	299334				

Capacities for air according to ASME Section VIII (UV), based on set pressure plus 10 % overpressure at 16 °C (60 °F). Capacities at 2,07 bar (30 psig) and below are based on 0,207 bar (3 psig) overpressure.

US Units		ASME Section VIII [S.C.F.M.]			
DN _{i+o}		200 x 300	250 x 350	300 x 400	400 x 500
Valve size		8" x 12"	10" x 14"	12" x 16"	16" x 20"
Act. Orifice dia. d_0 [inch]		6,5	7,87	9,25	11,61
Act. Orifice area. A_0 [inch ²]		33,14	48,69	67,23	105,94
LEO _{S/G} ^{*)} [inch ²]		23,761	34,910	48,198	75,952
Set pressure [psig]	Capacities [S.C.F.M.]				
15	13879	20392	28153	44365	
20	16004	23514	32464	51158	
30	20254	29758	41085	64743	
40	24929	36627	50568	79687	
50	29604	43496	60051	94631	
60	34280	50365	69534	109575	
70	38955	57234	79018	124519	
80	43630	64102	88501	139463	
90	48305	70971	97984		
100	52980	77840	107467		
120	62330	91578	126433		
140	71680	105315	145400		
160	81030	119053	164366		
180	90380	132791			
200	99731	146528			
220	109081	160266			
240	118431	174003			
260	127781	187741			
280	137131				
300	146481				
320	155831				
340	165182				
360	174532				

^{*)} LEO_{S/G} = LESER Effective Orifice steam/gas please refer to page 00/11
How to use capacity-sheets refer to page 00/09

Capacities – Water

Capacities for water according to AD 2000-Merkblatt A2, based on set pressure plus 10 % overpressure at 20 °C (68 °F). Capacities at 1 bar (14,5 psig) and below are based on 0,1 bar (1,45 psig) overpressure.

Metric Units		AD 2000-Merkblatt A2 [10 ³ kg/h]			
DN _{I+O}		200 x 300	250 x 350	300 x 400	400 x 500
Valve size		8" x 12"	10" x 14"	12" x 16"	16" x 20"
Act. Orifice dia. d ₀ [mm]		165	200	235	295
Act. Orifice area A ₀ [mm ²]		21382	31416	43374	68349
LEO _L ^{*)} [inch ²]		26,565	39,031	53,887	84,916
Set pressure [bar]	Capacities [10 ³ kg/h]				
0,1	272	372	513	808	
0,2	334	455	628	990	
0,5	472	644	889	1400	
1	639	871	1203	1896	
2	903	1232	1702	2681	
3	1106	1509	2084	3284	
4	1278	1743	2406	3792	
5	1428	1949	2690	4240	
6	1565	2135	2947	4644	
7	1690	2306	3183		
8	1807	2465	3403		
9	1916	2614	3610		
10	2020	2756	3805		
12	2213	3019	4168		
14	2390	3261			
16	2555	3486			
18	2710	3697			
20	2857				
22	2996				
24	3129				

Capacities for water according to ASME Section VIII (UV), based on set pressure plus 10 % overpressure at 21 °C (70 °F). Capacities at 2,07 bar (30 psig) and below are based on 0,207 bar (3 psig) overpressure.

US Units		ASME Section VIII [US-G.P.M.]			
DN _{I+O}		200 x 300	250 x 350	300 x 400	400 x 500
Valve size		8" x 12"	10" x 14"	12" x 16"	16" x 20"
Act. Orifice dia. d ₀ [inch]		6,5	7,87	9,25	11,61
Act. Orifice area A ₀ [inch ²]		33,14	48,69	67,23	105,94
LEO _L ^{*)} [inch ²]		26,565	39,031	53,887	84,916
Set pressure [psig]	Capacities [US-G.P.M.]				
15	2780	4084	5639	8886	
20	3142	4617	6374	10044	
30	3764	5530	7635	12031	
40	4346	6386	8816	13893	
50	4859	7139	9857	15532	
60	5323	7821	10797	17015	
70	5749	8447	11662	18378	
80	6146	9031	12468	19647	
90	6519	9578	13224		
100	6872	10096	13939		
120	7528	11060	15270		
140	8131	11946	16493		
160	8692	12771	17632		
180	9220	13546			
200	9718	14279			
220	10193	14975			
240	10646	15641			
260	11081	16280			
280	11499				
300	11902				
320	12293				
340	12671				
360	13039				

^{*)} LEO_L = LESER Effective Orifice liquids please refer to page 00/12
How to use capacity-sheets refer to page 00/09

Determination of coefficient of discharge in case of lift restriction or back pressure

- h = Lift [mm]
- d_0 = Flow diameter [mm] of selected safety valve, refer to table article numbers
- h/d_0 = Ratio of lift / flow diameter
- p_{a0} = Back pressure [bar_a]
- p_0 = Set pressure [bar_a]
- p_{a0}/p_0 = Ratio of back pressure / set pressure
- K_{dr} = Coefficient of discharge acc. to DIN EN ISO 4126-1
- α_w = Coefficient of discharge acc. to AD 2000-Merkblatt A2
- K_b = Back pressure correction factor acc. to API 520 topic 3.3

Diagram for evaluation of ratio of lift / flow diameter (h/d_0) in reference to the coefficient of discharge (K_{dr}/α_w)

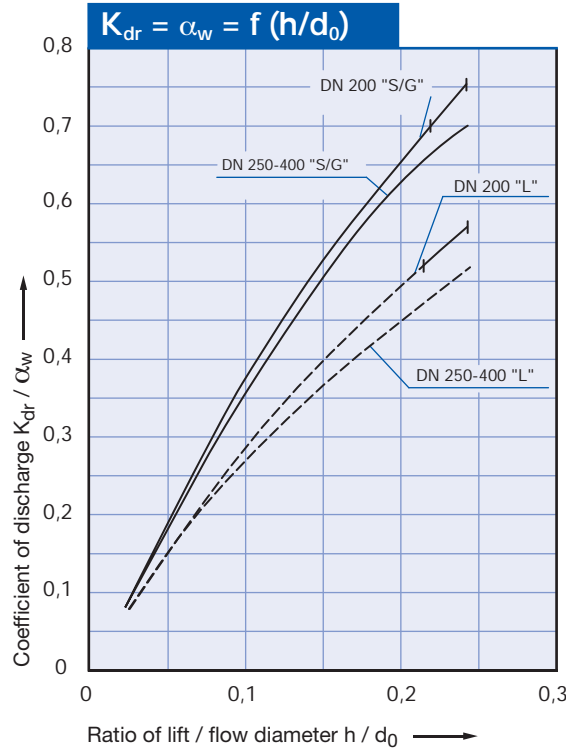
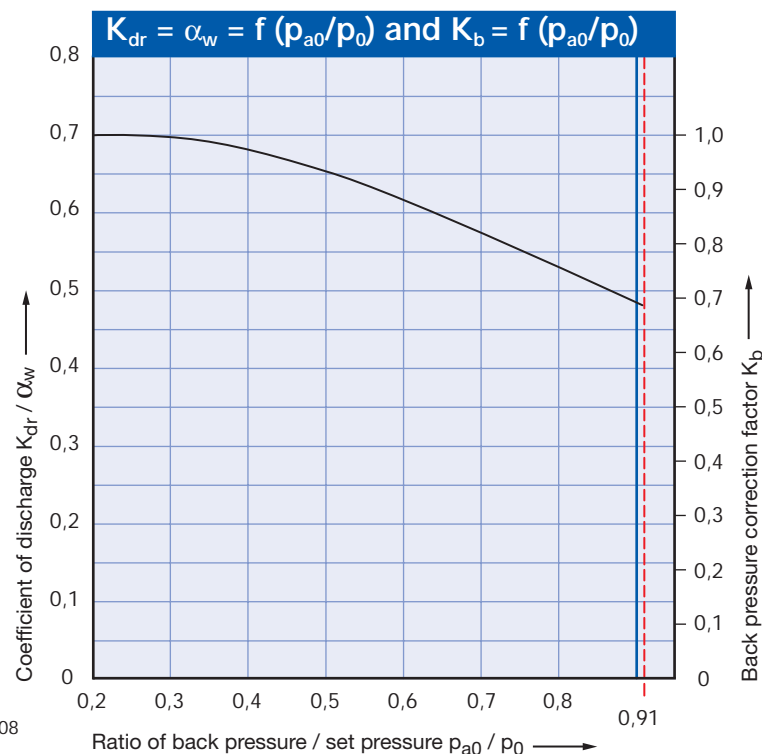

Diagram for evaluation of coefficient of discharge (K_{dr}/α_w) or K_b in reference to the ratio of back pressure / set pressure (p_{a0}/p_0)



How to use please refer to page 00/08

Type 444 DIN

Type 444 DIN
Packed lever H4
Closed bonnet
Conventional design

Flanged Safety Relief Valves – spring loaded

Contents Chapter/Page

Materials	
• Conventional design	04/02
How to order	
• Numbering system	04/04
• Article numbers	04/06
Dimensions and weights	
• Metric Units	04/07
• US Units	04/07
Pressure temperature ratings	
• Metric Units	04/08
• US Units	04/08
Flange drillings and facings	04/09
Order information – Spare parts	04/10
Available options	04/11
Approvals	04/12
Capacities	
• Steam [Metric Units + US Units]	04/13
• Air [Metric Units + US Units]	04/14
• Water [Metric Units + US Units]	04/15
Determination of coefficient of discharge K_{dr}/α_w	04/16

Conventional design

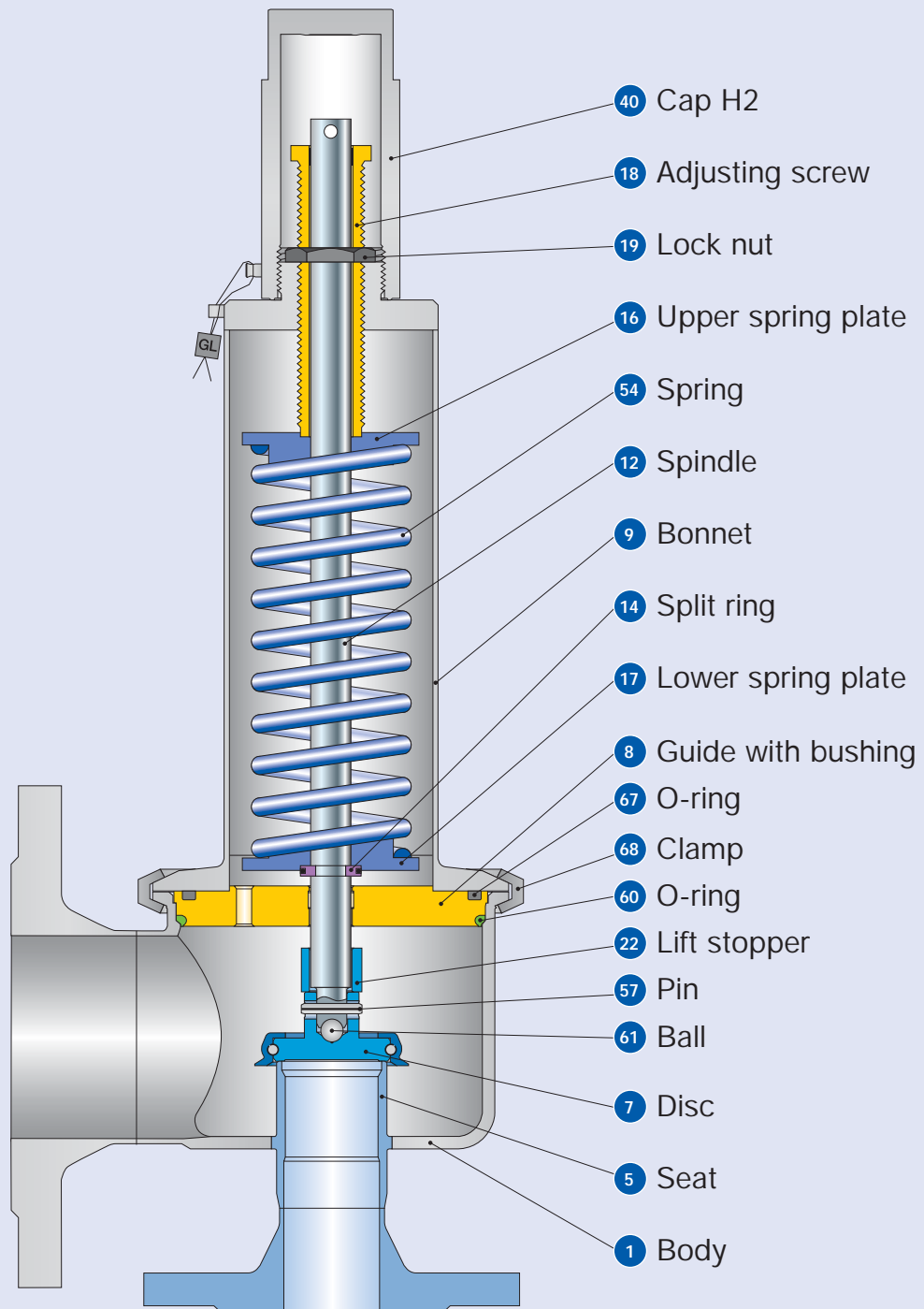

Conventional design

Materials		
Item	Component	Type 4444 DIN
1	Body	1.4404
		316L
5	Seat	1.4404
		316L
7	Disc	1.4404
		316L
8	Guide	1.4404
		316L
	with bushing	PTFE +15% Glas --
9	Bonnet	1.4404
		316L
12	Spindle	1.4404
		316L
14	Split ring	1.4404
		316L
16 / 17	Spring plate	1.4404
		316L
18	Adjusting screw with bushing	1.4404, PTFE + 15% Glas
		316L, PTFE + 15% Glas
19	Lock nut	1.4404
		316L
22	Lift stopper	1.4404
		316L
40	Cap H2	1.4404
		316L
54	Spring	1.4310
		Stainless steel
57	Pin	1.4310
		302
60	O-ring	EPDM-FDA
		--
61	Ball	1.4401
		316
67	O-ring	EPDM-FDA
		--
68	Clamp	1.4401
		316

Please notice:

- Modifications reserved by LESER.
- LESER can upgrade materials without notice.
- Every part can be replaced by other material acc. to customer specification.

How to order – Numbering system

1

Article Number

1	2	3	4
444	4	364	4

1 Valve Type 444 DIN
Type 444 – with closed bonnet

2 Material code

Code	Body material
4	1.4404 (316L)

3 Valve code
Identifies valve size and body material, refer to page 04/09.

4

Code	Lifting lever	
	2	screwed cap
4	packed lever	H4

4444.3644

Article No.

2

Set Pressure

Please state unit (in gauge)!

Please do not exceed the pressure range defined in the spring charts.

5 barg

Set Pressure

3

Connections

Please refer to page 04/09

H45

Connections

4 Options

Type 444 DIN	Option code
• O-ring-disc	
CR	"K" J21
EPDM	"D" J22
FKM	"L" J23
FFKM	"C" J20
• Detachable lifting aid	J26
• Adaptor for lift indicator	
– Bonnet	J38
– H4	J39
• Lift indicator	J93
• Test gag	
- cap	H2 J70
- packed lever	H4 J69
• Seat 1.4404 / 316L stellited	L61

Option code applies only if not standard

J22

Options

5 Documentation

Please select requested documentation:

Inspections, tests:	Option Code
DIN EN 10204-3.2: TÜV-Nord Certificate for test pressure	M33
LESER Certificate for Global Application	H03
- Inspection certificate 3.1 acc. to DIN EN 10204	
- Declaration of conformity acc. to PED 97/23/EC	
Material test certificate:	
DIN EN 10204-3.1	
Part	Option code
Body	H01
Bonnet	L30
Cap / lever cover	L31
Disc	L23

H01 L30

Documentation

6 Code and Medium

1	2
2	0
1 Code	
1. ASME Section VIII	
2. CE / VdTUEV	
3. ASME Section VIII + CE / VdTUEV	
2 Medium	
.1 Gases	
.2 Liquids	
.3 Steam	
.0 Steam / Gases / Liquids (valid only for CE / VdTUEV)	

2.0

Code and Medium

Type 444 DIN

How to order – Article numbers

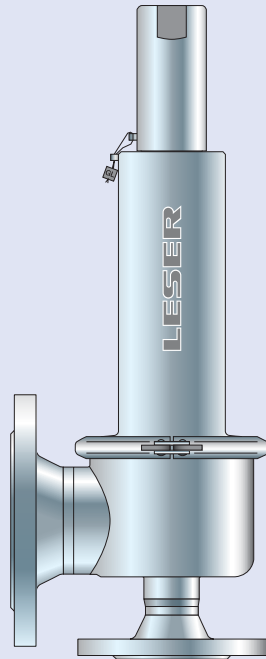

Type 444
Cap H2
Closed bonnet
Conventional design

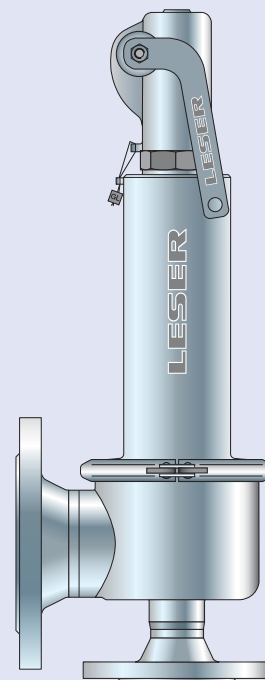

Type 444
Packed lever H4
Closed bonnet
Conventional design

Article numbers

DN _i	25	25	50	65	80	80
DN _o	50	80	80	100	100	100
Actual Orifice diameter d ₀ [mm]	23	37	46	60	74	74
Actual Orifice area A ₀ [mm ²]	416	1075	1662	2827	4301	4301
Set pressure range S/G/L [bar _g]	see page 04/08				0,1 – 6,8	6,81 – 16
Set pressure range S/G/L [psig]	see page 04/08				1,5 – 98,6	98,61 – 232

Body material: 1.4404 (316L)

Bonnet	H2	Art.-No. 4444.	3642	3662	3672	3682	3692	3702
closed	H4	Art.-No. 4444.	3644	3664	3674	3684	3694	3704

Dimensions and weights

Metric Units

DN _i	25	40	50	65	80	80
DN _o	50	80	80	100	100	100
Actual Orifice diameter d ₀ [mm]	23	37	46	60	74	74
Actual Orifice area A ₀ [mm ²]	416	1075	1662	2827	4301	4301
Set pressure range S/G/L [bar _g]	see page 04/08				0,1 – 6,8	6,81 – 16

Weight [kg]	7	13	14	23	24	24
Center to face [mm]	Inlet a	85	110	110	125	125
	Outlet b	90	128	128	160	160
Height (H4) [mm] Standard H max.	308	519	519	631	631	631

Body material: 1.4404 (316L)

DIN Flange	Inlet	PN 16
	Outlet	PN 16

US Units

DN _i	25	40	50	65	80	80
DN _o	50	80	80	100	100	100
Actual Orifice diameter d ₀ [inch]	0,91	1,46	1,81	2,36	2,91	2,91
Actual Orifice area A ₀ inch ²	0,644	1,667	2,576	4,383	6,666	6,666
Set pressure range S/G/L [psig]	see page 04/08				1,5 – 98,6	98,61 – 232

Weight [lbs]	16	29	31	51	53	53
Center to face [inch]	Inlet a	3 ³ / ₈	4 ⁵ / ₁₆	4 ⁵ / ₁₆	4 ¹⁵ / ₁₆	4 ¹⁵ / ₁₆
	Outlet b	3 ¹ / ₂	5 ¹ / ₁₆	5 ¹ / ₁₆	6 ⁵ / ₁₆	6 ⁵ / ₁₆
Height (H4) [inch] Standard H max.	12 ¹ / ₈	20 ⁷ / ₁₆	20 ⁷ / ₁₆	20 ¹³ / ₁₆	20 ¹³ / ₁₆	20 ¹³ / ₁₆

Body material: 1.4404 (316L)

DIN Flange	Inlet	PN 16
	Outlet	PN 16

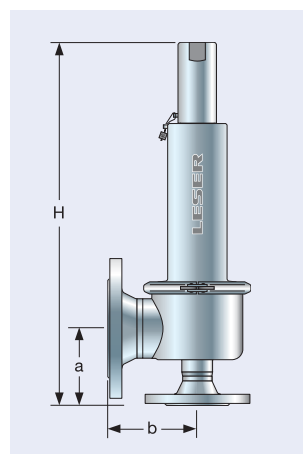

Conventional design

Pressure temperature ratings

Metric Units							
	DN _i	25	40	50	65	80	80
	DN _o	50	80	80	100	100	100
	Actual Orifice diameter d ₀ [mm]	23	37	46	60	74	74
	Actual Orifice area A ₀ [mm ²]	416	1075	1662	2827	4301	4301
Body material: 1.4404 (316L)							
DIN Flange	Inlet	PN 16					
	Outlet	PN 16					
Minimum set pressure	p [bar _g] S/G/L	0,1	0,1	0,1	0,1	0,1	6,81
Maximum set pressure	p [bar _g] S/G/L	16	16	16	16	6,8	16
Temperature acc. to DIN EN	min. [°C]	-45					
	max. [°C]	+200					
Temperature acc. to ASME	min. [°C]	-45					
	max. [°C]	+200					

US Units							
	DN _i	25	40	50	65	80	80
	DN _o	50	80	80	100	100	100
	Actual Orifice diameter d ₀ [inch]	0,91	1,46	1,81	2,36	2,91	2,91
	Actual Orifice area A ₀ [inch ²]	0,644	1,667	2,576	4,383	6,666	6,666
Body material: 1.4404 (316L)							
DIN Flange	Inlet	PN 16					
	Outlet	PN 16					
Minimum set pressure	p [psig] S/G/L	1,5	1,5	1,5	1,5	1,5	98,61
Maximum set pressure	p [psig] S/G/L	232	232	232	232	98,6	232
Temperature acc. to DIN EN	min. [°F]	-49					
	max. [°F]	+392					
Temperature acc. to ASME	min. [°F]	-49					
	max. [°F]	+392					

Flange drillings and facings

Flange drillings		DN _i	25	40	50	65	80	
	DN _o	50	80	80	100	100		
	Valve size	1" x 2"	1 1/2" x 3"	2" x 3"	2 1/2" x 4"	3" x 4"		
	Actual Orifice diameter d ₀ [mm]	23	37	46	60	74		
	Actual Orifice area A ₀ [mm ²]	416	1075	1662	2827	4301		
Body material: 1.4404 (316L)								
Inlet	DIN EN 1092	PN 10	-	-	-	-	-	
		PN 16	*	*	*	*	*	
		PN 25	-	-	-	-	-	
		PN 40	-	-	-	-	-	
	ASME B16.5	CL150	Please use Type 444 ANSI					
		CL300	Please use Type 444 ANSI					
Outlet	DIN EN 1092	PN 10	-	-	-	-	-	
		PN 16	*	*	*	*	*	
		PN 25	-	-	-	-	-	
		PN 40	-	-	-	-	-	
	ASME B16.5	CL150	Please use Type 444 ANSI					
		CL300	Please use Type 444 ANSI					

Flange facings		Standard	Inlet	Outlet	Remark	
General						
Flange undrilled	-		H38	H39		
Lens seal form L (without sealing lens)	DIN 2696 LWN 313.35		J11	J12		
Acc. to DIN EN						
Flange facing			Inlet	Outlet	Remark	
DIN EN 1092 (new)		DIN 2526 (old)	PN 10 – PN 40	PN 10 – PN 40	Rz-data according to DIN EN 1092 in µm	
see also LWN 313.40)						
Raised face	Type B1	Type C	*	*	Facing: Rz = 12,5 – 50	
	Type B2	Type E	L36	L38	Facing: Rz = 3,2 – 12,5	
Tongue face C ¹⁾		Tongue face F	H94	H92	Steel flanges only	
Groove face D ¹⁾		Groove face N	H93	H91		
Male face E		Male face V13	H96	H98		
Female face F		Female face R13	H97	H99		
O-ring male face G		Male face V14	J01	J02		
O-ring female face H		Female face R14	J03	J04		
Acc. to ASME B16.5						
Please use Type 444 ANSI						

¹⁾ According to DIN EN 1092 groove depths and tongue heights increased compared to the formerly valid DIN (refer to LWN 313.40). LESER manufactures the groove at flanged valves by milling. If a customer demands a turned surface in the soil of the groove according to DIN 2512 and/or DIN EN 1092-1 an additional option code is necessary: "S01: bottom of the groove drilled". Groove and tongue for PN160 flanges refer to DIN 2512/LWN 313.32.
²⁾ Smooth finish is not defined in the effective standards. For L ESER's definition for smooth finish see page 00/07.

For signs and symbols refer to page 00/07

Note: Flange drillings and facings meet always the requirements of mentioned flange standards. Flange thickness and outer diameter may vary from flange standard.

Order information – Spare parts

Spare parts								
	DN _i	25	40	50	65	80	80	
	DN _o	50	80	80	100	100	100	
	Actual Orifice diameter d ₀ [mm]	23	37	46	60	74	74	
	Actual Orifice area A ₀ [mm ²]	416	1075	1662	2827	4301	4301	
	Set pressure range S/G/L [bar _g]	see page 04/08				0,1 – 6,8	6,81 – 16	
	Set pressure range S/G/L [psig]					1,5 – 98,6	98,61 – 232	
Disc (Item 7): Metal to metal seat				Material-No. / Art.-No.				
Disc	detachable lifting aid	1.4404	225.4149.9000	225.4349.9000	225.4449.9000	225.4549.9000	225.4649.9000	225.4649.9000
O-ring (Item 60 + 67)				Material-No. / Art.-No.				
O-ring	EPDM	"D"	502.0600.3041	502.1130.4041	502.1130.4041	502.1580.5041	502.1580.5041	502.1580.5041
	FKM	"L"	502.0600.3071	502.1130.4071	502.1130.4071	502.1580.5071	502.1580.5071	502.1580.5071
Ball (Item 61)				Material-No. / Art.-No.				
Ball	ø [mm]	6	9	9	12	12	12	
	1.4401	510.0104.0000	510.0204.0000	510.0204.0000	510.0304.0000	510.0304.0000	510.0304.0000	
Pin (Item 57)				Material-No. / Art.-No.				
Pin	1.4310	480.0505.0000	480.0705.0000	480.0705.0000	480.1005.0000	480.1005.0000	480.1005.0000	

Available Options

For further information refer to "Accessoires and Options", page 99/01

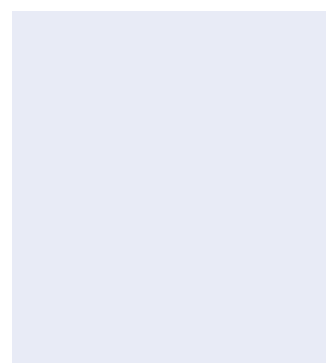
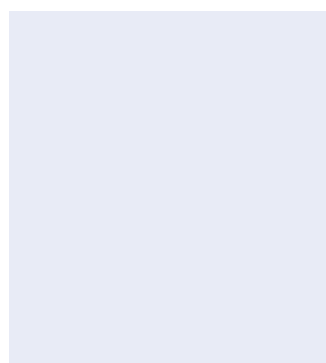
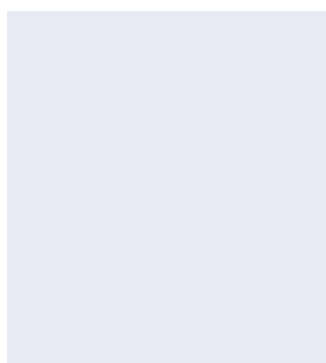
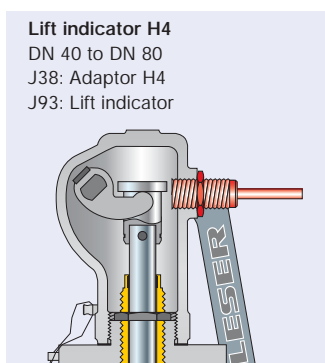
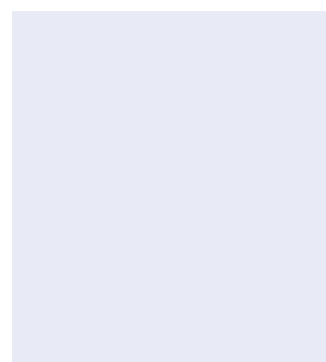
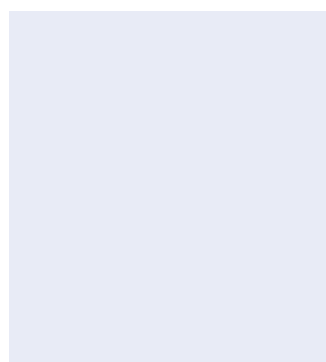
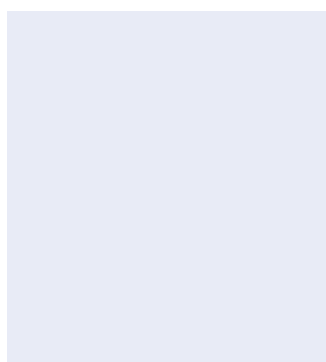
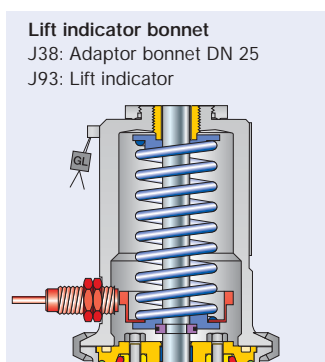
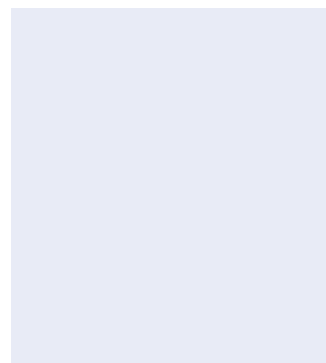
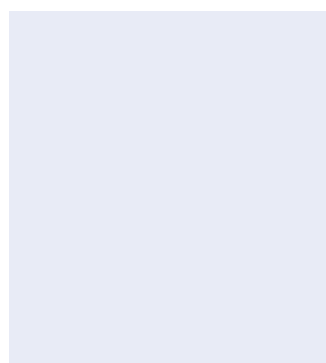
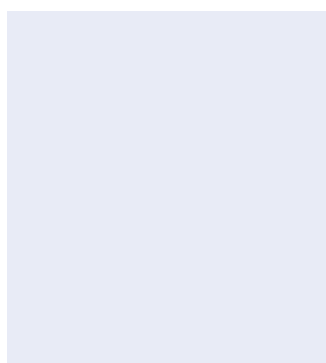
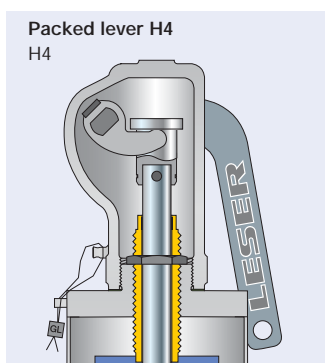
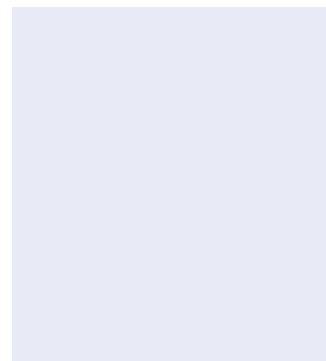
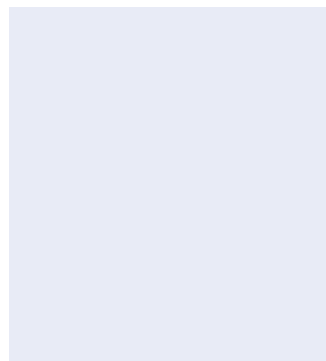
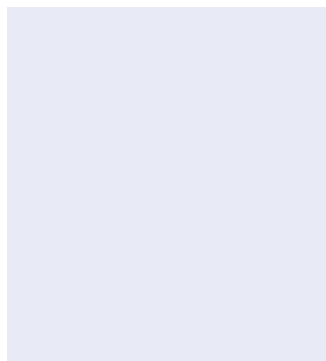
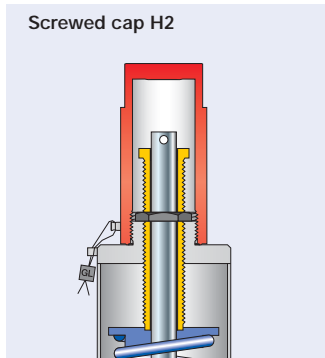

Type 444 DIN

Approvals

Approvals							
	DN _i	25	40	50	65	80	80
	DN _o	50	80	80	100	100	100
	Actual Orifice diameter d ₀ [mm]	23	37	46	60	74	74
	Actual Orifice area A ₀ [mm ²]	416	1075	1662	2827	4301	4301
	Set pressure range S/G/L [bar _g]	see page 04/08				0,1 – 6,8	6,81 – 16
	Set pressure range S/G/L [psig]					1,5 – 98,6	98,61 – 232
Europe		Coefficient of discharge K_{dr}					
DIN EN ISO 4126-1	Approval No.	072020111Z0008/0/08-2					
	S/G	0,7					0,55
	L	0,48					0,48
Germany		Coefficient of discharge α_w					
AD 2000-Merkblatt A2	Approval No.	TÜV SV 576					
	S/G	0,7					0,55
	L	0,48					0,48
United States		Coefficient of discharge K					
ASME Sec. VIII	Approval No.	M37044					–
	S/G	0,699					–
	Approval No.	M37055					M37055
	L	0,521					0,521
Canada		Coefficient of discharge K					
Canada: CRN	Approval No.	OG1182.9C					
	S/G	0,699					–
	L	0,521					0,521
China		Coefficient of discharge α_w					
CSBQTS	Approval No.						
	S/G	0,7					0,55
	L	0,48					0,48
Russia		Coefficient of discharge α_w					
GGTN/ GOSGOTECHNADZOR GOST R	Approval No.	PPC 00-18458					
	S/G	0,7					0,55
	L	0,48					0,48
Classification societies							
		on request					

Capacities – Steam

Capacities for saturated steam according to AD 2000-Merkblatt A2, based on set pressure plus 10 % overpressure.
Capacities at 1 bar (14,5 psig) and below are based on 0,1 bar (1,45 psig) overpressure.

Metric Units		AD 2000-Merkblatt A2 [kg/h]					
DN _i		25	40	50	65	80	80
DN _o		50	80	80	100	100	100
Act. Orifice dia. d ₀ [mm]		23	37	46	60	74	74
Act. Orifice area A ₀ [mm ²]		416	1075	1662	2827	4301	4301
LEO _{S/G} ^{*)} [inch ²]		0,462	1,195	1,847	3,142	4,779	4,779
Set pressure S/G [bar _g]						0,1–6,8	6,81–16
Set pressure [bar]	Capacities [kg/h]						
0,1	112	274	405	720	1093		
0,2	144	353	524	927	1417		
0,5	223	546	822	1434	2221		
1	324	790	1209	2086	3262		
2	529	1285	2002	3413	5377		
3	699	1761	2770	4695	7237		
4	872	2256	3487	5932	9023		
5	1043	2700	4174	7101	10801		
6	1215	3143	4858	8266	12573		
7	1382	3575	5526	9402		11237	
8	1552	4015	6206	10559		12619	
9	1721	4455	6885	11714		14000	
10	1891	4894	7564	12868		15380	
12	2230	5772	8922	15179		18141	
14	2562	6631	10249	17437		20840	
16	2901	7507	11603	19740		23593	

Capacities for saturated steam according to ASME Section VIII (UV), based on set pressure plus 10% overpressure.
Capacities at 2,07 bar (30 psig) and below are based on 0,207 bar (3 psig) overpressure.

US Units		ASME Section VIII [lb/h]					
DN _i		25	40	50	65	80	80
DN _o		50	80	80	100	100	100
Act. Orifice dia. d ₀ [inch]		0,91	1,46	1,81	2,36	2,91	2,91
Act. Orifice area A ₀ [inch ²]		0,644	1,667	2,576	4,383	6,666	6,666
LEO _{S/G} ^{*)} [inch ²]		0,462	1,195	1,847	3,142	4,779	4,779
Set pressure S/G [psig]						1,5–98,6	98,61–232
Set pressure [psig]	Capacities [lb/h]						
15	758	1962	3032	5159	7847		
20	874	2262	3496	5948	9047		
30	1106	2862	4423	7525	11447		
40	1361	3522	5443	9261	14087		
50	1616	4182	6463	10996	16726		
60	1871	4842	7483	12732	19366		
70	2126	5501	8503	14467	22006		
80	2381	6161	9523	16202	24646		
90	2636	6821	10543	17938	27285		
100	2891	7481	11563	19673	29925		
120	3401	8801	13604	23144		35205	
140	3911	10121	15644	26615		40484	
160	4421	11441	17684	30086		45764	
180	4931	12761	19724	33557		51043	
200	5441	14081	21764	37027		56323	
220	5951	15401	23804	40498		61602	
230	6206	16060	24824	42234		64242	

*) LEO_{S/G} = LESER Effective Orifice steam/gas please refer to page 00/11
How to use capacity-sheets refer to page 00/09

Capacities – Air

Capacities for air according to AD 2000-Merkblatt A2, based on set pressure plus 10 % overpressure at 0 °C and 1013 mbar. Capacities at 1 bar (14,5 psig) and below are based on 0,1 bar (1,45 psig) overpressure.

Capacities for air according to ASME Section VIII (UV), based on set pressure plus 10 % overpressure at 16 °C (60 °F). Capacities at 2,07 bar (30 psig) and below are based on 0,207 bar (3 psig) overpressure.

Metric Units		AD 2000-Merkblatt A2 [m_n^3/h]					
DN _i		25	40	50	65	80	80
DN _o		50	80	80	100	100	100
Act. Orifice dia. d_o [mm]		23	37	46	60	74	74
Act. Orifice area A_o [mm ²]		416	661	1075	1662	2827	6648
LEO _{S/G} ³⁾ [inch ²]		0,462	1,195	1,847	3,142	4,779	4,779
Set pressure S/G [bar _g]						0,1–6,8	6,81–16
Set pressure [bar]	Capacities [m_n^3/h]						
0,1	129	316	466	829	1257		
0,2	167	409	607	1073	1640		
0,5	262	640	964	1683	2607		
1	386	941	1440	2484	3884		
2	639	1551	2416	4119	6489		
3	853	2150	3382	5732	8835		
4	1071	2772	4284	7289	11088		
5	1289	3335	5155	8771	13341		
6	1506	3899	6026	10252	15594		
7	1724	4462	6897	11733		14023	
8	1942	5025	7767	13214		15793	
9	2159	5588	8638	14696		17564	
10	2377	6152	9509	16177		19334	
12	2812	7278	11250	19140		22875	
14	3248	8405	12991	22102		26416	
16	3683	9532	14733	25065		29956	

US Units		ASME Section VIII [S.C.F.M.]					
DN _i		25	40	50	65	80	80
DN _o		50	80	80	100	100	100
Act. Orifice dia. d_o [inch]		0,91	1,46	1,81	2,36	2,91	2,91
Act. Orifice area A_o [inch ²]		0,644	1,667	2,576	4,383	6,666	6,666
LEO _{S/G} ³⁾ [inch ²]		0,462	1,195	1,847	3,142	4,779	4,779
Set pressure S/G [psig]						1,5–98,6	98,61–232
Set pressure [psig]	Capacities [S.C.F.M.]						
15	269	697	1077	1832	2786		
20	310	803	1241	2112	3212		
30	393	1016	1571	2672	4064		
40	483	1250	1933	3288	5002		
50	574	1485	2295	3904	5939		
60	664	1719	2657	4521	6876		
70	755	1953	3019	5137	7814		
80	845	2188	3381	5753	8751		
90	936	2422	3744	6369	9688		
100	1026	2656	4106	6985	10625		
120	1208	3125	4830	8218		12500	
140	1389	3594	5555	9450		14375	
160	1570	4062	6279	10682		16249	
180	1751	4531	7003	11915		18124	
200	1932	5000	7728	13147		19998	
220	2113	5468	8452	14380		21873	
230	2204	5703	8814	14996		22810	

³⁾ LEO_{S/G} = LESER Effective Orifice steam/gas please refer to page 00/11
How to use capacity-sheets refer to page 00/09

Capacities – Water

Capacities for water according to AD 2000-Merkblatt A2, based on set pressure plus 10 % overpressure at 20 °C (68 °F). Capacities at 1 bar (14,5 psig) and below are based on 0,1 bar (1,45 psig) overpressure.

Capacities for water according to ASME Section VIII (UV), based on set pressure plus 10 % overpressure at 21 °C (70 °F). Capacities at 2,07 bar (30 psig) and below are based on 0,207 bar (3 psig) overpressure.

Metric Units		AD 2000-Merkblatt A2 [10 ³ kg/h]					
DN _i		25	40	50	65	80	80
DN _o		50	80	80	100	100	100
Act. Orifice dia. d ₀ [mm]		23	37	46	60	74	74
Act. Orifice area A ₀ [mm ²]		416	1075	1662	2827	4301	4301
LEO _L ¹⁾ [inch ²]		0,516	1,336	2,065	3,513	5,343	5,343
Set pressure L [bar _g]						0,1–6,8	6,81–16
Set pressure [bar]		Capacities [10 ³ kg/h]					
0,1		4,54	11,8	18,2	30,9	47	
0,2		5,56	14,4	22,2	37,8	57,6	
0,5		7,87	20,4	31,5	53,5	81,4	
1		10,6	27,6	42,6	72,5	110	
2		15,1	39	60,2	102	156	
3		18,4	47,7	73,8	126	191	
4		21,3	55,1	85,2	145	220	
5		23,8	61,6	95,3	162	246	
6		26,1	67,5	104	178	270	
7		28,2	72,9	113	192		292
8		30,1	77,9	120	205		312
9		31,9	82,7	128	217		331
10		33,7	87,2	135	229		349
12		36,9	95,5	148	251		382
14		39,8	103	159	271		412
16		42,6	110	170	290		441

US Units		ASME Section VIII [US-G.P.M.]					
DN _i		25	40	50	65	80	80
DN _o		50	80	80	100	100	100
Act. Orifice dia. d ₀ [inch]		0,91	1,46	1,81	2,36	2,91	2,91
Act. Orifice area A ₀ [inch ²]		0,644	1,667	2,576	4,383	6,666	6,666
LEO _L ¹⁾ [inch ²]		0,516	1,336	2,065	3,513	5,343	5,343
Set pressure L [psig]						1,5–98,6	98,61–232
Set pressure [psig]		Capacities [US-G.P.M.]					
15		54,1	140	216	368	560	
20		61,1	158	245	416	633	
30		73,2	190	293	498	758	
40		84,6	219	338	576	875	
50		94,6	245	378	643	979	
60		104	268	414	705	1072	
70		112	290	447	761	1158	
80		120	310	478	814	1238	
90		127	328	507	863	1313	
100		134	346	535	910	1384	
120		146	379	586	997		1516
140		158	409	633	1077		1638
160		169	438	677	1151		1751
180		179	464	718	1221		1857
200		189	489	756	1287		1958
220		198	513	793	1350		2053
230		203	525	811	1380		2099

¹⁾ LEO_L = LESER Effective Orifice liquids please refer to page 00/12
How to use capacity-sheets refer to page 00/09

Determination of coefficient of discharge in case of lift restriction or back pressure

- h = Lift [mm]
- d_0 = Flow diameter [mm] of selected safety valve, refer to table article numbers
- h/d_0 = Ratio of lift / flow diameter
- p_{a0} = Back pressure [bar_a]
- p_0 = Set pressure [bar_a]
- p_{a0}/p_0 = Ratio of back pressure / set pressure
- K_{dr} = Coefficient of discharge acc. to DIN EN ISO 4126-1
- α_w = Coefficient of discharge acc. to AD 2000-Merkblatt A2
- K_b = Back pressure correction factor acc. to API 520 topic 3.3

Diagram for evaluation of ratio of lift / flow diameter (h/d_0) in reference to the coefficient of discharge (K_{dr}/α_w)

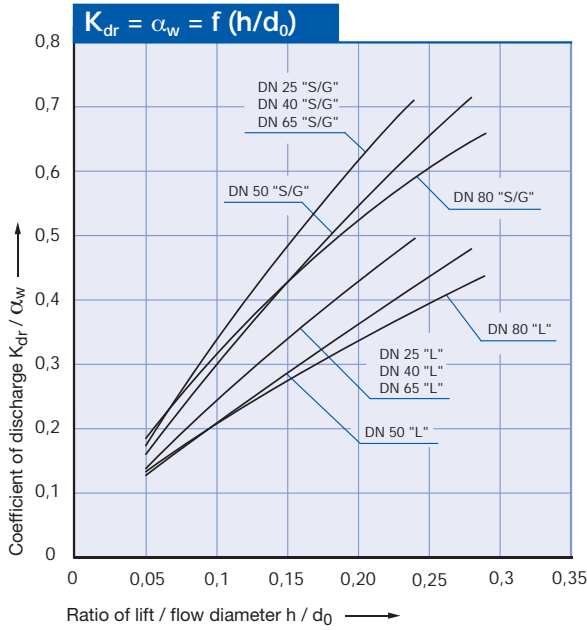
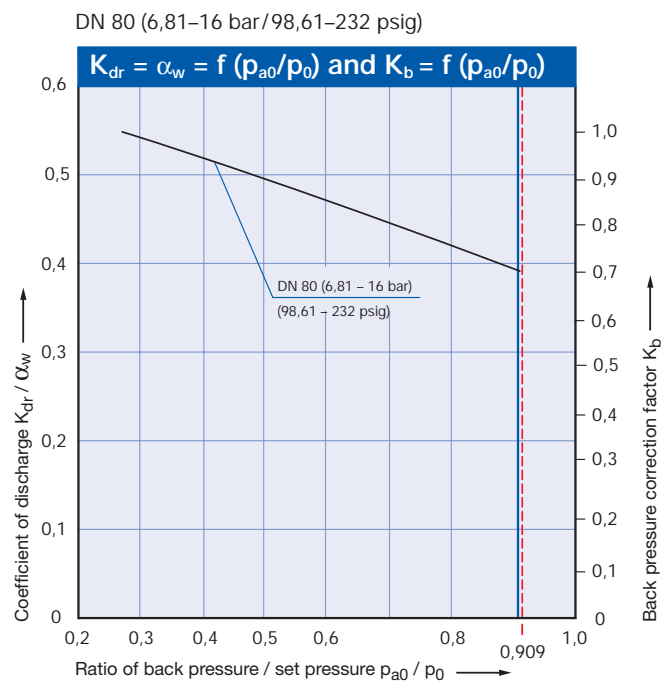
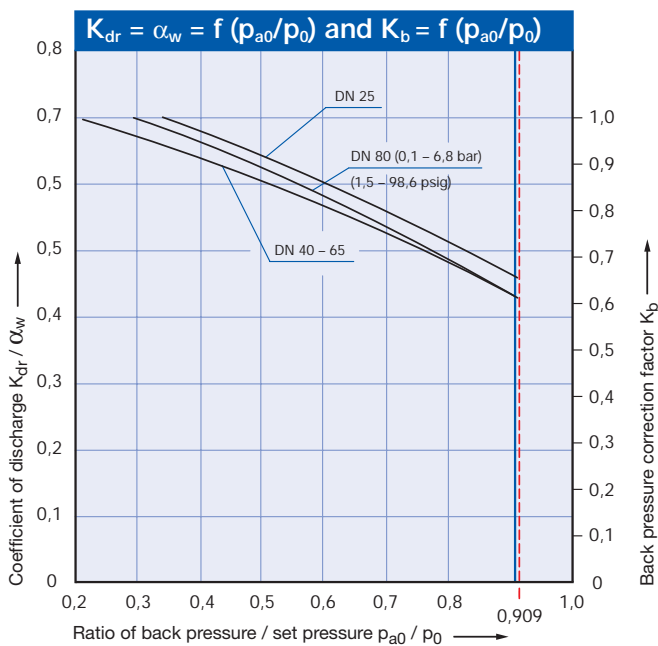

Diagram for evaluation of coefficient of discharge (K_{dr}/α_w) or K_b in reference to the ratio of back pressure / set pressure (p_{a0}/p_0)



How to use please refer to page 00/08

Type 444 ANSI

Type 444 ANSI
Packed lever H4
Closed bonnet
Conventional design

Flanged Safety Relief Valves - spring loaded

Contents Chapter/Page

Materials	
• Conventional design	05/02
How to order	
• Numbering system	05/04
• Article numbers	05/06
Dimensions and weights	
• Metric Units	05/07
• US Units	05/07
Pressure temperature ratings	
• Metric Units	05/08
• US Units	05/08
Flange drillings and facings	05/09
Order information – Spare parts	05/10
Available options	05/11
Approvals	05/12
Capacities	
• Steam [Metric Units + US Units]	05/13
• Air [Metric Units + US Units]	05/14
• Water [Metric Units + US Units]	05/15
Determination of coefficient of discharge K_{dr}/α_w	05/16

Conventional design

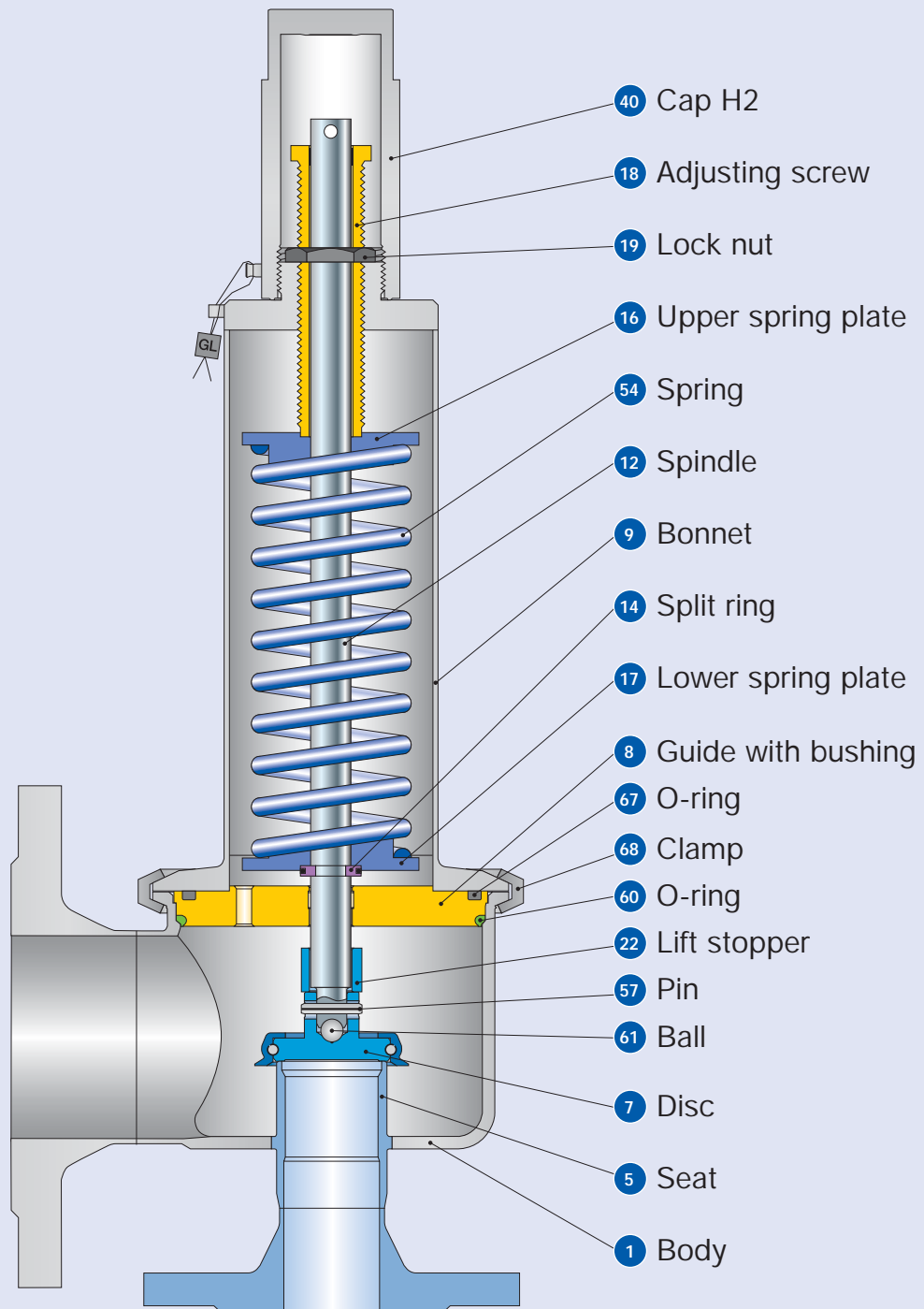

Conventional design

Materials		
Item	Component	Type 4444 ANSI
1	Body	1.4404
		316L
5	Seat	1.4404
		316L
7	Disc	1.4404
		316L
8	Guide	1.4404
		316L
	with bushing	PTFE +15% Glas --
9	Bonnet	1.4404
		316L
12	Spindle	1.4404
		316L
14	Split ring	1.4404
		316L
16 / 17	Spring plate	1.4404
		316L
18	Adjusting screw with bushing	1.4404, PTFE + 15% Glas
		316L, PTFE + 15% Glas
19	Lock nut	1.4404
		316L
22	Lift stopper	1.4404
		316L
40	Cap H2	1.4404
		316L
54	Spring	1.4310
		Stainless steel
57	Pin	1.4310
		302
60	O-ring	EPDM-FDA
		--
61	Ball	1.4401
		316
67	O-ring	EPDM-FDA
		--
68	Clamp	1.4401
		316

Please notice:

- Modifications reserved by LESER.
- LESER can upgrade materials without notice.
- Every part can be replaced by other material acc. to customer specification.

How to order – Numbering system

1

Article Number

1	2	3	4
444	4	893	4

1 Valve Type 444 ANSI
Type 444 – with closed bonnet

2 Material code

Code	Body material
4	1.4404 (316L)

3 Valve code
Identifies valve size and body material, refer to page 05/06.

4

Code	Lifting lever	
2	screwed cap	H2
4	packed lever	H4

4444.8934

Article No.

2

Set Pressure

Please state unit (in gauge)!

Please do not exceed the pressure range defined in the spring charts.

5 barg

Set Pressure

3

Connections

Please refer to page 05/09

H45

Connections

4 Options

Type 444 ANSI	Option code
• O-ring-disc	
CR	"K" J21
EPDM	"D" J22
FKM	"L" J23
FFKM	"C" J20
• Detachable lifting aid	J26
• Adaptor for lift indicator	
– Bonnet	J38
– H4	J39
• Lift indicator	J93
• Test gag	
- cap	H2 J70
- packed lever	H4 J69
• Seat 1.4404/316L stellited	L61

Option code applies only
if not standard

J22

Options

5 Documentation

Please select requested documentation:

Inspections, tests:	Option Code
DIN EN 10204-3.2: TÜV-Nord Certificate for test pressure	M33
LESER Certificate for Global Application	H03
- Inspection certificate 3.1 acc. to DIN EN 10204	
- Declaration of conformity acc. to PED 97/23/EC	
Material test certificate:	
DIN EN 10204-3.1	
Part	Option code
Body	H01
Bonnet	L30
Cap / lever cover	L31
Disc	L23

H01 L30

Documentation

6 Code and Medium

1	2
2	0

1 Code

1. ASME Section VIII
2. CE/VdTUEV
3. ASME Section VIII + CE/VdTUEV

2 Medium

- .1 Gases
- .2 Liquids
- .3 Steam
- .0 Steam / Gases / Liquids
(valid only for CE / VdTUEV)

2.0

Code and Medium

How to order – Article numbers

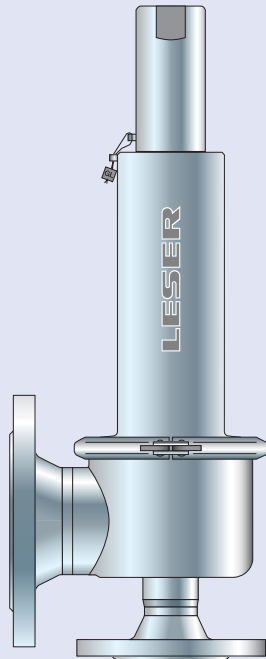

Type 444
Cap H2
Closed bonnet
Conventional design

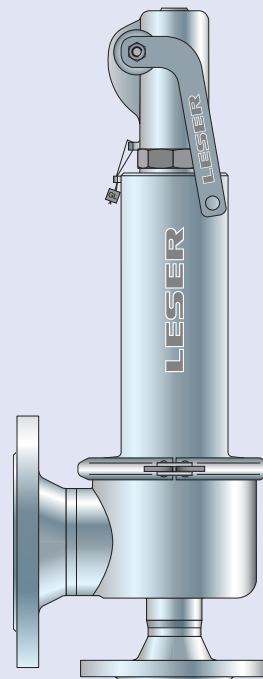

Type 444
Packed lever H4
Closed bonnet
Conventional design

Article numbers

Valve size	1" x 2"	1½" x 3"	2" x 3"	2½" x 4"	3" x 4"	3" x 4"
Actual Orifice diameter d_0 [mm]	23	37	46	60	74	74
Actual Orifice area A_0 [mm ²]	416	1075	1662	2827	4301	4301
Set pressure range S/G/L [bar _g]	see page 05/08				0,61 – 6,8	6,81 – 16
Set pressure range S/G/L [psig]	see page 05/08				1,5 – 98,6	98,61 – 232

Body material: 1.4404 (316L)

Bonnet	H2	Art.-No. 4444.	8902	8922	8932	8942	8952	8962
closed	H4	Art.-No. 4444.	8904	8924	8934	8944	8954	8964

Dimensions and weights

Metric Units

Valve size	1" x 2"	1 1/2" x 3"	2" x 3"	2 1/2" x 4"	3" x 4"	3" x 4"
Actual Orifice diameter d ₀ [mm]	23	37	46	60	74	74
Actual Orifice area A ₀ [mm ²]	416	1075	1662	2827	4301	4301
Set pressure range S/G/L [bar _g]	see page 05/08				0,1 – 6,8	6,81 – 16
Weight [kg]	7	13	14	23	24	24
Center to face [mm]	Inlet a	85	110	110	125	125
	Outlet b	90	128	128	160	160
Height (H4) [mm] Standard H max.	308	519	519	631	631	631

Body material: 1.4404 (316L)

ANSI Flange Class	Inlet	CL150
	Outlet	CL150

US Units

DN _i	1" x 2"	1 1/2" x 3"	2" x 3"	2 1/2" x 4"	3" x 4"	3" x 4"
Actual Orifice diameter d ₀ [inch]	0,91	1,46	1,81	2,36	2,91	2,91
Actual Orifice area A ₀ [inch ²]	0,644	1,667	2,576	4,383	6,666	6,666
Set pressure range S/G/L [psig]	see page 05/08				1,5 – 98,6	98,61 – 232
Weight [lbs]	16	29	31	51	53	53
Center to face [inch]	Inlet a	3 3/8	4 5/16	4 5/16	4 15/16	4 15/16
	Outlet b	3 1/2	5 1/16	5 1/16	6 5/16	6 5/16
Height (H4) [inch] Standard H max.	12 1/8	20 7/16	20 7/16	20 13/16	20 13/16	20 13/16

Body material: 1.4404 (316L)

ANSI Flange Class	Inlet	CL150
	Outlet	CL150

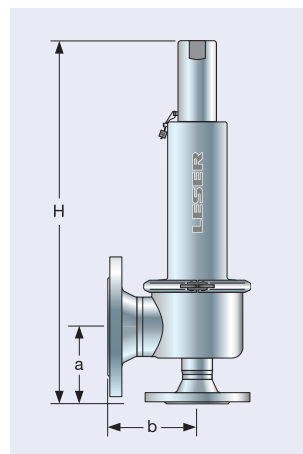

Conventional design

How to use please refer to page 00/08

Pressure temperature ratings

Metric Units		1" x 2"	1½" x 2"	2" x 3"	2½" x 4"	3" x 4"	3" x 4"
Valve size		1" x 2"	1½" x 2"	2" x 3"	2½" x 4"	3" x 4"	3" x 4"
Actual Orifice diameter d ₀ [mm]		23	37	46	60	74	74
Actual Orifice area A ₀ [mm ²]		416	1075	1662	2827	4301	4301
Body material: 1.4404 (316L)							
ANSI Flange Class ¹⁾	Inlet	CL150					
	Outlet	CL150					
Minimum set pressure	p [bar _g] S/G/L	0,1	0,1	0,1	0,1	0,1	6,81
Maximum set pressure	p [bar _g] S/G/L	16	16	16	16	6,8	16
Temperature acc. to DIN EN	min. [°C]	-45					
	max. [°C]	+200					
Temperature acc. to ASME	min. [°C]	-45					
	max. [°C]	+200					

US Units		1" x 2"	1½" x 2"	2" x 3"	2½" x 4"	3" x 4"	3" x 4"
Valve size		1" x 2"	1½" x 2"	2" x 3"	2½" x 4"	3" x 4"	3" x 4"
Actual Orifice diameter d ₀ [inch]		0,91	1,46	1,81	2,36	2,91	2,91
Actual Orifice area A ₀ [inch ²]		0,644	1,667	2,576	4,383	6,666	6,666
Body material: 1.4404 (316L)							
ANSI Flange Class ¹⁾	Inlet	CL150					
	Outlet	CL150					
Minimum set pressure	p [psig] S/G/L	1,5	1,5	1,5	1,5	1,5	98,61
Maximum set pressure	p [psig] S/G/L	232	232	232	232	98,6	232
Temperature acc. to DIN EN	min. [°F]	-49					
	max. [°F]	+392					
Temperature acc. to ASME	min. [°F]	-49					
	max. [°F]	+392					

¹⁾ For flange rating class 150 the pressure temperature ratings according to ASME ANSI B 16.34 apply.

Flange drillings and facings

Flange drillings

DN _i	25	40	50	65	80
DN _o	50	80	80	100	100
Valve size	1" x 2"	1 1/2" x 3"	2" x 3"	2 1/2" x 4"	3" x 4"
Actual Orifice diameter d ₀ [mm]	23	37	46	60	74
Actual Orifice area A ₀ [mm ²]	416	1075	1662	2827	4301

Body material: 1.4404 (316L)

		Body material: 1.4404 (316L)				
		25	40	50	65	80
Inlet	DIN EN 1092	PN 10				
		PN 16				
		PN 25				
		PN 40				
	ASME B16.5	CL150	*	*	*	*
		CL300	-	-	-	-
Outlet	DIN EN 1092	PN 10				
		PN 16				
		PN 25				
		PN 40				
	ASME B16.5	CL150	*	*	*	*
		CL300	-	-	-	-

Flange facings

Indication	Standard	Inlet	Outlet	Remark						
General										
Flange undrilled	-	H38	H39							
Acc. to DIN EN										
Please use Type 444 ANSI										
Acc. to ASME B16.5										
Body material	Inlet	Outlet	Smooth finish ¹⁾		Serrated finish		RTJ-groove			
			Inlet	Outlet	Inlet	Outlet	Inlet		Outlet	
			Option code		Option code		RTJ-Class	Option code	RTJ-Class	Option code
1.4404	all	all	L51	L53	*	*	CL150	H62	CL150	H63

¹⁾ Smooth finish is not defined in the effective standards. For LESER's definition for smooth finish see page 00/07²⁾ Smooth finish is not defined in the effective standards. For LESER's definition for smooth finish see page 00/07.

For signs and symbols refer to page 00/07

Note: Flange drillings and facings meet always the requirements of mentioned flange standards. Flange thickness and outer diameter may vary from flange standard.

Order information – Spare parts

Spare parts								
Valve size		1" x 2"	1½" x 2"	2" x 3"	2½" x 4"	3" x 4"	3" x 4"	
Actual Orifice diameter d ₀ [mm]		23	37	46	60	74	74	
Actual Orifice area A ₀ [mm ²]		416	1075	1662	2827	4301	4301	
Set pressure range S/G/L [bar _g]		see page 05/08				0,1 – 6,8	6,81 – 16	
Set pressure range S/G/L [psig]		see page 05/08				1,5 – 98,6	98,61 – 232	
Disc (Item 7): Metal to metal seat			Material-No. / Art.-No.					
Disc detachable lifting aid	1.4404	225.4149.9000	225.4349.9000	225.4449.9000	225.4549.9000	225.4649.9000	225.4649.9000	
O-ring (Item 60 + 67)			Material-No. / Art.-No.					
Gasket	EPDM "D"	502.0600.3041	502.1130.4041	502.1130.4041	502.1580.5041	502.1580.5041	502.1580.5041	
	FKM "L"	502.0600.3071	502.1130.4071	502.1130.4071	502.1580.5071	502.1580.5071	502.1580.5071	
Ball (Item 61)			Material-No. / Art.-No.					
Ball	ø [mm]	6	9	9	12	12	12	
	1.4401	510.0104.0000	510.0204.0000	510.0204.0000	510.0304.0000	510.0304.0000	510.0304.0000	
Pin (Item 57)			Material-No. / Art.-No.					
Pin	1.4310	480.0505.0000	480.0705.0000	480.0705.0000	480.1005.0000	480.1005.0000	480.1005.0000	

Available Options

For further information refer to "Accessoires and Options", page 99/01

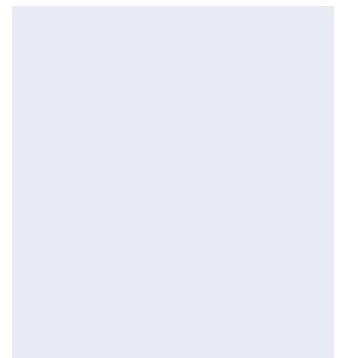
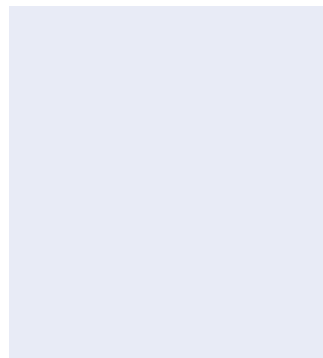
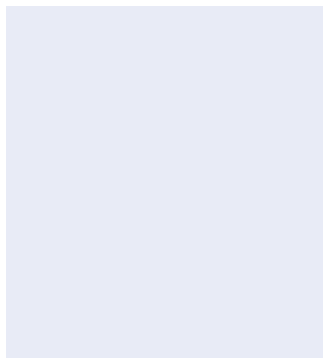
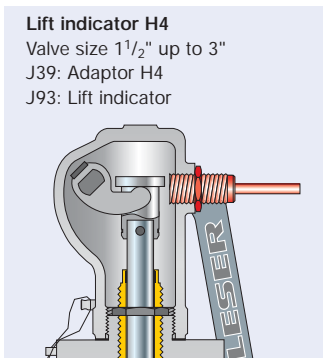
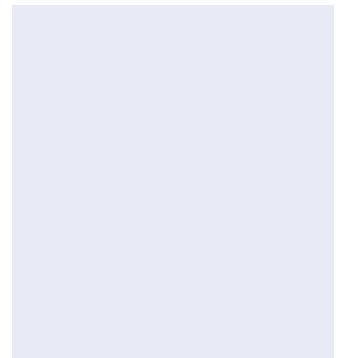
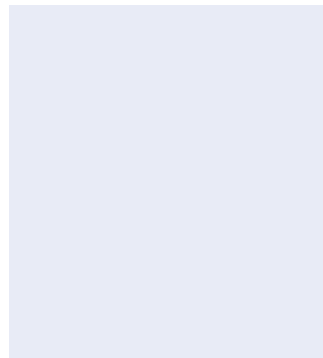
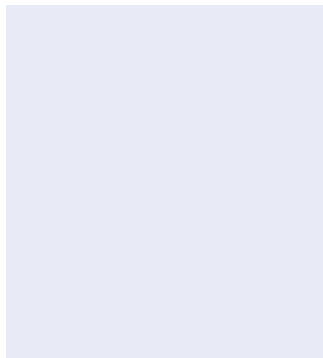
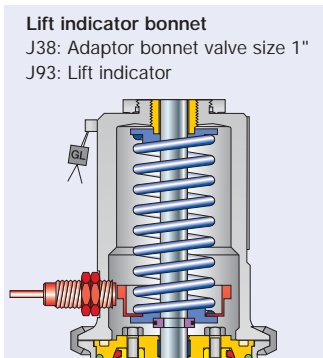
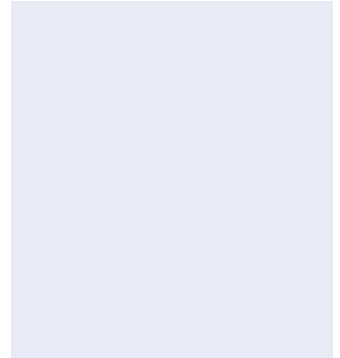
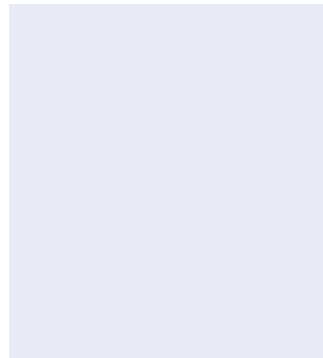
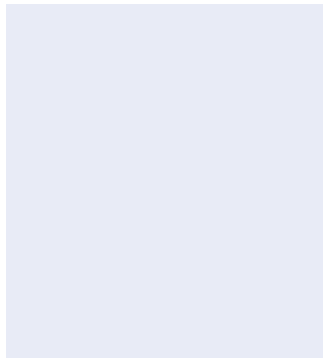
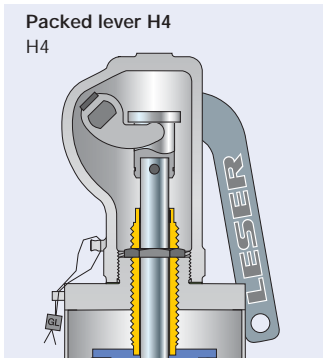
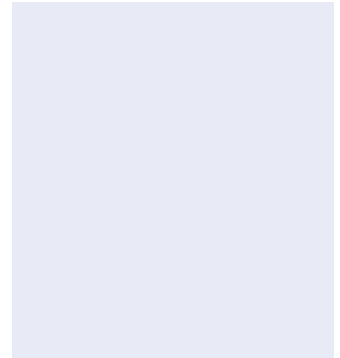
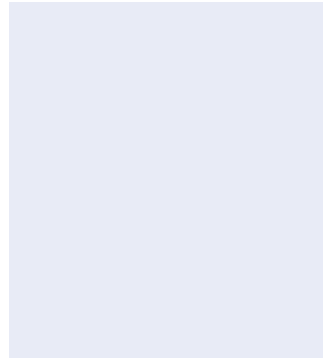
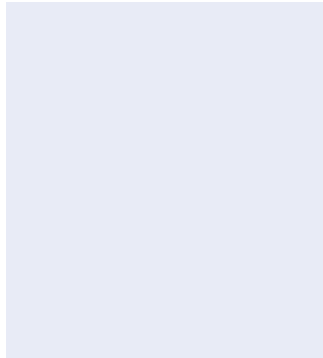
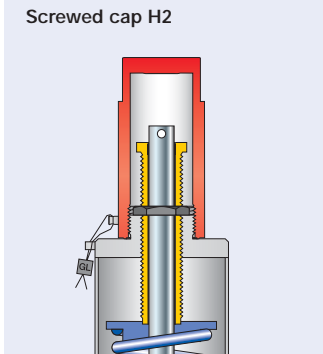

Approvals

Approvals		1" x 2"	1½" x 3"	2" x 3"	2½" x 4"	3" x 4"	3" x 4"
Valve size		1" x 2"	1½" x 3"	2" x 3"	2½" x 4"	3" x 4"	3" x 4"
Actual Orifice diameter d_0 [mm]		23	37	46	60	74	74
Actual Orifice area A_0 [mm ²]		416	1075	1662	2827	4301	4301
Set pressure range S/G/L [bar _g]		see page 05/08				0,1 – 6,8	6,81 – 16
Set pressure range S/G/L [psig]		see page 05/08				1,5 – 98,6	98,61 – 232
Europe		Coefficient of discharge K_{dr}					
DIN EN ISO 4126-1	Approval No.	072020111Z0008/0/08-2					
	S/G	0,7				0,55	
	L	0,48				0,48	
Germany		Coefficient of discharge α_w					
AD 2000-Merkblatt A2	Approval No.	TÜV SV 576					
	S/G	0,7				0,55	
	L	0,48				0,48	
United States		Coefficient of discharge K					
ASME Sec. VIII	Approval No.	M37044				–	
	S/G	0,699				–	
	Approval No.	M37055				M37055	
	L	0,521				0,521	
Canada		Coefficient of discharge K					
Canada: CRN	Approval No.	OG1182.9C					
	S/G	0,699				–	
	L	0,521				0,521	
China		Coefficient of discharge α_w					
CSBQTS							
	S/G	0,7				0,55	
	L	0,48				0,48	
Russia		Coefficient of discharge α_w					
GGTN/GOSGOTECHNADZOR		PPC 00-18458					
GOST R	S/G	0,7				0,55	
	L	0,48				0,48	
Classification societies							
		on request					

Capacities – Steam

Capacities for saturated steam according to AD 2000-Merkblatt A2, based on set pressure plus 10 % overpressure.
Capacities at 1 bar (14,5 psig) and below are based on 0,1 bar (1,45 psig) overpressure.

Metric Units		AD 2000-Merkblatt A2 [kg/h]					
Valve size	1" x 2"	1½" x 3"	2" x 3"	2½" x 4"	3" x 4" ⁽¹⁾	3" x 4" ⁽²⁾	
Act. Orifice dia. d ₀ [mm]	23	37	46	60	74	74	
Act. Orifice area A ₀ [mm ²]	416	1075	1662	2827	4301	4301	
LEO _{S/G} ^{*)} [inch ²]	0,462	1,195	1,847	3,142	4,779	4,779	
Set pressure S/G [bar _g]					0,1–6,8	6,81–16	
Set pressure [bar]	Capacities [kg/h]						
0,1	112	274	405	720	1093		
0,2	144	353	524	927	1417		
0,5	223	546	822	1434	2221		
1	324	790	1209	2086	3262		
2	529	1285	2002	3413	5377		
3	699	1761	2770	4695	7237		
4	872	2256	3487	5932	9023		
5	1043	2700	4174	7101	10801		
6	1215	3143	4858	8266	12573		
7	1382	3575	5526	9402		11237	
8	1552	4015	6206	10559		12619	
9	1721	4455	6885	11714		14000	
10	1891	4894	7564	12868		15380	
12	2230	5772	8922	15179		18141	
14	2562	6631	10249	17437		20840	
16	2901	7507	11603	19740		23593	

Capacities for saturated steam according to ASME Section VIII (UV), based on set pressure plus 10% overpressure.
Capacities at 2,07 bar (30 psig) and below are based on 0,207 bar (3 psig) overpressure.

US Units		ASME Section VIII [lb/h]					
Valve size	1" x 2"	1½" x 3"	2" x 3"	2½" x 4"	3" x 4" ⁽¹⁾	3" x 4" ⁽²⁾	
Act. Orifice dia. d ₀ [inch]	0,91	1,46	1,81	2,36	2,91	2,91	
Act. Orifice area A ₀ [inch ²]	0,644	1,667	2,576	4,383	6,666	6,666	
LEO _{S/G} ^{*)} [inch ²]	0,462	1,195	1,847	3,142	4,779	4,779	
Set pressure S/G [psig]					1,5–98,6	98,61–232	
Set pressure [psig]	Capacities [lb/h]						
15	758	1962	3032	5159	7847		
20	874	2262	3496	5948	9047		
30	1106	2862	4423	7525	11447		
40	1361	3522	5443	9261	14087		
50	1616	4182	6463	10996	16726		
60	1871	4842	7483	12732	19366		
70	2126	5501	8503	14467	22006		
80	2381	6161	9523	16202	24646		
90	2636	6821	10543	17938	27285		
100	2891	7481	11563	19673	29925		
120	3401	8801	13604	23144		35205	
140	3911	10121	15644	26615		40484	
160	4421	11441	17684	30086		45764	
180	4931	12761	19724	33557		51043	
200	5441	14081	21764	37027		56323	
220	5951	15401	23804	40498		61602	
230	6206	16060	24824	42234		64242	

^{*)} LEO_{S/G} = LESER Effective Orifice steam/gas please refer to page 00/11
How to use capacity-sheets refer to page 00/09

Capacities – Air

Capacities for air according to AD 2000-Merkblatt A2, based on set pressure plus 10 % overpressure at 0 °C and 1013 mbar. Capacities at 1 bar (14,5 psig) and below are based on 0,1 bar (1,45 psig) overpressure.

Capacities for air according to ASME Section VIII (UV), based on set pressure plus 10 % overpressure at 16 °C (60 °F). Capacities at 2,07 bar (30 psig) and below are based on 0,207 bar (3 psig) overpressure.

Metric Units		AD 2000-Merkblatt A2 [m _n ³ /h]					
Valve size		1" x 2"	1½" x 3"	2" x 3"	2½" x 4"	3" x 4" ⁽¹⁾	3" x 4" ⁽²⁾
Act. Orifice dia. d ₀ [mm]		23	37	46	60	74	74
Act. Orifice area A ₀ [mm ²]		416	1075	662	2827	4301	4301
LEO _{S/G} ³⁾ [inch ²]		0,462	1,195	1,847	3,142	4,779	–
Set pressure S/G [bar _g]						0,1–6,8	6,81–16
Set pressure [bar]	Capacities [m _n ³ /h]						
0,1	129	316	466	829	1257		
0,2	167	409	607	1073	1640		
0,5	262	640	964	1683	2607		
1	386	941	1440	2484	3884		
2	639	1551	2416	4119	6489		
3	853	2150	3382	5732	8835		
4	1071	2772	4284	7289	11088		
5	1289	3335	5155	8771	13341		
6	1506	3899	6026	10252	15594		
7	1724	4462	6897	11733		14023	
8	1942	5025	7767	13214		15793	
9	2159	5588	8638	14696		17564	
10	2377	6152	9509	16177		19334	
12	2812	7278	11250	19140		22875	
14	3248	8405	12991	22102		26416	
16	3683	9532	14733	25065		29956	

US Units		ASME Section VIII [S.C.F.M.]					
Valve size		1" x 2"	1½" x 3"	2" x 3"	2½" x 4"	3" x 4" ⁽¹⁾	3" x 4" ⁽²⁾
Act. Orifice dia. d ₀ [inch]		0,91	1,46	1,81	2,36	2,91	2,91
Act. Orifice area A ₀ [inch ²]		0,644	1,667	2,576	4,383	6,666	6,666
LEO _{S/G} ³⁾ [inch ²]		0,462	1,195	1,847	3,142	4,779	4,779
Set pressure S/G [psig]						1,5–98,6	98,61–232
Set pressure [psig]	Capacities [S.C.F.M.]						
15	269	697	1077	1832	2786		
20	310	803	1241	2112	3212		
30	393	1016	1571	2672	4064		
40	483	1250	1933	3288	5002		
50	574	1485	2295	3904	5939		
60	664	1719	2657	4521	6876		
70	755	1953	3019	5137	7814		
80	845	2188	3381	5753	8751		
90	936	2422	3744	6369	9688		
100	1026	2656	4106	6985	10625		
120	1208	3125	4830	8218		12500	
140	1389	3594	5555	9450		14375	
160	1570	4062	6279	10682		16249	
180	1751	4531	7003	11915		18124	
200	1932	5000	7728	13147		19998	
220	2113	5468	8452	14380		21873	
230	2204	5703	8814	14996		22810	

³⁾ LEO_{S/G} = LESER Effective Orifice steam/gas please refer to page 00/11
How to use capacity-sheets refer to page 00/09

Capacities – Water

Capacities for water according to AD 2000-Merkblatt A2, based on set pressure plus 10 % overpressure at 20 °C (68 °F). Capacities at 1 bar (14,5 psig) and below are based on 0,1 bar (1,45 psig) overpressure.

Metric Units		AD 2000-Merkblatt A2 [10 ³ kg/h]					
Valve size		1" x 2"	1½" x 3"	2" x 3"	2½" x 4"	3" x 4" ⁽¹⁾	3" x 4" ⁽²⁾
Act. Orifice dia. d ₀ [mm]		23	37	46	60	74	74
Act. Orifice area A ₀ [mm ²]		416	1075	1662	2827	4301	4301
LEO _L ⁽³⁾ [inch ²]		0,516	1,336	2,065	3,513	5,343	5,343
Set pressure L [bar _g]						0,1–6,8	6,81–16
Set pressure [bar]		Capacities [10 ³ kg/h]					
0,1		4,54	11,8	18,2	30,9	47,0	
0,2		5,56	14,4	22,2	37,8	57,6	
0,5		7,87	20,4	31,5	53,5	81,4	
1		10,6	27,6	42,6	72,5	110	
2		15,1	39	60,2	102	156	
3		18,4	47,7	73,8	126	191	
4		21,3	55,1	85,2	145	220	
5		23,8	61,6	95,3	162	246	
6		26,1	67,5	104	178	270	
7		28,2	72,9	113	192		292
8		30,1	77,9	120	205		312
9		31,9	82,7	128	217		331
10		33,7	87,2	135	229		349
12		36,9	95,5	148	251		382
14		39,8	103	159	271		412
16		42,6	110	170	290		441

Capacities for water according to ASME Section VIII (UV), based on set pressure plus 10 % overpressure at 21 °C (70 °F). Capacities at 2,07 bar (30 psig) and below are based on 0,207 bar (3 psig) overpressure.

US Units		ASME Section VIII [US-G.P.M.]					
Valve size		1" x 2"	1½" x 3"	2" x 3"	2½" x 4"	3" x 4" ⁽¹⁾	3" x 4" ⁽²⁾
Act. Orifice dia. d ₀ [inch]		0,91	1,46	1,81	2,36	2,91	2,91
Act. Orifice area A ₀ [inch ²]		0,644	1,667	2,576	4,383	6,666	6,666
LEO _L ⁽³⁾ [inch ²]		0,516	1,336	2,065	3,513	5,343	5,343
Set pressure L [psig]						1,5–98,6	98,61–232
Set pressure [psig]		Capacities [US-G.P.M.]					
15		54,1	140	216	368	560	
20		61,1	158	245	416	633	
30		73,2	190	293	498	758	
40		84,6	219	338	576	875	
50		94,6	245	378	643	979	
60		104	268	414	705	1072	
70		112	290	447	761	1158	
80		120	310	478	814	1238	
90		127	328	507	863	1313	
100		134	346	535	910	1384	
120		146	379	586	997		1516
140		158	409	633	1077		1638
160		169	438	677	1151		1751
180		179	464	718	1221		1857
200		189	489	756	1287		1958
220		198	513	793	1350		2053
230		203	525	811	1380		2099

³⁾ LEO_L = LESER Effective Orifice liquids please refer to page 00/12
How to use capacity-sheets refer to page 00/09

Determination of coefficient of discharge in case of lift restriction or back pressure

- h = Lift [mm]
- d_0 = Flow diameter [mm] of selected safety valve, refer to table article numbers
- h/d_0 = Ratio of lift / flow diameter
- p_{a0} = Back pressure [bar_a]
- p_0 = Set pressure [bar_a]
- p_{a0}/p_0 = Ratio of back pressure / set pressure
- K_{dr} = Coefficient of discharge acc. to DIN EN ISO 4126-1
- α_w = Coefficient of discharge acc. to AD 2000-Merkblatt A2
- K_b = Back pressure correction factor acc. to API 520 topic 3.3

Diagram for evaluation of ratio of lift / flow diameter (h/d_0) in reference to the coefficient of discharge (K_{dr}/α_w)

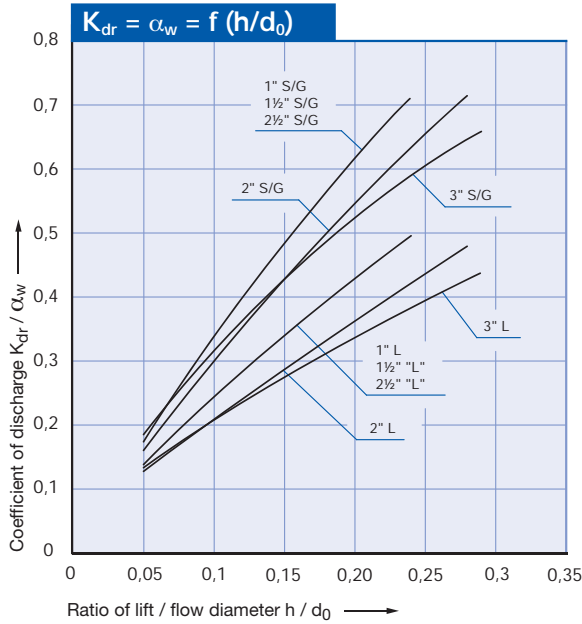
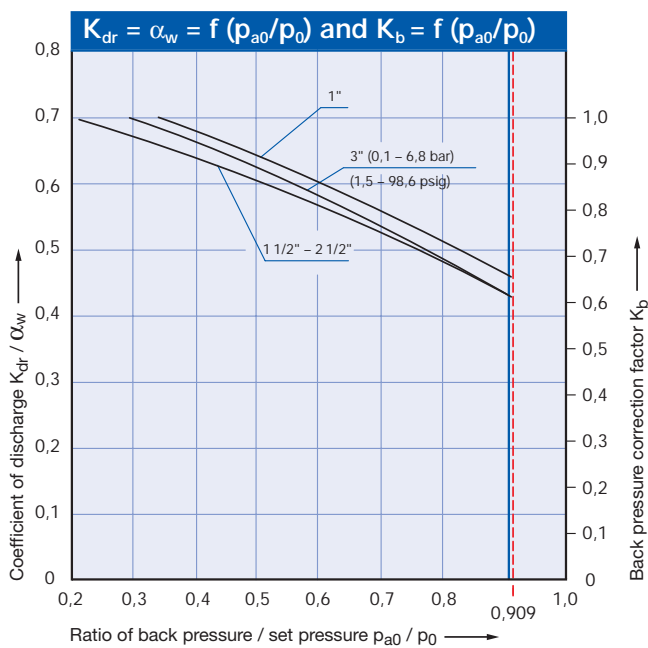
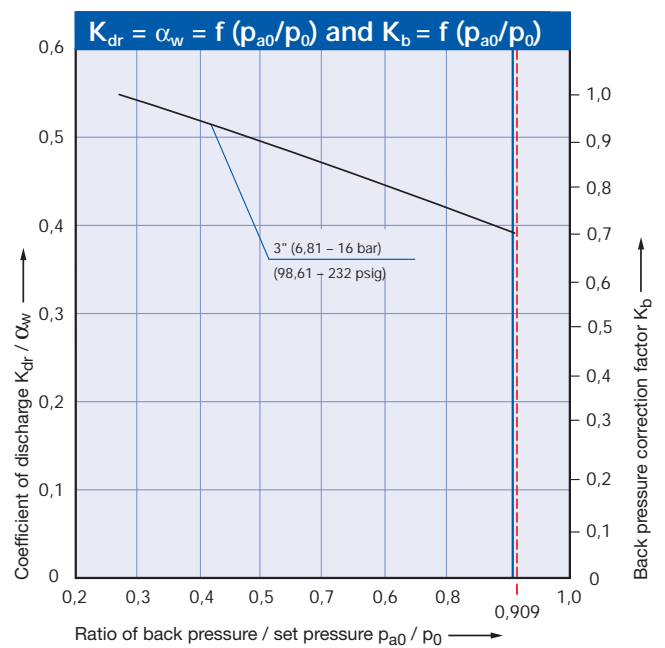

Diagram for evaluation of coefficient of discharge (K_{dr}/α_w) or K_b in reference to the ratio of back pressure / set pressure (p_{a0}/p_0)



3" (6,81–16 bar/98,61–232 psig)



How to use please refer to page 00/08

Accessories and Options



Contents

Chapter/Page

Overview	99/02
Caps and Levers	99/04
Caps and Levers bolted	99/06
Metal seat	99/08
Soft seal disc	99/10
Soft seal	99/12
Balanced bellows	99/14
High temperature equipment	99/16
Elastomer bellows	99/17
Disc	99/18
Heating jacket	99/20
O-ring damper	99/22
Lift indicator	99/24
Lift restriction	99/25
First in safety	
Informations tools	

Overview

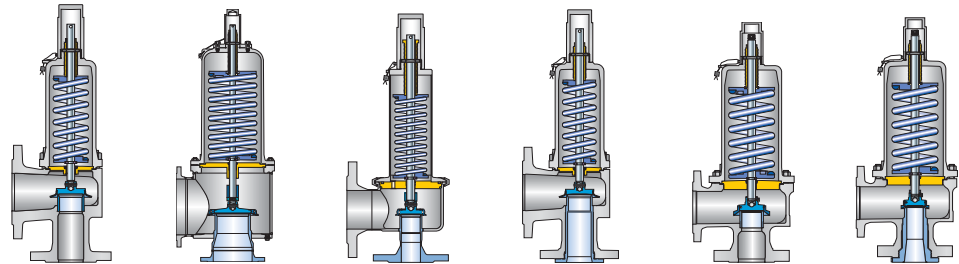

Options								
Type		441, 442 DIN 441, 442 ANSI	441, 442 XXL	444 DIN 444 ANSI	441 Full nozzle DIN 441 Full nozzle ANSI 442 Full nozzle DIN 442 Full nozzle ANSI	455/456	457/458	
Disc (Item 7)								
	Disc with detachable lifting aid	✓	*	*	✓	*	*	
	Bull race disc	✓	✓	✓	✓	*	*	
Type of sealing (Item 5 and 7)								
Metal seat	Metal-to-metal	✓	✓	✓	✓	✓	✓	
	Metal-to-metal stellite	✓	✓	✓	✓	✓	✓	
Soft seat	O-ring	✓	on request	-	✓	✓	✓	
	Sealing plate	✓	-	-	✓	-	-	
Bellows (Item 15, item70)								
	Stainless steel	✓	✓	select 4414	✓	✓	✓	
	low pressure	✓	-	select 4414	✓	on request	on request	
	Hastelloy® or special materials	✓	✓	select 4414	✓	✓	✓	
	High temperature equipment	-	-	-	-	✓	✓	
	Elastomer	✓	-	select 4414	✓	-	-	
Caps and levers (Item 40)								
	H2	✓	✓	✓	✓	✓	✓	
	H3	✓	-	-	✓	✓	✓	
	H4	✓	✓	✓	✓	✓	✓	
Bolted	H1	-	✓	-	-	-	-	
	H6	-	✓	-	-	-	-	

Item – Numbers of the components please refer to standard master bill of materials and sectional drawing.

Overview

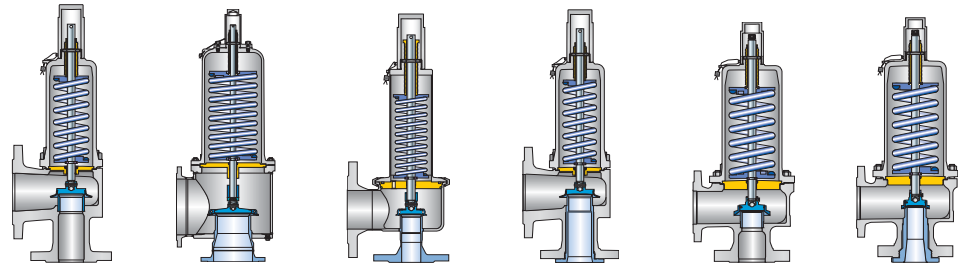

Options		Type	441, 442 DIN 441, 442 ANSI	441, 442 XXL	444 DIN 444 ANSI	441 Full nozzle DIN 441 Full nozzle ANSI 442 Full nozzle DIN 442 Full nozzle ANSI	455/456	457/458
Test gag								
	H2 (H1)	✓	✓	✓	✓	✓	✓	✓
	H4 (H6)	✓	✓	✓	✓	✓	✓	✓
Bonnet (Item 9)								
	closed	✓	✓	✓	✓	✓	✓	✓
	open	✓	✓	-	✓	✓	✓	✓
Heating jacket								
		✓	-	-	✓	✓	✓	✓
Lift indicator								
	Lifting device H2 (H1), H4 (H6)	✓	✓	✓	✓	✓	✓	✓
	bonnet	-	-	✓	-	-	-	-
Lift stopper								
	bush	✓	✓	✓	✓	✓	✓	✓
	gag	✓	✓	✓	✓	✓	✓	✓
Drain hole								
		✓	✓	-	✓	✓	✓	✓
O-ring damper (Item 40)								
	H2	✓	-	✓	✓	-	-	-
	H4	✓	-	✓	✓	-	-	-
Bursting disc KUB								
		✓	-	✓	✓	✓	✓	✓
refer to catalog "Best Availability"								

Caps and levers – Subassembly item 40

Cap H2

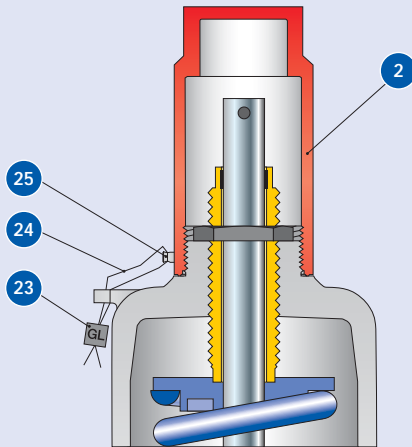

Packed lever H4

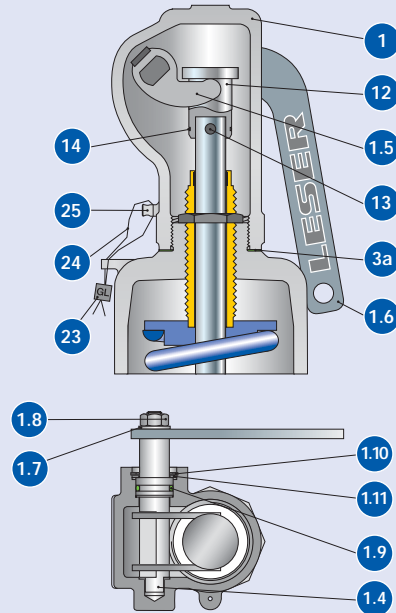

Plain lever H3

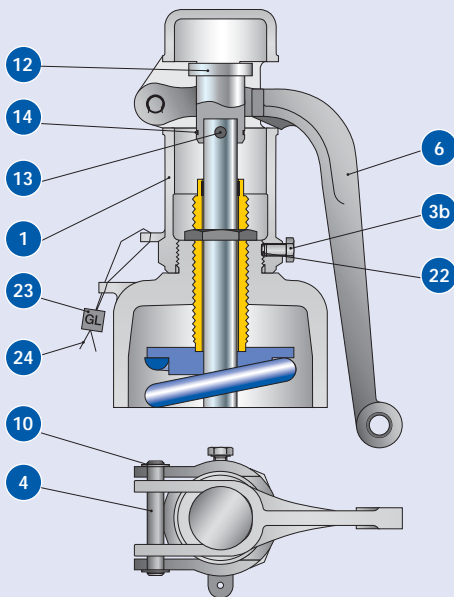

Test gag

Cap H2: J70
Packed lever H4: J69

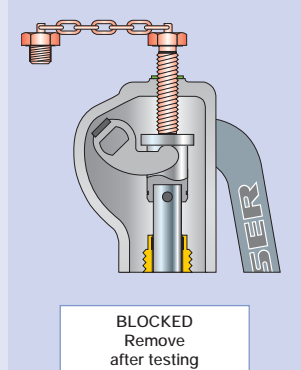
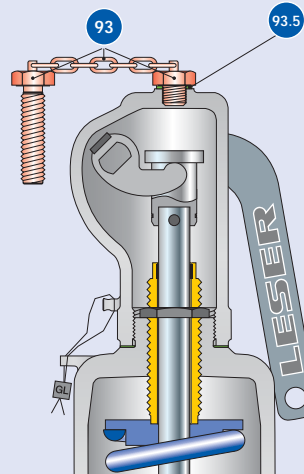

Test gag

The test gag blockades the spindle and keeps the safety valve tight while the system pressure exceeds the set pressure.

The test gag is used for:

- to perform pressure tests in a system without dismantling of the safety valve
- the individual adjustment of safety valves installed in the same system

After testing the test gag must be removed because otherwise the safety valve cannot protect the system against unallowable overpressure!

Caps and levers – Subassembly item 40

Materials		Steel			Stainless steel	
Item	Component	Cap H2	Plain lever H3	Packed lever H4	Cap H2	Packed lever H4
1	Lever cover	-	0.7040	0.7040	-	1.4408
		-	Gr. 60-40-18	Gr. 60-40-18	-	CF8M
2	Cap	1.0718	-	-	1.4404	-
		Steel	-	-	316L	-
3a	Spacer	-	-	1.4571	-	1.4571
		-	-	316Ti	-	316Ti
3b	Hex screw	-	1.4401	-	-	-
		-	B8M	-	-	-
4/1.4	Shaft / bolt	-	1.4021	1.0718	-	1.4404
		-	420	Steel	-	316L
1.5	Lifting fork	-	-	1.0531	-	1.4571
		-	-	Steel	-	316Ti
6/1.6	Lever	-	0.7040	1.0036	-	1.4301
		-	Gr. 60-40-18	Steel	-	304
1.7	Washer	-	-	1.4401	-	1.4301
		-	-	316	-	304
1.8	Nut	-	-	A2/Poly	-	1.4401
		-	-	2H	-	8M
1.9	O-ring	-	-	Viton®	-	-
		-	-	-"-	-	-
1.9	Bushing	-	-	-	-	Graphite
		-	-	-	-	-"-
10/1.10	Retaining clip	-	Carbon steel	Carbon steel	-	-
		-	-"-	-"-	-	-
1.10	Nut	-	-	-	-	1.4104
		-	-	-	-	Chrome steel
1.10	Packing gland	-	-	-	-	1.4404
		-	-	-	-	316L
1.11	Support ring	-	-	Carbon steel	-	-
		-	-	-"-	-	-
12	Spindle cap	-	1.0718	1.0718	-	1.4404
		-	Carbon steel	Carbon steel	-	316L
13	Pin	-	Steel	Steel	-	1.4401
		-	-"-	-"-	-	8M
14	Retaining clip	-	1.4571	1.4571	-	1.4571
		-	316Ti	316Ti	-	316Ti
22	Plug	-	Plastic	-	-	-
		-	-"-	-	-	-
23	Seal	Plastic	Plastic	Plastic	Plastic	Plastic
		-"-	-"-	-"-	-"-	-"-
24	Seal wire	1.4541	1.4541	1.4541	1.4541	1.4541
		321	321	321	321	321
25	Sealing nose	1.4435	-	-	1.4435	1.4435
		316L	-	-	316L	316L
93	Test gag	1.4401	-	1.4401	1.4401	1.4401
		B8M	-	B8M	B8M	B8M
93.5	Washer	Fiber	-	Fiber	Fiber	Fiber
		-"-	-	-"-	-"-	-"-

Please notice:

- Modifications reserved by LESER.
- LESER can upgrade materials without notice.
- Every part can be replaced by other material acc. to customer specification.

Caps and levers bolted – Subassembly item 40

Bolted Cap H1

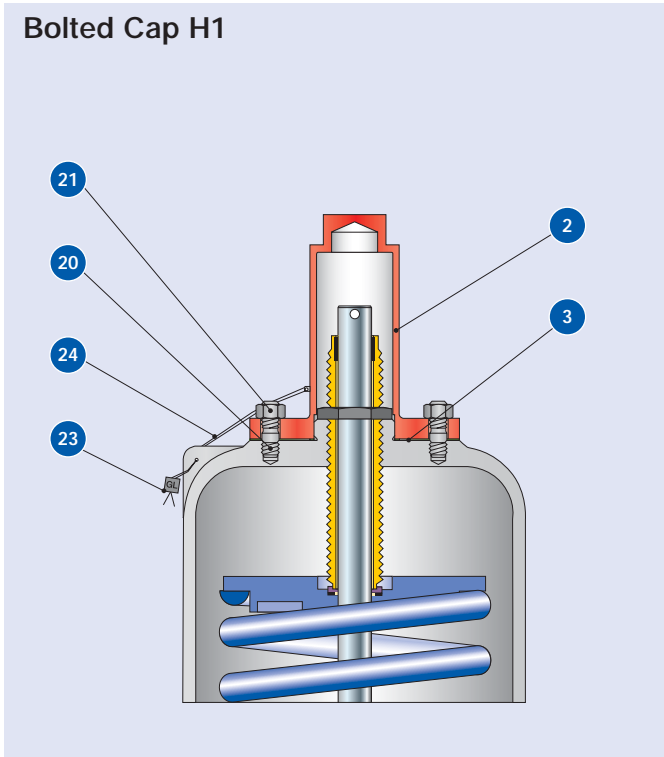

Bolted lifting device H6

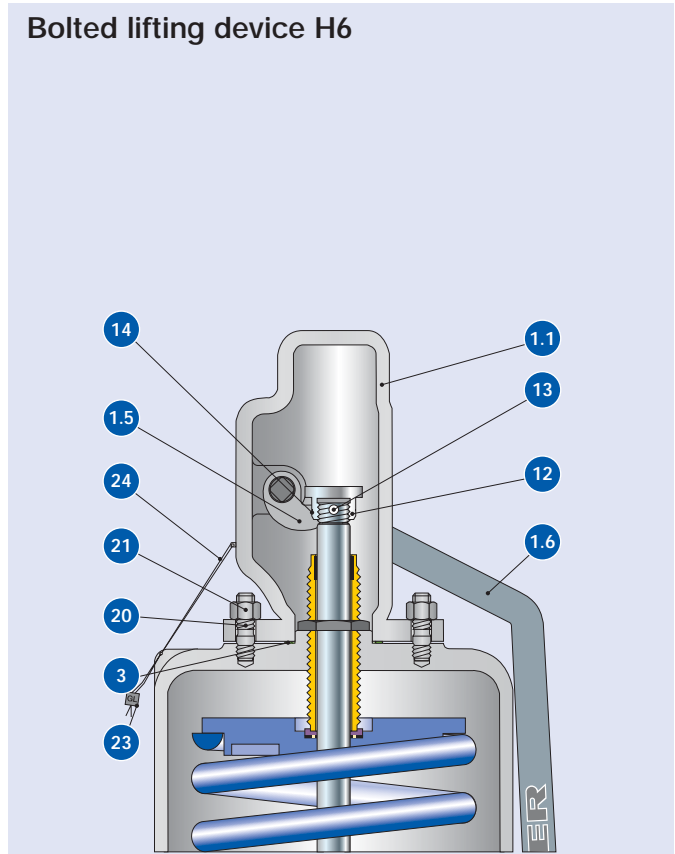

Test gag

Bolted cap H1: J70
Bolted lifting device H6: J69

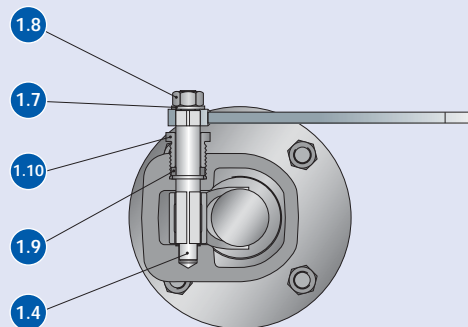
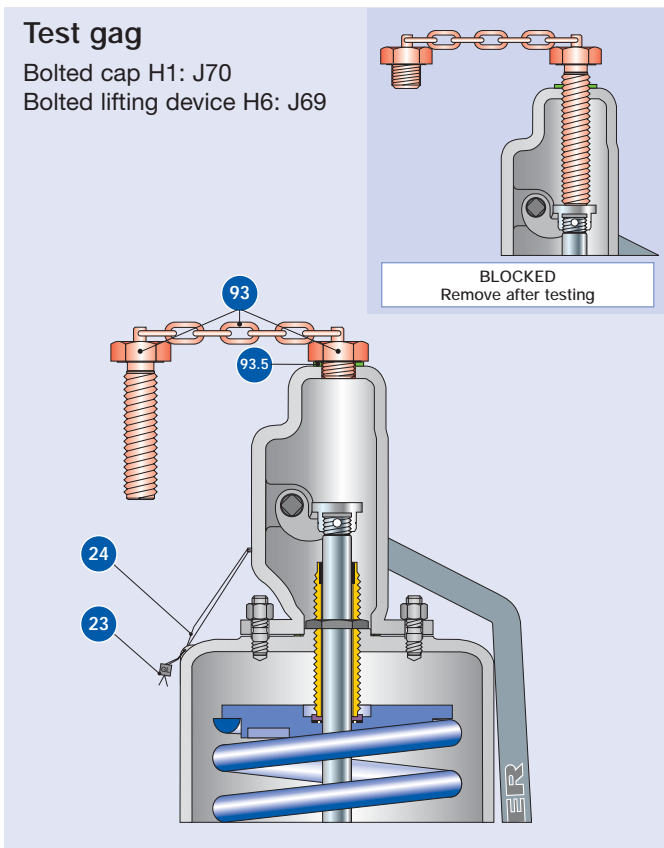
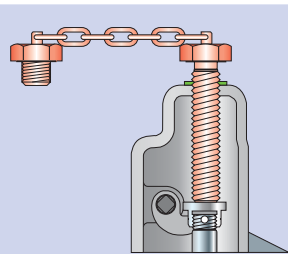

Caps and levers bolted – Subassembly item 40

Materials		Steel		Stainless steel	
Item	Component	Bolted cap H1	Bolted lifting device H6	Bolted cap H1	Bolted lifting device H6
1.1	Lever cover	–	0.7040	–	1.4408
		–	Gr. 60-40-18	–	CF8M
1.4	Shaft/bolt	–	1.0718	–	1.4404
		–	Steel	–	316L
1.5	Lifting fork	–	1.4408	–	1.4408
		–	CF8M	–	CF8M
1.6	Lever	–	1.0036	–	1.4571
		–	Carbon steel	–	316Ti
1.7	Washer	–	Steel	–	1.4401
		–	–	–	316
1.8	Nut	–	1.0501	–	1.4401
		–	2H	–	8M
1.9	Bushing	–	Graphite	–	Graphite
		–	–	–	–
1.10	Packing gland	–	1.4104	–	1.4404
		–	Chrome steel	–	316L
2	Cap	0.7040	–	1.4408	–
		Gr. 60-40-18	–	CF8M	–
3	Gasket	Graphite / 1.4401	Graphite / 1.4401	1.4571	1.4571
		Graphite / 316L	Graphite / 316L	316Ti	316Ti
12	Spindle cap	–	1.0718	–	1.4404
		–	Carbon steel	–	316L
13	Pin	–	Steel	–	1.4401
		–	–	–	8M
14	Retaining clip	–	1.4571	–	1.4571
		–	316Ti	–	316Ti
20	Stud	1.1181	1.1181	1.4401	1.4401
		Steel	Steel	B8M	B8M
21	Nut	1.0501	1.0501	1.4401	1.4401
		2H	2H	8M	8M
23	Seal	Plastic	Plastic	Plastic	Plastic
		–	–	–	–
24	Seal wire	1.4541	1.4541	1.4541	1.4541
		321	321	321	321
93	Test gag	1.4401	1.4401	1.4401	1.4401
		B8M	B8M	B8M	B8M
93.5	Washer	Fiber	Fiber	Fiber	Fiber
		–	–	–	–

Please notice:

- Modifications reserved by LESER.
- LESER can upgrade materials without notice.
- Every part can be replaced by other material acc. to customer specification.

Metal seat – Seat/nozzle item 5 and disc subassembly item 7

The LESER metal seats (disc and nozzle) are lapped to optical flatness to ensure a tight seal. LESER safety relief valves are supplied with standard leak tightness according to API 527. Improved tightness is available on request.

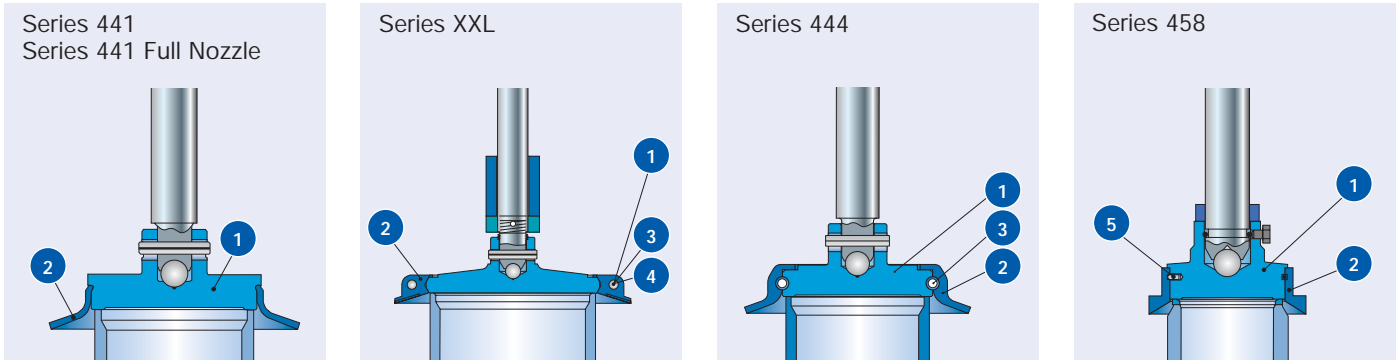

Stellited sealing surfaces

The sealing surfaces of stainless steel disc and nozzle can be stellited by build-up welding. Stellite is a cobalt-chromium based, non-ferrous alloy with increased hardness, corrosion resistance and wear resistance up to high temperatures.

LESER recommends stellited sealing surfaces for High Performance valves (seat and disc 1.4404 / 316L) in the following cases:

- high pressure applications, due to the high stress of the sealing surfaces
- high temperature applications to avoid a permanent deformation of the sealing surfaces, due to the material properties of the seat and disc
- applications with abrasive fluids to increase the wear resistance of the sealing surfaces

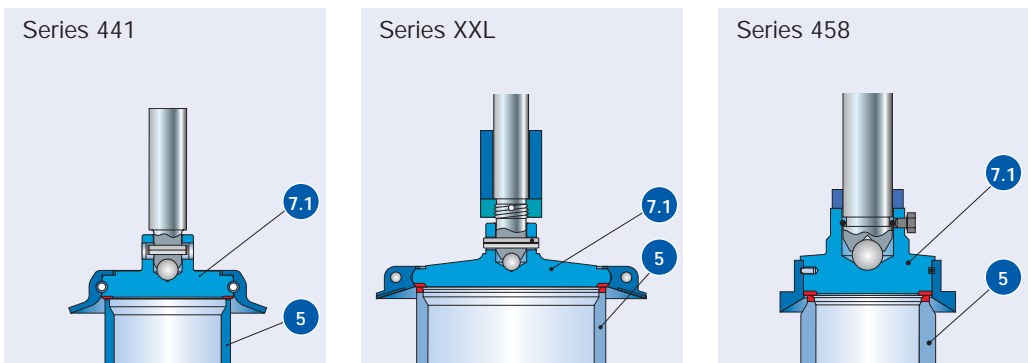

Materials for disc and seat/nozzle see page 99/09.

Hardness metal seat

Material		Hardness of sealing surfaces		
EN	ASME	Values from standards or manufacturers specification		Average value LESER stock
EN 10088-3, 1.4122 hardened	Hardened stainless steel	≥ 40 HRC	LWN 325.01 Harding procedure	42 – 46 HRC
EN 10272, 1.4404	SA 479 316L	≤ 215 HBW	EN 10272 Table 7	16 – 19 HRC ¹⁾
EN 10272, 1.4404 stellited	SA 479 316L stellited	≥ 35 HRC	Manufacturers specification	40 HRC

HBW: BRINELL hardness acc. DIN EN ISO 6506-1 / HRC: ROCKWELL hardness acc. DIN EN ISO 6508-1

¹⁾ Rockwell hardness values below 20 HRC are not allowed according to DIN EN ISO 6508-1. Lower, fictitious values were created for better comparison.

Metal seat – Seat/nozzle item 5 and disc subassembly item 7

Standard and corrosive service

Materials		Disc – Subassembly item 7	
Item	Component	Steel	Stainless steel
Series 441, 441 Full nozzle			
1	Disc	1.4122 hardened Hardened stainless steel	1.4404 316L
2	Lifting aid	1.4404 316L	1.4404 316L
Series XXL			
1	Disc	1.4404, 1.4571 316L, 316Ti	1.4404, 1.4571 316L, 316Ti
2	Lifting aid	1.4581, 1.4571 CF10M, 316Ti	1.4581, 1.4571 CF10M, 316Ti
5	Screw	1.4401 B8M	1.4401 B8M
6	Nut	1.4401 8M	1.4401 8M
7	Washer	1.4401 Stainless steel	1.4401 Stainless steel
Series 444			
1	Disc	– –	1.4404 316L
2	Lifting aid	– –	1.4404 316L
3	Securing ring (DN 25/1" only)	– –	1.4571 316Ti
3	Rollpin	– –	1.4310 Stainless steel
Series 458			
1	Disc	1.4122 hardened Hardened stainless steel	1.4404 316L
2	Lifting aid	1.4404 316L	1.4404 316L
3	Securing ring	1.4571 316Ti	1.4571 316Ti

Materials		Seat / nozzle – Item 5	
Item	Component	Steel	Stainless steel
All Series			
5	Seat / nozzle	refer to respective master bill of materials	

Stellited sealing surfaces

Materials		Seat / nozzle – Item 5, disc – Item 7	
Item	Component	Option code	
Series 441, XXL, 458			
7.1	Disc	J25	1.4404 stellited, 1.4571 stellited 316L stellited, 316Ti stellited
5	Seat / nozzle	L61 / L62	1.4404 stellited, 1.0305 stellited, 1.4571 stellited 316L stellited, carbon steel stellited, 316Ti stellited

Soft seal disc – Subassembly item 7

LESER soft seal solutions allow for superior tightness.

Features and Benefits

- two different designs with o-ring or sealing plate (Series 441 and 441 Full Nozzle only) for a wide variety application
- large selection of soft seal materials to best adapt to the application
- increased service life of sealing surfaces compared to a metal to metal seat
- simple replacement of the soft seal reduces maintenance costs
- standard ARP O-ring sizes for easy worldwide procurement
- one standard durometer per O-ring material for all set pressures to reduce stocking expenses

Design of soft seal

O-ring disc

Series 441
Series 441 Full Nozzle

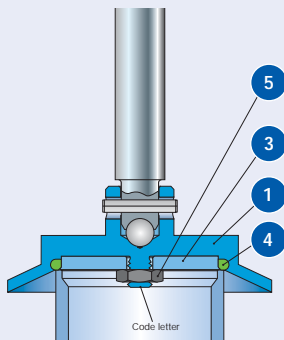

Series XXL

Please contact LESER
for special design
sales@leser.com

Series 458

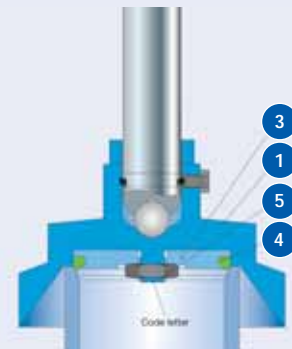

Design of soft seal

Disc with sealing plate

Series 441
Series 441 Full Nozzle

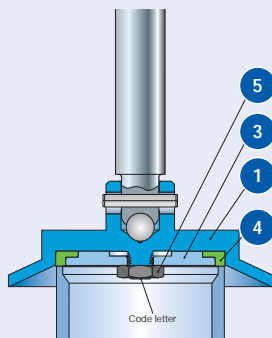

For temperature limits, medium resistance and option codes please refer to the soft seal selection table, page 99/12.
Materials for soft seal discs see page 99/11.

Soft seal disc – Subassembly item 7

Materials		O-ring disc	
Item	Component	Steel	Stainless steel
Series 441, 441 Full nozzle, 458			
1	Disc with lifting aid	1.4404 316L	1.4404 316L
3	Retainer	1.4404 316L	1.4404 316L
4	O-ring	See soft seal selection table page 99/12	See soft seal selection table page 99/12
5	Nut	1.4401 8M	1.4401 8M

Materials		Disc with sealing plate	
Item	Component	Steel	Stainless steel
Series 441, 441 Full nozzle			
1	Disc with lifting aid	1.4404 316L	1.4404 316L
3	Retainer	1.4404 316L	1.4404 316L
4	Sealing plate	See soft seal selection table page 99/12	See soft seal selection table page 99/12
5	Nut	1.4401 8M	1.4401 8M

Soft seal

Soft seal selection								
Abbreviation ASTM 1418	Trade name (Designation)	Code- letter ¹⁾	Option Code	T _{min}		T _{max}		Application ²⁾
				[°C]	[°F]	[°C]	[°F]	
O-ring								
CR	Neoprene®	K	J21	-40	-40	100	212	Parafin oil, silicone oil and grease, water and waterbased solvents, refrigerants, ozone
NBR	Buna-N® (Nitrile-Butadiene)	N	J30	-25	-13	100	212	Hydraulic oil, vegetable and animal grease and oil
EPDM	Buna-EP® (Ethylene-Propylene-Diene)	D	J22	-45	-49	150	302	Hot water and superheated steam up to 150 °C, 302 °F, some organic and inorganic acids, silicone oil and grease, FDA compliant
FKM	Viton® (Fluorocarbon)	L	J23	20	-4	180	356	High temperature service (no superheated steam), mineral oil and grease, silicone oil and grease, vegetable and animal grease and oil, ozone, FDA compliant compound available on request
FFKM	Kalrez® (Perfluoro)	C	J20	0	32	250	482	Nearly all chemicals, standard compound is Kalrez® 6375 with steam resistance, FDA compliant compound available on request
Sealing plate								
SP	VESPEL SP-1® ³⁾ (Polyimide)	T	J49	-270	-454	300	572	High temperature and high pressure applications (no steam), for chemical resistance refer to manufacturers guide
PCTFE	KEL-F® (Polychlorotrifluoroethylene)	G	J48	-270	-454	204	400	Cryogenic and refrigeration applications, flammable media applications, (e.g. gaseous oxygen) up to 50 bar, 725 psig at 60 °C, 140 °F
PTFE	Teflon® (Polytetrafluoroethylene)	A	J44	-184	-300	150	302	Nearly all chemicals
Other than listed		X	For other materials please contact your local representative or sales@leser.com					

¹⁾ The code letters will be stamped on the disc (Item 1).

²⁾ Pressure and temperature service must be considered in any case.

Chemical resistance information is supplied by the O-ring manufacturer. LESER can not take any warranty.

³⁾ For valve size DN 25, 1" x 2" only.

Soft seal

Soft seal disc		Set pressure and size limits				DIN Valve size
Material	Pressure range					
	min.		max.			
	[bar]	[psig]	[bar]	[psig]		
Series 441, 441 Full nozzle						
CR NBR EPDM FKM FFKM	0,1	1,5	51	740	DN 20 – 150 1" – 6"	
VESPEL SP-1®	10	150	51	740	DN 25 1"	
Kel-F®	1	15	51	740	DN 25 – 125 1" – 5"	
Teflon®	1	15	10	145	DN 25 – 125 1" – 5"	
Series 458						
CR NBR EPDM FKM FFKM	–	–	–	–	DN 25/1", d ₀ 15	
	4	9	105	225	DN 25/1", d ₀ 20	
	8,6	19	102	225	DN 50/2", d ₀ 30	
	3,5	8	102	225	DN 50/2", d ₀ 40	
	4	9	77	170	DN 80/3", d ₀ 50	
	5	11	77	170	DN 80/3", d ₀ 60	
	4	9	77	170	DN 100/4", d ₀ 50	
	5	11	77	170	DN 100/4", d ₀ 60	
	2,5	6	60	132	DN 100/4", d ₀ 74	
	2,5	6	51	112	DN 100/4", d ₀ 88	
2,5	6	40	88	DN 150/6", d ₀ 110		

Trademarks	Soft seal
Registered trademarks	Company
Buna-N®, Teflon® Viton®, VESPEL SP-1® Neoprene®, Kalrez®	DuPont
Buna EP®	Bayer
Kel-F®	3M

Balanced bellows – Subassembly item 15

LESER is able to provide a balanced bellows design through the use of stainless steel bellows.

Balanced bellows are generally used for two applications:

- to compensate for back pressure
- to seal off the bonnet from the outlet chamber

Compensation for back pressure

The back pressure acts on the reverse side of the disc, creating a force in the closing direction (F_C) of the safety valve. The magnitude of this force depends on the seat area and the level of the back pressure. The balanced bellows constitute an opposite area with the same area like the seat. The back pressure acts on, thereby reducing or eliminating the closing force. This reduction of the force in the closing direction can be viewed as a compensating force acting in the opening direction (F_O).

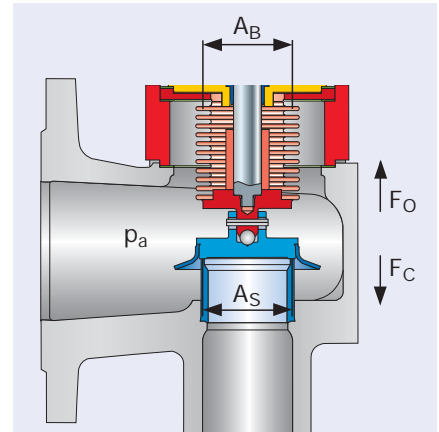

A quantitative representation is shown in the table below:

Actual area	Back pressure	Actual force	Direction of force	Compensation criteria
Seat area = A_S	p_a	$F_C = p_a \times A_S$	closing	$A_S = A_B$
Bellows area = A_B	p_a	$F_O = p_a \times A_B$	opening	$F_C = F_O$

Sealing the bonnet from the outlet chamber

LESER's balanced bellows reliably seal the bonnet from the outlet chamber; protecting the guide, moving parts and the spring from problems associated with the fluid, such as dirt, corrosion, impurities of temperature.

Balanced bellows

Series	441, 441 Full nozzle	XXL	458
Design			

Bonnet spacer	*	-	*
Bellows housing	-	*	*
The bellows housing protects the bellows against turbulences during discharge to avoid bellows vibration and to guarantee a longer life-time.			
Control thread	DIN ISO 228-1, G 1/4	*	*
	ASME B1.20.1 NPT 1/2	✓	✓

A control thread DIN ISO 228-1 size G 1/4 is fitted into the bonnet to monitor the condition of the bellows.
A discharge pipe can be fitted to the G 1/4 control thread to allow safe discharge of aggressive or toxic fluids.

Option code			
Open bonnet	Standard bellows	J68	J68
	Low pressure bellows	J68, J63	J68, J63
	Other materials than stand.	S15 + material designation	S15 + material designation
Closed bonnet	Standard bellows	J78	J78
	Low pressure bellows	J78, J63	J78, J63
	Other materials than stand.	S15 + material designation	S15 + material designation
	Control thread NPT 1/2	J95	J95

The dimensions and weights of a safety valve with balanced bellows are displayed in the tables "Dimensions and weights" for each type. The set pressure range as well as the temperature range are displayed in the tables "Pressure temperature ratings" for each type.

Balanced bellows – Subassembly item 15

Materials		Standard bellows		
Item	Component	Series 441, 441 Full nozzle	Series XXL	Series 458
15.1	Lower adaptor	1.4404	1.4404	1.4404
		316L	316L	316L
15.2	Upper adaptor	1.4404	1.4571	1.4404
		316L	316Ti	316L
15.3	Bellows	1.4571	1.4571	1.4571
		316Ti	316Ti	316Ti
15.5	Housing	–	1.4571	see item 11
		–	316Ti	–
11	Bonnet spacer	1.4404	–	1.0460 or 1.4404
		316L	–	Carbon steel or 316L
55	Studs	1.4401	1.4401	1.4401
		B8M	B8M	B8M
60	Gaskets	Graphite / 1.4401	–	Graphite / 1.4401
		Graphite / 316	–	Graphite / 316

Hastelloy bellows or special materials are available on request.

Materials		Special bellows		
Hastelloy®		✓	✓	✓
Inconel®		✓	✓	✓

Balanced bellows conversion kits

LESER balanced bellows conversion kits are available to convert from a conventional design into a balanced bellows design with little effort. The conversion kits contain all the necessary parts for conversion as well as instructions.

Conversion kits				
Item	Component	Quantity	Material	Remarks
8	Guide	1	1.4404	
			316L	
11	Bonnet spacer	1	1.4404	
			316L	
12	Spindle	1	1.4404	
			316L	
15	Bellows	1	1.4571	
			316Ti	
55	Stud	4, 8, 12 depends on valve size	1.4401	
			B8M	
60	Gasket	2, 3 depends on valve size	Graphite / 1.4401	
			Graphite / 316	
–	Installation instruction	1		LWN 037.05

For article no. and spare parts please refer to spare part page for each type.

High temperature equipment

For fluid temperatures higher than 400 °C / 752 °F high temperature equipment is necessary to protect the inner parts and the spring against inadmissible influence of temperature. The maximum inlet temperature is 550 °C / 1022 °F. The equipment shown is only fitted in Type 457 / 458. For all other Types an open bonnet and a stainless steel bellows is necessary for fluid temperatures exceeding 400 °C / 752 °F up to max. 450 °C / 842 °F.

Specification

Series 458

Design

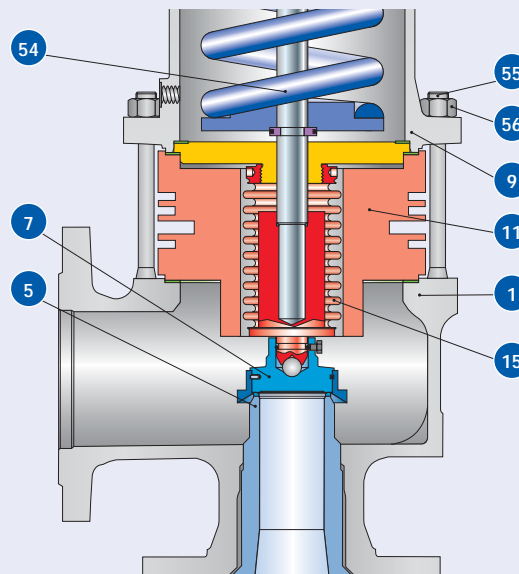

Option code

J88

Operating conditions

Temperature limits	[°C]	> 400 fluid temperature
	[°F]	> 752 fluid temperature
	max. [°C]	550 inlet temperature
	max. [°F]	1022 inlet temperature

Materials

High temperature equipment

Item	Component	
1	Body	1.7357
		WC6
5	Nozzle	1.4404
		316L
7	Disc	1.4404 stellited
		316L stellited
9	Bonnet open	1.0619
		WCB
11	Cooling spool	1.4404
		316L
15	Bellows	1.4571
		316L
54	Spring	1.7102, 1.8159
		High temperature alloy steel
55	Studs	1.7709
		B16
56	Nuts	1.7258
		7M

Elastomer bellows

Application

Elastomer bellows reliably seal the bonnet from the outlet chamber, protecting the guides, moving parts and the spring from problems associated with the media, such as dirt, corrosion or impurities, which can cause the valve to fail. The elastomer bellows is a cost effective alternative to the stainless steel bellows.

The range of application for the elastomer bellows is limited by:

- chemical resistance of the bellows
- fluid temperature
- set pressure
- back pressure

Elastomer bellows

Design

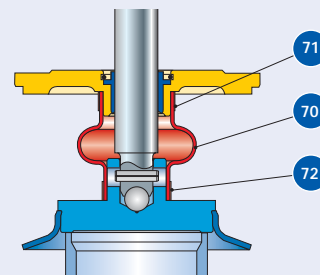

Bellows design	The bellows simple, compact, single wall design allows it to be used in small relieving spaces. Its one-piece construction also allows to be easily replaced and extends its service life.
Flexibility	The bending of the elastomer bellows provides maximum flexibility for spindle movement and reduces wear.
Bonnet vent	A control bore Ø 10 mm / 0,4 inch is designed in the bonnet to vent and to monitor the tightness of the bellows.
Design height	No alteration.

Materials

Valve size		DN 20 – 65	DN 80 – 150	DN 20 – 150
Option code		J79	J79	J87
Item	Component			
70	Elastomer Bellows	70 EPDM 281	55 EPDM 259	45 NBR 670 optional
		---	---	---
71	Hose clamp	1.4301	1.4301	1.4301
		304	304	304
72	Hose clamp	1.4301	1.4301	1.4301
		304	304	304

Operating conditions

Temperature limits	[°C]	-50 up to +130	-50 up to +130	-25 up to +100
	[°F]	-58 up to +266	-58 up to +266	-13 up to +212
Set pressure	max. [bar _g]	10		
	max. [psig]	145		
Built-up back pressure	[bar _g]	up to 3		
	[psig]	up to 43,5		

Disc – Subassembly item 7

Disc with detachable lifting aid

As a variation on the standard disc with an integrally fixed lifting aid, a detachable lifting aid for the disc can be supplied if requested. The advantage when servicing the safety valve is that damage to the sealing surface can be rectified on site by removal and lapping.

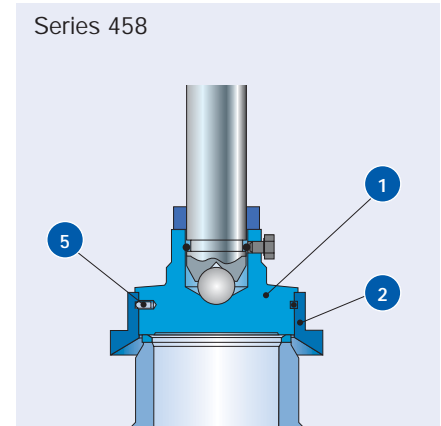
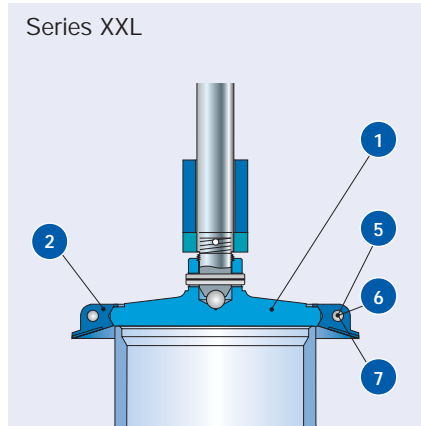
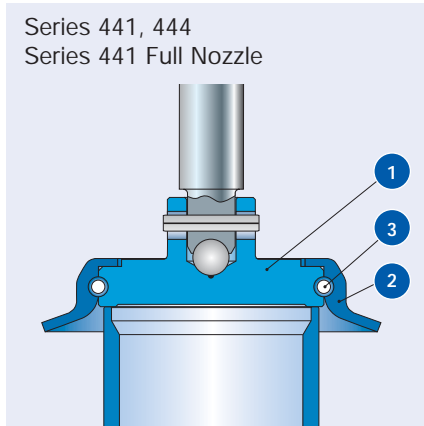

Materials see page 99/19.

Bull race disc

To avoid damages on the sealing surfaces due to frequent dismantling, specially on safety valves which have shortand/or regular maintenance intervals, a bull race disc can be supplied. For Series 458 a bull race disc is standard.

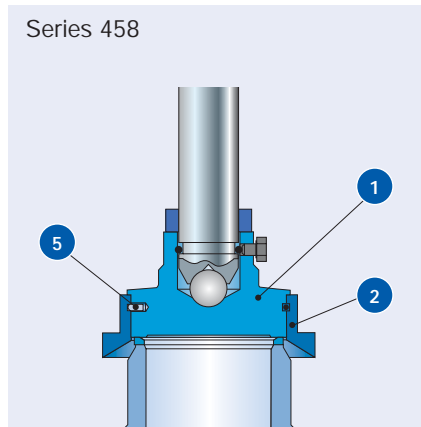
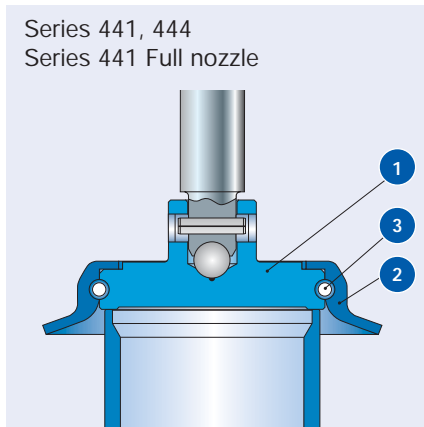

Availability						
Type	441, 442 DIN 441, 442 ANSI	441, 442 XXL	444 DIN 444 ANSI	441 Full nozzle DIN 441 Full nozzle ANSI 442 Full nozzle DIN 442 Full nozzle ANSI	455/456	457/458
Disc	Option code					
Disc with detachable lifting aid	J26	*	*	J26	*	*
Bull race disc	J24	J24	J24	J24	*	*

Disc – Subassembly item 7

Materials		Disc with detachable lifting aid	
Item	Component	Standard service	Corrosive service
Series 441, 441 Full nozzle			
1	Disc	1.4122 hardened	1.4404
		Hardened stainless steel	316L
2	Lifting aid	1.4581	1.4581
		CF10M	CF10M
3	Rollpin	1.4310	1.4310
		Stainless steel	Stainless steel
Series XXL			
1	Disc	1.4404	1.4404
		316L	316L
2	Lifting aid	1.4581	1.4581
		CF10M	CF10M
5	Screw	1.4401	1.4401
		Stainless steel	Stainless steel
6	Nut	1.4401	1.4401
		Stainless steel	Stainless steel
7	Washer	1.4401	1.4401
		Stainless steel	Stainless steel
Series 458			
1	Disc	1.4122 hardened	1.4404
		Hardened stainless steel	316L
2	Lifting aid	1.4404	1.4404
		316L	316L
5	Securing ring	1.4571	1.4571
		316Ti	316Ti

Heating jacket

Application and design

Safety valves in systems which need to be protected from media that are viscous, sticky, or have the tendency to crystallize out of solution can be fitted with a heating jacket.

The heating jacket is constructed with a welded design and covers the body, allowing heating medias (steam, heat transfer oil, etc.) to pass through the space created.

To protect the spindle and the moving parts against sticking LESER recommends the use of a heating jacket in combination with the balanced bellows design.

For safety valves with balanced bellows, the bonnet spacer required to house the bellows is fitted with an additional heating jacket. Both heating jackets are joined by a tubing.

If there is no risk of solidification of the media at the outlet a safety valve without balanced bellows can be used as well.

The position of the heating connections is shown in figure 1 to 3.

Specifications of the Heating Jacket

The operating data for the heating jacket are shown on a separate name plate.

Slip on flanges

Flanged heating connections are supplied as slip on flanges for better alignment of the flange connection.

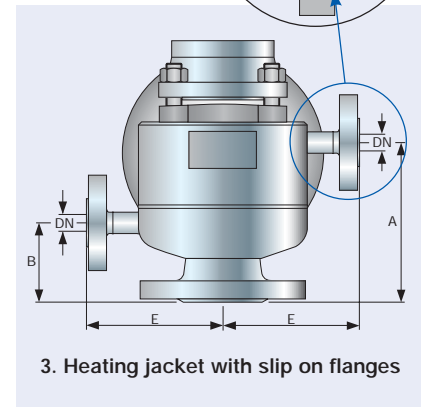
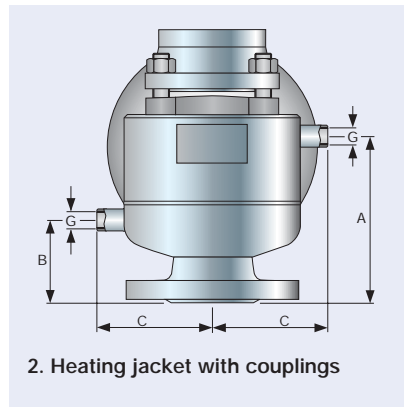
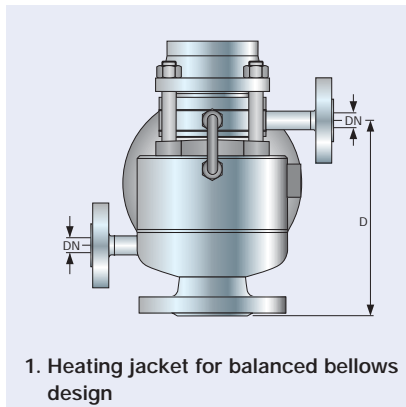
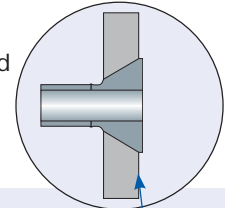

Heating jacket												
	DN _i	25	32	40	50	65	80	100	125	150	200	≥ 250
	Valve size inlet	1"	1 1/2"	1 1/2"	2"	2 1/2"	3"	4"	5"	6"	8"	≥ 10"
	Actual Orifice diameter d ₀ [mm]	23	29	37	46	60	74	92	98	125	165	≥ 200
Materials												
Body	Series 441					1.4408	1.4408	1.4408	1.4408	1.4408		
	Series 441 Full nozzle	1.4408	1.4408	1.4408	1.4408	optional 1.0619	optional 1.0619	optional 1.0619	optional 1.0619	optional 1.0619	1.0619	-
	Series XXL	-	-	-	-	-	-	-	-	-	1.0460 1.0425	1.0460 1.0425
	Series 458	1.4581	1.4581	1.4581	1.4581	optional 1.0619	optional 1.0619	optional 1.0619	optional 1.0619	optional 1.0619	-	-
Heating jacket								1.4541 321				
Connections												
Slip on flange	Option code	DN 15, PN 25	1.4571, 1.4404						-			
			316Ti, 316L						-			
DIN	Option code	DN 25, PN 25	-						1.4571, 1.4404			
			-						316Ti, 316L			
Slip on flange	Option code	1/2", CL150	1.4404						-			
			316L						-			
ANSI B16.5	Option code	1", CL150	-						1.4404			
			-						316L			
Couplings	Option code	G 3/8							1.4571			
									316Ti			
DIN 2986	Option code	G 3/4							1.4571			
									316Ti			
Heating jacket spacer	Option code	H 33							1.4404			
									316L			

Heating jacket

Metric Units												
	DN _i	25	32	40	50	65	80	100	125	150	200	≥ 250
	Valve size inlet	1"	1 1/2"	1 1/2"	2"	2 1/2"	3"	4"	5"	6"	8"	≥ 10"
	Actual Orifice diameter d ₀ [mm]	23	29	37	46	60	74	92	98	125	165	≥ 200
Series 441, Series 441 Full nozzle, Series XXL						Dimensions						
[mm]	A	115	130	160	160	200	165	160	170	390	on request	on request
	B	70	70	75	80	90	80	80	125	125	on request	on request
	C	95	95	110	110	135	145	145	162	162	on request	on request
	D	152	170	198	220	255	300	300	370	445	on request	on request
	E	121	121	121	136	161	176	176	200	200	on request	on request
	Slip on flange DN	15	15	15	15	15	25	25	25	25	25	25
[inch]	Couplings G	3/8	3/8	3/8	3/8	3/8	3/4	3/4	3/4	3/4	3/4	3/4
Operating conditions						Operating pressure [bar]						
Operating temperature	20°C	25	25	25	25	15	15	15	15	12	12	on request
	300°C	18	18	18	18	11	11	11	11	9	9	on request
Series 458						Dimensions						
[mm]	A	130	-	-	170	-	on request	on request	-	-	-	-
	B	88	-	-	112	-	on request	on request	-	-	-	-
	C	96	-	-	123	-	on request	on request	-	-	-	-
	D	185	-	-	251	-	on request	on request	-	-	-	-
	E	122	-	-	149	-	on request	on request	-	-	-	-
	Slip on flange DN	15	-	-	15	-	on request	on request	-	-	-	-
[inch]	Couplings G	3/8	-	-	3/8	-	on request	on request	-	-	-	-
Operating conditions						Operating pressure [bar]						
Operating temperature	20°C	25	-	-	15	-	15	12	-	-	-	-
	300°C	18	-	-	11	-	11	9	-	-	-	-

US Units												
	DN _i	25	32	40	50	65	80	100	125	150	200	≥ 250
	Valve size inlet	1"	1 1/2"	1 1/2"	2"	2 1/2"	3"	4"	5"	6"	8"	≥ 10"
	Actual Orifice diameter d ₀ [mm]	23	29	37	46	60	74	92	98	125	165	≥ 200
Series 441, Series 441 Full nozzle, Series XXL						Dimensions						
[inch]	A	4 1/2	5 1/8	6 5/16	6 5/16	7 7/8	6 1/2	6 5/16	6 11/16	15 3/8	on request	on request
	B	2 3/4	2 3/4	3	3 1/8	3 1/2	3 1/8	4 1/2	5	5	on request	on request
	C	3 3/4	3 3/4	4 5/16	4 5/16	5 5/16	5 11/16	6 3/8	6 3/8	6 3/8	on request	on request
	D	6	6 11/16	7 13/16	8 11/16	10 1/16	11 3/4	13 3/8	14 5/8	17 1/2	on request	on request
	E	4 3/4	4 3/4	4 3/4	5 3/8	6 3/8	6 15/16	7 7/8	7 7/8	7 7/8	on request	on request
	Slip on flange DN _i	1/2	1/2	1/2	1/2	1/2	1	1	1	1	1	1
[inch]	Couplings G	3/8	3/8	3/8	3/8	3/8	3/4	3/4	3/4	3/4	3/4	3/4
Operating conditions						Operating pressure [psig]						
Operating temperature	68°F	363	363	363	363	217	217	217	217	174	174	on request
	572°F	261	261	261	261	160	160	160	160	131	131	on request
Series 458						Dimensions						
[inch]	A	130	-	-	170	-	on request	on request	-	-	-	-
	B	88	-	-	112	-	on request	on request	-	-	-	-
	C	96	-	-	123	-	on request	on request	-	-	-	-
	D	185	-	-	251	-	on request	on request	-	-	-	-
	E	122	-	-	149	-	on request	on request	-	-	-	-
	Slip on flange DN	1/2	-	-	1/2	-	on request	on request	-	-	-	-
[inch]	Couplings G	3/8	-	-	3/8	-	on request	on request	-	-	-	-
Operating conditions						Operating pressure [psig]						
Operating temperature	68°F	363	-	-	217	-	217	174	-	-	-	-
	572°F	261	-	-	160	-	160	131	-	-	-	-

O-ring damper – Subassembly item 40

The O-ring damper can be employed to suppress or reduce oscillations of moving parts in a safety valve.

Background:

In every spring loaded safety valve the movable parts disc, spindle, lower spring plate and the spring form a so called spring-mass system. As with all spring-mass systems, these parts can become excited by unfavorable operating conditions (e.g. inlet pressure drop) or by vibrations transferred from other equipment. Vibrations occurring at resonance frequency can cause the safety valve to undergo rapid, uncontrolled opening and closing, which will cause the valve to function improperly and not allow it to relieve the certified capacity.

In general two kinds of uncontrolled oscillations exists (definitions according to ASME PTC 25-2001, chapter 2.7):

chatter: “Abnormal rapid reciprocating motion of the movable parts of a pressure relief valve in which the disc contacts the seat.” Causes for chattering are, among other things, high pressure losses in the inlet piping, excessive built-up back pressure and operation of the valve in the partial load range.

flutter: “Abnormal rapid reciprocating motion of the movable parts of a pressure relief valve in which the disc does not contact the seat.” Causes for fluttering are vibrations with small or hardly measurable amplitude, where high frequency vibrations accumulate from external influences. The vibrations are usually induced by separate units (e.g. motors, pumps) and transmitted via a mechanical connection or the medium to the safety valve.

LESER developed the O-ring damper at LESER’s certified test labs based on long experience in the operation of safety valves. The O-ring damper is able to completely stabilize function or reduce oscillations to slow, uncritical movements. Also, the safety valve will still operate within the required ranges of the applicable codes and standards. Due to its design, the O-ring damper is able to be used for any type of oscillation.

LESER offers the O-ring damper incorporated in the gastight cap H2 or in a modified lifting device H4 with packed lever. For applications with lubricating fluids, e.g. oil, the balanced bellows design must be selected to protect the O-ring damper from the fluid.

Available designs

		Cap H2	Packed lever H4
Design			
Option code	Conventional design	J65	J66
	Balanced bellows design	J65, J78	J66, J78
Temperature range O-ring		-20 °C – +180 °C -4 °F – +356 °F	

O-ring damper – Subassembly item 40

Availability	
Cap H2 and Packed lever H4	
Valve size	Pressure range
Series 441	
DN 25 – DN 50	0,5 – 40 bar
1" – 2"	7,25 – 580 psig
DN 65	0,26 – 40 bar
2 1/2"	3,77 – 580 psig
DN 80	0,60 – 22,5 bar
3"	8,70 – 326 psig
DN 400	1,17 – 19,2 bar
4"	17 – 278 psig
Series 458	
DN 25, d ₀ 20	30 – 90 bar
1", d ₀ 20	435 – 1305 psig
DN 50, d ₀ 40	32 – 67 bar
2", d ₀ 40	464 – 971 psig

LESER has ensured proper performance of the O-ring damper through extensive tests at its certified test labs. If an O-ring damper is required for a set pressure not listed in the table above further testing must be performed, which will require a longer lead time; please contact sales@leser.com.

Materials		Cap H2	Packed lever H4
Item	Component		
1	Lever cover	–	1.4408
		–	CF8M
2	Cap H2	1.4404	1.4404
		316L	316L
13	Parallel pin	–	1.4401
		–	B8M
14	Securing ring	–	1.4571
		–	316Ti
15	Spindle	–	1.4404
		–	316L
22	Opposite ring	1.4404	1.4404
		316L	316L
27	Bush	1.4404	–
		316L	–
27	Nozzle	–	PFTE 15% glas
		–	–"
82	Spring	1.4310	1.4310
		Stainless steel	Stainless steel
83	O-ring	Viton®	Viton®
		–"	–"

Lift indicator

The lift indicator is a useful device that can be used in process control to monitor the operating status of a safety valve.

To detect lifting, LESER provides a special lifting device H4 incorporating a proximity switch (see drawing right).

The lift indicator will detect a safety valve lift equal to or more than 1 mm / 0.04 in, which may be the result of overpressure or of operation of the lifting device.

LESER provides inductive DC proximity switches, type DIN EN 60947-5-6 (NAMUR) using two-wire technology. These intrinsically safe proximity switches can be used in explosion hazard area zone 0 (Ex II 1 D Ex iaD 20 T6). Other types of proximity switch may be used. If a technical specification is supplied along with the type of connection thread LESER can verify compatibility.

For technical details of proximity switch refer to manufacturers homepage: www.pepperl-fuchs.com

For assembly and adjustment refer to LESER works standard LWN 323.03-E.

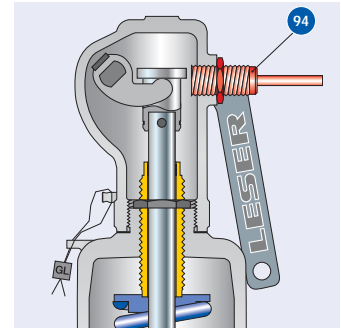

Packed lever H4 or bolted H6

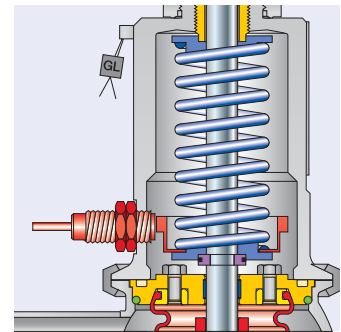

Type 444 DN 25 / 1":
Bonnet with adaptor for lift indicator

Availability

Item	Component	Option code
9	Bonnet with adaptor for lift indicator	J38
40	Lifting device H4 with adaptor for proximity switch M18 x 1 [mm]	J39
94	Lift indicator M18 x 1, used type = PEPPERL+FUCHS NJ5-18GK-N	J93

Operating chart

A, closed position

The lift indicator is positioned in front of the coupling or control sleeve when the safety valve is closed.

B, open position

When the safety valve opens or is lifted (in both cases at least 1 mm / 0,04 inch), the lift indicator changes its signal. The signal also changes if the lift indicator accidentally becomes loosened or unscrewed (fail safe).

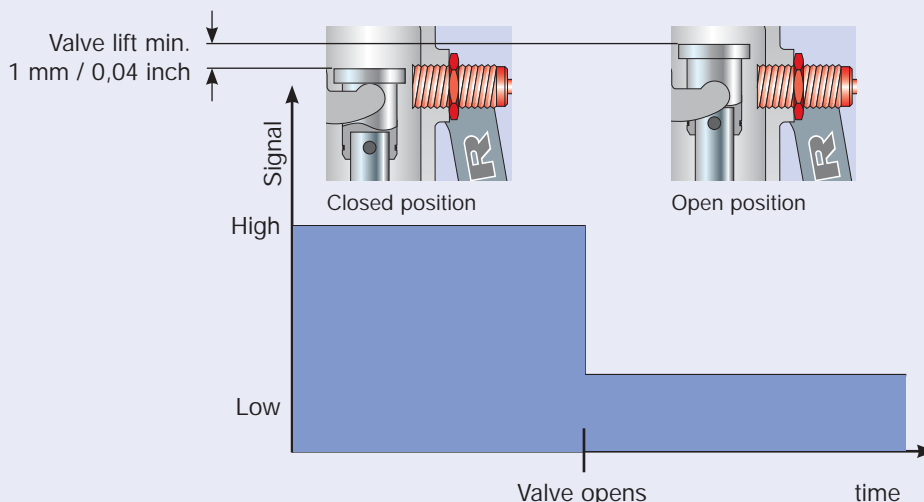

Lift restriction (lift restraining device)

A lift restriction may be needed to reduce the certified discharge capacity of a safety valve to the required discharge capacity. The lift restriction does not interfere with the operation of the valve.

If a lift restriction is used the following requirements of codes and standards must be considered.

Requirements			
Code / standard	EN ISO 4126-1, section 5.1.3	ASME Code case 1945-4	AD 2000-Merkblatt A2, section 10.3
Lift	≥ 30% full rated lift not less than 1,0 mm / 1/16 inch	≥ 30% full rated lift not less than 0,08 inch / 2,0 mm	not less than 1,0 mm / 1/16 inch
Coefficient of discharge	-	-	$\alpha_w [S/G] \geq 0,08$
	-	-	$\alpha_w [L] \geq 0,05$
Name plate marking	Marking of reduced coefficient of discharge	- Capacity replaced with "Restricted capacity" - Restricted lift = ____ inch / mm	Marking of reduced coefficient of discharge
Design according to ASME code case 1945-4	The restriction of valve capacity shall be permitted only by the use of a lift restraining device, which shall limit valve lift and shall not otherwise interfere with flow throughout of the valve. The lift restricting device shall be designed so that the adjustable feature can be mechanically locked and have access sealed.		

Determinating the restricted lift

Determining the restricted lift can be done by using:

- the "Diagram for evaluation of ratio of lift / flow diameter (h/d₀) in reference to the coefficient of discharge". An explanation on how to use this diagram may be found on page 00/08.
- LESER sizing program "VALVESTAR®"
- LESER sizing web page www.valvestar.com

Lift restrictions

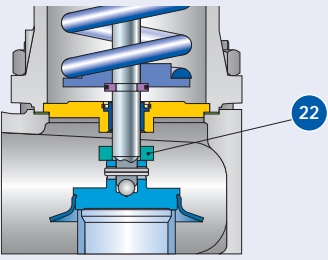
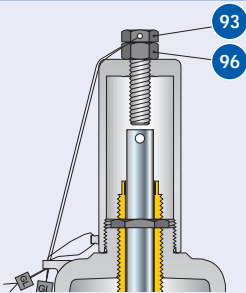
	Lift restriction by bush	Lift restriction by gag
Design		
Option code	J51	Cap H2 or H1: J52 Packed lever H4 or H6: J50
Availability		
Series 441	✓	✓
Series 444	✓	✓
Series XXL	✓	✓
Series 441 Full nozzle	✓	✓
Series 458	✓	✓
Materials		
Item	Component	
22	Bush	1.4404
		316L
93	Stud	-
		1.4401 B8M
96	Hex nut	-
		1.4401 8M

... a not so brief history of LESER

Headquartered in Germany, with a state of the art factory and more than 300 employees LESER are supplying high quality safety valves all over the world.



The company started in Germany in 1818, more than 185 years ago, as a brass foundry and developed a product portfolio of components of mechanical equipment and machines during the "industrial revolution".

In 1885 the company delivered its first safety valve and since the 1970's LESER has specialized only in safety valves.

Since the 1980's LESER has been the leading supplier for safety valves in Europe and strengthens this position each year. Currently LESER are expanding its activities worldwide.

Safe solutions from the specialist

Today, LESER's product range comprises a total of 7 product groups with 38 safety valve types. A variety of materials and sizes from DN 10 to DN 400 – 1/2" to 16", provide safe solutions for almost every industrial application.

High Performance:

Safety valves of this design are generally installed for protection of pressure vessels and industrial systems (gas, steam and liquid applications) by providing rapid discharge of the maximum possible mass flow.

API:

Safety valves according to the API Standard 526; predominantly applicable for the petrochemical and chemical industries.

Compact Performance:

Safety valves for protection of small and medium mass flows for traditional applications like pumps and compressor, but also adapted for cryo applications.

Clean Service:

Safety valves for protection of systems with sanitary and hygienic requirements in the food, beverage and pharmaceutical industries.

Critical Service:

Safety valves partially or fully lined typically with PTFE, suitable for aggressive and corrosive media.

Modulate Action:

Safety valves which are installed for protection of small mass flow predominantly for liquids to assure a minimization of the media losses. Suitable for thermal relief applications.

Best Availability: Other complimentary product series such as supplementary loading systems, change-over valves and bursting discs which complete the LESER product offering.



Why LESER?

Short delivery: Extensive stocks of LESER products are maintained in more than 20 countries to guarantee short delivery lead times worldwide. Most spares can be shipped overnight.

German manufacturing and assembly worldwide: LESER safety valves are manufactured exclusively in Germany by LESER! A certified and well-trained network close to LESER's customers provides assembly and setting services with a short response time. This guarantees a superior quality level worldwide.

New safety valve development: LESER continually improve existing valve lines and develop new valve models to fulfill customers' demands. The LESER R&D Team consists of over 30 people.

Proven technology: LESER operates three flow testing laboratories with ASME and TÜV certification, which are among the biggest facilities in the world. The simulation of customer plant configuration for safe solutions in special cases is daily business at LESER.

Special Solutions: LESER's extensive engineering capabilities combined with most modern in-house manufacturing equipment provide quick delivery of special solutions. We design, build and test according to your specification.

Installed base: By number LESER have the largest installed base of safety valves throughout the world. Currently LESER produce 75.000 safety valves per year. This installed base guarantees reliability for customers.

Focus on Safety Valves: LESER is a privately owned company that is totally focussed on design and manufacturing of one product: safety valves. This ensures LESER's commitment to your safety valve requirements.

All LESER Safety Valves carry CE and ASME



LESER information tools provide you with all product-related information you need:

- Applications
- Features and benefits
- How to orders
- Codes and standards
- Materials
- Dimensions and weights

- Pressure ranges
- Temperature ranges
- Options
- Spare parts
- Approvals
- Capacity tables

Simply state the number of required copies or get a pdf file.

Your request will be processed immediately.

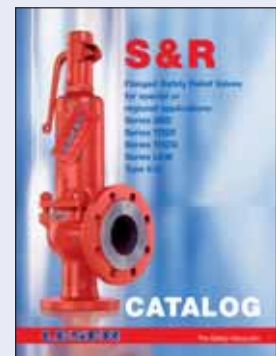
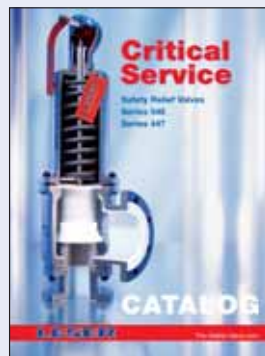
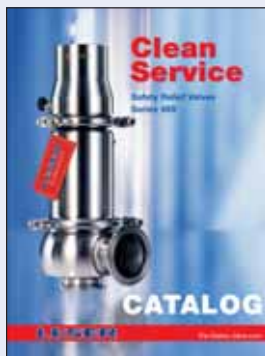
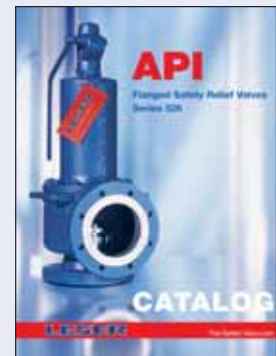

Order information:

Please send your request to your local representative or contact LESER GmbH & Co. KG:

Fax: +49 (40) 251 65-500

(Please use our Fax Order document)

E-Mail: sales@leser.com

Please send your request to our Sales Center

To: **LESER GmbH & Co. KG**

Fax: +49 (40) 251 65-500

Date: _____

From: _____

Catalog order:

High Performance [Catalog 1](#)

Flanged Safety Relief Valves

Series 441
Series XXL
Series 444

 pdf

 Printed version

No. of copies: _____

High Performance [Catalog 2](#)

Flanged Safety Relief Valves

Series 441 Full nozzle
Series 458

 pdf

 Printed version

No. of copies: _____

Compact Performance

Threaded Safety Relief Valves

Series 437
Series 459

 pdf

 Printed version

No. of copies: _____

API

Flanged Safety Relief Valves

Series 526

 pdf

 Printed version

No. of copies: _____

Clean Service

Safety Relief Valves

Series 48X

 pdf

 Printed version

No. of copies: _____

Critical Service

Safety Relief Valves

Series 447
Series 546

 pdf

 Printed version

No. of copies: _____

Modulate Action

Flanged Safety Relief Valves

Series 429
Series 433

 pdf

 Printed version

No. of copies: _____

S & R

Safety Relief Valves
for special or regional
applications

Series L & W
Series TRDF
Series TRDG
Series SBD
Type 612

 pdf

 Printed version

No. of copies: _____

CD order:

VALVESTAR®

- Ultimate sizing program
- Consideration of all relevant codes and standards
- Comprehensive documentation (sectional drawings, parts lists)
- Different language versions
- Help function

No. of copies: _____

Addressee

Please send the requested copies to:

Name: _____

Company: _____

Address: _____

E-Mail: _____

High Performance Catalog 1
Edition September 2006

LWN 482.01-E / 09.2006 / 3000

LESER

The-Safety-Valve.com

LESER GmbH & Co. KG

20537 Hamburg, Wendenstr. 133-135
20506 Hamburg, P.O. Box 26 16 51

Fon +49 (40) 251 65-100
Fax +49 (40) 251 65-500

E-Mail: sales@leser.com
www.leser.com