

# Best Availability

Change-over valves

Type 310

Type 311 XXL



# CATALOG

**LESER**

The-Safety-Valve.com

LESER Change-over and safety valves for any industrial application

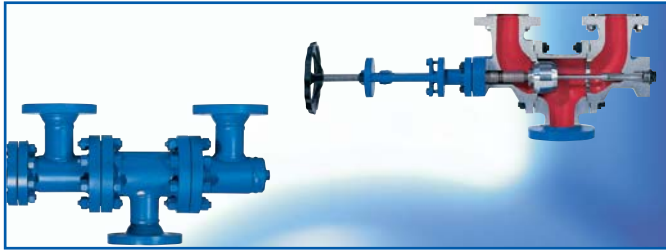

**Best Availability  
Change-over valves**



**High  
Performance**

Type 310  
Type 311 XXL



**API**



**Clean Service**



**Critical  
Service**



**Modulate  
Action**



**Compact  
Performance**

Overview	Chapter/Page
<b>General Information</b>	<b>00/01</b>
Applications, General design features	00/02
Terms	00/03
General notes	00/04
Pressure loss	00/05
How to order – order form	00/07

LESER Type	Chapter/Page
<b>Type 310</b>	<b>01/01</b>
<b>Designs and materials</b>	<b>01/01</b>
Gland design	01/01
Bellows design	01/01
<b>Materials</b>	<b>01/02</b>
General components	01/02
Bellows design, specific	01/02
<b>Article numbers and weights, pressure loss coefficient and flow efficiency coefficient</b>	<b>01/03</b>
<b>Dimensions – Metric + US units</b>	<b>01/04</b>
<b>Order information – spare parts</b>	<b>01/05</b>

LESER Type	Chapter/Page
<b>Type 311 XXL</b>	<b>02/01</b>
<b>Designs and materials</b>	<b>02/01</b>
Gland design	02/01
Bellows design	02/01
<b>Materials</b>	<b>02/02</b>
General components	02/02
Bellows design, specific	02/02
<b>Article numbers, dimensions and weights, pressure loss coefficient and flow efficiency coefficient</b>	<b>02/03</b>
<b>Order information – spare parts</b>	<b>02/03</b>

<b>Combinations and reducers</b>	<b>03/01</b>
Change-over valve combinations	03/01
Reducers	03/03

<b>Options</b>	<b>04/01</b>
Flange drillings and facings	04/01
Available options	04/01

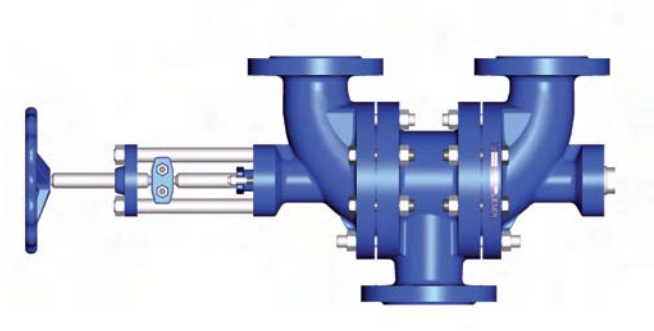

**Type 310**  
Gland design

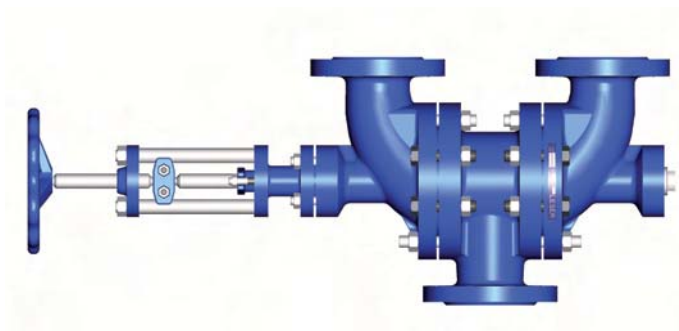

**Type 310**  
Bellows design

## LESER – Change-over valves

The change-over valve product stands for:

- ✓ Uninterrupted operation
- ✓ Easy handling
- ✓ Robust design

### Why change-over valves?

Change-over valves are used to connect two safety valves to a pressure system using one pipe joint. Here, one safety valve is in operation and one safety valve is on stand-by. The stand-by safety valve can be removed during ongoing operation and be serviced, for instance, while protection of the pressure system against inadmissible pressures is maintained.

### LESER – Change-over valves

- facilitate a productivity increase of the plant due to the uninterrupted operation, which means
  - reduction of service time and costs
  - reduction of production downtime
- are specifically designed for combination with LESER safety valves.
- are available as
  - individual valve
  - inlet-sided combination with safety valves
  - lockable combination with safety valves

- can be equipped with reducers so that individual adaptations to plant conditions are possible.
- are constantly further developed in close cooperation with plant engineers and service specialists.
- are characterised by longstanding proof in service.
- are equipped with service-free seats which reduces service costs.
- have a compact construction for space-saving installation.
- have a flow-optimised design that leads to low pressure losses in the inlet line. That way, the safety valve works more stable, and also allows to use a change-over valve with the nominal size of the safety valve where applicable.
- have very easy handling and as a result, they are foolproof.
- guarantee the full flow area when changing over and therefore meet all regulatory requirements.

Change-over valves and safety valves from LESER facilitate coordinated planning, delivery and sizing.

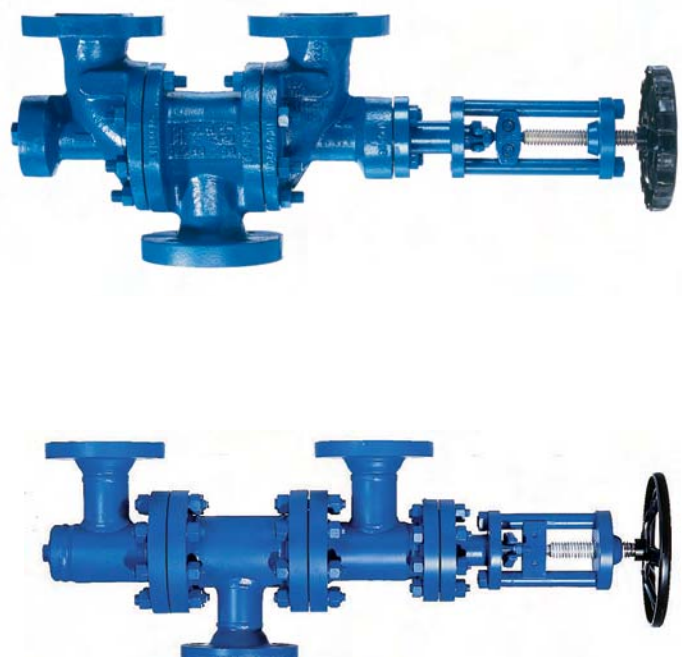
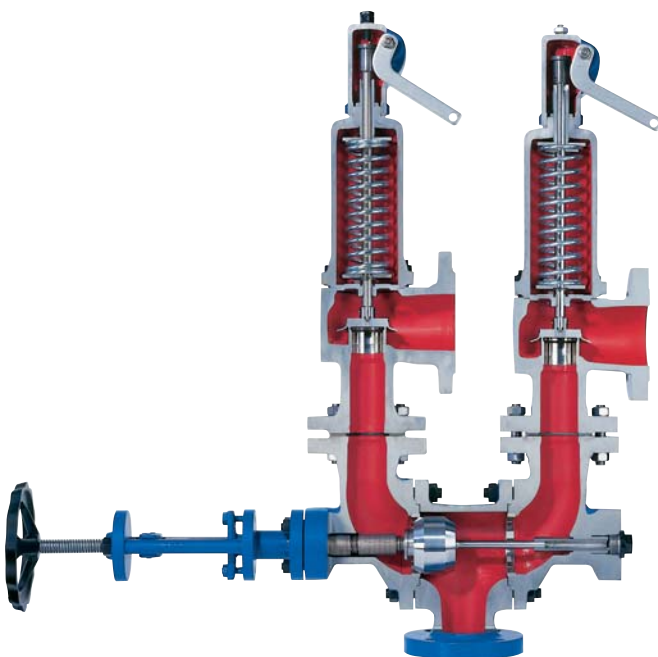

## Applications

### LESER – Change-over valves

LESER change-over valves provide the solution for a continuous operation of plants.

They are deployed in processes

- in which shutting down the plant is not possible.  
Examples are:
  - large natural deposits (e.g. natural gas)
  - storage tanks for technical gasses (e.g. ethylene storage)
- in which shutting down the plant is not desired due to the high technical effort. Shutting down can cause media to harden, stick, or solidify. Examples are:
  - bitumen plants
  - oil fields
  - ethylene plants
- in which shutting down the plant is not wanted in order to guarantee continuous operation, such as
  - refineries

### Design features

- 13 valve sizes from DN 25 – DN 500 / NPS 1" – 20" with EN and ASME flanged connections
- Flange classes PN 25 – PN 160 / CL150 – CL900
- Body materials are:

	Steel		Stainless steel	
<b>Type 310</b>	1.0619	WCB	1.4408	CF8M
<b>Type 311 XXL</b>	1.0425	Steel	1.4571	316Ti

- Materials that deviate from the standard are possible, e.g. Duplex, LCB, LCC or CF3M
- The temperature range of the change-over valves facilitate use in numerous applications

According to DIN EN	Temperature ranges [°C]		Temperature ranges [°F]	
<b>Type 310</b>	-270°C	+450°C	-454°F	+842°F
<b>Type 311 XXL</b>	-196°C	+400°C	-321°F	+752°F
As per ASME	Temperature ranges [°C]		Temperature ranges [°F]	
<b>Type 310</b>	-268°C	+538°C	-450°F	+1000°F
<b>Type 311 XXL</b>	-184°C	+427°C	-300°F	+800°F

- spindle seal as a gland design and bellows design  
The bellows design meets the requirements of TA Luft
- compact design for low weight and space-saving installation
- conical disc, hence improved seat tightness
- stellited seat surface for low wear
- numerous accessories available for adaptation to the individual plant situation
- sour gas or NACE design possible
- heating jacket available for viscous media

### Worldwide Use

LESER change-over valves can be used worldwide.

They meet national and international regulatory requirements for change-over valves such as the following:

- Pressure equipment directive PED 97/23/EC
- AD 2000-Merkblatt
- GOST
- Canadian certification CRN

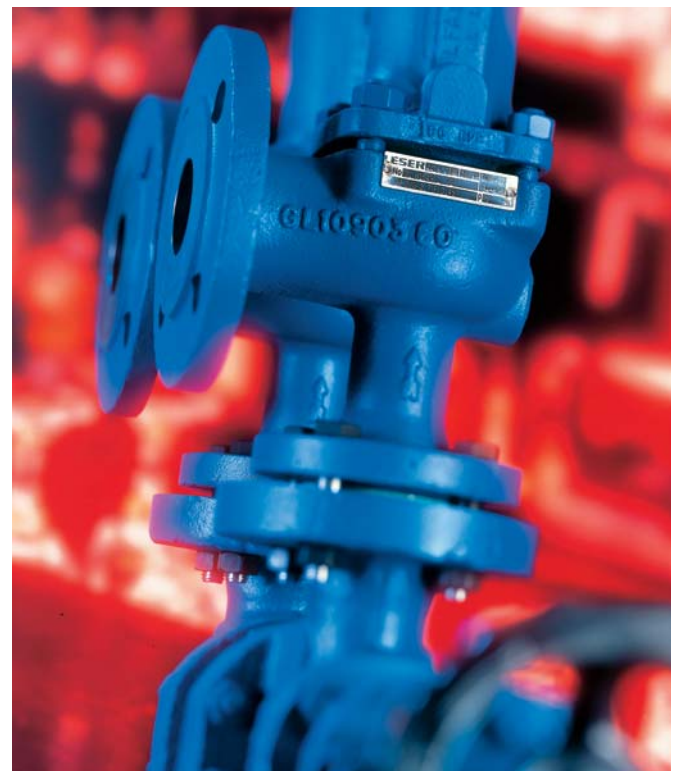

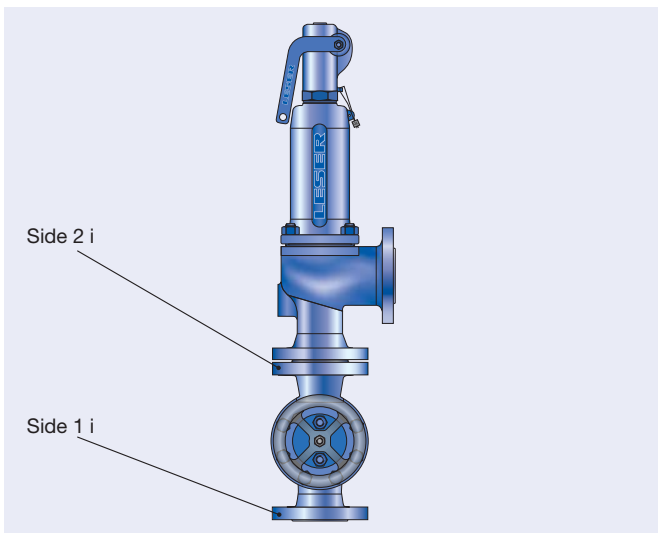
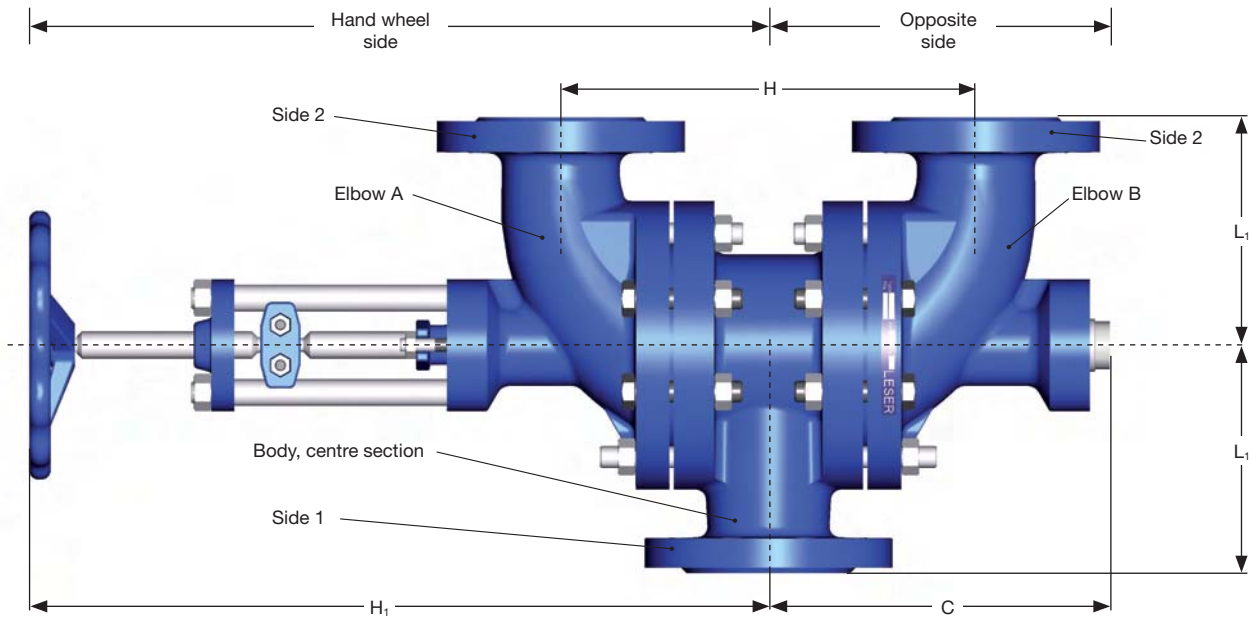

Inlet sided combination

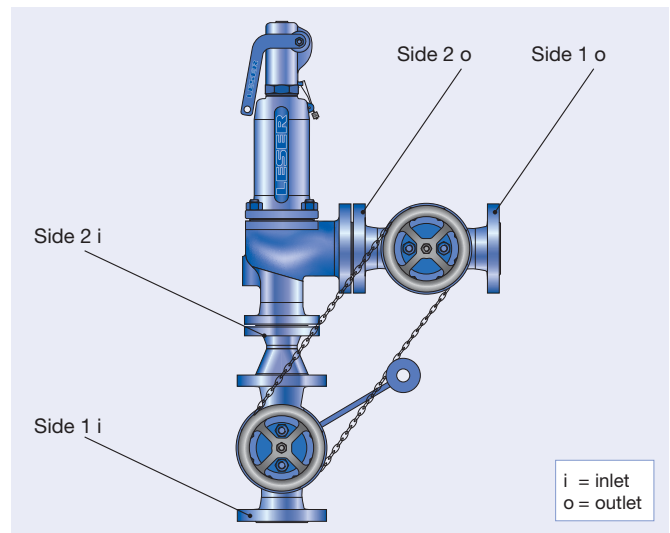

Lockable combination

Term	Explanation
<b>Change-over valve sides</b>	
<b>Hand wheel side</b>	Change-over valve side that faces the hand wheel
<b>Opposite side</b>	Change-over valve side that faces away from the hand wheel
<b>Connection name – inlet sided of change-over valve</b>	
<b>Side 1i</b>	Connection of change-over valve to inlet line
<b>Side 2i</b>	Connection of change-over valve to the side on the safety valve inlet
<b>Connection name – outlet sided of change-over valve</b>	
<b>Side 2o</b>	Connection of change-over valve to the side on the safety valve outlet
<b>Side 1o</b>	Connection of change-over valve to blow-down side
<b>Body components</b>	
<b>Elbow A</b>	Elbow on the hand wheel side
<b>Elbow B</b>	Elbow on the opposite side
<b>Body, centre section</b>	Centre piece of the change-over valve
<b>Fitting dimensions of change-over valve</b>	
<b>H</b>	The H dimension describes the distance from the centre of outlet elbow A to the centre of outlet elbow B. This dimension must be the same for the inlet sided and outlet sided change-over valve (only for lockable combination).
<b>H<sub>1</sub> + C</b>	The sum of the dimensions corresponds to the total width.
<b>L<sub>1</sub></b>	The L <sub>1</sub> dimension corresponds to the half-height of the change-over valve.

## Type-code and nominal diameters

LESER change-over valves come in two versions:  
Type 310 is a cast design with nominal diameters of DN 25 to DN 300 / NPS 1" to NPS 12".

Type 311 XXL is a welded design with nominal diameters of DN 400 and DN 500 / NPS 16" and NPS 20".

	Type 310											Type 311 XXL	
<b>DN</b>	25	40	50	65	80	100	125	150	200	250	300	400	500
<b>NPS</b>	1"	1½"	2"	2½"	3"	4"	5"	6"	8"	10"	12"	16"	20"

## State of LESER change-over valve on delivery

LESER generally closes the hand wheel side when the valve is delivered. This means that the side with the hand wheel is closed.

From the outside, the disc position can be recognised by the position indicating device. It is located between the column structure – in this position on the hand wheel side.

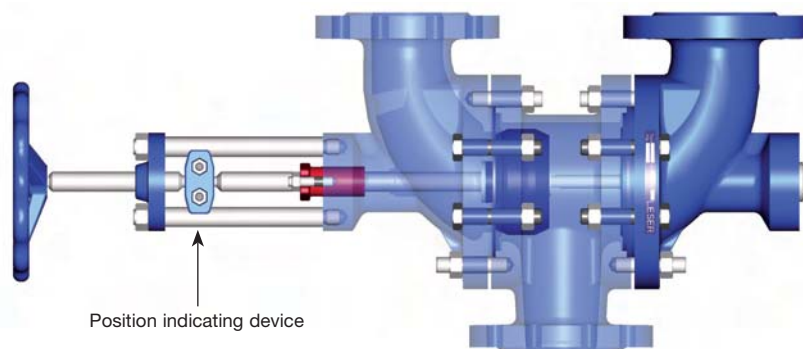

LESER change-over valve type 310 in delivery condition, hand wheel side closed

## Changing over the LESER change-over valve

The change-over is performed by turning the hand wheel. When doing this, make sure that the disc is completely changed over. To guarantee functioning in accordance to the regulatory requirements, it is not permitted to have the disc in the central position permanently!

If the disc is on the opposite side, i.e. the hand wheel side is open, then the position indicating device is on the side of the change-over valve.

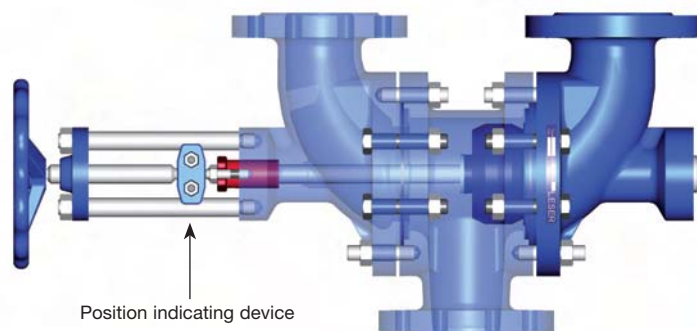

LESER change-over valve type 310 after changing over, opposite side closed

## Blowdown cross-section in the change-over phase

Codes and standards like ASME Sec. VIII Div. 1 UG-135 or AD 2000-Merkblatt A2 Par. 6 requires that even when changing-over, the required blow-down cross-section is free. This is ensured through the construction of LESER change-over valves.

## Removal of safety valves during operations

Through the use of a change-over valve, the stand-by safety valve can be removed during operations. Here, you must make sure that the safety valve to be removed is shut-off. This means the respective side of the change-over valve must be closed.

Before the removal of a safety valve, the shut-off side of the change-over valve must be vented in order to relieve the pressure that still remains. Therefore, LESER recommends using a drain hole or a stop valve.

## Basics

According to the international regulatory requirements, the pressure loss in the inlet line to the safety valve must not drop below 3% of the differential pressure between the set pressure and the external back pressure, for large discharged mass flow rates. Pressure loss in the inlet line is understood to be the pressure difference between the pressure in the vessel to be secured and the pressure in front of the safety valve.

This also applies to a combination of change-over and safety valves. The change-over valve is considered to be part of the inlet line.

## Design of the LESER change-over valve

The outstanding flow behaviour (low pressure loss) of LESER change-over valves is achieved through the following factors:

- The orifice area on the inside of the LESER change-over valve is broadened. Through an enlargement of the cross-section, it is possible to reduce the pressure loss.
- Through the low redirection angle of 30°, considerably better flow is achieved than with the customary 90° angles.

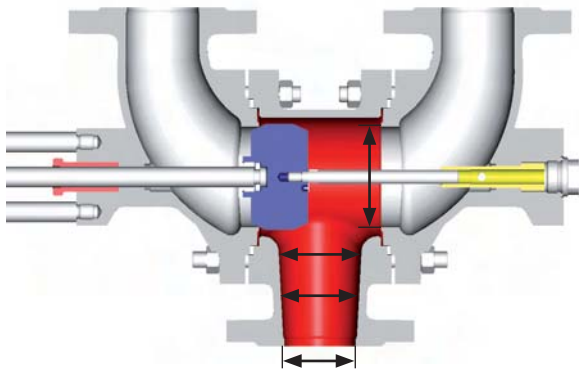

Enlarged orifice area in the seat area

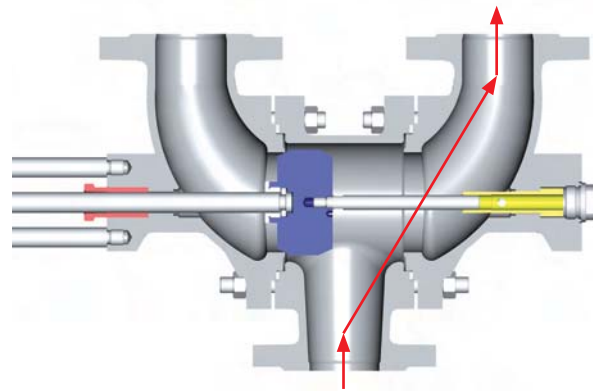

30° redirection angle

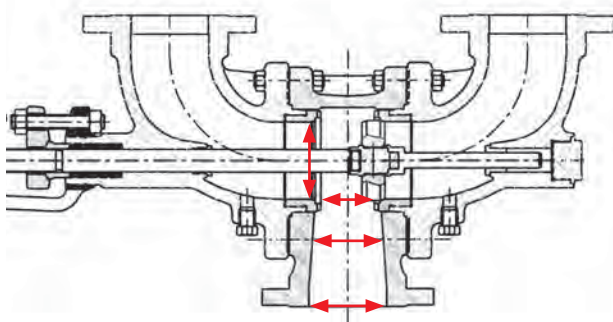

Orifice area – usual in the market

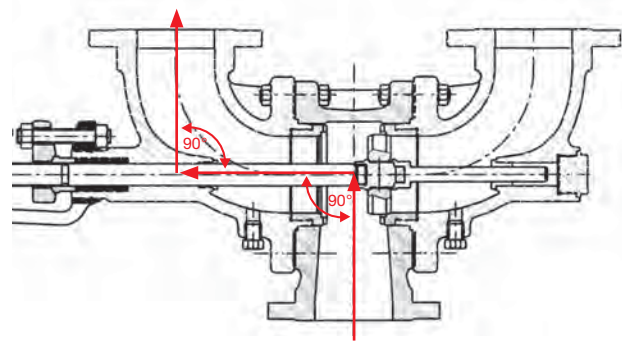

90° redirection angel – usual in the market

## What has to be done if the calculated pressure loss exceeds the 3% criterion?

Various measures are possible in order to keep the pressure loss in the inlet line to the safety valve below the 3% criterion.

- Avoid acute-angled inlet area from the vessel to the pipeline
- ensure the shortest possible inlet line to the safety valve
- increase the inlet line cross-section

If in spite of these measures, the 3% criterion is still exceeded, then the nominal diameter of the change-over valve should be increased and reducers installed. A reduction of up to three nominal diameters is possible.

## Resistance Coefficient

To be able to calculate the pressure loss, you need the pressure loss coefficient  $\zeta$  (Zeta). The pressure loss coefficient (i.e. the zeta value) is a dimensionless coefficient for the flow resistance of an object in a pipeline through which a medium is flowing. Basically, the pressure loss coefficient should be as low as possible.

The pressure loss coefficients of LESER change-over valves were determined individually on the LESER test bench. The values of the respective change-over valves for calculating the pressure loss can be found on pages 01/03 for Type 310 and 02/03 for Type 311 XXL. The basis of the calculation can be found on the following page.



## Calculation of the pressure loss

### Calculation of the pressure loss in the inlet line

LESER change-over valves are constructed such that an equal nominal diameter combination between the change-over valve and safety valve is possible. A calculation is necessary to exactly determine the change-over valve that is to be used.

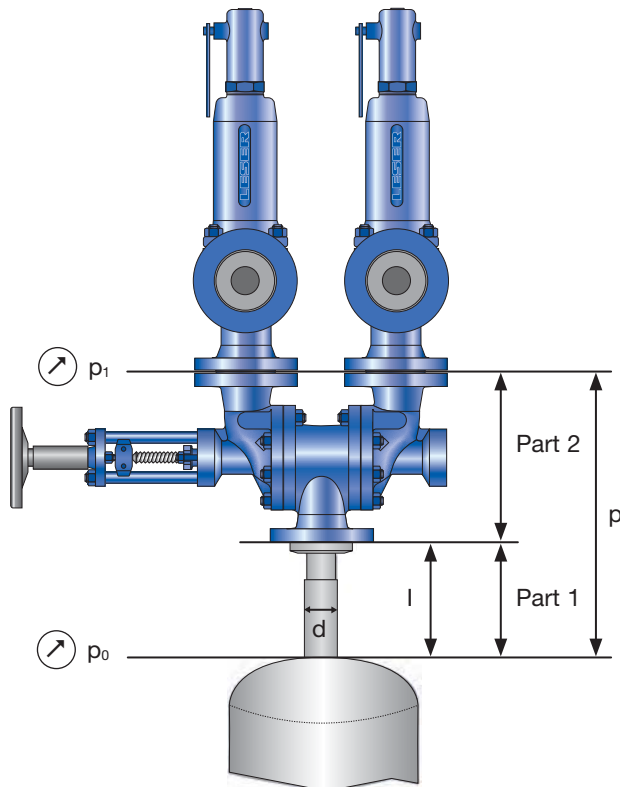

The pressure loss in the inlet line is calculated with the following formula:

$$\Delta p = \lambda \cdot \left( \frac{l}{d} + \sum \zeta \right) \cdot \frac{\rho}{2} \cdot w^2$$

General formula

this results in

$$\Delta p = \underbrace{\lambda \cdot \frac{l}{d} \cdot \frac{\rho}{2} \cdot w^2}_{\text{Part 1}} + \underbrace{\sum \zeta \cdot \frac{\rho}{2} \cdot w^2}_{\text{Part 2}}$$

Part 1: Describes the pipe friction in the inlet line to the safety valve.

Part 2: Describes the shape of the inlet line. Contains components such as elbows or change-over valves.

### Calculation of the pressure loss in the change-over valve

$$\Delta p_{wv} = \frac{\rho \cdot w^2}{2} \cdot \zeta$$

Examination of part 2

The losses in the change-over valve are expressed by the zeta value.

Formula symbols:

- $\Delta p$  Pressure loss in the change-over valve
- $\rho$  Density
- $\zeta$  Pressure loss coefficient (zeta value)
- $w$  Flow rate

### Calculation of the pressure loss with VALVESTAR®

An easy and user-friendly calculation of the pressure loss in the inlet line to the safety valve can be performed with the LESER design program VALVESTAR®. With the help of the program, it is possible to determine the pressure loss in the LESER change-over valve as well as that of other pipeline components. You can find VALVESTAR® at [www.valvestar.com](http://www.valvestar.com).

Step 1:

#### Choose before the configuration of the safety valve

- The calculation of the pressure loss in the inlet line should be calculated as part of the safety valve configuration.
- Possible choices between AD 2000-Merkblatt A2 and ISO 4126-9

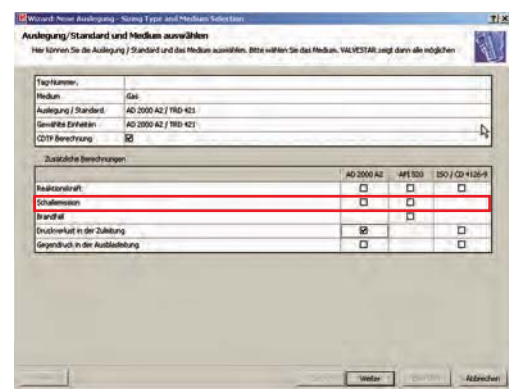

Step 2:

#### Design of the LESER safety valve

Step 3:

#### Calculation of the pressure loss in the change-over valve after choosing a safety valve

- choice of the line components at the inlet; here it is a change-over valve
- input of the zeta value (pressure loss coefficient)
- specification of the upstream line length

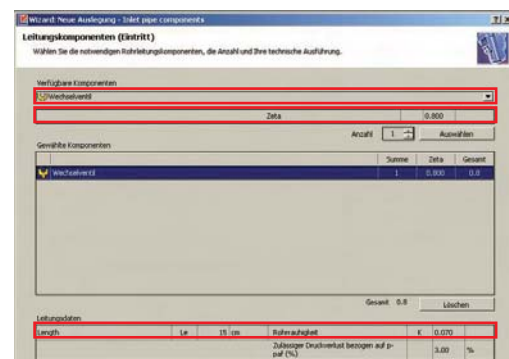

Through the input values, VALVESTAR® automatically calculates the pressure loss in the inlet line to the safety valve. VALVESTAR® also calculates the nominal diameters that are needed to achieve the 3% criterion, if necessary.

## How to order – order form inlet side

Please use the following forms to order change-over valves. This form is used both for the inlet-sided combination as well as for the lockable combination. It only applies to the inlet-sided change-over valve.

The forms for Type 310 and Type 311 XXL as well as the user instructions can be found on the LESER website [www.leser.com](http://www.leser.com); Area: Download; Category: Catalogues.

### Inlet-sided change-over valve

	<p><b>Assembly placement</b></p> <div style="text-align: center;"> <p><input type="checkbox"/> 1.0 = Standard</p> </div> <div style="text-align: center;"> <p><input type="checkbox"/> 1.1 = Variant 1</p> </div> <div style="text-align: center;"> <p><input type="checkbox"/> 1.2 = Variant 2</p> </div>	<p><b>Options</b></p> <div style="text-align: center;"> <p><input type="checkbox"/> Drain hole G<sup>1</sup>/<sub>2</sub></p> </div> <div style="text-align: center;"> <p><input type="checkbox"/> Final position switch</p> </div> <div style="text-align: center;"> <p><input type="checkbox"/> Flushing hole G<sup>1</sup>/<sub>2</sub></p> </div> <div style="text-align: center;"> <p><input type="checkbox"/> Bypass with non return valves</p> </div> <div style="text-align: center;"> <p><input type="checkbox"/> Stop valve for pressure relief</p> </div>
--	--	--

<b>Change-over valve LESER Art. no. 310</b>			<b>Quantity:</b>			<b>Pieces:</b>			<b>Date:</b>								
<input type="checkbox"/> DN 25	<input type="checkbox"/> DN 40	<input type="checkbox"/> DN 50	<input type="checkbox"/> DN 65	<input type="checkbox"/> DN 80	<input type="checkbox"/> DN 100	<input type="checkbox"/> DN 125	<input type="checkbox"/> DN 150	<input type="checkbox"/> DN 200	<input type="checkbox"/> NPS 1"	<input type="checkbox"/> NPS 1½"	<input type="checkbox"/> NPS 2"	<input type="checkbox"/> NPS 2½"	<input type="checkbox"/> NPS 3"	<input type="checkbox"/> NPS 4"	<input type="checkbox"/> NPS 5"	<input type="checkbox"/> NPS 6"	<input type="checkbox"/> NPS 8"
<input type="checkbox"/> 1.0619 / WCB		<input type="checkbox"/> 1.4408 / CF8M		<input type="checkbox"/> Others as per LWN 001.27													
<input type="checkbox"/> <b>Gland design</b>						<input type="checkbox"/> <b>Bellows design</b>											
<input type="checkbox"/> Hand wheel (standard)		<input type="checkbox"/> Locking device		<input type="checkbox"/> Hand wheel (standard)		<input type="checkbox"/> Locking device											
<input type="checkbox"/> Sprocket wheel		<input type="checkbox"/> Locking device		<input type="checkbox"/> Sprocket wheel		<input type="checkbox"/> Locking device											
<input type="checkbox"/> Chain of steel		<input type="checkbox"/> Chain of VA		<input type="checkbox"/> Chain of steel		<input type="checkbox"/> Chain of VA											
<b>Side 1, change-over valve body with connection to plant</b>																	
<input type="checkbox"/> PN 40	<input type="checkbox"/> PN 63	<input type="checkbox"/> PN 100	<input type="checkbox"/> PN 160	<input type="checkbox"/> CL300	<input type="checkbox"/> CL600	<input type="checkbox"/> CL900											
<input type="checkbox"/> Form B1		<input type="checkbox"/> Form B2		<input type="checkbox"/> Form RF		<input type="checkbox"/> Other:											
<b>Side 2, reduction to safety-valve nominal diameter – inlet</b>																	
<input type="checkbox"/> DN 25	<input type="checkbox"/> DN 40	<input type="checkbox"/> DN 50	<input type="checkbox"/> DN 65	<input type="checkbox"/> DN 80	<input type="checkbox"/> DN 100	<input type="checkbox"/> DN 125	<input type="checkbox"/> DN 150	<input type="checkbox"/> DN 200	<input type="checkbox"/> NPS 1"	<input type="checkbox"/> NPS 1½"	<input type="checkbox"/> NPS 2"	<input type="checkbox"/> NPS 2½"	<input type="checkbox"/> NPS 3"	<input type="checkbox"/> NPS 4"	<input type="checkbox"/> NPS 5"	<input type="checkbox"/> NPS 6"	<input type="checkbox"/> NPS 8"
<input type="checkbox"/> Form B1		<input type="checkbox"/> Form B2		<input type="checkbox"/> Form RF		<input type="checkbox"/> Other:											
<b>Side 2, change-over valve elbow A + B to safety valve – inlet</b>																	
<input type="checkbox"/> PN 40	<input type="checkbox"/> PN 63	<input type="checkbox"/> PN 100	<input type="checkbox"/> PN 160	<input type="checkbox"/> CL300	<input type="checkbox"/> CL600	<input type="checkbox"/> CL900											
<input type="checkbox"/> Form B1		<input type="checkbox"/> Form B2		<input type="checkbox"/> Form RF		<input type="checkbox"/> Other:											
<input type="checkbox"/> MTR as per DIN EN 10204 3.1 for body components						<input type="checkbox"/> MTR as per DIN EN 10204 3.1 for internal components disc, spindle, disc guide											
<b>Rating plate data</b>																	
<input type="checkbox"/> K <sub>vs</sub> value		<input type="checkbox"/> C <sub>v</sub> value		<input type="checkbox"/> ζ- Value													
<b>Additional change-over valve marking</b>																	
<input type="checkbox"/> No		<input type="checkbox"/> Yes		<input type="checkbox"/> Elbow A		<input type="checkbox"/> Elbow B		<input type="checkbox"/> Tag No.:									
<input type="checkbox"/> Text																	
<input type="checkbox"/> Additional information																	

## How to order – change-over valve outlet side

This form is used for the lockable combination. It only applies to the outlet-sided change-over valve.

### Outlet-sided change-over valve

	<b>Assembly placement</b>  <input type="checkbox"/> 1.0 = Standard	<b>Options</b>  <input type="checkbox"/> Drain hole G <sup>1</sup> / <sub>2</sub>
	 <input type="checkbox"/> 1.1 = Variant 1	 <input type="checkbox"/> Final position switch
	 <input type="checkbox"/> 1.2 = Variant 2	 <input type="checkbox"/> Flushing hole G <sup>1</sup> / <sub>2</sub>
		 <input type="checkbox"/> Bypass with non return valves
		 <input type="checkbox"/> Stop valve for pressure relief

<b>Change-over valve LESER Art. no. 310</b>			<b>Quantity:</b>			<b>Pieces:</b>			<b>Date:</b>								
<input type="checkbox"/> DN 25	<input type="checkbox"/> DN 40	<input type="checkbox"/> DN 50	<input type="checkbox"/> DN 65	<input type="checkbox"/> DN 80	<input type="checkbox"/> DN 100	<input type="checkbox"/> DN 125	<input type="checkbox"/> DN 150	<input type="checkbox"/> DN 200	<input type="checkbox"/> NPS 1"	<input type="checkbox"/> NPS 1 1/2"	<input type="checkbox"/> NPS 2"	<input type="checkbox"/> NPS 2 1/2"	<input type="checkbox"/> NPS 3"	<input type="checkbox"/> NPS 4"	<input type="checkbox"/> NPS 5"	<input type="checkbox"/> NPS 6"	<input type="checkbox"/> NPS 8"
<input type="checkbox"/> 1.0619 / WCB		<input type="checkbox"/> 1.4408 / CF8M		<input type="checkbox"/> Others as per LWN 001.27													
<b>Gland design</b>						<b>Bellows design</b>											
<input type="checkbox"/> Hand wheel (standard)		<input type="checkbox"/> Locking device		<input type="checkbox"/> Hand wheel (standard)		<input type="checkbox"/> Locking device											
<input type="checkbox"/> Sprocket wheel		<input type="checkbox"/> Locking device		<input type="checkbox"/> Sprocket wheel		<input type="checkbox"/> Locking device											
<input type="checkbox"/> Chain of steel		<input type="checkbox"/> Chain of VA		<input type="checkbox"/> Chain of steel		<input type="checkbox"/> Chain of VA											
<b>Side 1, change-over valve body with connection to plant</b>																	
<input type="checkbox"/> PN 40	<input type="checkbox"/> PN 63	<input type="checkbox"/> PN 100	<input type="checkbox"/> PN 160	<input type="checkbox"/> CL300	<input type="checkbox"/> CL600	<input type="checkbox"/> CL900											
<input type="checkbox"/> Form B1	<input type="checkbox"/> Form B2	<input type="checkbox"/> Form RF	<input type="checkbox"/> Other:														
<b>Side 2, reduction to safety-valve nominal diameter – outlet</b>																	
<input type="checkbox"/> DN 25	<input type="checkbox"/> DN 40	<input type="checkbox"/> DN 50	<input type="checkbox"/> DN 65	<input type="checkbox"/> DN 80	<input type="checkbox"/> DN 100	<input type="checkbox"/> DN 125	<input type="checkbox"/> DN 150	<input type="checkbox"/> DN 200	<input type="checkbox"/> NPS 1"	<input type="checkbox"/> NPS 1 1/2"	<input type="checkbox"/> NPS 2"	<input type="checkbox"/> NPS 2 1/2"	<input type="checkbox"/> NPS 3"	<input type="checkbox"/> NPS 4"	<input type="checkbox"/> NPS 5"	<input type="checkbox"/> NPS 6"	<input type="checkbox"/> NPS 8"
<input type="checkbox"/> Form B1	<input type="checkbox"/> Form B2	<input type="checkbox"/> Form RF	<input type="checkbox"/> Other:														
<b>Side 2, change-over valve elbow A + B to safety valve – outlet</b>																	
<input type="checkbox"/> PN 40	<input type="checkbox"/> PN 63	<input type="checkbox"/> PN 100	<input type="checkbox"/> PN 160	<input type="checkbox"/> CL300	<input type="checkbox"/> CL600	<input type="checkbox"/> CL900											
<input type="checkbox"/> Form B1	<input type="checkbox"/> Form B2	<input type="checkbox"/> Form RF	<input type="checkbox"/> Other:														
<input type="checkbox"/> MTR as per DIN EN 10204 3.1 for body components						<input type="checkbox"/> MTR as per DIN EN 10204 3.1 for internal components disc, spindle, disc guide											
<b>Rating plate data</b>																	
<input type="checkbox"/> K <sub>vs</sub> value		<input type="checkbox"/> C <sub>v</sub> value		<input type="checkbox"/> ζ- Value													
<b>Additional change-over valve marking</b>																	
<input type="checkbox"/> No		<input type="checkbox"/> Yes		<input type="checkbox"/> Elbow A		<input type="checkbox"/> Elbow B		<input type="checkbox"/> Tag No.:									
<input type="checkbox"/> Text																	
<input type="checkbox"/> Additional information																	

## Designs

Type 310

### Gland design

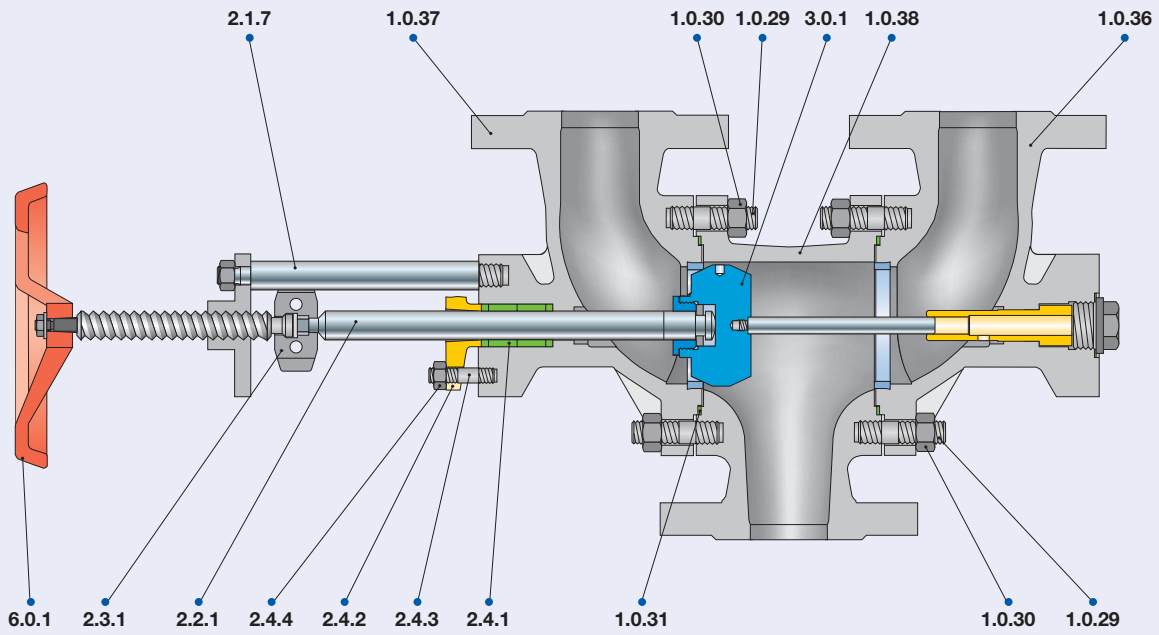

### Bellows design

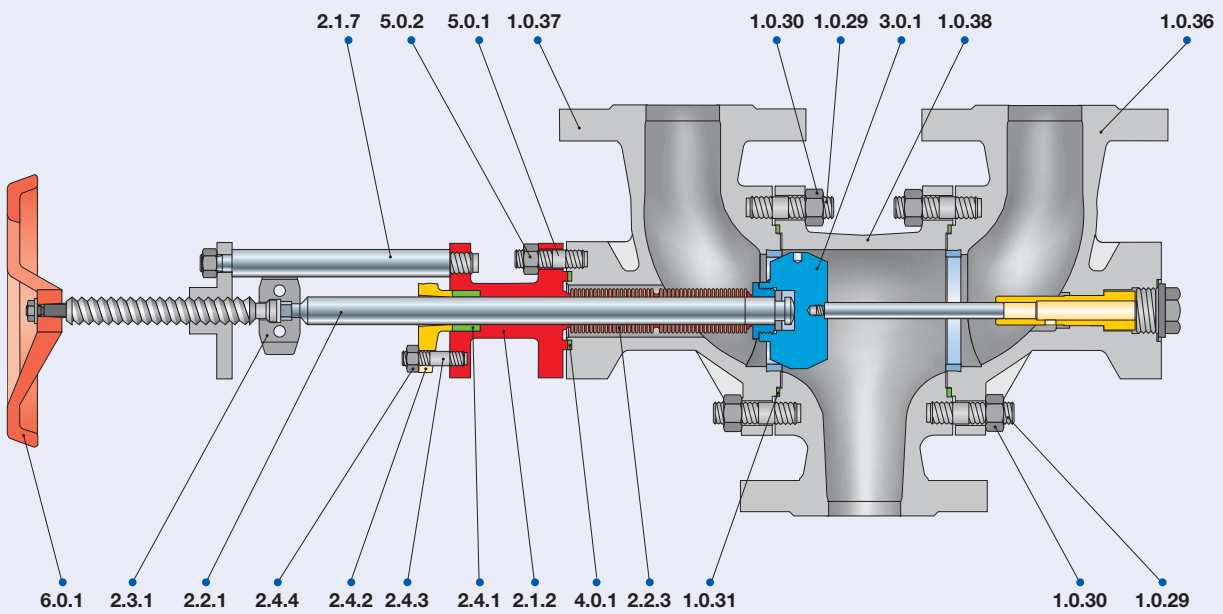

## Designs and materials

Materials		Type 3102	Type 3104
<b>General components</b>			
1.0.38	Body, centre section	1.0619 SA 216 WCB	1.4408 SA 351 CF8M
1.0.36	Elbow B	1.0619 SA 216 WCB	1.4408 SA 351 CF8M
1.0.37	Elbow A	1.0619 SA 216 WCB	1.4408 SA 351 CF8M
3.0.1	Disc	1.4021 / 1.0460 / 1.0619 1.0460 + 1.0619 hard-surface with 1.4009	1.4571 / 1.4408 stellited 316 Ti / CF8M stellited
2.2.1	Spindle	1.4122 / 1.4571 / 1.4301 Chrome steel / 316Ti / 304	1.4122 / 1.4571 Chrome steel / 316Ti
2.1.7	Column design	1.0037 Steel	1.4301 Steel
2.4.2	Stuffing box	1.0460 Steel	1.4408 CF8M
2.3.1	Position indicating device / turn lock	1.0420 Steel	1.4408 CF8M
6.0.1	Hand wheel	0.6020 Cast iron	0.6020 Cast iron
1.0.29	Stud	1.4301 Stainless steel	1.4301 Stainless steel
1.0.30	Nut	1.4301 Stainless steel	1.4301 Stainless steel
1.0.31	Body gasket	1.4571 / Graphite 316Ti / Graphite	1.4571 / Graphite 316Ti / Graphite
2.4.1	Packing gland	Graphite Graphite	Graphite Graphite
2.4.4	Nut	Steel, galvanized Steel, galvanized	1.4301 Stainless steel
2.4.3	Stud	Steel, galvanized Steel, galvanized	1.4301 Stainless steel
<b>Bellows design, specific</b>			
2.2.3	Bellows	1.4571 316Ti	1.4571 316Ti
2.4.1	Packing gland	Graphite Graphite	Graphite Graphite
2.1.2	Packing element	1.0460 / 1.0619 SA 105 / WCB	1.4571 / 1.4408 316 Ti / CF8M
4.0.1	Cover gasket	1.4571 / Graphite 316Ti / Graphite	1.4571 / Graphite 316Ti / Graphite
5.0.2	Nut	Steel, galvanized Steel, galvanized	1.4301 Stainless steel
5.0.1	Stud	Steel, galvanized Steel, galvanized	1.4301 Stainless steel

**Please note:**

- LESER reserves the right to make changes.
- LESER may use higher quality materials without giving prior notice.
- Each component can be replaced by another material according to the customer's specification.

## Article numbers and weights, pressure loss coefficients, and flow efficiency coefficient

### Article numbers

DN	25	40	50	65	80	100	125	150	200	250	300
Valve size	1"	1½"	2"	2½"	3"	4"	5"	6"	8"	10"	12"

#### Body material: 1.0619 (WCB)

#### PN 40 (CL150 – CL300)

Gland design	Art. no. 3102.	9320	9340	9350	9360	9370	9380	9390	9910	9920	9620	9630
Bellows design	Art. no. 3102.	9321	9341	9351	9361	9371	9381	9391	9911	9921	9621	9631

#### Body material: 1.4408 (CF8M)

#### PN 40 (CL150 – CL300)

Gland design	Art. no. 3104.	9420	9440	9450	9460	9470	9480	9490	9950	9960	9820	9830
Bellows design	Art. no. 3104.	9421	9441	93451	9461	9471	9481	9491	9951	9961	9821	9831

### Weights

Gland design	[kg]	25	46	48	99	99	151	156	323	667	830	950
Bellows design	[kg]	28	50	50	109	109	161	166	338	682	850	970
Gland design	[lbs]	56	102	107	220	220	336	347	718	1482	1830	2111
Bellows design	[lbs]	62	111	111	242	242	358	369	751	1516	1889	2156

### Pressure loss coefficients $\zeta$

Gland design	Hand wheel side [-]	0,60	0,60	0,70	0,83	0,83	0,79	0,84	0,81	0,84	0,99	0,84
	Opposite side [-]	0,60	0,70	0,90	0,90	0,90	0,94	0,98	0,89	0,92	0,96	0,76
Bellows design	Hand wheel side [-]	1,00	0,80	0,80	0,93	0,93	0,89	0,94	0,91	0,94	1,05	0,91
	Opposite side [-]	0,60	0,70	0,90	0,90	0,90	0,94	0,98	0,89	0,92	0,96	0,76

### Flow efficiency coefficient

kvs	[m³/h]	32	76	105	270	270	412	412	954	1667	1763	2478
Cv	[US-G.P.M.]	37	88	121	312	312	476	476	1103	1927	2046	2875

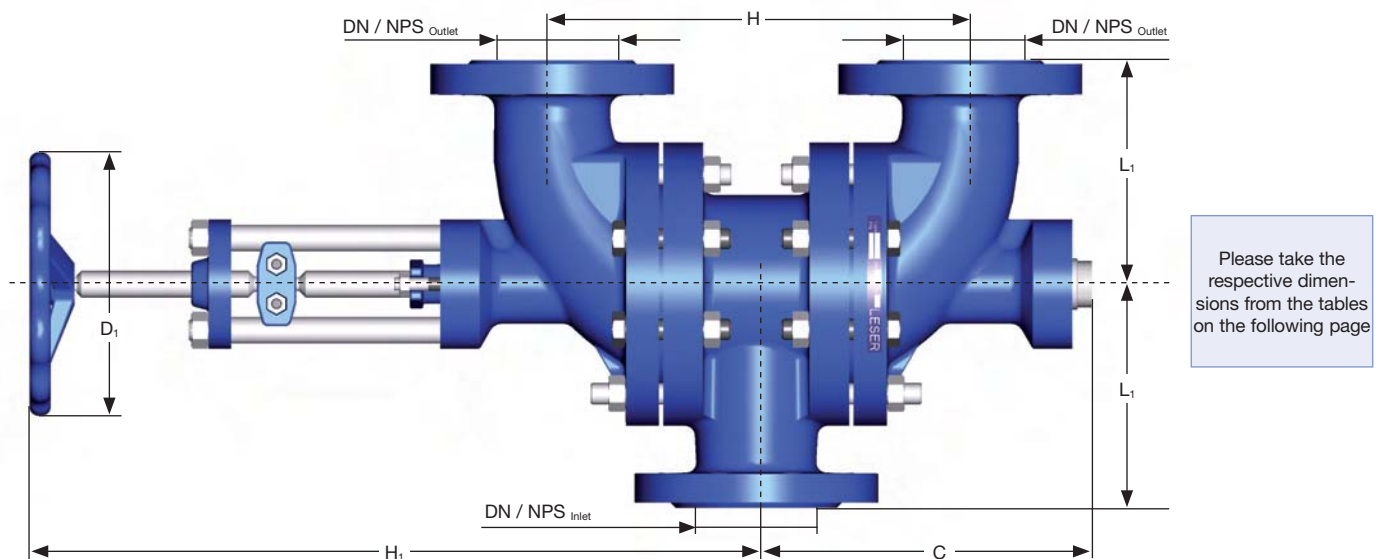

## Dimensions – Metric and US units

		Metric units											
		DN	25	40	50	65	80	100	125	150	200	250	300
		Valve size	1"	1½"	2"	2½"	3"	4"	5"	6"	8"	10"	12"
<b>≤ PN 40</b>													
	L <sub>1</sub>	[mm]	115	150	150	190		230	280	370	430	440	
	C	[mm]	160	240	240	300		360	480	630	730	790	
	D <sub>1</sub>	[mm]	150	200	200	300		300	400	500	600	600	
	H	[mm]	190	265	265	360		460	600	800	900	950	
	Gland design H <sub>1</sub>	[mm]	385	535	535	740		815	1090	1420	1670	1670	
	Bellows design H <sub>1</sub>	[mm]	470	617	617	910		990	1370	1690	1670	1670	
<b>PN 63</b>													
	L <sub>1</sub>	[mm]	175	150	210	190		230	330	370	A	A	
	C	[mm]	160	235	235	300		360	480	635	A	A	
	D <sub>1</sub>	[mm]	200	200	200	300		300	500	500	A	A	
	H	[mm]	190	265	265	360		460	620	800	A	A	
	Gland design H <sub>1</sub>	[mm]	385	535	535	740		815	1280	1445	A	A	
	Bellows design H <sub>1</sub>	[mm]	470	615	615	910		985	1485	1720	A	A	
<b>PN 100</b>													
	L <sub>1</sub>	[mm]	150	200	200	A		250	330	A	A	A	
	C	[mm]	160	270	270	A		360	480	A	A	A	
	D <sub>1</sub>	[mm]	200	300	300	A		400	500	A	A	A	
	H	[mm]	190	320	320	A		460	620	A	A	A	
	Gland design H <sub>1</sub>	[mm]	385	660	660	A		1020	1280	A	A	A	
	Bellows design H <sub>1</sub>	[mm]	655	930	930	A		1160	1485	A	A	A	
<b>PN 160</b>													
	L <sub>1</sub>	[mm]	150	200	200	A		300	A	A	A	A	
	C	[mm]	160	270	270	A		420	A	A	A	A	
	D <sub>1</sub>	[mm]	200	300	300	A		400	A	A	A	A	
	H	[mm]	190	320	320	A		540	A	A	A	A	
	Gland design H <sub>1</sub>	[mm]	385	660	660	A		1075	A	A	A	A	
	Bellows design H <sub>1</sub>	[mm]	655	930	930	A		1160	A	A	A	A	
		US units											
		DN	25	40	50	65	80	100	125	150	200	250	300
		Valve size	1"	1½"	2"	2½"	3"	4"	5"	6"	8"	10"	12"
<b>CL150 – CL300</b>													
	L <sub>1</sub>	[inch]	4 17/32	5 29/32	5 29/32	7 15/32		9 1/16	11 1/32	14 9/16	16 15/16	17 5/16	
	C	[inch]	6 5/16	9 1/4	9 1/4	11 13/16		14 3/16	19 3/32	25	27 15/16	29 23/32	
	D <sub>1</sub>	[inch]	7 7/8	7 7/8	7 7/8	11 13/16		11 13/16	15 3/4	19 11/16	23 5/8	23 5/8	
	H	[inch]	7 15/32	10 7/16	10 7/16	14 3/16		18 1/8	23 5/8	31 1/2	35 7/16	37 13/32	
	Gland design H <sub>1</sub>	[inch]	15 5/32	21 1/16	21 1/16	29 1/8		32 3/32	43 11/16	56 7/8	65 3/4	65 3/4	
	Bellows design H <sub>1</sub>	[inch]	18 1/2	24 7/32	24 7/32	35 13/16		38 25/32	54 23/32	67 23/32	65 3/4	65 3/4	
<b>CL600</b>													
	L <sub>1</sub>	[inch]	5 29/32	7 7/8	7 7/8	A		9 27/32	13	A	A	A	
	C	[inch]	6 5/16	10 5/8	10 5/8	A		14 3/16	18 29/32	A	A	A	
	D <sub>1</sub>	[inch]	7 7/8	11 13/16	11 13/16	A		15 3/4	19 11/16	A	A	A	
	H	[inch]	7 15/32	12 19/32	12 19/32	A		18 1/8	24 13/32	A	A	A	
	Gland design H <sub>1</sub>	[inch]	15 5/32	25 31/32	25 31/32	A		40 5/32	50 13/32	A	A	A	
	Bellows design H <sub>1</sub>	[inch]	25 25/32	36 5/8	36 5/8	A		45 21/32	58 15/32	A	A	A	
<b>CL900</b>													
	L <sub>1</sub>	[inch]	5 29/32	7 7/8	7 7/8	A		11 13/16	A	A	A	A	
	C	[inch]	6 5/16	10 5/8	10 5/8	A		16 17/32	A	A	A	A	
	D <sub>1</sub>	[inch]	7 7/8	11 13/16	11 13/16	A		15 3/4	A	A	A	A	
	H	[inch]	7 15/32	12 19/32	12 19/32	A		21 1/4	A	A	A	A	
	Gland design H <sub>1</sub>	[inch]	15 5/32	25 31/32	25 31/32	A		42 5/16	A	A	A	A	
	Bellows design H <sub>1</sub>	[inch]	25 25/32	36 5/8	36 5/8	A		45 21/32	A	A	A	A	

A = based on order; the dimensions are conveyed with the order confirmation

## Order information – spare parts

### Type 3102 – 1.0619 WCB

DN	25	40	50	65	80	100	125	150	200	250	300
Valve size	1"	1 1/2"	2"	2 1/2"	3"	4"	5"	6"	8"	10"	12"

#### Spindle seal with gland

Item No.	Spare part	Quantity	Pressure ratings	Option Code	Article number											
2.2.1/ 3.0.1	Spindle-Disc assembly	1	PN 40 / CL150 – CL300	–	3102.	9328	9348	9358	9368	9378	9388	9398	9918	9928	on request	
		1	PN 63	Y03												
		1	PN 100 / CL600	Y04 / Y42												
		1	PN 160 / CL900	Y17 / Y43												

#### Gasket set complete

Item No.	Spare part	Quantity	Article number											
1.0.31	Body gasket	2 pieces	3102.	9326	9346	9356	9366	9376	9386	9396	9916	9926	on request	
4.0.1	Cover gasket	1 piece as of DN 65												
2.4.1	Packing gland	1 pieces												

#### Spindle seal with stainless steel bellows

Item No.	Spare part	Quantity	Pressure ratings	Option Code	Article number											
2.2.1/ 3.0.1	Spindle-Disc assembly	1	PN 40 / CL150 – CL300	–	3102.	9329	9349	9359	9369	9379	9389	9398	9919	9929	on request	
		1	PN 63	Y03												
		1	PN 100 / CL600	Y04 / Y42												
		1	PN 160 / CL900	Y17 / Y43												

#### Gasket set complete

Item No.	Spare part	Quantity	Article number											
1.0.31	Body gasket	2 pieces	3102.	9327	9347	9357	9367	9377	9387	9397	9917	9927	on request	
4.0.1	Cover gasket	≤ DN 50: 1 piece; > DN 50: 2 pieces												
2.4.1	Packing gland	1 pieces												

### Spare parts

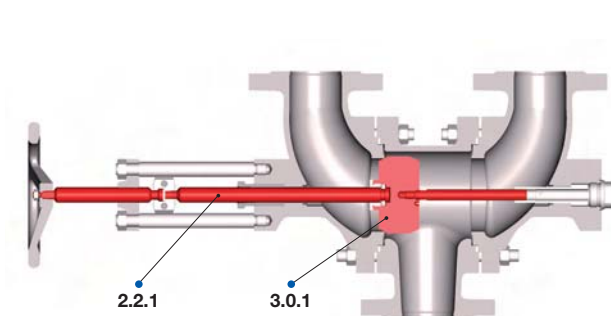

Spare parts, disc assembly

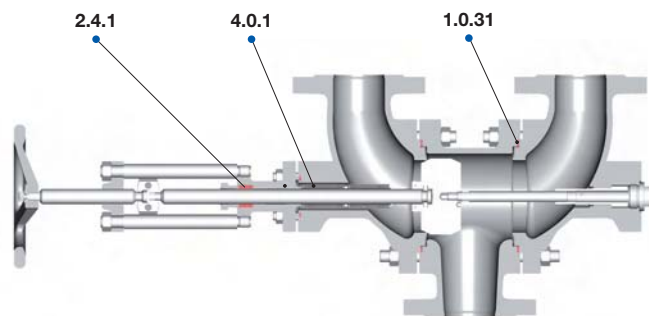

Spare parts, gasket set complete



## Order information – spare parts

### Type 3104 – 1.4408 (CF8M)

		DN													
		25	40	50	65	80	100	125	150	200	250	300			
		Valve size													
		1"	1 1/2"	2"	2 1/2"	3"	4"	5"	6"	8"	10"	12"			
<b>Spindle seal with gland</b>															
Item No.	Spare part	Quantity	Pressure ratings	Option Code	Article number										
2.2.1/ 3.0.1	Spindle-Disc assembly	1	PN 40 / CL150 – CL300	–	3104.	9428	9448	9458	9468	9478	9488	9498	9958	9968	on request
		1	PN 63	Y03											
		1	PN 100 / CL600	Y04 / Y42											
		1	PN 160 / CL900	Y17 / Y43											
<b>Gasket set complete</b>															
Item No.	Spare part	Quantity	Article number												
1.0.31	Body gasket	2 pieces	3104.	9426	9446	9456	9466	9476	9486	9496	9956	9966	on request		
4.0.1	Cover gasket	1 piece as of DN 65													
2.4.1	Packing gland	1 pieces													

<b>Spindle seal with stainless steel bellows</b>															
Item No.	Spare part	Quantity	Pressure ratings	Option Code	Article number										
2.2.1/ 3.0.1	Spindle-Disc assembly	1	PN 40 / CL150 – CL300	–	3104.	9429	9449	9459	9469	9479	9489	9498	9959	9969	on request
		1	PN 63	Y03											
		1	PN 100 / CL600	Y04 / Y42											
		1	PN 160 / CL900	Y17 / Y43											
<b>Gasket set complete</b>															
Item No.	Spare part	Quantity	Article number												
1.0.31	Body gasket	2 pieces	3104.	9427	9447	9457	9467	9477	9487	9497	9957	9967	on request		
4.0.1	Cover gasket	≤ DN 50: 1 piece; > DN 50: 2 pieces													
2.4.1	Packing gland	1 pieces													

### Link chain

		DN												
		25	40	50	65	80	100	125	150	200	250	300		
		NPS.												
		1"	1 1/2"	2"	2 1/2"	3"	4"	5"	6"	8"	10"	12"		
Item No.	Spare part	Number	Material	Article number										
6.0.18	Link chain	1 pieces	1.4401 / 316	3104.	9425	9445	9455	9465	9475	9485	9495	9955	9965	on request

The following spare parts recommendation is to be used as a guideline:

- 1 gasket set complete per change-over valve
- if bellows are used: 1 bellows per change-over valve

The actual need for replacing parts is dependent on several criteria such as:

- Operating temperature
- Environment
- Choice of material
- Medium

These operating conditions have an important effect on the service life of the change-over valve.

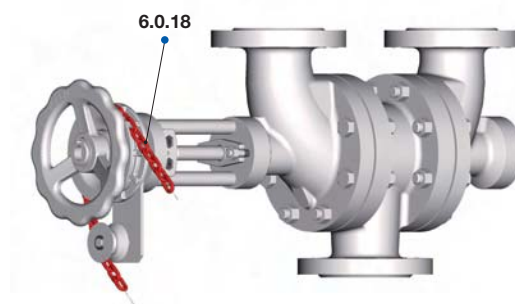

## Designs

### Gland design

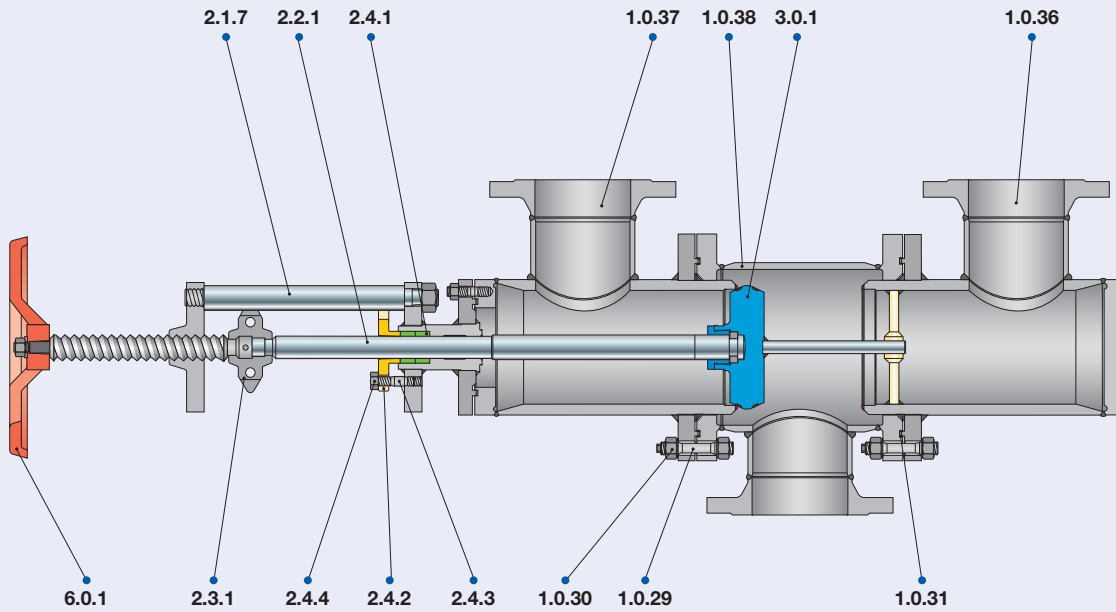

### Bellows design

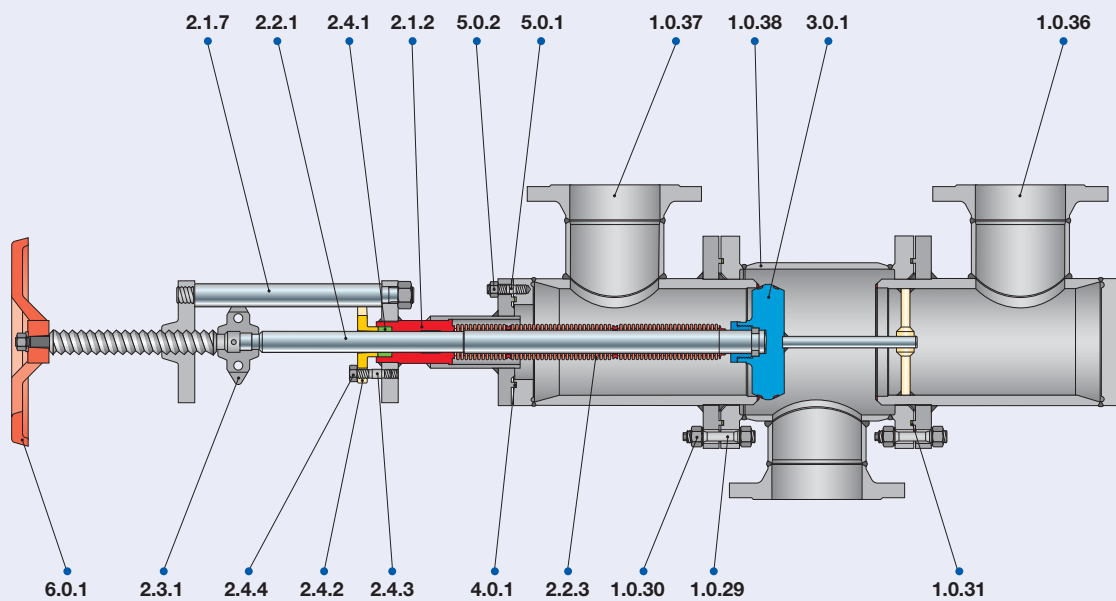

## Designs and materials

Materials			
Item.	Component	Type 3112	Type 3114
<b>General components</b>			
1.0.38	Body, centre section	1.0305 / 1.0425 A105	1.4571 316Ti
1.0.36	Elbow B	1.0305 / 1.0425 A105	1.4571 316Ti
1.0.37	Elbow A	1.0305 / 1.0425 A105	1.4571 316Ti
3.0.1	Disc	1.0425 / 1.4009 A105	1.4571 stellite CF8M stellite
2.2.1	Spindle	1.4122 / 1.4571 Chrome steel / 316Ti	1.4122 / 1.4571 Chrome steel / 316Ti
2.1.7	Column design	1.0037 Steel	1.4301 Stainless steel
2.4.2	Stuffing box	1.0037 Steel	1.4301 Stainless steel
2.3.1	Position indicating device / turn lock	1.0037 Steel	1.0037 galvanized Steel, galvanized
6.0.1	Hand wheel	Steel Steel	Steel Steel
1.0.29	Stud	1.4301 Stainless steel	1.4301 Stainless steel
1.0.30	Nut	1.4301 Stainless steel	1.4301 Stainless steel
1.0.31	Body gasket	1.4571 / Graphite 316Ti / Graphite	1.4571 / Graphite 316Ti / Graphite
2.4.1	Packing gland	Graphite Graphite	Graphite Graphite
2.4.4	Nut	Steel, galvanized Steel, galvanized	1.4301 Stainless steel
2.4.3	Stud	Steel, galvanized Steel, galvanized	1.4301 Stainless steel
<b>Bellows design, specific</b>			
2.2.3	Bellows	1.4571 316Ti	1.4301 Stainless steel
2.4.1	Packing gland	Graphite Graphite	Graphite Graphite
2.1.2	Packing element	1.0460 / 1.0619 SA 105 / WCB	1.4571 / 1.4408 316Ti / CF8M
4.0.1	Cover gasket	1.4571 / Graphite 316Ti / Graphite	1.4571 / Graphite 316Ti / Graphite
5.0.2	Nut	Steel, galvanized Steel, galvanized	1.4301 Stainless steel
5.0.1	Stud	Steel, galvanized Steel, galvanized	1.4301 Stainless steel

**Please note:**

- LESER reserves the right to make changes.
- LESER may use higher quality materials without giving prior notice.
- Each component can be replaced by another material according to the customer's specification.
- Data applies to Type 311 XXL DN 400. DN 500 on request

## Article numbers, dimensions and weights, pressure loss coefficients, and flow efficiency coefficient

### Article numbers

	<b>DN</b>	400	500
	<b>Valve size</b>	16"	20"
<b>Body material: 1.0305 / 1.0425 (A105)</b>			
<b>PN 25 (CL150)</b>			
<b>Gland design</b>	Art. no. <b>3112.</b>	<b>9640</b>	<b>9650</b>
<b>Bellows design</b>	Art. no. <b>3112.</b>	<b>9641</b>	<b>9651</b>
<b>Body material: 1.4571 (316Ti)</b>			
<b>PN 25 (CL150)</b>			
<b>Gland design</b>	Art. no. <b>3114.</b>	<b>9840</b>	<b>9850</b>
<b>Bellows design</b>	Art. no. <b>3114.</b>	<b>9841</b>	<b>9851</b>
<b>Weights</b>			
<b>Gland design</b>	[kg]	450	-
<b>Bellows design</b>	[kg]	470	-
<b>Gland design</b>	[lbs]	900	-
<b>Bellows design</b>	[lbs]	1044	-
<b>Pressure loss coefficients <math>\zeta</math></b>			
<b>Gland design</b>	[-]	2,00	based on order
<b>Bellows design</b>	[-]	2,00	based on order
<b>Flow efficiency coefficient</b>			
<b>kvs</b>	[m <sup>3</sup> /h]	4514	based on order
<b>Cv</b>	[US-G.P.M]	5236	based on order

### Dimensions

	<b>DN</b>	400	500
	<b>Valve size</b>	16"	20"
<b>Metric units PN 40</b>			
	<b>L<sub>1</sub></b> [mm]	500	Order-based manufacture
	<b>C</b> [mm]	960	
	<b>D<sub>1</sub></b> [mm]	600	
	<b>H</b> [mm]	1250	
<b>Gland design</b>	<b>H<sub>1</sub></b> [mm]	1600	
<b>Bellows design</b>	<b>H<sub>1</sub></b> [mm]	1600	
<b>US units CL 150 – CL300</b>			
	<b>L<sub>1</sub></b> [inch]	19 <sup>2</sup> / <sub>3</sub>	Order-based manufacture
	<b>C</b> [inch]	37 <sup>3</sup> / <sub>4</sub>	
	<b>D<sub>1</sub></b> [inch]	23 <sup>1</sup> / <sub>2</sub>	
	<b>H</b> [inch]	49 <sup>1</sup> / <sub>4</sub>	
<b>Gland design</b>	<b>H<sub>1</sub></b> [inch]	63	
<b>Bellows design</b>	<b>H<sub>1</sub></b> [inch]	63	

Higher flange pressure ratings will be manufactured based on the order. Please inquire about the respective dimensions at sales@leser.com.

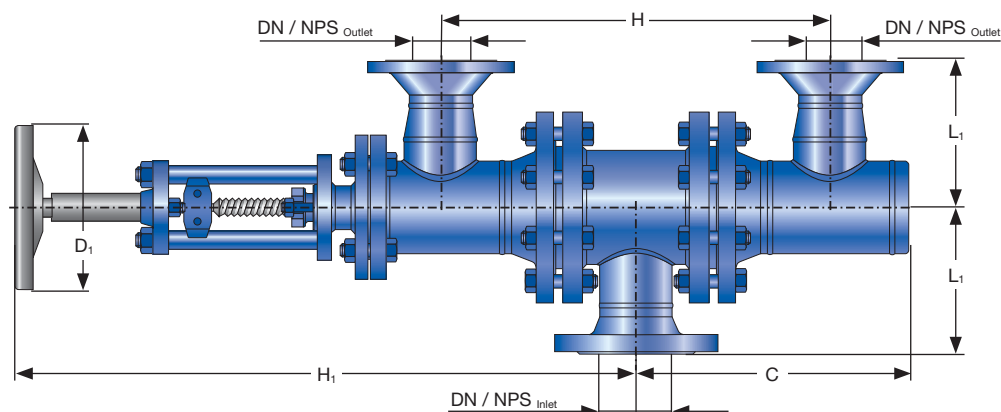

## Order information – spare parts

### Type 3112 XXL

1.0305 / 1.0460 (A106B / A105)

<b>DN</b>	<b>400</b>	<b>500</b>
<b>Valve size</b>	<b>16"</b>	<b>20"</b>

#### Spindle seal with gland

Item No.	Spare part	Quantity	Pressure ratings	Opt. Code	Article number		
2.2./ 3.0.1	Spindle-Disc assembly	1	PN 40 / CL150 – CL300	–	3112.	9648	9658
		1	PN 63	Y03			
		1	PN 100 / CL600	Y04 / Y42			
		1	PN 160 / CL900	Y17 / Y43			

#### Gasket set complete

Item No.	Spare part	Quantity	Article number		
1.0.31	Body gasket	2 pieces	3112.	9646	9656
4.0.1	Cover gasket	≤ DN 50: 1 piece; > DN 50: 2 pieces			
3.0.1	Packing gland	1 pieces			

#### Spindle seal with stainless steel bellows

Item No.	Spare part	Quantity	Pressure ratings	Opt. Code	Article number		
2.2./ 3.0.1	Spindle-Disc assembly	1	PN 40 / CL150 – CL300	–	3112.	9649	9659
		1	PN 63	Y03			
		1	PN 100 / CL600	Y04 / Y42			
		1	PN 160 / CL900	Y17 / Y43			

#### Gasket set complete

Item No.	Spare part	Quantity	Article number		
1.0.31	Body gasket	2 pieces	3112.	9647	9657
4.0.1	Cover gasket	≤ DN 50: 1 piece; > DN 50: 2 pieces			
3.0.1	Packing gland	1 pieces			

### Type 3114 XXL

1.4571 (316Ti)

<b>DN</b>	<b>400</b>	<b>500</b>
<b>Valve size</b>	<b>16"</b>	<b>20"</b>

#### Spindle seal with gland

Item No.	Spare part	Quantity	Pressure ratings	Opt. Code	Article number		
2.2./ 3.0.1	Spindle-Disc assembly	1	PN 40 / CL150 – CL300	–	3114.	9848	9858
		1	PN 63	Y03			
		1	PN 100 / CL600	Y04 / Y42			
		1	PN 160 / CL900	Y17 / Y43			

#### Gasket set complete

Item No.	Spare part	Quantity	Article number		
1.0.31	Body gasket	2 pieces	3114.	9846	9856
4.0.1	Cover gasket	≤ DN 50: 1 piece; > DN 50: 2 pieces			
2.4.1	Packing gland	1 pieces			

#### Spindle seal with stainless steel bellows

Item No.	Spare part	Quantity	Pressure ratings	Opt. Code	Article number		
2.2./ 3.0.1	Spindle-Disc assembly	1	PN 40 / CL150 – CL300	–	3114.	9849	9859
		1	PN 63	Y03			
		1	PN 100 / CL600	Y04 / Y42			
		1	PN 160 / CL900	Y17 / Y43			

#### Gasket set complete

Item No.	Spare part	Quantity	Article number		
1.0.31	Body gasket	2 pieces	3114.	9847	9857
4.0.1	Cover gasket	≤ DN 50: 1 piece; > DN 50: 2 pieces			
2.4.1	Packing gland	1 pieces			

#### Link chain

Item No.	Spare part	Material	Article number		
6.0.18	Link chain	1.4401 / 316	3114.	9845	9855

The following spare parts recommendation is to be used as a guideline:  
 – 1 gasket set complete per change-over valve  
 – if bellows are used: 1 bellows per change-over valve

The actual need for replacing parts is dependent on several criteria such as:  
 – Operating temperature  
 – Environment  
 – Choice of material  
 – Medium

# Change-over valve combination

## Combination with safety valves

### Inlet side combination

There is an inlet sided combination if a change-over valve is installed at the inlet of the safety valve. No change-over valve is installed at that outlet of the safety valve.

This combination is used for applications if

- the safety valves blows into the atmosphere.

- each safety valve is connected to a separate blowdown system.
- each safety valve is connected separately to a common blowdown system. Here, you must make sure that no medium leaks out of the outlet line of the removed safety valve.

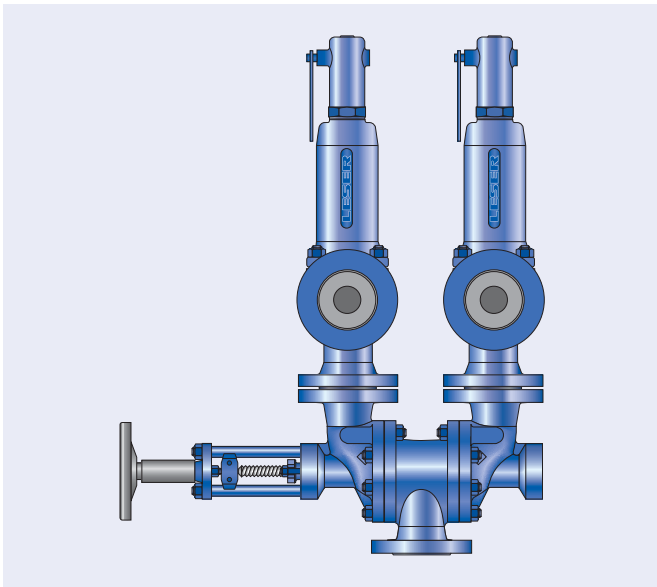

Front view: Inlet sided combination

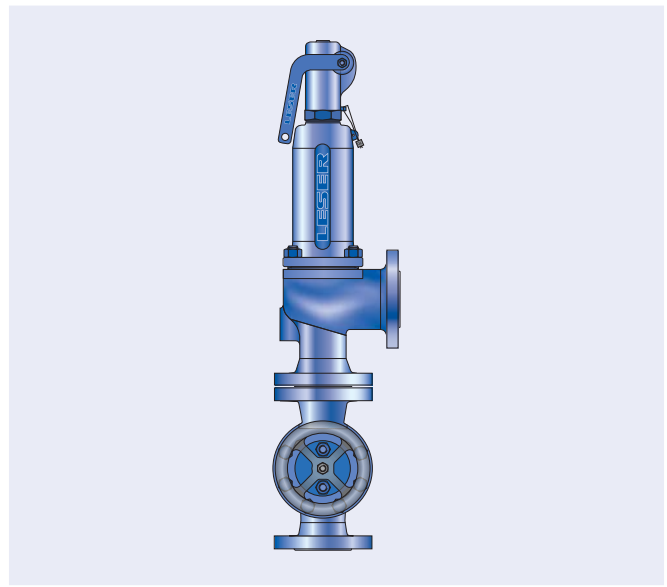

Side view: Inlet sided combination

The fitting dimensions of the inlet-sided combination can be found in the Technical Information category of the download area of the LESER website [www.leser.com](http://www.leser.com).

## Combination with safety valves

### Lockable combination

There is a lockable combination if a change-over valve is installed both at the inlet as well as the outlet of the safety valve. The change-over valves must have the same nominal diameter so that assembly is possible due to the H dimension. The size of the change-over valve is orientated around the change-over valve installed at the outlet.

The two change-over valves are setup the same and connected through the sprocket wheel and chain. That way, it is guaranteed that the stand-by safety valve is closed both at the inlet as well as the outlet.

Please note that each hand wheel must be retightened separately when closing in order to compensate for the play in the chain and hand wheel. Only that way is it guaranteed that the side to be shut-off is tightly closed both at the inlet as well as the outlet of the safety valve.

The combination is used for applications if the safety valves are connected to a common blowdown system.

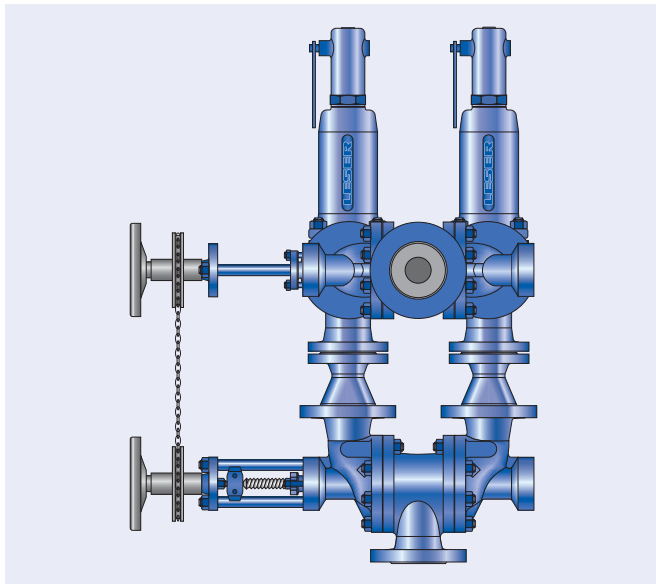

Front view: Lockable combination

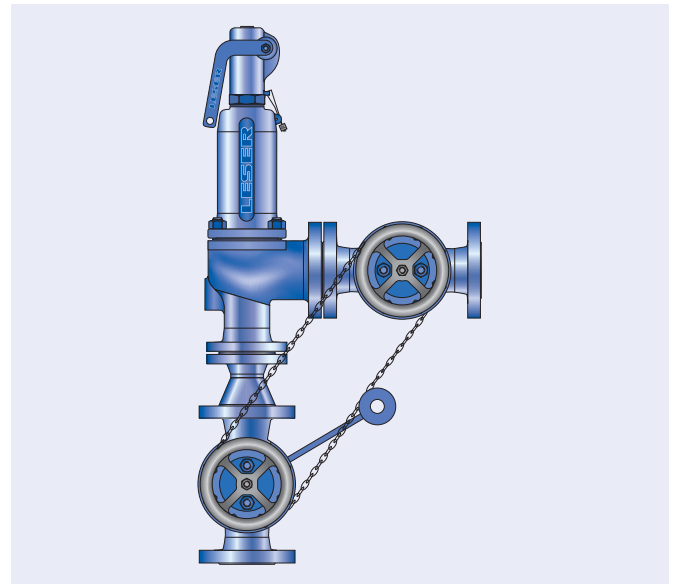

Side view: Lockable combination

The fitting dimensions of the lockable combination can be found in the Technical Information category of the download area of the LESER website [www.leser.com](http://www.leser.com).

### Change-over valve – sprocket wheel

Materials			
Item.	Component	Type 3102	Type 3104
6.0.1	Hand wheel	0.6020 Cast iron	0.6020 Cast iron
6.0.6	Sprocket wheel	0.6020 galv. / 0.6025 galv. Cast iron	0.6020 galv. / 0.6025 galv. Cast iron
6.0.11	Small roller	1.4301 Stainless steel	1.4301 Stainless steel
6.0.18	Chain	1.4401 316	1.4401 316

When ordering a lockable combination, a change-over valve with a sprocket wheel (Option Code Y35) is ordered and a change-over valve with a sprocket wheel and chain (Option Code Y36).

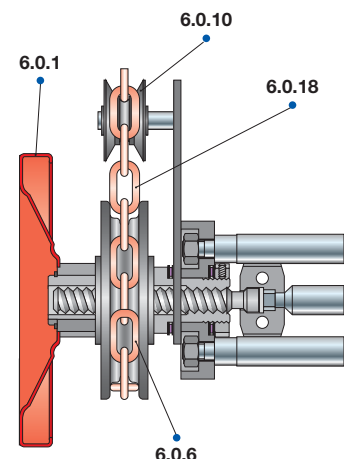

## Application and materials

### Application

All LESER safety valve product groups have a larger nominal diameter at the outlet than at the inlet (Exception: Modulate Action). The change-over valves of the lockable combination must have the same nominal diameter.

Therefore, if necessary, the outlet nominal diameter of the inlet-side of the change-over valve must be reduced to the inlet nominal diameter of the safety valves, which can be achieved through reducers. Due to the different nominal diameter combinations of the safety valves, a reduction of 1, 2, or 3 nominal diameters may be necessary.

	Inlet-side change-over valve	Outlet-side change-over valve
Safety valve $DN_{Inlet} = DN_{Outlet}$	$DN_{WV} = DN_{Inlet, SV}$	$DN_{WV} = DN_{Outlet, SV}$
Safety valve $DN_{Inlet} < DN_{Outlet}$	$DN_{WV} > DN_{Inlet, SV}$ → Reduction to $DN_{Inlet, SV}$ necessary	$DN_{WV} = DN_{Outlet, SV}$

### Installation of reducers

**Type 310:** The reducers are pre-welded on side 2 of the inlet side of the change-over valve.

**Type 311 XXL:** No reducers are necessary because the adaptation is provided by the welded structure.

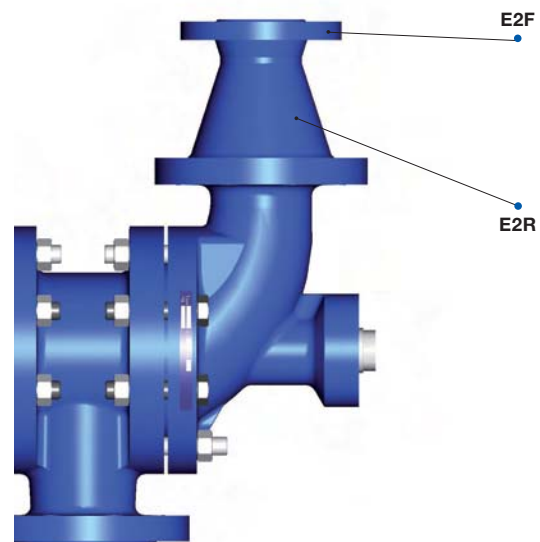

### Materials

Item.	Component	Type 3102	Type 3104
E2F	Reducer flange	1.0460 SA 105	1.4571 316Ti
E2R	Reducer	1.0305 Steel	1.4571 316Ti



## Dimensions and weights

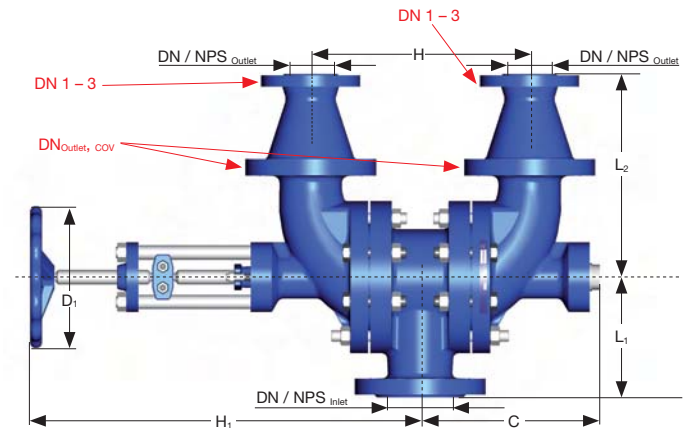

Dimension  $L_2$  represents the half height of the change-over valve plus the height of the reducer ( $L_2 = L_1 + \text{reducer height}$ ).

The other dimensions can be found on pages 01/04 for Type 310 and 02/03 for Type 311 XXL.

Nominal diameter outlet side change-over valve												
Size	DN <sub>Outlet, cov</sub>	DN	40	50	65	80	100	125	150	200	250	300
		NPS	1/2"	2"	2 1/2"	3"	4"	5"	6"	8"	10"	12"
Reduction by one nominal diameter												
DN <sub>1</sub>	Nominal diameter after reduction	DN	32	40	50	65	80	100	125	150	200	250
		NPS	1 1/4"	1 1/2"	1"	2 1/2"	3"	4"	5"	6"	8"	10"
L <sub>2</sub>	PN 40	[mm]	250	265	325	325	380	415	485	580	610	745
		[inch]	9 3/4	10 1/2	12 5/8	12 3/4	14 15/16	16 3/8	19 1/8	22 3/4	24 1/64	29 1/4
	PN 63	[mm]	255	A	340	340	395	430	555	A	A	A
		[inch]	10 1/16	A	13 3/8	13 3/8	15 1/2	16 7/8	21 7/8	A	A	A
	PN 100	[mm]	315	200	A	A	290	A	570	A	A	A
		[inch]	12 3/8	7 7/8	A	A	11 1/2	A	22 1/2	A	A	A
	PN 160	[mm]	315	200	A	A	380	A	A	A	A	A
		[inch]	12 2/4	7 7/8	A	A	14 15/16	A	A	A	A	A
Reduction by two nominal diameters												
DN <sub>2</sub>	Nominal diameter after reduction	DN	25	32	40	50	65	80	100	125	150	200
		NPS	1"	1 1/4"	1 1/2"	2"	2 1/2"	3"	4"	5"	6"	8"
L <sub>2</sub>	PN 40	[mm]	250	265	325	325	380	415	485	580	610	730
		[inch]	9 7/8	10 1/2	12 3/4	12 3/4	14 15/16	16 5/16	19 1/8	22 3/4	24 1/64	28 3/4
	PN 63	[mm]	255	330	340	340	395	430	540	A	A	A
		[inch]	10 1/16	13	13 3/8	13 3/8	15 1/8	16 7/8	21 3/8	A	A	A
	PN 100	[mm]	315	330	A	A	380	A	550	A	A	A
		[inch]	12 3/8	13	A	A	14 15/16	A	21 5/8	A	A	A
	PN 160	[mm]	315	330	A	A	A	A	550	A	A	A
		[inch]	12 9/16	13	A	A	A	A	21 5/8	A	A	A
Reduction by three nominal diameters												
DN <sub>3</sub>	Nominal diameter after reduction	DN	-	25	32	40	50	65	80	100	125	150
		NPS	-	1"	1 1/4"	1 1/2"	2"	2 1/2"	3"	4"	5"	6"
L <sub>2</sub>	PN 40	[mm]	-	265	A	325	A	A	470	580	A	A
		[inch]	-	10 1/2	A	12 3/4	A	A	18 1/2	22 3/4	A	A
	PN 63	[mm]	-	A	A	340	400	A	540	A	A	A
		[inch]	-	A	A	13 3/8	15 3/4	A	21 1/4	A	A	A
	PN 100	[mm]	-	A	A	A	A	A	550	A	A	A
		[inch]	-	A	A	A	A	A	21 1/2	A	A	A
	PN 160	[mm]	-	330	A	A	A	A	A	A	A	A
		[inch]	-	13	A	A	A	A	A	A	A	A

A = based on order; the dimensions are conveyed with the order confirmation  
 - = not possible

## Weights of change-over valves with reducers

Metric units												
Gland design	[kg]	53	57	96	99	151	156	323	667	830	950	
Bellows design	[kg]	57	59	106	109	161	166	338	682	850	970	
US units												
Gland design	[lbs]	118	127	213	220	336	347	1510	1874	2138	2138	
Bellows design	[lbs]	127	130	236	242	358	369	751	1516	1889	2156	



## Flange drillings and facings

Flange drillings																									
DN	25	40	50	65	80	100	125	150	200	250	300	25	40	50	65	80	100	125	150	200	250	300			
NPS	1"	1 1/2"	2"	2 1/2"	3"	4"	5"	6"	8"	10"	12"	1"	1 1/2"	2"	2 1/2"	3"	4"	5"	6"	8"	10"	12"			
Option Code – Inlet												Option Code – Outlet													
PN 10	Y96	Y96	Y96	Y96	Y96	Y96	Y96	Y96	Y96	Y96	Y96	Y97	Y97	Y97	Y97	Y97	Y97	Y97	Y97	Y97	Y97	Y97			
PN 16	Y13	Y13	Y13	Y13	Y13	Y13	Y13	Y13	Y13	Y13	Y13	Y23	Y23	Y23	Y23	Y23	Y23	Y23	Y23	Y23	Y23	Y23			
PN 25	Y01	Y01	Y01	Y01	Y01	Y01	Y01	Y01	*	*	*	Y05	Y05	Y05	Y05	Y05	Y05	Y05	Y05	*	*	*			
PN 40	*	*	*	*	*	*	*	*	Y02	Y02	Y02	*	*	*	*	*	*	*	*	Y06	Y06	Y06			
PN 63	Y03	Y03	Y03	Y03	Y03	Y03	Y03	Y03	Y03	Y03	Y03	Y07	Y07	Y07	Y07	Y07	Y07	Y07	Y07	Y07	Y07	Y07			
PN 100	Y04	Y04	Y04	Y04	Y04	Y04	Y04	Y04	Y04	Y04	Y04	Y08	Y08	Y08	Y08	Y08	Y08	Y08	Y08	Y08	Y08	Y08			
PN 160	Y17	Y17	Y17	Y17	Y17	Y17	Y17	Y17	Y17	Y17	Y17	Y27	Y27	Y27	Y27	Y27	Y27	Y27	Y27	Y27	Y27	Y27			
CL150	Y14	Y14	Y14	Y14	Y14	Y14	Y14	Y14	Y14	Y14	Y14	Y24	Y24	Y24	Y24	Y24	Y24	Y24	Y24	Y24	Y24	Y24			
CL300	Y16	Y16	Y16	Y16	Y16	Y16	Y16	Y16	Y16	Y16	Y16	Y26	Y26	Y26	Y26	Y26	Y26	Y26	Y26	Y26	Y26	Y26			
CL600	Y42	Y42	Y42	Y42	Y42	Y42	Y42	Y42	Y42	Y42	Y42	Y42	Y42	Y42	Y42	Y42	Y42	Y42	Y42	Y42	Y42	Y42			
CL900	Y43	Y43	Y43	Y43	Y43	Y43	Y43	Y43	Y43	Y43	Y43	Y43	Y43	Y43	Y43	Y43	Y43	Y43	Y43	Y43	Y43	Y43			



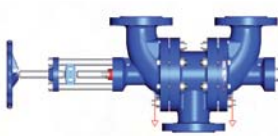

\* = Standard

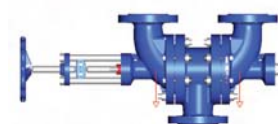
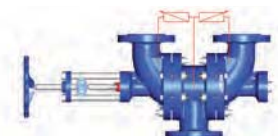
Flange facings		
DIN EN 1092		
(also see LWN 313.40)		
Raised face	Inlet	Outlet
	Option Code	Option Code
Form B1	*	*
Form B2	Y09	Y21
Tongue, Form C	Y10	Y22
Groove, Form D	Y11	Y25
Male, Form E	Y12	Y28
Female, Form F	Y15	Y29
O-ring Male, Form G	Y18	Y30
O-ring Female, Form H	Y19	Y37
ASME B16.5	Inlet	Outlet
	Option Code	Option Code
Flat Face, FF	Y81	Y82
Raised Face, RF	Y83	Y84
Ring Joint Face, RTJ	Y85	Y86
Small Tongue Face, STF	Y65	Y73
Small Groove Face, SGF	Y66	Y74
Long Tongue Face, LTF	Y67	Y75
Long Groove Face, LGF	Y68	Y76
Small Male Face, SMF	Y69	Y77
Small Female Face, SFF	Y70	Y78
Long Male Face, LMF	Y71	Y79
Long Female Face, LFF	Y72	Y80

## Options

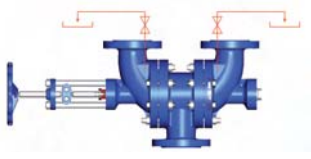
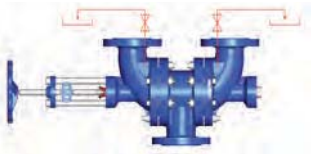
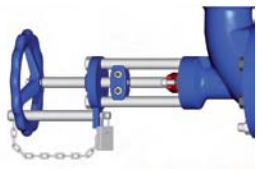
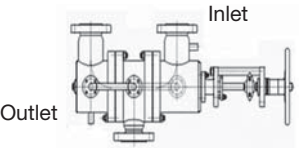
Option	Option Code	Description
 <p><b>Drain hole</b></p>	<p>Y99 (<math>\leq</math> DN 200) G 1/4, as per DIN 3852 – Form X</p> <p>Y49 (<math>\geq</math> DN 250) G 1/2, as per DIN 3852 – Form X</p>	<p><b>Application</b> The drain hole is used for draining the change-over valve. Especially for securing steam, the condensate can be removed through the holes.</p> <p><b>Technical design</b> Placement of a drill hole on the bottom of the flanged-end bend. Available for DN 25 to DN 500 / NPS 1" to 20"</p>
 <p><b>Final position switch</b></p>	Y98	<p><b>Application</b> The final position switch is a device to show the closed side of the change-over valve. In addition, visual and audible alarms or even process controls can be connected.</p> <p><b>Technical design</b> Installation of induction switches on the column structure Available for DN 25 to DN 500 / NPS 1" to 20"</p>
 <p><b>Flushing hole</b></p>	<p>Y38 G 1/2, as per DIN 3852 – Form X</p>	<p><b>Application</b> Flushing hole is used for automatic cleaning processes like CIP or to avoid build-ups. In addition, the connection can be used to monitor the operating pressure.</p> <p><b>Technical design</b> Placement of the connections in the centre of the elbow. Available for DN 25 to DN 500 / NPS 1" to 20"</p>
 <p><b>Bypass with non return valves</b></p>	Y39	<p><b>Application</b> The bypass with non return valves is used for pressure relief when moving the cone to the side to be shut-off. The closed side is relieved after the change-over.</p> <p><b>Technical design</b> Connection of the non return valves in the centre of the elbow. Available for DN 25 to DN 500 / NPS 1" to 20"</p>

## Options

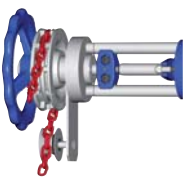
Option	Option Code	Description
<p><b>Needle valve</b></p> 	Z51	<p><b>Application</b> The needle valve is used to relieve the gap to the safety valve on the process side. Caution: The pressure in the gap must be relieved before maintenance begins.</p> <p><b>Technical design</b> Installation of a needle valve on the bottom of the flanged-end bend. Available for DN 25 to DN 500 / NPS 1" to 20"</p>
<p><b>Stop valve for pressure relief</b></p> 	Y46	<p><b>Application</b> The stop valve is used to relieve the pressure in the gap to the safety valve on the process side. Caution: The pressure in the gap must be relieved before maintenance begins.</p> <p><b>Technical design</b> Installation of a shut-off valve on the bottom of the flanged-end bend. Available for DN 25 to DN 500 / NPS 1" to 20"</p>
<p><b>Locking device for the hand wheel</b></p> 	Z50	<p><b>Application</b> The locking device is used to secure the hand wheel against unauthorised adjustment.</p> <p><b>Technical design</b> Placement of bolts, link chains and lock on hand wheel and column structure Available for DN 25 to DN 200 / NPS 1" to 8" As of nominal diameter DN 250 to DN 500, a bevel gear drive is necessary to move the cone. It is available with a locking device.</p>
<p><b>Heating jacket</b></p> 	<p>H32 Flange connection DN25 / PN40</p> <p>H29 Sleeve G 3/4, as per DIN2986</p>	<p><b>Application</b> The application areas for a heating jacket are for securing plants with media that tends to be viscose, crystallise, or clog.</p> <p><b>Technical design</b> The heating jacket is constructed around the change-over valve as a welded structure based on the order. It is available with loose flange or sleeve heating connections. Available for DN 25 to DN 500 / NPS 1" to 20"</p>
<p><b>Oil and grease free</b></p> 	J85	<p><b>Application</b> With this option, freedom from oil and grease is guaranteed for the change-over valve.</p> <p><b>Technical design</b> A visual check is performed for freedom from oil and grease, in which a check is made to ensure the change-over valve is free of oil and grease. Available for DN 25 to DN 500 / NPS 1" to 20"</p>
<p><b>Reducers welded</b></p> 	Please specify the flange standard, DN and PN	<p><b>Application</b> With the exception of the Modulate Action series, all LESER safety valves have a larger nominal diameter at the outlet than at the inlet. That way, reductions of 1, 2 or 3 nominal diameters can be supported.</p> <p><b>Technical design</b> You can find details on the reducers on pages 03/03 and 03/04. Available for DN 25 to DN 300 / NPS 1" to 12"</p>
<p><b>Lockable combination Hand and sprocket wheel</b></p> 	Y35	<p><b>Application</b> When using a lockable combination, the change-over valves are equipped with a hand and sprocket wheel combination.</p> <p><b>Technical design</b> Details on the sprocket wheel can be found on page 03/02. Available for DN 25 to DN 500 / NPS 1" to 20"</p>
<p><b>Lockable combination Hand and sprocket wheel and chain</b></p> 	Y36	<p><b>Application</b> When using a lockable combination, the change-over valves are equipped with a hand and sprocket wheel combination and connected with a chain.</p> <p><b>Technical design</b> Details on the sprocket wheel and chain can be found on page 03/02. Available for DN 25 to DN 500 / NPS 1" to 20"</p>

Change-Over Valve Catalog  
Edition April 2009

LWN 487.01-E / 04.2009 / 3000

**LESER**

[The-Safety-Valve.com](http://The-Safety-Valve.com)

LESER GmbH & Co. KG

20537 Hamburg, Wendenstr. 133-135  
20506 Hamburg, P.O. Box 26 16 51

Fon +49 (40) 251 65-100  
Fax +49 (40) 251 65-500

E-Mail: [sales@leser.com](mailto:sales@leser.com)  
[www.leser.com](http://www.leser.com)