



# High Performance

Flanged Safety Relief Valves

Series 441

Series 441 Full nozzle

Series XXL

Series 444

Series 458

# CATALOG

**LESER**

The-Safety-Valve.com

**Valve finder**  
**How to find the right Product Group**

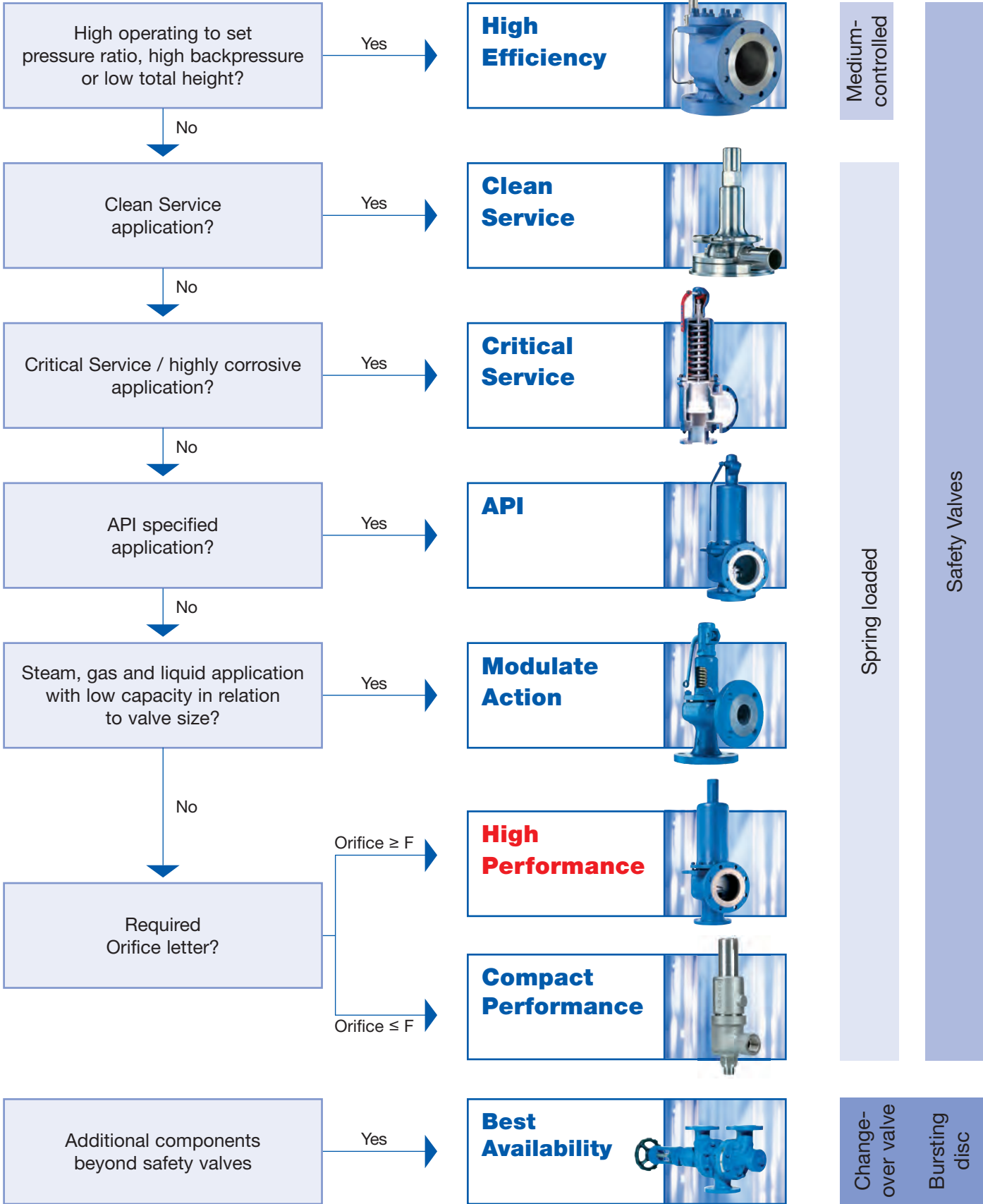

# Contents

<b>General</b>	
Valve finder	2
General Information	4

<b>Type 441, 442 DIN</b>	
<b>Materials</b>	
• Conventional design	8
• Balanced bellows design	10
<b>Article numbers</b>	12
<b>Dimensions and weights</b>	13
<b>Pressure temperature ratings</b>	15
Flange drillings	19
Flange facings / Change of nominal diameter	20

<b>Type 441, 442 ANSI</b>	
<b>Materials</b>	
• Conventional design	22
• Balanced bellows design	24
<b>Article numbers</b>	26
<b>Dimensions and weights</b>	27
<b>Pressure temperature ratings</b>	29
Flange drillings and facings	31

<b>Type 441, 442 Full nozzle DIN, Full nozzle ANSI</b>	
<b>Materials</b>	
• Conventional design	34
• Balanced bellows design	36
<b>Article numbers</b>	38
<b>Dimensions and weights</b>	
Type 441, 442 Full nozzle DIN	39
Type 441, 442 Full nozzle ANSI	40
<b>Pressure temperature ratings</b>	
Type 441, 442 Full nozzle DIN	42
Type 441, 442 Full nozzle ANSI	44
Flange drillings	46
Flange facings	47

<b>Series 441, Series 441 Full nozzle</b>	
Approvals	48
Available options	49
LESER Original Spare Parts Kits	50

<b>Type 441, 442 XXL</b>	
<b>Materials</b>	
• Conventional design	52
• Balanced bellows design	54
<b>Article numbers</b>	56
<b>Dimensions and weights</b>	57
<b>Pressure temperature ratings</b>	59
Flange drillings and facings	61
Approvals	62
Available options	63

<b>Type 444 DIN, ANSI</b>	
<b>Materials</b>	
• Conventional design	65
<b>Article numbers</b>	67
<b>Dimensions and weights</b>	68
<b>Pressure temperature ratings</b>	69
Flange drillings and facings	70
Approvals	71
Available options	72

<b>Type 455, 456</b>	
<b>Materials</b>	
• Conventional design	74
• Balanced bellows design	76
<b>Article numbers</b>	78
<b>Dimensions and weights</b>	79
<b>Pressure temperature ratings</b>	81
Flange drillings	83
Flange facings	84
Approvals	85
Available options	86

<b>Type 457, 458</b>	
<b>Materials</b>	
• Conventional design	88
• Balanced bellows design	90
<b>Article numbers</b>	92
<b>Dimensions and weights</b>	93
<b>Pressure temperature ratings</b>	95
Flange drillings	97
Flange facings	98
Approvals	99
Available options	100

## General Information

### LESER – High Performance Sicherheitsventile

The High Performance product group represents

- ✓ High capacity related to the safety valve size
- ✓ High adaptability
- ✓ Excellent price / performance ratio

#### LESERs High Performance Safety Valves

- Are designed to meet all industrial applications.
- Open rapidly with an overpressure of 5 % to the full design lift.
- Are used particularly for vapours and gases where the maximum mass flow has to be discharged rapidly.
- Have a maximum blowdown of minus 10 % for steam/ gas service and minus 20 % for liquid service.
- Are one of the best selling spring loaded safety valve worldwide.
- Are developed in a close cooperation with plant engineers and service specialists.
- Serve for protection of processes and equipment.
- Are approved by all important approval organisations worldwide which ensures the worldwide applicability e.g.:
  - European Community: CE-marking acc. to Pressure Equipment Directive (PED) 97/23/EC resp. 2014/68/EU and EN ISO 4126-1
  - USA: UV-stamp acc. to ASME Section VIII Division 1, National Board certified capacities
  - Germany: VdTÜV approval acc. to PED, EN ISO 4126-1, TÜV SV 100 and AD 2000-Merkblatt A2
  - Canada: Canadian Registration Number acc. to the requirements of particular provinces
  - China: AQSIQ based on the approval acc. to ASME Section VIII Division 1 and AD 2000-Merkblatt A2
  - Eurasian Custom Union: Approval acc. to Eurasian Custom Union (EAC - Eurasian Conformity)

Furthermore, all LESER High Performance safety valves are designed, marked, produced and approved acc. to the requirements of the following regulations (directives, codes, rules and standards).

EN ISO 4126-7, EN 12266-1/-2, EN 1092 Teil I and II flanging, ASME PTC 25, ASME-Code Sec. II, ASME B16.34 and ASME B16.5-flanging, API Std. 527, API RP 576, AD 2000-Merkblatt A4, AD 2000-Merkblatt HP0.



## General Information

### Applications

#### LESER – High Performance Safety Valves

Are the ultimate solution for all industrial applications for steam, gas and liquid.

Typical applications for LESER High Performance Safety Valves are:

##### Series 441

- Protection of chemical processes and equipment (e.g. distillation columns)
- Heat exchangers
- Low and medium pressure steam
- Blowers and turbo compressors

##### Series XXL

- Low pressure steam at big power stations
- Capacities beyond the limits of API and Series 441

##### Series 444

- OEM in dyeing machines or filter constructions
- Stainless steel applications up to 16 bar / 232 psig

##### Series 441 Full Nozzle

- Same applications like Series 441 when full nozzle design is preferred.
- Special requirement for nozzle material

##### Series 458

- Power stations and industrial superheated steam generation
- Required flange classes  $\geq$  PN 63 / CL600
- Protection of high pressure Chemical processes, e.g.  $\text{NH}_3$  synthesis,  $\text{CO}_2$  extraction
- Desalination plants

### General Design Features

#### LESERs High Performance Safety Valves

Offer a large variety of types, materials and options to suit any application:

- 14 valve sizes from DN 20 to DN 400 –  $\frac{3}{4}$ " to 16" provide a high connectivity to the application
- Inlet pressure ratings PN 16 to PN 400 / class 150 to class 2500 to fit all required design pressures
- Orifice sizes from E to  $> 3 \times T$  cover all capacity requirements
- Large variety of body materials; e.g.

- 0.6025 / grey iron
- 0.7043 / ductile iron
- 1.0619 / WCB
- 1.4408 / CF8M
- 1.7357 / WC6

can be selected acc. to the application

- Set pressures from 0.1 to 300 bar / 1.5 to 4350 psig make this product group suitable for all industrial processes
- Operating temperatures from  $-270$  to  $550$  °C /  $-454$  to  $1022$  °F cover a wide range of applications
- LESER Nanotightness as standard for metal-to-metal sealings. The nanotightness exceeds the requirements for functional tightness of API 527 by 50% which means e.g. less pollution when discharge to atmosphere, 50% reduction in medium loss and increased plant efficiency
- One design and spring (single trim) for steam, gas and liquid applications reduces the number of spare parts and ensure an easier maintenance
- High capacity compared to the API requirements to reduce installation costs
- Ringless design needs no trim adjustments for easy maintenance
- One-piece spindle reduces friction which is leading to high operation accuracy
- Self-draining body design, avoids residues and reduces corrosion

### Options

LESER – High Performance Safety Valves can be customized with a great variety of options, e.g.

- O-ring disc for superior tightness
- Stellite or hardened metal sealing for longer product life
- Stainless steel bellows for back pressure compensation
- Heating jacket for applications with high viscosity fluids
- Every part can be replaced by other material acc. to customer specification





**Type 442 DIN**  
Plain lever H3  
Open bonnet  
Conventional design



**Type 441 DIN**  
Packed lever H4  
Closed bonnet  
Conventional design

## Type 441, 442 DIN Flanged Safety Relief Valves

<b>Contents</b>	<b>Page</b>
<b>Materials</b>	
• Conventional design	8
• Balanced bellows design	10
<b>Article numbers</b>	12
<b>Dimensions and weights</b>	
• Metric Units	13
• US Units	14
<b>Pressure temperature ratings</b>	
• Metric Units	15
• US Units	17
Flange drillings	19
Flange facings	20
Change of nominal diameter	20
<b>Series 441, Series 441 Full nozzle</b>	
Approvals	48
Available options	49
LESER Original Spare Parts Kits	50

**Type 441, 442 DIN**  
**Conventional design**

Type 441, 442  
 DIN

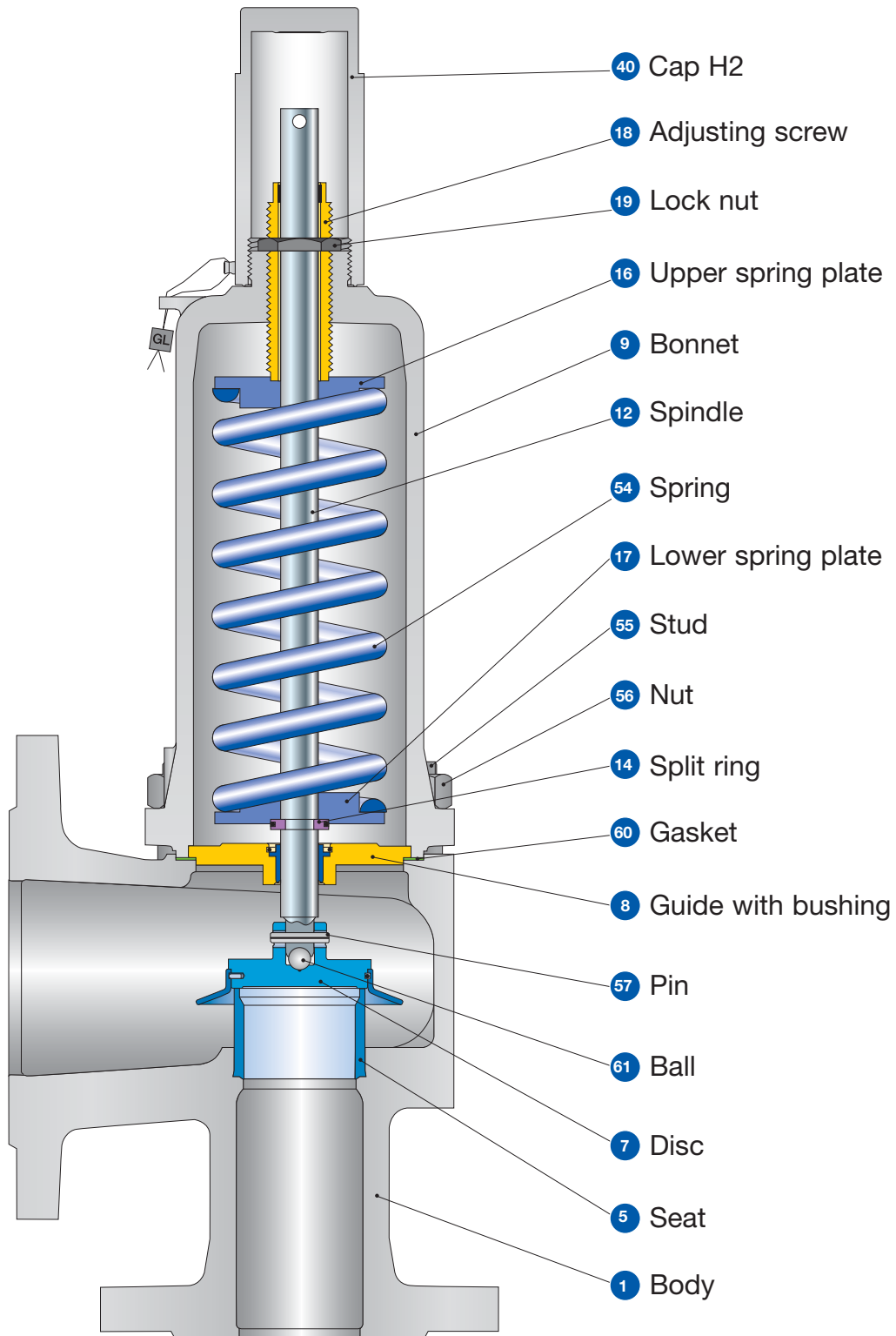



## Type 441, 442 DIN

### Conventional design

#### Materials

Item	Component	Type 4411 / 4421 DIN	Type 4415 / 4425 DIN	Type 4412 / 4422 DIN	Type 4414 DIN
1	Body	0.6025	0.7043	1.0619	1.4408
		Cast iron	Ductile Gr. 60-40-18	SA 216 WCB	SA 351 CF8M
5	Seat	1.4404	1.4404	1.4404	1.4404
		316L	316L	316L	316L
7	Disc	1.4122	1.4122	1.4122	1.4404
		Hardened stainless steel	Hardened stainless steel	Hardened stainless steel	316L
8	Guide with bushing	1.4104, 1.0501, 0.7040	1.4104, 1.0501, 0.7040	1.4104, 1.0501, 0.7040	1.4404
		Chrome or carbon steel	Chrome or carbon steel	Chrome or carbon steel	316L
		1.4104 tenifer	1.4104 tenifer	1.4104 tenifer	-
		Chrome steel tenifer	Chrome steel tenifer	Chrome steel tenifer	-
9	Bonnet	0.7040, 0.7043, 1.0619	0.7040, 0.7043, 1.0619	0.7040, 0.7043, 1.0619	1.4408, 1.4404, 1.4571
		Ductile Gr. 60-40-18, SA 216 WCB	Ductile Gr. 60-40-18, SA 216 WCB	Ductile Gr. 60-40-18, SA 216 WCB	SA 351 CF8M, SA 479 316L, SA 479 316Ti
12	Spindle	1.4021	1.4021	1.4021	1.4404
		420	420	420	316L
14	Split ring	1.4104	1.4104	1.4104	1.4404
		Chrome steel	Chrome steel	Chrome steel	316L
16/17	Spring plate	1.0718	1.0718	1.0718	1.4404
		Steel	Steel	Steel	316L
18	Adjusting screw with bushing	1.4104 PTFE	1.4104 PTFE	1.4104 PTFE	1.4404 PTFE
		Chrome steel PTFE	Chrome steel PTFE	Chrome steel PTFE	316L PTFE
19	Lock nut	1.0718	1.0718	1.0718	1.4404
		Steel	Steel	Steel	316L
40	Cap H2	1.0460 or 0.7043	1.0460 or 0.7043	1.0460 or 0.7043	1.4404
		SA 105 or Gr. 60-40-18	SA 105 or Gr. 60-40-18	SA 105 or Gr. 60-40-18	316L
54	Spring standard	1.1200, 1.8159, 1.7102	1.1200, 1.8159, 1.7102	1.1200, 1.8159, 1.7102	1.4310
		Carbon steel	Carbon steel	Carbon steel	Stainless steel
54	Spring optional	1.4310	1.4310	1.4310	-
		Stainless steel	Stainless steel	Stainless steel	-
55	Stud	1.1181	1.1181	1.1181	1.4401
		Steel	Steel	Steel	B8M
56	Nut	1.0501	1.0501	1.0501	1.4401
		2H	2H	2H	8M
57	Pin	1.4310	1.4310	1.4310	1.4310
		Stainless steel	Stainless steel	Stainless steel	Stainless steel
60	Gasket	Graphite / 1.4401	Graphite / 1.4401	Graphite / 1.4401	Graphite / 1.4401
		Graphite / 316	Graphite / 316	Graphite / 316	Graphite / 316
61	Ball	1.3541	1.3541	1.3541	1.4401
		Hardened stainless steel	Hardened stainless steel	Hardened stainless steel	316

**Please notice:**

- Modifications reserved by LESER
- If several materials are specified LESER defines the material.
- LESER can upgrade materials without notice.
- Every part can be replaced by other material acc. to customer specification.

**Type 441, 442 DIN**  
**Balanced bellows design**

Type 441, 442  
 DIN

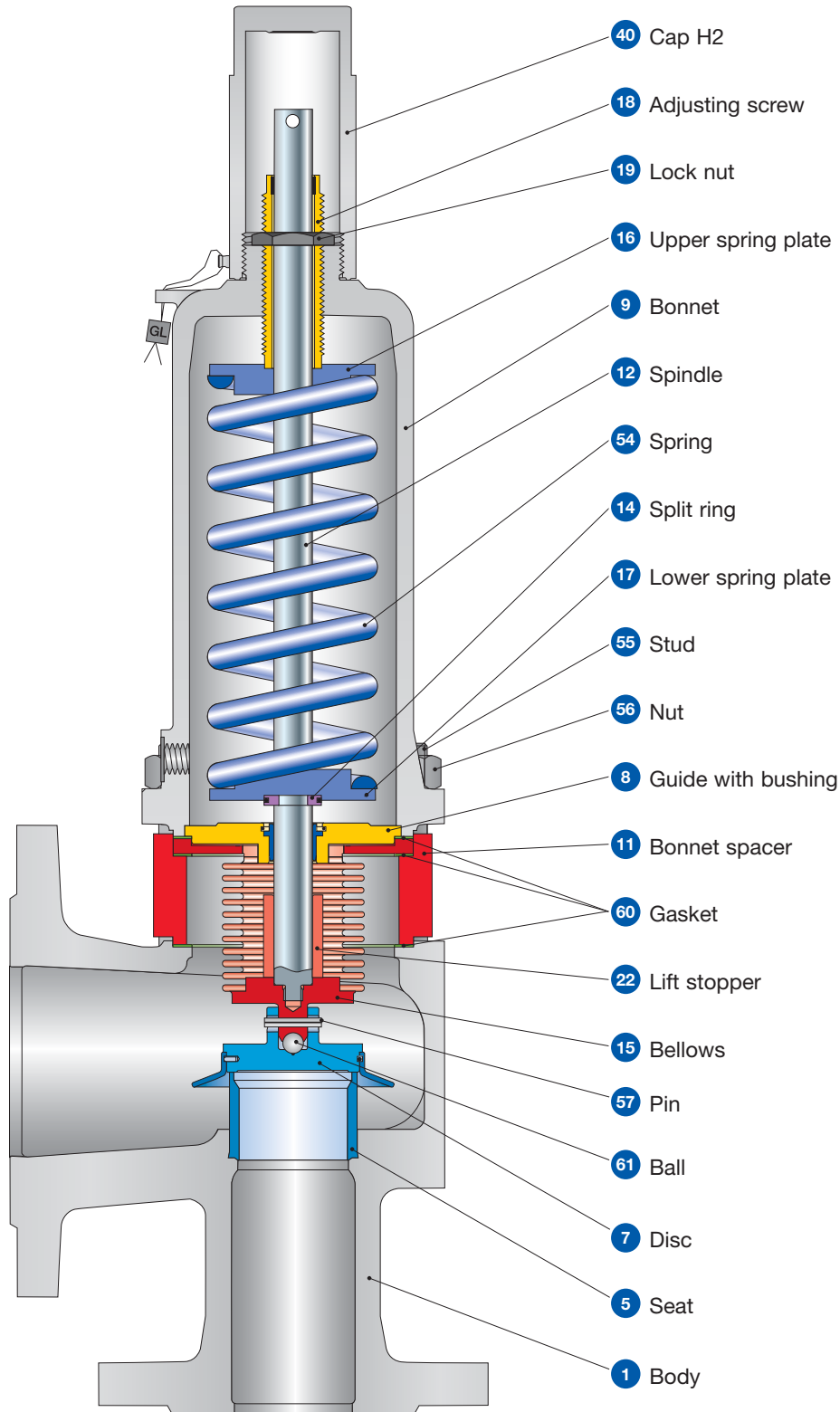

## Type 441, 442 DIN

### Balanced bellows design

#### Materials

Item	Component	Type 4411 / 4421 DIN	Type 4415 / 4425 DIN	Type 4412 / 4422 DIN	Type 4414 DIN
1	Body	0.6025	0.7043	1.0619	1.4408
		Cast iron	Ductile Gr. 60-40-18	SA 216 WCB	SA 351 CF8M
5	Seat	1.4404	1.4404	1.4404	1.4404
		316L	316L	316L	316L
7	Disc	1.4122	1.4122	1.4122	1.4404
		Hardened stainless steel	Hardened stainless steel	Hardened stainless steel	316L
8	Guide with bushing	1.4104, 1.0501, 0.7040	1.4104, 1.0501, 0.7040	1.4104, 1.0501, 0.7040	1.4404
		Chrome or carbon steel	Chrome or carbon steel	Chrome or carbon steel	316L
		1.4104 tenifer	1.4104 tenifer	1.4104 tenifer	–
		Chrome steel tenifer	Chrome steel tenifer	Chrome steel tenifer	–
9	Bonnet	0.7040, 0.7043, 1.0619	0.7040, 0.7043, 1.0619	0.7040, 0.7043, 1.0619	1.4408, 1.4404, 1.4571
		Ductile Gr. 60-40-18, SA 216 WCB	Ductile Gr. 60-40-18, SA 216 WCB	Ductile Gr. 60-40-18, SA 216 WCB	SA 351 CF8M, SA 479 316L, SA 479 316Ti
11	Bonnet spacer	1.0460	1.0460	1.0460	1.4404
		Carbon steel	Carbon steel	Carbon steel	316L
12	Spindle	1.4404	1.4404	1.4404	1.4404
		316L	316L	316L	316L
14	Split ring	1.4104	1.4104	1.4104	1.4404
		Chrome steel	Chrome steel	Chrome steel	316L
15	Bellows	1.4571	1.4571	1.4571	1.4571
		316Ti	316Ti	316Ti	316Ti
16/17	Spring plate	1.0718	1.0718	1.0718	1.4404
		Steel	Steel	Steel	316L
18	Adjusting screw with bushing	1.4104 PTFE	1.4104 PTFE	1.4104 PTFE	1.4404 PTFE
		Chrome steel PTFE	Chrome steel PTFE	Chrome steel PTFE	316L PTFE
19	Lock nut	1.0718	1.0718	1.0718	1.4404
		Steel	Steel	Steel	316L
22	Lift stopper	1.4404	1.4404	1.4404	1.4404
		316L	316L	316L	316L
40	Cap H2	1.0460 or 0.7043	1.0460 or 0.7043	1.0460 or 0.7043	1.4404
		SA 105 or Gr. 60-40-18	SA 105 or Gr. 60-40-18	SA 105 or Gr. 60-40-18	316L
54	Spring standard	1.1200, 1.8159, 1.7102	1.1200, 1.8159, 1.7102	1.1200, 1.8159, 1.7102	1.4310
		Carbon steel	Carbon steel	Carbon steel	Stainless steel
	Spring optional	1.4310	1.4310	1.4310	–
55	Stud	1.4401	1.4401	1.4401	1.4401
		B8M	B8M	B8M	B8M
56	Nut	1.4401	1.4401	1.4401	1.4401
		8M	8M	8M	8M
57	Pin	1.4310	1.4310	1.4310	1.4310
		Stainless steel	Stainless steel	Stainless steel	Stainless steel
60	Gasket	Graphite / 1.4401	Graphite / 1.4401	Graphite / 1.4401	Graphite / 1.4401
		Graphite / 316	Graphite / 316	Graphite / 316	Graphite / 316
61	Ball	1.3541	1.3541	1.3541	1.4401
		Hardened stainless steel	Hardened stainless steel	Hardened stainless steel	316

**Please notice:**

- Modifications reserved by LESER
- If several materials are specified LESER defines the material.
- LESER can upgrade materials without notice.
- Every part can be replaced by other material acc. to customer specification.

## Type 441, 442 DIN

### Article numbers

Type 441, 442  
DIN

		DN <sub>i</sub>	20	20	25	32	40	50	65	80	100	125	150	200
		DN <sub>o</sub>	32	40	40	50	65	80	100	125	150	200	250	300
		Actual Orifice diameter d <sub>o</sub> [mm]	18	18	23	29	37	46	60	74	92	98	125	165
		Actual Orifice area A <sub>o</sub> [mm <sup>2</sup> ]	254	254	416	661	1075	1662	2827	4301	6648	7543	12272	21382
<b>Body material: 0.6025 (cast iron)</b>														
Bonnet closed	H2	Art. No. 4411.	4372	-	4382	4392	4402	4412	4422	4432	4442	4452	4462	-
	H3	Art. No. 4411.	4373	-	4383	4393	4403	4413	4423	4433	4443	4453	-	-
	H4	Art. No. 4411.	4374	-	4384	4394	4404	4414	4424	4434	4444	4454	4464	-
open	H3	Art. No. 4421.	4375	-	4385	4395	4405	4415	4425	4435	4445	4455	4465	-
<b>Body material: 0.7043 (ductile Gr. 60-40-18)</b>														
Bonnet closed	H2	Art. No. 4415.	-	-	7382	7392	7402	7412	7422	7432	7442	7452	7462	7472
	H3	Art. No. 4415.	-	-	7383	7393	7403	7413	7423	7433	7443	7453	-	-
	H4	Art. No. 4415.	-	-	7384	7394	7404	7414	7424	7434	7444	7454	7464	7474
open	H3	Art. No. 4425.	-	-	7385	7395	7405	7415	7425	7435	7445	7455	7465	7475
<b>Body material: 1.0619 (WCB)</b>														
Bonnet closed	H2	Art. No. 4412.	-	4502	4512	4522	4532	4542	4552	4562	4572	4582	4592	4612
	H3	Art. No. 4412.	-	4503	4513	4523	4533	4543	4553	4563	4573	4583	-	-
	H4	Art. No. 4412.	-	4504	4514	4524	4534	4544	4554	4564	4574	4584	4594	4614
open	H3	Art. No. 4422.	-	4505	4515	4525	4535	4545	4555	4565	4575	4585	4595	4615
<b>Body material: 1.4408 (CF8M)</b>														
Bonnet closed	H2	Art. No. 4414.	-	-	4642	4652	4662	4672	4682	4692	4702	4712	4722	-
	H4	Art. No. 4414.	-	-	4644	4654	4664	4674	4684	4694	4704	4714	4724	-

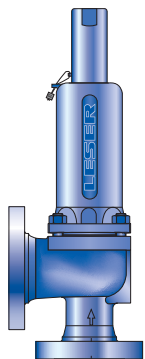

**Type 441**  
Cap H2  
Closed bonnet  
Conventional design

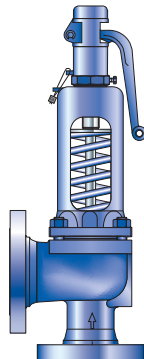

**Type 442**  
Plain lever H3  
Open bonnet  
Conventional design

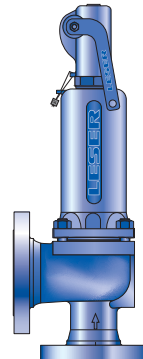

**Type 441**  
Packed lever H4  
Closed bonnet  
Conventional design

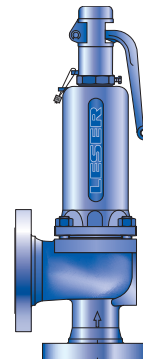

**Type 441**  
Plain lever H3  
Closed bonnet  
Conventional design

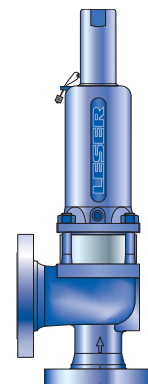

**Type 441**  
Cap H2  
Closed bonnet  
Balanced bellows design

## Type 441, 442 DIN

### Dimensions and weights

Metric Units

	DN <sub>i</sub>	20	20	25	32	40	50	65	80	100	125	150	200
	DN <sub>o</sub>	32	40	40	50	65	80	100	125	150	200	250	300
	Actual Orifice diameter d <sub>o</sub> [mm]	18	18	23	29	37	46	60	74	92	98	125	165
	Actual Orifice area A <sub>o</sub> [mm <sup>2</sup> ]	254	254	416	661	1075	1662	2827	4301	6648	7543	12272	21382
<b>Weight</b>		9	9	9	12	16	22	32	56	75	85	131	285
[kg]	with bellows	9,4	9,4	10	13	17	24	36	60	83	93	142	289
<b>Center to face</b>	Inlet a	85	85	105	115	140	150	170	195	220	250	285	290
[mm]	Outlet b	95	95	100	110	115	120	140	160	180	200	225	300
<b>Height (H4)</b>	Standard H max.	304	304	339	446	512	569	699	801	883	913	1083	1380
[mm]	Bellows H max.	337	337	378	488	550	615	769	860	939	969	1141	1380
<b>Support brackets</b>	A									277	277	320	490
[mm]	B									160	160	185	<sup>1)</sup>
(drilled only on request, Option code H42)	C									Ø 18	Ø 18	Ø 18	Ø 18
	D									293	318	392	<sup>1)</sup>
	E									21	21	28	<sup>1)</sup>

#### Body material: 0.6025 (cast iron)

<b>DIN Flange<sup>2)</sup></b>	Inlet	PN 16	-										PN 16
	Outlet	PN 16	-										PN 16

#### Body material: 0.7043 (ductile Gr. 60-40-18)

<b>DIN Flange<sup>2)</sup></b>	Inlet	-	-					PN 40				PN 16	PN 25
	Outlet	-	-					PN 16					PN 10

#### Body material: 1.0619 (WCB)

<b>DIN Flange<sup>2)</sup></b>	Inlet	-	-					PN 40					PN 25
	Outlet	-	-					PN 16					

#### Body material: 1.4408 (CF8M)

<b>DIN Flange<sup>2)</sup></b>	Inlet	-	-					PN 40					
	Outlet	-	-					PN 16					

<sup>1)</sup>

Body material	B	D	E
	[mm]	[mm]	[mm]
0.6025	150	290	16
0.7043	150	489	25
1.0619	160	489	25
1.4408	150	489	25

<sup>2)</sup> Standard flange rating. For other flange drillings and facings please refer to page 19.

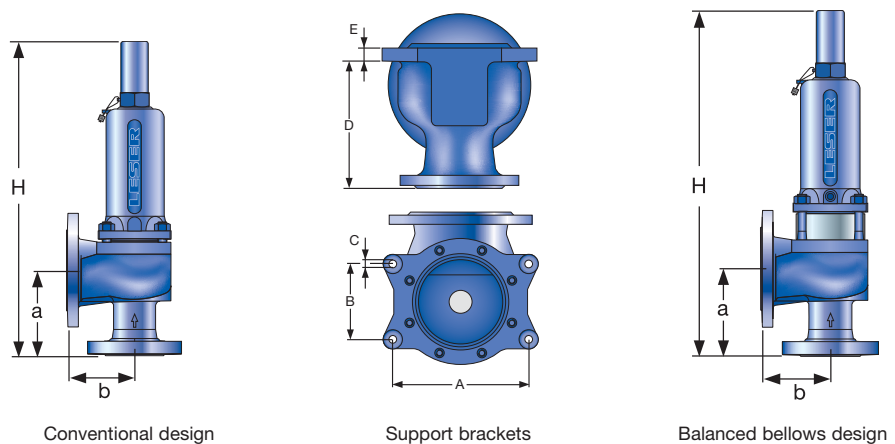

# Type 441, 442 DIN

## Dimensions and weights

### US Units

	DN <sub>i</sub>	20	20	25	32	40	50	65	80	100	125	150	200
	DN <sub>o</sub>	32	40	40	50	65	80	100	125	150	200	250	300
	Actual Orifice diameter d <sub>o</sub> [inch]	0.71	0.71	0.91	1.14	1.46	1.81	2.36	2.91	3.62	3.86	4.92	6.5
	Actual Orifice area A <sub>o</sub> [inch <sup>2</sup> ]	0.394	0.394	0.644	1.024	1.667	2.576	4.383	6.666	10.304	11.691	19.021	33.142
<b>Weight</b> [lbs]		20	20	20	26	35	49	71	123	165	187	289	628
	with bellows	21	21	21	28	38	52	79	132	183	205	313	637
<b>Center to face</b> [inch]	Inlet a	3 11/32	3 11/32	4 1/8	4 17/32	5 16/32	5 29/32	6 11/16	7 11/16	8 21/32	9 27/32	11 7/32	11 13/32
	Outlet b	3 3/4	3 3/4	3 15/16	4 11/32	4 17/32	4 23/32	5 16/32	6 5/16	7 3/32	7 7/8	8 27/32	11 13/16
<b>Height (H4)</b> [inch]	Standard H max.	11 13/16	11 13/16	13 11/32	17 9/16	20 5/32	22 13/32	27 17/32	31 17/32	34 3/4	35 15/16	42 5/8	54 11/32
	Bellows H max.	13 9/32	13 9/32	14 7/8	19 7/32	21 21/32	24 7/32	30 9/32	33 27/32	36 31/32	38 5/32	45	54 11/32
<b>Support brackets</b> [inch]	A									10 29/32	10 29/32	12 19/32	19 19/32
	B									6 1/4	6 1/4	7 9/32	1)
	C									Ø 3/4	Ø 3/4	Ø 3/4	Ø 3/4
	D									11 17/32	12 17/32	15 7/16	1)
	E									26/32	26/32	1 3/32	1)
(drilled only on request, Option code H42)													

#### Body material: 0.6025 (cast iron)

<b>DIN Flange<sup>2)</sup></b>	Inlet	PN 16	-											PN 16
	Outlet	PN 16	-											PN 16

#### Body material: 0.7043 (ductile Gr. 60-40-18)

<b>DIN Flange<sup>2)</sup></b>	Inlet	-	-					PN 40						PN 16	PN 25
	Outlet	-	-					PN 16							PN 10

#### Body material: 1.0619 (WCB)

<b>DIN Flange<sup>2)</sup></b>	Inlet	-	-					PN 40							PN 25
	Outlet	-	-					PN 16							

#### Body material: 1.4408 (CF8M)

<b>DIN Flange<sup>2)</sup></b>	Inlet	-	-					PN 40							
	Outlet	-	-					PN 16							

Body material	B	D	E
	[inch]	[inch]	[inch]
0.6025	5 29/32	11 13/32	5/8
0.7043	5 29/32	11 17/32	13/16
1.0619	6 1/4	11 17/32	13/16
1.4408	5 29/32	11 17/32	13/16

<sup>2)</sup> Standard flange rating. For other flange drillings please refer to page 19.

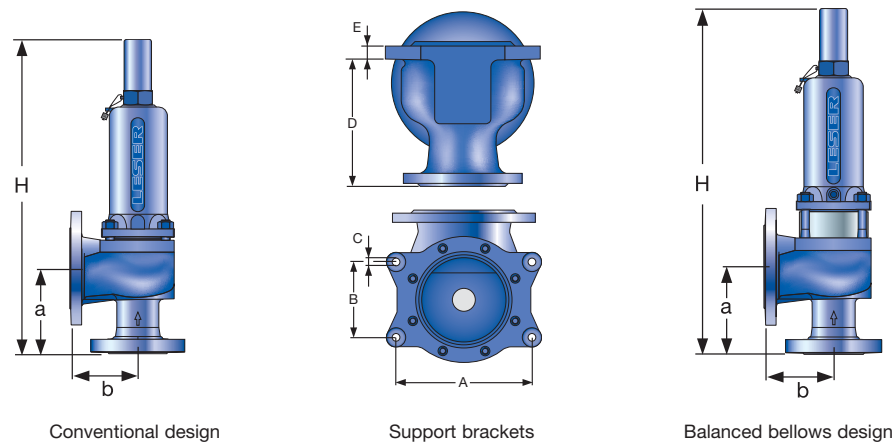

## Type 441, 442 DIN

### Pressure temperature ratings

#### Metric Units

	DN <sub>i</sub>	20	20	25	32	40	50	65	80	100	125	150	200
	DN <sub>o</sub>	32	40	40	50	65	80	100	125	150	200	250	300
	Actual Orifice diameter d <sub>o</sub> [mm]	18	18	23	29	37	46	60	74	92	98	125	165
	Actual Orifice area A <sub>o</sub> [mm <sup>2</sup> ]	254	254	416	661	1075	1662	2827	4301	6648	7543	12272	21382

#### Body material: 0.6025 (cast iron)

<b>DIN Flange</b>	Inlet	<b>PN 16</b>	-	<b>PN 16</b>										-
	Outlet	<b>PN 16</b>	-	<b>PN 16</b>										-
<b>Minimum set pressure</b>	p [bar <sub>g</sub> ] S/G/L	0.1	-	0.1	0.1	0.1	0.1	0.1	0.1	0.1	0.1	0.1	-	
<b>Min. set pressure<sup>1)</sup> standard bellows</b>	p [bar <sub>g</sub> ] S/G/L	3	-	3	3	3	3	3	3	2.74	2.01	0.2	-	
<b>Min. set pressure low press. bellows</b>	p [bar <sub>g</sub> ] S/G/L	2.00	-	0.98	1.41	1.11	1.81	1.50	1.05	1.18	1.41	-	-	
<b>Maximum set pressure</b>	p [bar <sub>g</sub> ] S/G/L	16	-	16	16	16	16	16	16	16	16	16	-	
<b>Max. set pressure with special spring</b>	p [bar <sub>g</sub> ] S/G/L	16	-	16	16	16	16	16	16	16	16	16	-	
<b>Temperature acc. to DIN EN</b>	min. [°C]	-10	-	-10										-
	max. [°C]	+300	-	+300										-
<b>Temperature acc. to ASME</b>	min. [°C]	-	-	-										-
	max. [°C]	-	-	-										-

#### Body material: 0.7043 (ductile Gr. 60-40-18)

<b>DIN Flange</b>	Inlet	-	-	<b>PN 40</b>							<b>PN 16</b>		<b>PN 25</b>
	Outlet	-	-	<b>PN 16</b>							<b>PN 16</b>		<b>PN 10</b>
<b>Minimum set pressure</b>	p [bar <sub>g</sub> ] S/G/L	-	-	0.1	0.1	0.1	0.1	0.1	0.1	0.1	0.1	0.1	0.1
<b>Min. set pressure<sup>1)</sup> standard bellows</b>	p [bar <sub>g</sub> ] S/G/L	-	-	3	3	3	3	3	3	2.74	2.01	0.2	0.2
<b>Min. set pressure low press. bellows</b>	p [bar <sub>g</sub> ] S/G/L	-	-	0.98	1.41	1.11	1.81	1.50	1.05	1.18	1.41	-	-
<b>Maximum set pressure</b>	p [bar <sub>g</sub> ] S/G/L	-	-	40	40	40	40	40	32	40	16	16	20
<b>Max. set pressure with special spring</b>	p [bar <sub>g</sub> ] S/G/L	-	-	40	40	40	40	40	40	40	16	16	25
<b>Temperature acc. to DIN EN</b>	min. [°C]	-	-	-60									
	max. [°C]	-	-	+350									
<b>Temperature acc. to ASME</b>	min. [°C]	-	-	-10									
	max. [°C]	-	-	+350									

<sup>1)</sup> Min. set pressure standard bellows = Max. set pressure low pressure bellows.

## Type 441, 442 DIN

### Pressure temperature ratings

#### Metric Units

DN <sub>i</sub>	20	20	25	32	40	50	65	80	100	125	150	200
DN <sub>o</sub>	32	40	40	50	65	80	100	125	150	200	250	300
Actual Orifice diameter d <sub>o</sub> [mm]	18	18	23	29	37	46	60	74	92	98	125	165
Actual Orifice area A <sub>o</sub> [mm <sup>2</sup> ]	254	254	416	661	1075	1662	2827	4301	6648	7543	12272	21382

#### Body material: 1.0619 (WCB)

DIN Flange		Inlet	PN 40										PN 25
			PN 16										
<b>Minimum set pressure</b>	p [bar <sub>g</sub> ] S/G/L	-	0.1	0.1	0.1	0.1	0.1	0.1	0.1	0.1	0.1	0.1	0.1
		-	3	3	3	3	3	3	3	2.74	2.01	0.2	0.2
<b>Min. set pressure<sup>1)</sup> standard bellows</b>	p [bar <sub>g</sub> ] S/G/L	-	2.00	0.98	1.41	1.11	1.81	1.50	1.05	1.18	1.41	-	-
		-	40	40	40	40	40	40	32	40	28	17	20
<b>Maximum set pressure</b>	p [bar <sub>g</sub> ] S/G/L	-	40	40	40	40	40	40	40	40	28	25	25
		-	-	-	-	-	-	-	-	-	-	-	-
<b>Temperature<sup>2)</sup> acc. to DIN EN</b>	min. [°C]	-	-85										
		-	+450										
<b>Temperature<sup>2)</sup> acc. to ASME</b>	min. [°C]	-	-29										
		-	+427										

#### Body material: 1.4408 (CF8M)

DIN Flange		Inlet	PN 40										-
			PN 16										
<b>Minimum set pressure</b>	p [bar <sub>g</sub> ] S/G/L	-	0.1	0.1	0.1	0.1	0.1	0.1	0.1	0.1	0.1	0.1	-
		-	3	3	3	3	3	3	3	2.74	2.01	0.2	-
<b>Min. set pressure<sup>1)</sup> standard bellows</b>	p [bar <sub>g</sub> ] S/G/L	-	0.98	1.41	1.11	1.81	1.50	1.05	1.18	1.41	-	-	
		-	40	40	40	33	28	13.6	20	17.7	7	-	
<b>Maximum set pressure</b>	p [bar <sub>g</sub> ] S/G/L	-	40	40	40	37	28	25	26	24	10	-	
		-	-	-	-	-	-	-	-	-	-	-	
<b>Temperature<sup>2)</sup> acc. to DIN EN</b>	min. [°C]	-	-270										
		-	+400										
<b>Temperature<sup>2)</sup> acc. to ASME</b>	min. [°C]	-	-268										
		-	+538										

<sup>1)</sup> Min. set pressure standard bellows = Max. set pressure low pressure bellows.

<sup>2)</sup> Between -10 °C and lowest temperature indicated „AD 2000-Merkblatt“ W10 shall be taken into account.



## Type 441, 442 DIN

### Pressure temperature ratings

#### US Units

	DN <sub>i</sub>	20	20	25	32	40	50	65	80	100	125	150	200	
	DN <sub>o</sub>	32	40	40	50	65	80	100	125	150	200	250	300	
Actual Orifice diameter d <sub>0</sub> [inch]		0.71	0.71	0.91	1.14	1.46	1.81	2.36	2.91	3.62	3.86	4.92	6.5	
Actual Orifice area A <sub>0</sub> [inch <sup>2</sup> ]		0.394	0.394	0.644	1.024	1.667	2.576	4.383	6.666	10.304	11.691	19.021	33.142	
<b>Body material: 0.6025 (cast iron)</b>														
<b>DIN Flange</b>	Inlet	<b>PN 16</b>	-	<b>PN 16</b>										-
	Outlet	<b>PN 16</b>	-	<b>PN 16</b>										-
<b>Minimum set pressure</b>	p [psig] S/G/L	1.5	-	1.5	1.5	1.5	1.5	1.5	1.5	1.5	1.5	1.5	-	
<b>Min. set pressure<sup>1)</sup> standard bellows</b>	p [psig] S/G/L	43.5	-	43.5	43.5	43.5	43.5	43.5	43.5	39.7	29.1	2.9	-	
<b>Min. set pressure low press. bellows</b>	p [psig] S/G/L	29	-	14	20	16	26	22	15	17	20	-	-	
<b>Maximum set pressure</b>	p [psig] S/G/L	232	-	232	232	232	232	232	232	232	232	232	-	
<b>Max. set pressure with special spring</b>	p [psig] S/G/L	232	-	232	232	232	232	232	232	232	232	232	-	
<b>Temperature acc. to DIN EN</b>	min. [°F]	+14	-	+14										-
	max. [°F]	+572	-	+572										-
<b>Temperature acc. to ASME</b>	min. [°F]	-	-	-										-
	max. [°F]	-	-	-										-

<b>Body material: 0.7043 (ductile Gr. 60-40-18)</b>													
<b>DIN Flange</b>	Inlet	-	-	<b>PN 40</b>							<b>PN 16</b>		<b>PN 25</b>
	Outlet	-	-	<b>PN 16</b>							<b>PN 16</b>		<b>PN 10</b>
<b>Minimum set pressure</b>	p [psig] S/G/L	-	-	1.5	1.5	1.5	1.5	1.5	1.5	1.5	1.5	1.5	1.5
<b>Min. set pressure<sup>1)</sup> standard bellows</b>	p [psig] S/G/L	-	-	43.5	43.5	43.5	43.5	43.5	43.5	39.7	29.1	2.9	2.9
<b>Min. set pressure low press. bellows</b>	p [psig] S/G/L	-	-	14	20	16	26	22	15	17	20	-	-
<b>Maximum set pressure</b>	p [psig] S/G/L	-	-	580	580	580	580	580	464	580	232	232	290
<b>Max. set pressure with special spring</b>	p [psig] S/G/L	-	-	580	580	580	580	580	580	580	232	232	363
<b>Temperature acc. to DIN EN</b>	min. [°F]	-	-	-							-76		
	max. [°F]	-	-	-							+662		
<b>Temperature acc. to ASME</b>	min. [°F]	-	-	-							+14		
	max. [°F]	-	-	-							+662		

<sup>1)</sup> Min. set pressure standard bellows = Max. set pressure low pressure bellows.

## Type 441, 442 DIN

### Pressure temperature ratings

#### US Units

DN <sub>i</sub>	20	20	25	32	40	50	65	80	100	125	150	200
DN <sub>o</sub>	32	40	40	50	65	80	100	125	150	200	250	300
Actual Orifice diameter d <sub>o</sub> [inch]	0.71	0.71	0.91	1.14	1.46	1.81	2.36	2.91	3.62	3.86	4.92	6.5
Actual Orifice area A <sub>o</sub> [inch <sup>2</sup> ]	0.394	0.394	0.644	1.024	1.667	2.576	4.383	6.666	1.304	11.691	19.021	33.142

#### Body material: 1.0619 (WCB)

DIN Flange	Inlet		PN 40										PN 25	
	Outlet		PN 16											
<b>Minimum set pressure</b>	p [psig]	S/G/L	-	1.5	1.5	1.5	1.5	1.5	1.5	1.5	1.5	1.5	1.5	1.5
<b>Min. set pressure<sup>1)</sup> standard bellows</b>	p [psig]	S/G/L	-	43.5	43.5	43.5	43.5	43.5	43.5	43.5	39.7	29.1	2.9	2.9
<b>Min. set pressure low press. bellows</b>	p [psig]	S/G/L	-	29	14	20	16	26	22	15	17	20	-	-
<b>Maximum set pressure</b>	p [psig]	S/G/L	-	580	580	580	580	580	580	464	580	406	247	290
<b>Max. set pressure with special spring</b>	p [psig]	S/G/L	-	580	580	580	580	580	580	580	580	406	363	363
<b>Temperature<sup>2)</sup> acc. to DIN EN</b>	min. [°F]		-121											
	max. [°F]		+842											
<b>Temperature<sup>2)</sup> acc. to ASME</b>	min. [°F]		-20											
	max. [°F]		+800											

#### Body material: 1.4408 (CF8M)

DIN Flange	Inlet		PN 40										-	
	Outlet		PN 16										-	
<b>Minimum set pressure</b>	p [psig]	S/G/L	-	-	1.5	1.5	1.5	1.5	1.5	1.5	1.5	1.5	1.5	-
<b>Min. set pressure<sup>1)</sup> standard bellows</b>	p [psig]	S/G/L	-	-	43.5	43.5	43.5	43.5	43.5	43.5	39.7	29.1	2.9	-
<b>Min. set pressure low press. bellows</b>	p [psig]	S/G/L	-	-	14	20	16	26	22	15	17	20	-	-
<b>Maximum set pressure</b>	p [psig]	S/G/L	-	-	580	580	580	479	406	197	290	257	102	-
<b>Max. set pressure with special spring</b>	p [psig]	S/G/L	-	-	580	580	580	537	406	363	377	348	145	-
<b>Temperature<sup>2)</sup> acc. to DIN EN</b>	min. [°F]		-454											
	max. [°F]		+752											
<b>Temperature<sup>2)</sup> acc. to ASME</b>	min. [°F]		-450											
	max. [°F]		+1000											

<sup>1)</sup> Min. set pressure standard bellows = Max. set pressure low pressure bellows.

<sup>2)</sup> Between -10 °C and lowest temperature indicated „AD 2000-Merkblatt“ W10 shall be taken into account.

## Type 441, 442 DIN Flange drillings

	DN <sub>i</sub>	20	20	25	32	40	50	65	80	100	125	150	200	
	DN <sub>o</sub>	32	40	40	50	65	80	100	125	150	200	250	300	
	Valve size	–	3/4" x 1 1/2"	1" x 1 1/2"	1 1/4" x 2"	1 1/2" x 2 1/2"	2" x 3"	2 1/2" x 4"	3" x 5"	4" x 6"	5" x 8"	6" x 10"	8" x 12"	
	Actual Orifice diameter d <sub>o</sub> [mm]	18	18	23	29	37	46	60	74	92	98	125	165	
	Actual Orifice area A <sub>o</sub> [mm <sup>2</sup> ]	254	254	416	661	1075	1662	2827	4301	6648	7543	12272	21382	
<b>Body material: 0.6025 (cast iron)</b>														
Inlet	DIN EN 1092	PN 10	*	*	*	*	*	*	*	*	*	*	*	
		PN 16	*	*	*	*	*	*	*	*	*	*	*	
		PN 25	–	–	–	–	–	–	–	–	–	–	–	
		PN 40	–	–	–	–	–	–	–	–	–	–	–	
Outlet	DIN EN 1092	PN 10	*	*	*	*	*	*	*	*	H50	H50		
		PN 16	*	*	*	*	*	*	*	*	*	*	*	
		PN 25	–	–	–	–	–	–	–	–	–	–	–	
		PN 40	–	–	–	–	–	–	–	–	–	–	–	
<b>Body material: 0.7043 (ductile Gr. 60-40-18)</b>														
Inlet	DIN EN 1092	PN 10		*	*	*	*	H45	*	H45	*	*	H44	
		PN 16		*	*	*	*	*	*	*	*	*	H45	
		PN 25		*	*	*	*	*	*	*	*	–	–	*
		PN 40		*	*	*	*	*	*	*	*	–	–	–
Outlet	DIN EN 1092	PN 10		*	*	*	*	*	*	*	H50	H50	*	
		PN 16		*	*	*	*	*	*	*	*	*	(H51)	
		PN 25		*	(*)	(H15)	(*)	–	–	–	–	–	–	
		PN 40		*	(*)	(H15)	(*)	–	–	–	–	–	–	
<b>Body material: 1.0619 (WCB), 1.4408 (CF8M)</b>														
Inlet	DIN EN 1092	PN 10	*	*	*	*	*	H45	H45	H45	H45	H45	H44	
		PN 16	*	*	*	*	*	H45	H45	H45	H45	H45	H44	
		PN 25	*	*	*	*	*	*	*	*	*	*	*	
		PN 40	*	*	*	*	*	*	*	*	*	*	*	
	ASME B16.5 <sup>1)</sup>	CL150	H64	H64	H64	H64	H64	H64	H64	H64	[H64]	H64	H64	H64
		CL300	–	–	H65	–	[H65]	–	–	–	–	–	–	
Outlet	DIN EN 1092	PN 10	*	*	*	*	*	*	*	*	H50	H50	H50	
		PN 16	*	*	*	*	*	*	*	*	*	*	*	
		PN 25	*	*	*	(H15)	(*)	–	–	–	–	–	H52	
		PN 40	*	*	*	(H15)	(*)	–	–	–	–	–	H52	
	ASME B16.5 <sup>1)</sup>	CL150	H79	H79	H79	H79	H79	[H79]	H79	H79	H79	H79	H79	H79
		CL300	–	–	[H80]	–	–	–	–	–	–	–	–	

Note: Flange drillings and facings meet always the requirements of mentioned flange standards.  
Flange thickness and outer diameter may vary from flange standard.

<sup>1)</sup>For flange drillings acc. to ASME B16.5 please use preferred Type 441, 442 ANSI.

## Type 441, 442 DIN

### Flange facings

 Type 441, 442  
DIN

Indication	Norm	Inlet	Outlet	Remark
<b>General</b>				
Flange undrilled	–	H38	H39	
Linde-V-Nut, Form V48	Linde Standard 420-08	J07	J08	Groove: Rz 16
Linde-V-Nut, Form V48A	LDeS 3313.36	J05	J06	Groove: Rz 4, e.g. with hydrogen
Lens seal form L (without sealing lens)	DIN 2696 LDeS 3313.35	J11	J12	

Acc. to DIN EN 1092				
		Inlet	Outlet	Remark
<b>Flange facing</b> (see LDeS 3313.40)		PN 10 – PN 40	PN 10 – PN 40	Rz-data according to DIN EN 1092 in µm
Raised face	Type B1	*	*	Facing: Rz = 12.5 – 50
	Type B2	L36	L38	Facing: Rz = 3.2 – 12.5
Tongue face C <sup>1)</sup>		H94	H92	Steel flange only
Groove face D <sup>1)</sup>		H93	H91	
Male face E		H96	H98	
Female face F		H97	H99	
O-ring male face G		J01	J02	
O-ring female face H		J03	J04	

Acc. to ASME B16.5										
Body material	Inlet	Outlet	Smooth finish <sup>2)</sup>		Serrated finish		RTJ-groove			
			Inlet	Outlet	Inlet	Outlet	Inlet		Outlet	
			Option code		Option code		RTJ- Class	Option code	RTJ- Class	Option code
1.0619, 1.4408	all	all	L52	L53	*	*	CL150	H62	CL150	H63

<sup>1)</sup> LESER manufactures the groove at flanged valves by milling. If a customer demands a turned surface in the soil of the groove according to DIN EN 1092-1 an additional option code is necessary: "S01: soil of the groove drilled".

<sup>2)</sup> Smooth finish is not defined in the effective standards.

Note: Flange drillings and facings meet always the requirements of mentioned flange standards.  
Flange thickness and outer diameter may vary from flange standard.

## Change of nominal diameter with welding flange

Designation	Material	DN / NPS		
Type 441 DIN		<b>32</b>	<b>40</b>	<b>80</b>
Change nominal diameter inlet to DN 40 / NPS 1½"	1.0619 (WCB)	I28	–	–
	1.4408 (CF8M)	I28	–	–
Change nominal diameter outlet to DN 80 / NPS 3"	1.0619 (WCB)	–	I29	–
	1.4408 (CF8M)	–	I29	–
Change nominal diameter outlet to DN 150 / NPS 6"	1.0619 (WCB)	–	–	I30
	1.4408 (CF8M)	–	–	I30



**Type 442 ANSI**  
Plain lever H3  
Open bonnet  
Conventional design

**Type 441, 442 ANSI**  
**Flanged Safety Relief Valves**

<b>Contents</b>	<b>Page</b>
<b>Materials</b>	
• Conventional design	22
• Balanced bellows design	24
<b>Article numbers</b>	26
<b>Dimensions and weights</b>	
• Metric Units	27
• US Units	28
<b>Pressure temperature ratings</b>	
• Metric Units	29
• US Units	30
Flange drillings and facings	31
<b>Series 441, Series 441 Full nozzle</b>	
Approvals	48
Available options	49
LESER Original Spare Parts Kits	50



**Type 441 ANSI**  
Packed lever H4  
Closed bonnet  
Conventional design

**Type 441, 442 ANSI**  
**Conventional design**

Type 441, 442  
ANSI

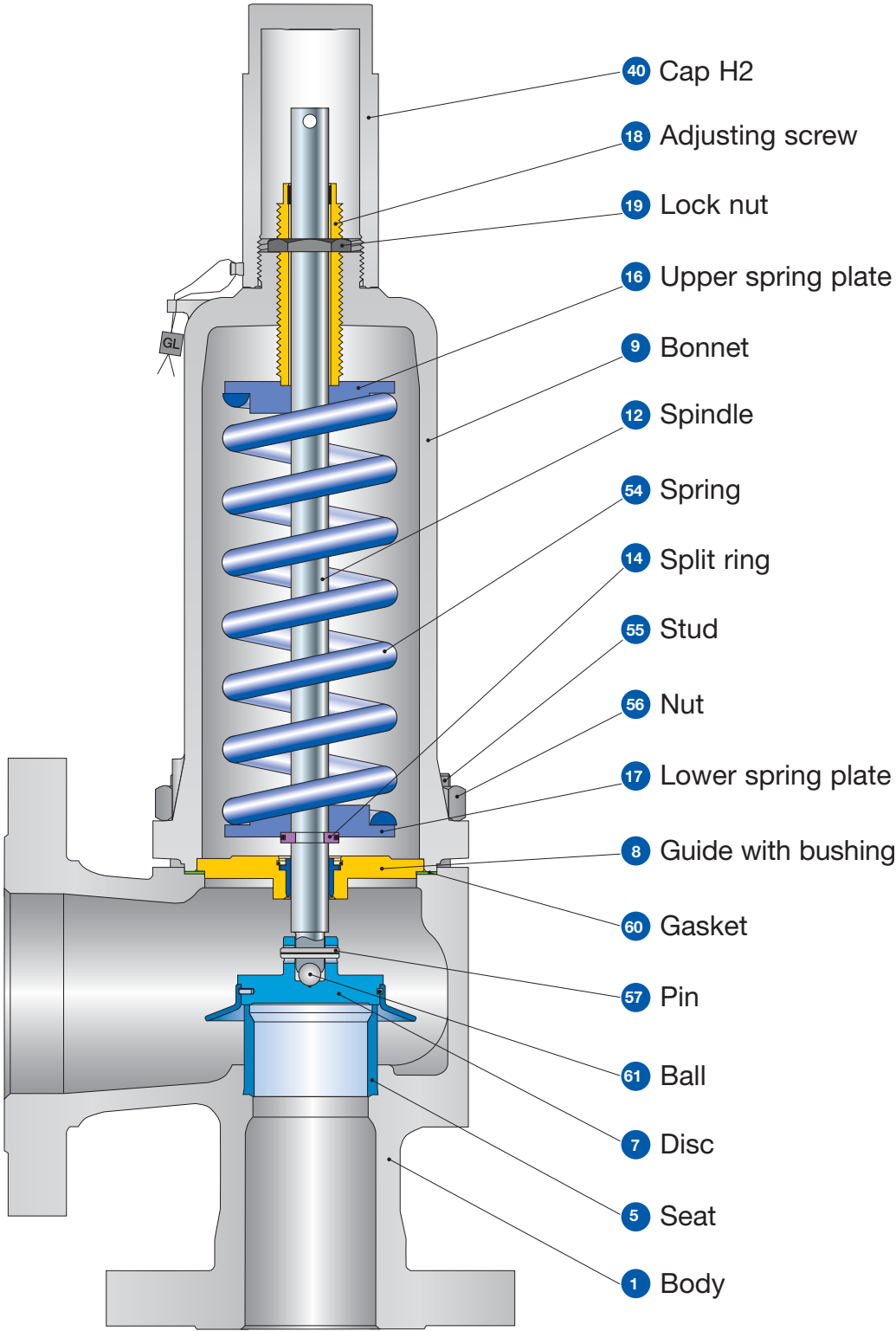

## Type 441, 442 ANSI

### Conventional design

#### Materials

Item	Component	Type 4412 / 4422 ANSI	Type 4414 ANSI
1	Body	1.0619	1.4408
		SA 216 WCB	SA 351 CF8M
5	Seat	1.4404	1.4404
		316L	316L
7	Disc	1.4122	1.4404
		Hardened stainless steel	316L
8	Guide with bushing	1.4104, 1.0501, 0.7040	1.4404
		Chrome or carbon steel	316L
		1.4104 tenifer	-
		Chrome steel tenifer	-
9	Bonnet	0.7040, 0.7043, 1.0619	1.4408, 1.4404, 1.4571
		Ductile Gr. 60-40-18, SA 216 WCB	SA 351 CF8M, SA 479 316L, SA 479 316Ti
12	Spindle	1.4021	1.4404
		420	316L
14	Split ring	1.4104	1.4404
		Chrome steel	316L
16 / 17	Spring plate	1.0718	1.4404
		Steel	316L
18	Adjusting screw with bushing	1.4104 PTFE	1.4404 PTFE
		Chrome steel PTFE	316L PTFE
19	Lock nut	1.0718	1.4404
		Steel	316L
40	Cap H2	1.0460 or 0.7043	1.4404
		SA 105 or Gr. 60-40-18	316L
54	Spring standard	1.1200, 1.8159, 1.7102	1.4310
		Carbon steel	Stainless steel
54	Spring optional	1.4310	-
		Stainless steel	-
55	Stud	1.1181	1.4401
		Steel	B8M
56	Nut	1.0501	1.4401
		2H	8M
57	Pin	1.4310	1.4310
		Stainless steel	Stainless steel
60	Gasket	Graphite / 1.4401	Graphite / 1.4401
		Graphite / 316	Graphite / 316
61	Ball	1.3541	1.4401
		Hardened stainless steel	316

**Please notice:**

- Modifications reserved by LESER
- If several materials are specified LESER defines the material.
- LESER can upgrade materials without notice.
- Every part can be replaced by other material acc. to customer specification.

**Type 441, 442 ANSI**  
**Balanced bellows design**

Type 441, 442  
 ANSI

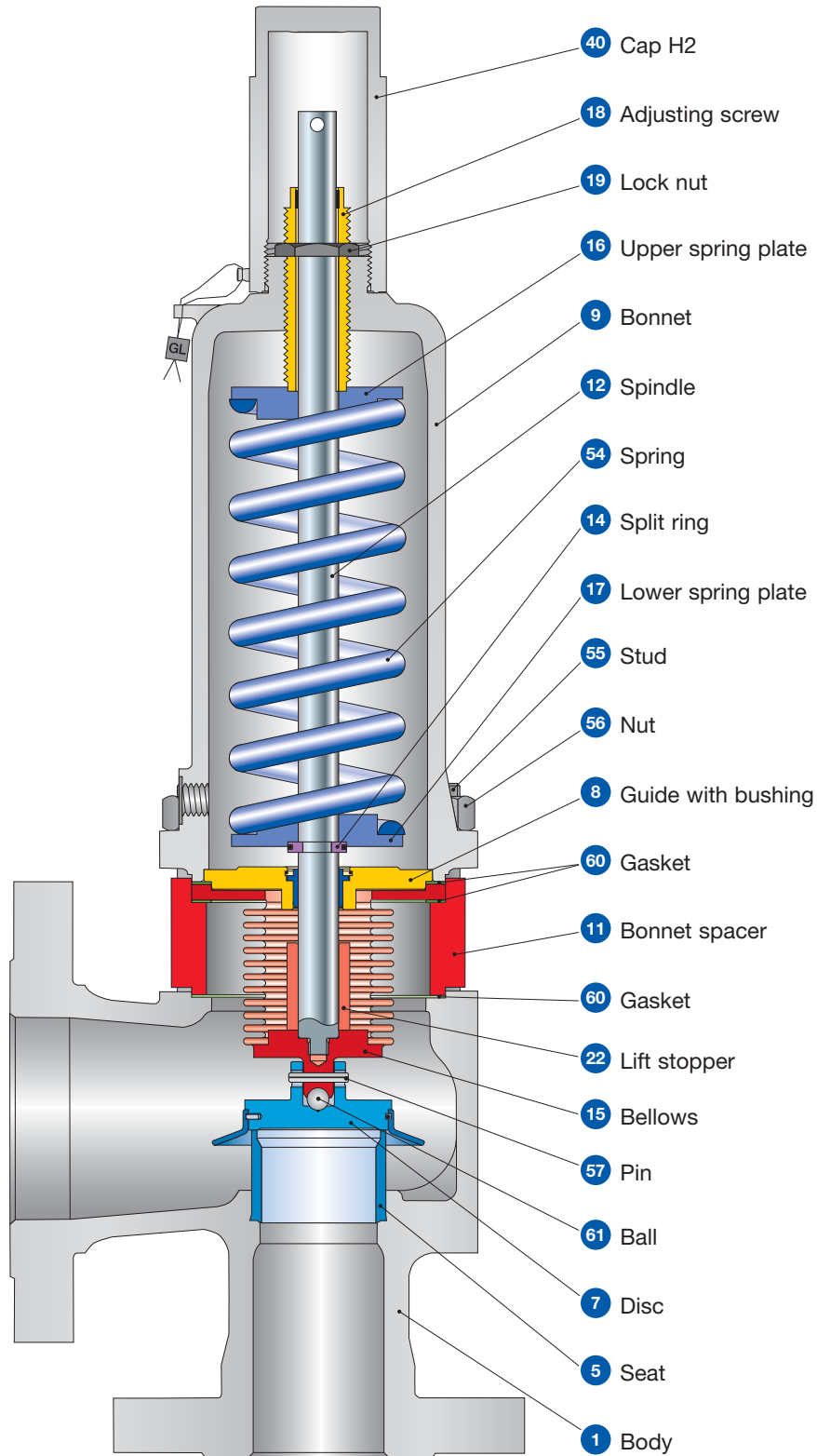



## Type 441, 442 ANSI

### Balanced bellows design

#### Materials

Item	Component	Type 4412 / 4422 ANSI	Type 4414 ANSI
1	Body	1.0619	1.4408
		SA 216 WCB	SA 351 CF8M
5	Seat	1.4404	1.4404
		316L	316L
7	Disc	1.4122	1.4404
		Hardened stainless steel	316L
8	Guide with bushing	1.4104, 1.0501, 0.7040	1.4404
		Chrome steel or carbon steel	316L
		1.4104 tenifer	-
		Chrome steel tenifer	-
9	Bonnet	0.7040, 0.7043, 1.0619	1.4408, 1.4404, 1.4571
		Ductile Gr. 60-40-18, SA 216 WCB	SA 351 CF8M, SA 479 316L, SA 479 316Ti
11	Bonnet spacer	1.4404	1.4404
		316L	316L
12	Spindle	1.4404	1.4404
		316L	316L
14	Split ring	1.4104	1.4404
		Chrome steel	316L
15	Bellows	1.4571	1.4571
		316Ti	316Ti
16 / 17	Spring plate	1.0718	1.4404
		Steel	316L
18	Adjusting screw with bushing	1.4104 PTFE	1.4404 PTFE
		Chrome steel PTFE	316L PTFE
19	Lock nut	1.0718	1.4404
		Steel	316L
22	Lift stopper	1.4404	1.4404
		316L	316L
40	Cap H2	1.0460 or 0.7043	1.4404
		SA 105 or Gr. 60-40-18	316L
54	Spring standard	1.1200, 1.8159, 1.7102	1.4310
		Carbon steel	Stainless steel
54	Spring optional	1.4310	-
		Stainless steel	-
55	Stud	1.4401	1.4401
		B8M	B8M
56	Nut	1.4401	1.4401
		8M	8M
57	Pin	1.4310	1.4310
		Stainless steel	Stainless steel
60	Gasket	Graphite / 1.4401	Graphite / 1.4401
		Graphite / 316	Graphite / 316
61	Ball	1.3541	1.4401
		Hardened stainless steel	316

**Please notice:**

- Modifications reserved by LESER
- If several materials are specified LESER defines the material.
- LESER can upgrade materials without notice.
- Every part can be replaced by other material acc. to customer specification.

**Type 441, 442 ANSI**  
**Article numbers**

Type 441, 442  
ANSI

Valve size			1" x 2"	1½" x 2"	1½" x 2½"	2" x 3"	3" x 4"	4" x 6"
Actual Orifice diameter $d_o$ [mm]			23	29	37	46	60	92
Actual Orifice area $A_o$ [mm <sup>2</sup> ]			416	661	1075	1662	2827	6648
<b>Body material: 1.0619 (WCB)</b>								
<b>Bonnet</b> closed	<b>H2</b>	Art. No. <b>4412.</b>	<b>4812</b>	<b>4822</b>	<b>4832</b>	<b>4842</b>	<b>4862</b>	<b>4872</b>
	<b>H3</b>	Art. No. <b>4412.</b>	<b>4813</b>	<b>4823</b>	<b>4833</b>	<b>4843</b>	<b>4863</b>	<b>4873</b>
	<b>H4</b>	Art. No. <b>4412.</b>	<b>4814</b>	<b>4824</b>	<b>4834</b>	<b>4844</b>	<b>4864</b>	<b>4874</b>
open	<b>H3</b>	Art. No. <b>4422.</b>	<b>4815</b>	<b>4825</b>	<b>4835</b>	<b>4845</b>	<b>4865</b>	<b>4875</b>
<b>Body material: 1.4408 (CF8M)</b>								
<b>Bonnet</b> closed	<b>H2</b>	Art. No. <b>4414.</b>	<b>7912</b>	–	<b>7932</b>	<b>7942</b>	<b>7962</b>	<b>7972</b>
	<b>H4</b>	Art. No. <b>4414.</b>	<b>7914</b>	–	<b>7934</b>	<b>7944</b>	<b>7964</b>	<b>7974</b>

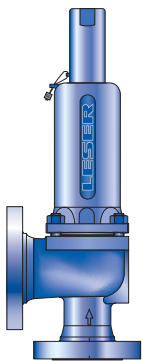

**Type 441**  
 Cap H2  
 Closed bonnet  
 Conventional design

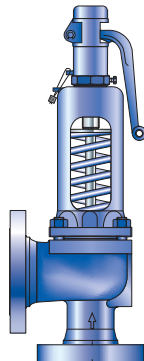

**Type 442**  
 Plain lever H3  
 Bonnet open  
 Conventional design

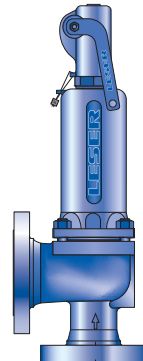

**Type 441**  
 Packed lever H4  
 Closed bonnet  
 Conventional design

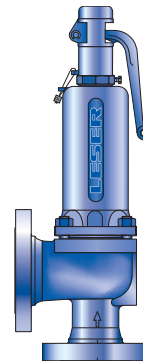

**Type 441**  
 Plain lever H3  
 Closed bonnet  
 Conventional design

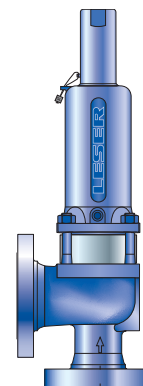

**Type 441**  
 Cap H2  
 Closed bonnet  
 Balanced bellows design

## Type 441, 442 ANSI

### Dimensions and weights

Metric Units

Valve size	1" x 2"	1½" x 2"	1½" x 2½"	2" x 3"	3" x 4"	4" x 6"
Actual Orifice diameter $d_o$ [mm]	23	29	37	46	60	92
Actual Orifice area $A_o$ [mm <sup>2</sup> ]	416	661	1075	1662	2827	6648
<b>Weight</b> [kg]	10	13	16	22	33	75
with bellows	11	14	17	24	37	83
<b>Center to face</b> [mm]						
Inlet a	105	124	124	136	156	181
Outlet b	114	121	121	124	165	229
<b>Height (H4)</b> [mm]						
Standard H max.	339	455	496	556	685	844
Bellows H max.	378	497	534	602	741	902
<b>Support brackets</b> [mm]						
A						280
B						160
(drilled only on request, option code H42)						Ø 18
C						250
D						25
E						

Type 441, 442  
ANSI

#### Body material: 1.0619 (WCB)

<b>ANSI Flange Class<sup>1)</sup></b>	Inlet	CL150 or CL300
	Outlet	CL150

#### Body material: 1.4408 (CF8M)

<b>ANSI Flange Class<sup>1)</sup></b>	Inlet	CL150 or CL300	-	CL150 or CL300
	Outlet	CL150	-	CL150

<sup>1)</sup>Standard flange rating. For other flange drillings and facings please refer to page 31.

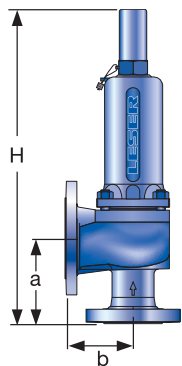

Conventional design

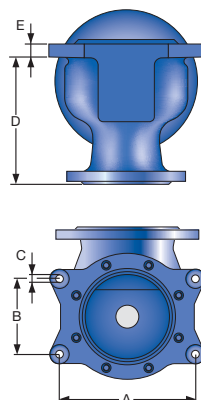

Support brackets

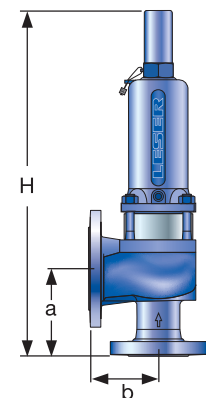

Balanced bellows design

## Type 441, 442 ANSI

### Dimensions and weights

US Units

Type 441, 442  
ANSI

Valve size	1" x 2"	1½" x 2"	1½" x 2½"	2 x 3"	3 x 4"	4 x 6"
Actual Orifice diameter $d_0$ [inch]	0.91	1.14	1.46	1.81	2.36	3.62
Actual Orifice area $A_0$ [inch <sup>2</sup> ]	0.644	1.024	1.667	2.576	4.383	10.304
<b>Weight</b> [lbs]	22	29	35	49	73	165
with bellows	23	30	38	52	81	183
<b>Center to face</b> [inch]						
Inlet a	4 1/8	4 7/8	4 7/8	5 3/8	6 1/8	7 1/8
Outlet b	4 1/2	4 3/4	4 3/4	4 7/8	6 1/2	9
<b>Height (H4)</b> [inch]						
Standard H max.	13 11/32	17 29/32	19 17/32	21 1/16	26 31/32	33 7/32
Bellows H max.	14 7/8	19 9/16	21 1/32	23 11/16	29 3/16	35 1/2
<b>Support brackets</b> [inch]						
A						11
B						6 1/4
(drilled only on request, option code H42)						Ø 3/4
D						9 7/8
E						25

#### Body material: 1.0619 (WCB)

<b>ANSI Flange Class<sup>1)</sup></b>	Inlet	CL150 or CL300
	Outlet	CL150

#### Body material: 1.4408 (CF8M)

<b>ANSI Flange Class<sup>1)</sup></b>	Inlet	CL150 or CL300	-	CL150 or CL300
	Outlet	CL150	-	CL150

<sup>1)</sup>Standard flange rating. For other flange drillings and facings please refer to page 31.

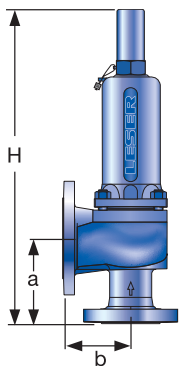

Conventional design

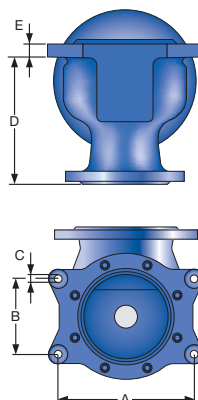

Support brackets

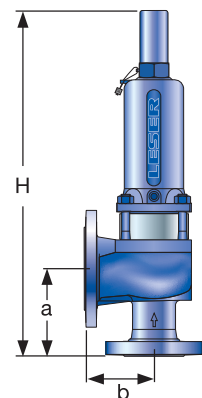

Balanced bellows design

## Type 441, 442 ANSI

### Pressure temperature ratings

#### Metric Units

Valve size		1" x 2"	1½" x 2"	1½" x 2½"	2 x 3"	3 x 4"	4 x 6"
Actual Orifice diameter $d_o$ [mm]		23	29	37	46	60	92
Actual Orifice area $A_o$ [mm <sup>2</sup> ]		416	661	1075	1662	2827	6648
<b>Body material: 1.0619 (WCB)</b>							
ANSI Flange Class <sup>1)</sup>	Inlet	CL150 or CL300					
	Outlet	CL150					
<b>Minimum set pressure</b>	p [bar <sub>g</sub> ] S/G/L	0.1	0.1	0.1	0.1	0.1	0.1
<b>Min. set pressure<sup>2)</sup> standard bellows</b>	p [bar <sub>g</sub> ] S/G/L	3	3	3	3	3	3
<b>Min. set pressure low press. bellows</b>	p [bar <sub>g</sub> ] S/G/L	0.98	1.41	1.11	1.81	1.50	1.18
<b>Maximum set pressure</b>	p [bar <sub>g</sub> ] S/G/L	49	48	46	40 <sup>4)</sup>	40	34
<b>Max. set pressure with special spring</b>	p [bar <sub>g</sub> ] S/G/L	51	48	46	40 <sup>4)</sup>	40	34
<b>Temperature<sup>3)</sup> acc. to DIN EN</b>	min. [°C]	-85					
	max. [°C]	+450					
<b>Temperature<sup>3)</sup> acc. to ASME</b>	min. [°C]	-29					
	max. [°C]	+427					

<b>Body material: 1.4408 (CF8M)</b>							
ANSI Flange Class <sup>1)</sup>	Inlet	CL150 or CL300	–	CL150 or CL300			
	Outlet	CL150	–	CL150			
<b>Minimum set pressure</b>	p [bar <sub>g</sub> ] S/G/L	0.1	–	0.1	0.1	0.1	0.1
<b>Min. set pressure<sup>2)</sup> standard bellows</b>	p [bar <sub>g</sub> ] S/G/L	3	–	3	3	3	3
<b>Min. set pressure low press. bellows</b>	p [bar <sub>g</sub> ] S/G/L	0.98	–	1.11	1.81	1.50	1.18
<b>Maximum set pressure</b>	p [bar <sub>g</sub> ] S/G/L	42.5	–	40	32	27	20
<b>Max. set pressure with special spring</b>	p [bar <sub>g</sub> ] S/G/L	51	–	40	40	27	25
<b>Temperature<sup>3)</sup> acc. to DIN EN</b>	min. [°C]	-270	–	-270			
	max. [°C]	+400	–	+400			
<b>Temperature<sup>3)</sup> acc. to ASME</b>	min. [°C]	-268	–	-268			
	max. [°C]	+538	–	+538			

<sup>1)</sup> For flange rating class 150 the pressure temperature ratings according to ASME ANSI B 16.34 apply.

<sup>2)</sup> Min. set pressure standard bellows = Max. set pressure low pressure bellows.

<sup>3)</sup> Between -10 °C and lowest temperature indicated „AD 2000-Merkblatt“ W10 shall be taken into account.

<sup>4)</sup> For applications with CE marking. Maximum set pressure for ASME application 49 bar.

## Type 441, 442 ANSI

### Pressure temperature ratings

#### US Units

 Type 441, 442  
ANSI

Valve size		1" x 2"	1 1/2" x 2"	1 1/2" x 2 1/2"	2 x 3"	3 x 4"	4 x 6"	
Actual Orifice diameter d <sub>0</sub> [inch]		0.91	1.14	1.46	1.81	2.36	3.62	
Actual Orifice area A <sub>0</sub> [inch <sup>2</sup> ]		0.644	1.024	1.667	2.576	4.383	1.304	
<b>Body material: 1.0619 (WCB)</b>								
ANSI Flange Class <sup>1)</sup>	Inlet		CL150 or CL300					
	Outlet		CL150					
<b>Minimum set pressure</b>	p [psig] S/G/L	1.5	1.5	1.5	1.5	1.5	1.5	
<b>Min. set pressure<sup>2)</sup> standard bellows</b>	p [psig] S/G/L	43.5	43.5	43.5	43.5	43.5	43.5	
<b>Min. set pressure low press. bellows</b>	p [psig] S/G/L	14	20	16	26	22	17	
<b>Maximum set pressure</b>	p [psig] S/G/L	711	696	667	580 <sup>4)</sup>	580	493	
<b>Max. set pressure with special spring</b>	p [psig] S/G/L	740	696	667	580 <sup>4)</sup>	580	493	
<b>Temperature<sup>3)</sup> acc. to DIN EN</b>	min. [°F]						-121	
	max. [°F]						+842	
<b>Temperature<sup>3)</sup> acc. to ASME</b>	min. [°F]						-20	
	max. [°F]						+800	

<b>Body material: 1.4408 (CF8M)</b>								
ANSI Flange Class <sup>1)</sup>	Inlet		CL150 or CL300	-	CL150 or CL300			
	Outlet		CL150	-	CL150			
<b>Minimum set pressure</b>	p [psig] S/G/L	1.5	-	1.5	1.5	1.5	1.5	
<b>Min. set pressure<sup>2)</sup> standard bellows</b>	p [psig] S/G/L	43.5	-	43.5	43.5	43.5	43.5	
<b>Min. set pressure low press. bellows</b>	p [psig] S/G/L	14	-	16	26	22	17	
<b>Maximum set pressure</b>	p [psig] S/G/L	616	-	580	464	392	290	
<b>Max. set pressure with special spring</b>	p [psig] S/G/L	740	-	580	580	392	363	
<b>Temperature<sup>3)</sup> acc. to DIN EN</b>	min. [°F]	-454	-					-454
	max. [°F]	+752	-					+752
<b>Temperature<sup>3)</sup> acc. to ASME</b>	min. [°F]	-450	-					-450
	max. [°F]	+1000	-					+1000

<sup>1)</sup> For flange rating class 150 the pressure temperature ratings according to ASME ANSI B 16.34 apply.

<sup>2)</sup> Min. set pressure standard bellows = Max. set pressure low pressure bellows.

<sup>3)</sup> Between -10 °C and lowest temperature indicated „AD 2000-Merkblatt“ W10 shall be taken into account.

<sup>4)</sup> For applications with CE marking. Maximum set pressure for ASME application 711 psig.

## Type 441, 442 ANSI Flange drillings

Valve size		1" x 2"	1½" x 2"	1½" x 2½"	2" x 3"	3" x 4"	4" x 6"
Actual Orifice diameter d <sub>0</sub> [mm]		23	29	37	46	60	92
Actual Orifice area A <sub>0</sub> [mm <sup>2</sup> ]		416	661	1075	1662	2827	6648
<b>Body material: 1.0619 (WCB), 1.4408 (CF8M)</b>							
Inlet	ASME B16.5	CL150	H64	H64	H64	H64	H64
		CL300	*	*	*	*	*
Outlet	ASME B16.5	CL150	*	*	*	*	*
		CL300	-	-	-	-	-

 Type 441, 442  
ANSI

## Flange facings

Indication	Standard	Inlet	Outlet	Remark						
<b>General</b>										
Flange undrilled	-	H38	H39							
Linde-V-Nut, Type V48	Linde Standard 420-08	J07	J08	Groove: Rz 16						
Linde-V-Nut, Type V48A	LDeS 3313.36	J05	J06	Groove: Rz 4, e.g. with hydrogen						
Lens seal form L (without sealing lens)	DIN 2696 LDeS 3313.35	J11	J12							
<b>Acc. to DIN EN 1092</b>										
		<b>Inlet</b>	<b>Outlet</b>	<b>Remark</b>						
	<b>Flange facing</b> (see LDeS 3313.40)	PN 10 – PN 40	PN 10 – PN 40	Rz-data according to DIN EN 1092 in µm						
Raised face	Type B1	*	*	Facing: Rz = 12.5 – 50						
	Type B2	L36	L38	Facing: Rz = 3.2 – 12.5						
Tongue face C <sup>1)</sup>		H94	H92	Steel flange only						
Groove face D <sup>1)</sup>		H93	H91							
Male face E		H96	H98							
Female face F		H97	H99							
O-ring male face G		J01	J02							
O-ring female face H		J03	J04							
<b>Acc. to ASME B16.5</b>										
Body material	Inlet	Outlet	Smooth finish <sup>2)</sup>		Serrated finish		RTJ-groove			
			Inlet	Outlet	Inlet	Outlet	Inlet		Outlet	
			Option code		Option code		RTJ- Class	Option code	RTJ- Class	Option code
1.0619, 1.4408	all	all	L52	L53	*	*	CL150	H62	CL150	H63

<sup>1)</sup> LESER manufactures the groove at flanged valves by milling. If a customer demands a turned surface in the soil of the groove according to DIN EN 1092-1 an additional option code is necessary: "S01: soil of the groove drilled".

<sup>2)</sup> Smooth finish is not defined in the effective standards.

Note: Flange drillings and facings meet always the requirements of mentioned flange standards.  
Flange thickness and outer diameter may vary from flange standard.





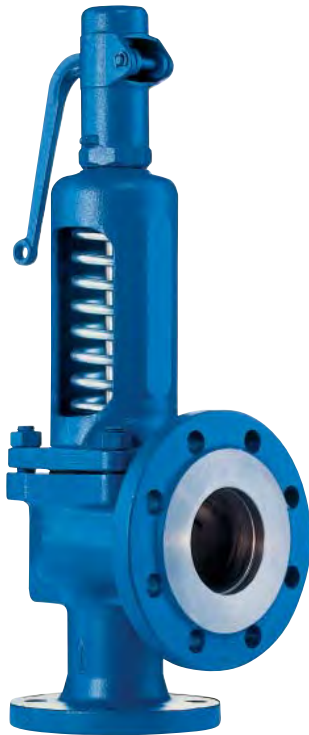

**Type 442 Full nozzle**  
Plain lever H3  
Bonnet open  
Conventional design



**Type 442 Full nozzle**  
Plain lever H3  
Bonnet open  
Conventional design

**Type 441, 442 Full nozzle DIN**  
**Type 441, 442 Full nozzle ANSI**  
**Flanged Safety Relief Valve**

Type 441, 442  
Full nozzle

<b>Contents</b>	<b>Page</b>
<b>Materials</b>	
• Conventional design	34
• Balanced bellows design	36
<b>Article numbers</b>	38
<b>Dimensions and weights</b>	
Type 441, 442 Full nozzle DIN	
• Metric Units + US Units	39
Type 441, 442 Full nozzle ANSI	
• Metric Units 40	
• US Units	41
<b>Pressure temperature ratings</b>	
Type 441, 442 Full nozzle DIN	
• Metric Units 42	
• US Units	43
Type 441, 442 Full nozzle ANSI	
• Metric Units 44	
• US Units	45
Flange drillings	46
Flange facings	47
<b>Series 441, Series 441 Full nozzle</b>	
Approvals	48
Available options	49
LESER Original Spare Parts Kits	50

**Type 441, 442 Full nozzle DIN, ANSI  
Conventional design**

Type 441, 442  
Full nozzle

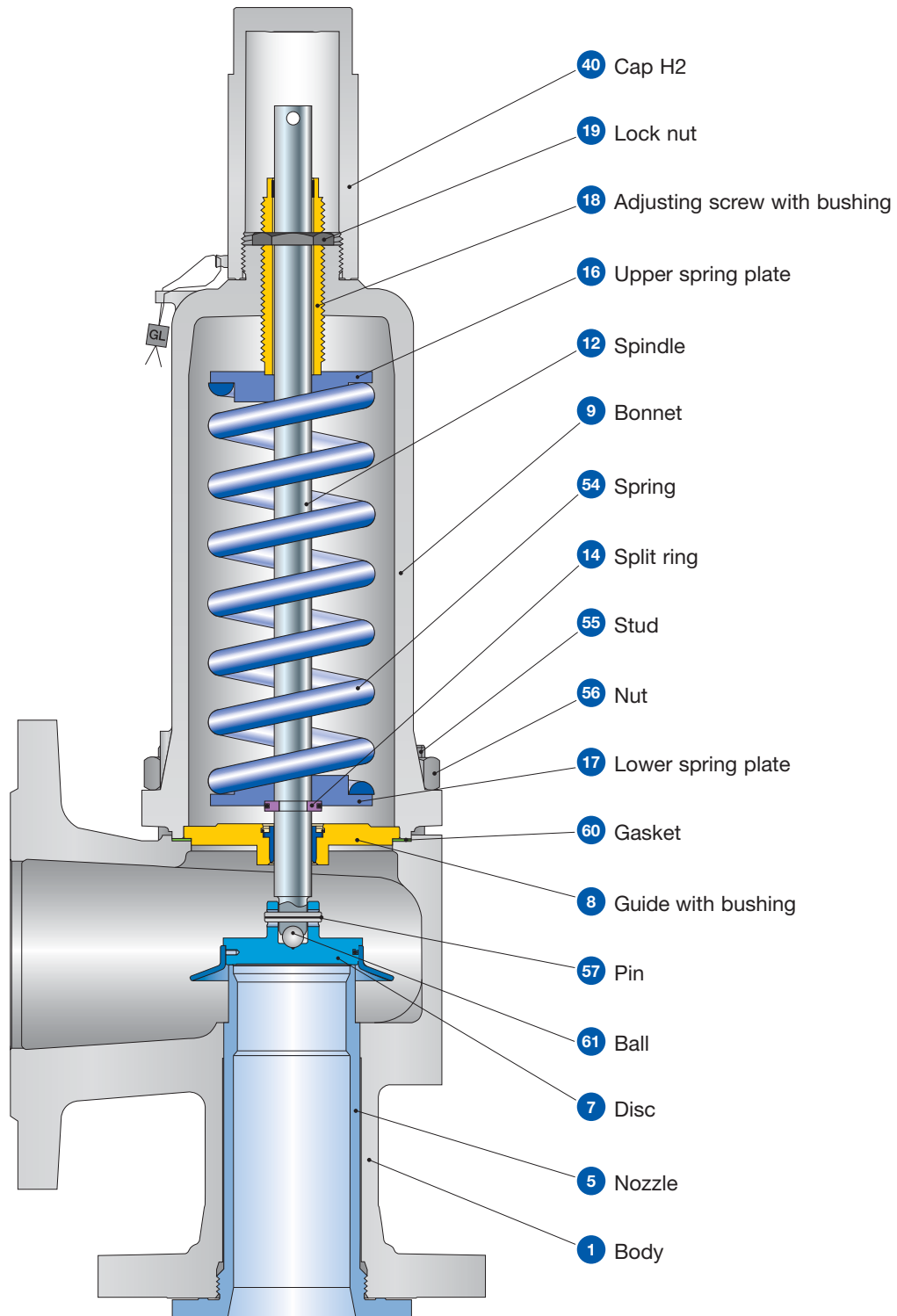

## Type 441, 442 Full nozzle DIN, ANSI

### Conventional design

#### Materials

Item	Component	Type 4412 / 4422 Full nozzle	Type 4414 Full nozzle
1	Body	1.0619	1.4408
		SA 216 WCB	SA 351 CF8M
5	Seat	1.4404	1.4404
		316L	316L
7	Disc	1.4122	1.4404
		Hardened stainless steel	316L
8	Guide with bushing	1.0501	1.4404
		Carbon steel	316L
		1.4104 tenifer	-
		Chrome steel tenifer	-
9	Bonnet	0.7040, 0.7043, 1.0619	1.4408 or 1.4571
		Ductile Gr. 60-40-18, SA 216 WCB	SA CF8M or SA 479 316Ti
12	Spindle	1.4021	1.4404
		420	316L
14	Split ring	1.4104	1.4404
		Chrome steel	316L
16 / 17	Spring plate	1.0718	1.4404
		12L13	316L
18	Adjusting screw with bushing	1.4104 PTFE	1.4404 PTFE
		Chrome steel PTFE	316L PTFE
19	Lock nut	1.0718	1.4404
		Steel	316L
40	Cap H2	1.0460	1.4404
		SA 105	316L
54	Spring standard	1.1200, 1.8159, 1.7102	1.4310
		Carbon steel	Stainless steel
	Spring optional	1.4310	-
55	Stud	1.1181	1.4401
		Steel	B8M
56	Nut	1.0501	1.4401
		2H	8M
57	Pin	1.4310	1.4310
		Stainless steel	Stainless steel
60	Gasket	Graphite / 1.4401	Graphite / 1.4401
		Graphite / 316	Graphite / 316
61	Ball	1.3541	1.4401
		Hardened stainless steel	316

**Please notice:**

- Modifications reserved by LESER
- If several materials are specified LESER defines the material.
- LESER can upgrade materials without notice.
- Every part can be replaced by other material acc. to customer specification.

**Type 441, 442 Full nozzle DIN, ANSI**  
**Balanced bellows design**

Type 441, 442  
 Full nozzle

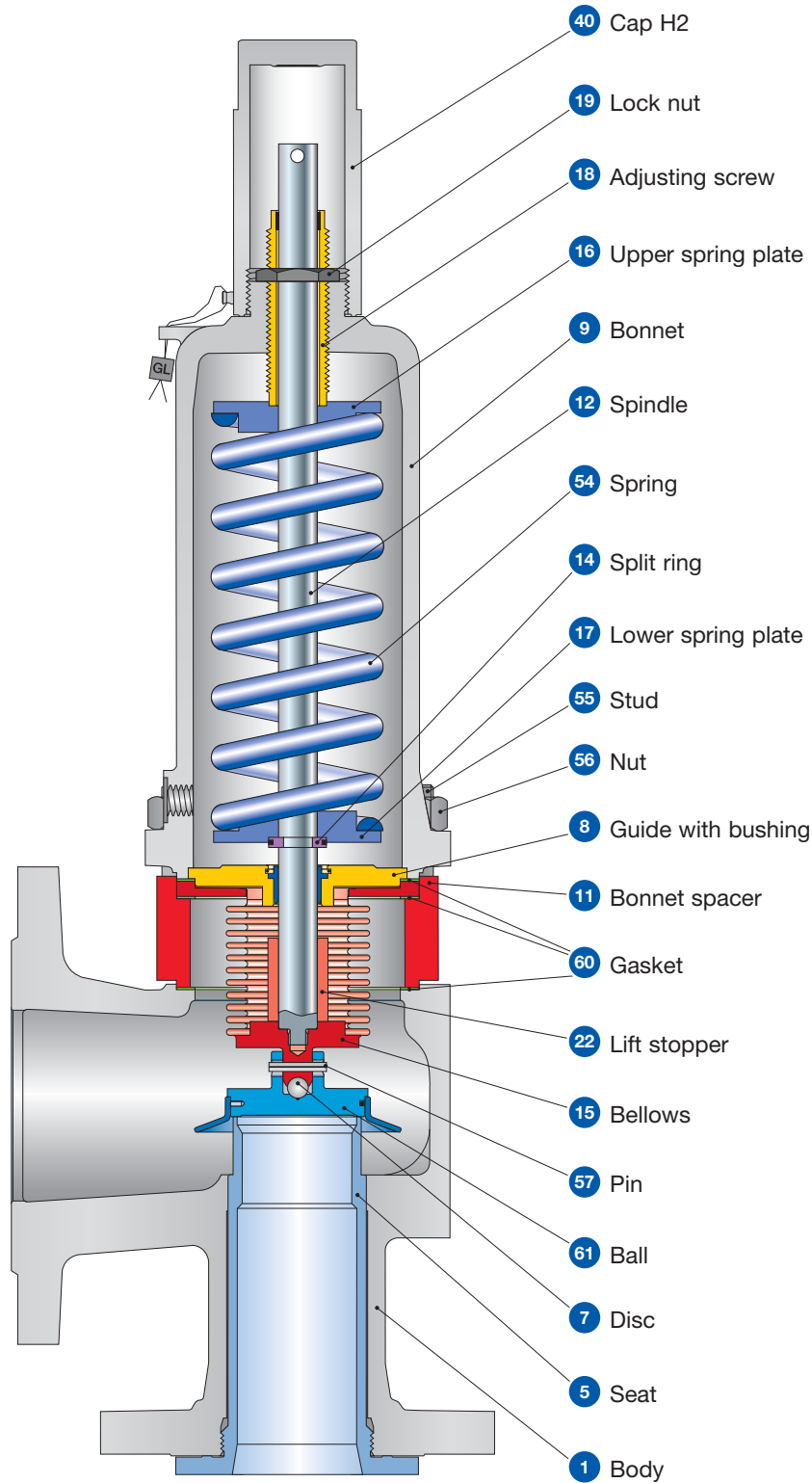

## Type 441, 442 Full nozzle DIN, ANSI

### Balanced bellows design

#### Materials

Item	Component	Type 4412 / 4422 Full nozzle	Type 4414 Full nozzle
1	Body	1.0619	1.4408
		SA 216 WCB	SA 351 CF8M
5	Seat	1.4404	1.4404
		316L	316L
7	Disc	1.4122	1.4404
		Hardened stainless steel	316L
8	Guide with bushing	1.0501	1.4404
		Carbon steel	316L
		1.4104 tenifer	-
		Chrome steel tenifer	-
9	Bonnet	0.7040, 0.7043, 1.0619	1.4408 or 1.4571
		Ductile Gr. 60-40-18, SA 216 WCB	SA 351 CF8M or SA 479 316Ti
11	Bonnet spacer	1.0460	1.4404
		Carbon steel	316L
12	Spindle	1.4404	1.4404
		316L	316L
14	Split ring	1.4104	1.4404
		Chrome steel	316L
15	Bellows	1.4571	1.4571
		316Ti	316Ti
16 / 17	Spring plate	1.0718	1.4404
		Steel	316L
18	Adjusting screw with bushing	1.4104 PTFE	1.4404 PTFE
		Chrome steel PTFE	316L PTFE
19	Lock nut	1.0718	1.4404
		Steel	316L
22	Lift stopper	1.4404	1.4404
		316L	316L
40	Cap H2	1.0460	1.4404
		SA 105	316L
54	Spring standard	1.1200, 1.8159, 1.7102	1.4310
		Carbon steel	Stainless steel
	Spring optional	1.4310	-
		Stainless steel	-
55	Stud	1.4401	1.4401
		B8M	B8M
56	Nut	1.4401	1.4401
		8M	8M
57	Pin	1.4310	1.4310
		Stainless steel	Stainless steel
60	Gasket	Graphite / 1.4401	Graphite / 1.4401
		Graphite / 316	Graphite / 316
61	Ball	1.3541	1.4401
		Hardened stainless steel	316

**Please notice:**

- Modifications reserved by LESER
- If several materials are specified LESER defines the material.
- LESER can upgrade materials without notice.
- Every part can be replaced by other material acc. to customer specification.

**Type 441, 442 Full nozzle DIN, ANSI**  
**Article numbers**

Type 441, 442 Full nozzle DIN

	DN <sub>i</sub>	25	40	50
	DN <sub>o</sub>	50	65	80
	Actual Orifice diameter d <sub>o</sub> [mm]	23	37	46
	Actual Orifice area A <sub>o</sub> [mm <sup>2</sup> ]	416	1075	1662
<b>Body material: 1.0619 (WCB)</b>				
<b>Bonnet closed</b>	<b>H2</b>	Art. No. <b>4412.</b>	<b>0572</b>	<b>0582</b>
	<b>H3</b>	Art. No. <b>4412.</b>	<b>0573</b>	<b>0583</b>
	<b>H4</b>	Art. No. <b>4412.</b>	<b>0574</b>	<b>0584</b>
<b>open</b>	<b>H3</b>	Art. No. <b>4422.</b>	<b>0575</b>	<b>0585</b>
<b>Body material: 1.4408 (CF8M)</b>				
<b>Bonnet closed</b>	<b>H2</b>	Art. No. <b>4414.</b>	<b>0952</b>	<b>0962</b>
	<b>H4</b>	Art. No. <b>4414.</b>	<b>0954</b>	<b>0964</b>

Type 441, 442 Full nozzle

Type 441, 442 Full nozzle ANSI

	Valve size	1" x 2"	1½" x 2"	1½" x 2½"	2" x 3"	3" x 4"	4" x 6"
	Actual Orifice diameter d <sub>o</sub> [mm]	23	29	37	46	60	92
	Actual Orifice area A <sub>o</sub> [mm <sup>2</sup> ]	416	661	1075	1662	2827	6648
<b>Body material: 1.0619 (WCB)</b>							
<b>Bonnet closed</b>	<b>H2</b>	Art. No. <b>4412.</b>	<b>1282</b>	<b>1292</b>	<b>1302</b>	<b>1312</b>	<b>1322</b>
	<b>H3</b>	Art. No. <b>4412.</b>	<b>1283</b>	<b>1293</b>	<b>1303</b>	<b>1313</b>	<b>1323</b>
	<b>H4</b>	Art. No. <b>4412.</b>	<b>1284</b>	<b>1294</b>	<b>1304</b>	<b>1314</b>	<b>1324</b>
<b>open</b>	<b>H3</b>	Art. No. <b>4422.</b>	<b>1285</b>	<b>1295</b>	<b>1305</b>	<b>1315</b>	<b>1325</b>
<b>Body material: 1.4408 (CF8M)</b>							
<b>Bonnet closed</b>	<b>H2</b>	Art. No. <b>4414.</b>	<b>5682</b>	-	<b>5702</b>	<b>5712</b>	<b>5722</b>
	<b>H4</b>	Art. No. <b>4414.</b>	<b>5684</b>	-	<b>5704</b>	<b>5714</b>	<b>5724</b>

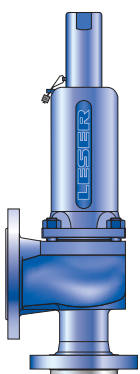

**Type 441 Full nozzle**  
 Cap H2  
 Closed bonnet  
 Conventional design

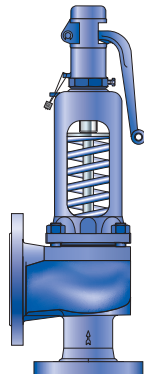

**Type 442 Full nozzle**  
 Plain lever H3  
 Bonnet open  
 Conventional design

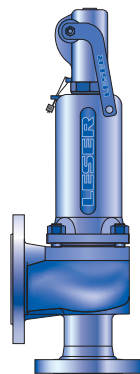

**Type 441 Full nozzle**  
 Packed lever H4  
 Closed bonnet  
 Conventional design

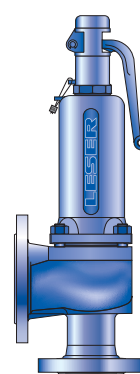

**Type 441 Full nozzle**  
 Plain lever H3  
 Closed bonnet  
 Conventional design

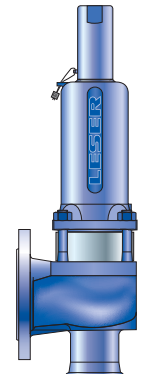

**Type 441 Full nozzle**  
 Cap H2  
 Closed bonnet  
 Balanced bellows design

## Type 441, 442 Full nozzle DIN Dimensions and weights

### Metric Units

	DN <sub>i</sub>	25	40	50
	DN <sub>o</sub>	50	65	80
	Actual Orifice diameter d <sub>0</sub> [mm]	23	37	46
	Actual Orifice area A <sub>0</sub> [mm <sup>2</sup> ]	416	1075	1662
<b>Weight</b>		9	16	22
[kg]	with bellows	10	17	24
<b>Center to face</b>	Inlet a	111	143.5	154
[mm]	Outlet b	100	115	120
<b>Height (H4)</b>	Standard H max.	345	515.5	573
[mm]	Bellows H max.	384	553.5	619
<b>Body material: 1.0619 (WCB)</b>				
<b>DIN Flange<sup>1)</sup></b>	Inlet	PN 40 or 16		
	Outlet	PN 16		
<b>Body material: 1.4408 (CF8M)</b>				
<b>DIN Flange<sup>1)</sup></b>	Inlet	PN 40 or 16		
	Outlet	PN 16		

### US Units

	DN <sub>i</sub>	25	40	50
	DN <sub>o</sub>	50	65	80
	Actual Orifice diameter d <sub>0</sub> [inch]	0.91	1.46	1.81
	Actual Orifice area A <sub>0</sub> [inch <sup>2</sup> ]	0.644	1.667	2.576
<b>Weight</b>		20	35	49
[lbs]	with bellows	21	38	52
<b>Center to face</b>	Inlet a	4 3/8	5 5/8	6 1/16
[inch]	Outlet b	3 15/16	4 1/2	4 3/4
<b>Height (H4)</b>	Standard H max.	9 3/16	13	14 5/8
[inch]	Bellows H max.	10 11/16	14	16 1/8
<b>Body material: 1.0619 (WCB)</b>				
<b>DIN Flange<sup>1)</sup></b>	Inlet	PN 40 or 16		
	Outlet	PN 16		
<b>Body material: 1.4408 (CF8M)</b>				
<b>DIN Flange<sup>1)</sup></b>	Inlet	PN 40 or 16		
	Outlet	PN 16		

<sup>1)</sup> Standard flange rating. For other flange drillings please refer to page 46.

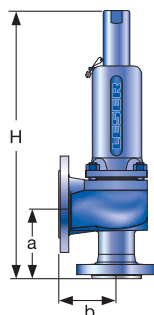

Conventional design

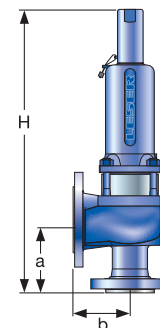

Balanced bellows design

**Type 441, 442 Full nozzle ANSI**

**Dimensions and weights**

Metric Units

Type 441, 442  
Full nozzle

Valve size	1" x 2"	1½" x 2"	1½" x 2½"	2" x 3"	3" x 4"	4" x 6"
Actual Orifice diameter $d_o$ [mm]	23	29	37	46	60	92
Actual Orifice area $A_o$ [mm <sup>2</sup> ]	416	661	1075	1662	2827	6648
<b>Weight</b> [kg]	10	13	16	22	33	75
with bellows	11	14	17	24	37	83
<b>Center to face</b> [mm]						
Inlet a	109	129,5	129,5	141	163	188
Outlet b	114	121	121	124	165	229
<b>Height (H4)</b> [mm]						
Standard H max.	339	455	496	556	685	844
Bellows H max.	378	497	534	602	741	902
<b>Support brackets</b> [mm]						
A						280
B						160
(drilled only on request, Option code H42)						Ø 18
D						250
E						25
<b>Body material: 1.0619 (WCB)</b>						
<b>ANSI Flange<sup>1)</sup></b>	Inlet	CL150 or CL300				
<b>Class</b>	Outlet	CL150				
<b>Body material: 1.4408 (CF8M)</b>						
<b>ANSI Flange<sup>1)</sup></b>	Inlet	CL150 or CL300	-	CL150 or CL300		
<b>Class</b>	Outlet	CL150	-	CL150		

<sup>1)</sup> Standard flange rating. For other flange drillings please refer to page 46.

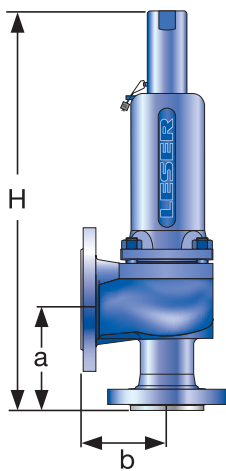

Conventional design

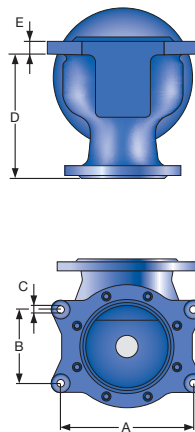

Support brackets

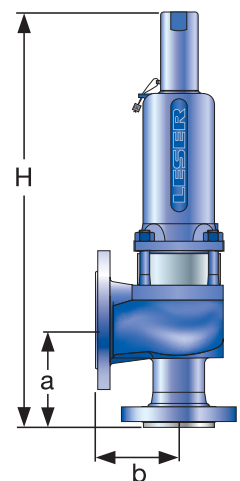

Balanced bellows design



## Type 441, 442 Full nozzle ANSI

### Dimensions and weights

US Units

Valve size	1" x 2"	1½" x 2"	1½" x 2½"	2" x 3"	3" x 4"	4" x 6"
Actual Orifice diameter $d_0$ [inch]	0.91	1.14	1.46	1.81	2.36	3,62
Actual Orifice area $A_0$ [inch <sup>2</sup> ]	0.644	1.024	1.667	2.576	4.383	10,304
<b>Weight</b> [lbs]	22	29	35	49	73	165
with bellows	23	30	38	52	81	183
<b>Center to face</b> [inch]						
Inlet a	4 ¼	5 ⅛	5 ⅛	5 ½	6 ⅜	7 ⅜
Outlet b	4 ½	4 ¾	4 ¾	4 ⅞	6 ½	9
<b>Height (H4)</b> [inch]						
Standard H max.	13 ¼	18 ⅛	19 ¾	22 ⅛	27 ¼	33 ½
Bellows H max.	15 ⅛	19 ⅜	21 ¼	23 ⅞	29 ⅞	35 ⅜
<b>Support brackets</b> [inch]						
A						11
B						6 ¼
(drilled only on request, Option code H42)						Ø ¾
C						9 ⅞
D						1
E						
<b>Body material: 1.0619 (WCB)</b>						
<b>ANSI Flange<sup>1)</sup> Class</b>	Inlet	CL150 or CL300				
	Outlet	CL150				
<b>Body material: 1.4408 (CF8M)</b>						
<b>ANSI Flange<sup>1)</sup> Class</b>	Inlet	CL150 or CL300	–	CL150 or CL300		
	Outlet	CL150	–	CL150		

<sup>1)</sup> Standard flange rating. For other flange drillings please refer to page 46.

Type 441, 442 Full nozzle

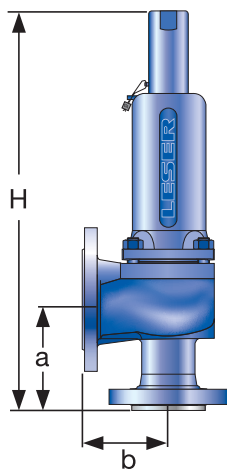

Conventional design

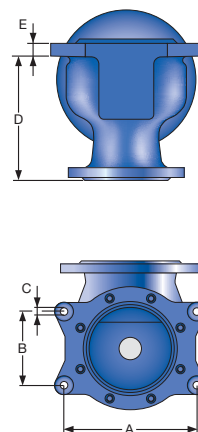

Support brackets

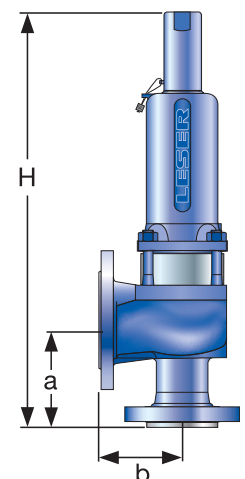

Balanced bellows design

## Type 441, 442 Full nozzle DIN

### Pressure temperature ratings

Metric Units

 Type 441, 442  
Full nozzle

		DN <sub>i</sub>	25	40	50
		DN <sub>o</sub>	50	65	80
		Actual Orifice diameter d <sub>o</sub> [mm]	23	37	46
		Actual Orifice area A <sub>o</sub> [mm <sup>2</sup> ]	416	1075	1662
<b>Body material: 1.0619 (WCB)</b>					
<b>DIN Flange</b>	Inlet	<b>PN 40 or 16</b>			
	Outlet	<b>PN 16</b>			
<b>Minimum set pressure</b>	p [bar <sub>g</sub> ] S/G/L	0.1	0.1	0.1	0.1
<b>Min. set pressure<sup>1)</sup> standard bellows</b>	p [bar <sub>g</sub> ] S/G/L	3	3	3	3
<b>Min. set pressure low press. bellows</b>	p [bar <sub>g</sub> ] S/G/L	0.98	1.11	1.81	1.81
<b>Maximum set pressure</b>	p [bar <sub>g</sub> ] S/G/L	40	40	40	40
<b>Max. set pressure with special spring</b>	p [bar <sub>g</sub> ] S/G/L	40	40	40	40
<b>Temperature<sup>2)</sup> acc. to DIN EN</b>	min. [°C]	-85			
	max. [°C]	+450			
<b>Temperature<sup>2)</sup> acc. to ASME</b>	min. [°C]	-29			
	max. [°C]	+427			

<b>Body material: 1.4408 (CF8M)</b>					
<b>DIN Flange</b>	Inlet	<b>PN 40 or 16</b>			
	Outlet	<b>PN 16</b>			
<b>Minimum set pressure</b>	p [bar <sub>g</sub> ] S/G/L	0.1	0.1	0.1	0.1
<b>Min. set pressure<sup>1)</sup> standard bellows</b>	p [bar <sub>g</sub> ] S/G/L	3	3	3	3
<b>Min. set pressure low press. bellows</b>	p [bar <sub>g</sub> ] S/G/L	0.98	1.11	1.81	1.81
<b>Maximum set pressure</b>	p [bar <sub>g</sub> ] S/G/L	40	40	33	33
<b>Max. set pressure with special spring</b>	p [bar <sub>g</sub> ] S/G/L	40	40	37	37
<b>Temperature<sup>2)</sup> acc. to DIN EN</b>	min. [°C]	-270			
	max. [°C]	+400			
<b>Temperature<sup>2)</sup> acc. to ASME</b>	min. [°C]	-268			
	max. [°C]	+538			

<sup>1)</sup> Min. set pressure standard bellows = Max. set pressure low pressure bellows.

<sup>2)</sup> Between -10 °C and lowest temperature indicated „AD 2000-Merkblatt“ W10 shall be taken into account.

## Type 441, 442 Full nozzle DIN

### Pressure temperature ratings

#### US Units

	DN <sub>E</sub>	25	40	50
	DN <sub>A</sub>	50	65	80
	Actual Orifice diameter d <sub>0</sub> [inch]	0.91	1.46	1.81
	Actual Orifice area A <sub>0</sub> [inch <sup>2</sup> ]	0.644	1.667	2.576
<b>Body material: 1.0619 (WCB)</b>				
<b>DIN Flange</b>	Inlet	<b>PN 40 or 16</b>		
	Outlet	<b>PN 16</b>		
<b>Minimum set pressure</b>	p [psig] S/G/L	1.5	1.5	1.5
<b>Min. set pressure<sup>1)</sup></b> standard bellows	p [psig] S/G/L	43.5	43.5	43.5
<b>Min. set pressure</b> low press. bellows	p [psig] S/G/L	14	16	26
<b>Maximum set pressure</b>	p [psig] S/G/L	580	580	580
<b>Max. set pressure</b> with special spring	p [psig] S/G/L	580	580	580
<b>Temperature<sup>2)</sup></b> acc. to DIN EN	min. [°F]	-121		
	max. [°F]	+842		
<b>Temperature<sup>2)</sup></b> acc. to ASME	min. [°F]	-20		
	max. [°F]	+800		

<b>Body material: 1.4408 (CF8M)</b>				
<b>DIN Flange</b>	Inlet	<b>PN 40 or 16</b>		
	Outlet	<b>PN 16</b>		
<b>Minimum set pressure</b>	p [psig] S/G/L	1.5	1.5	1.5
<b>Min. set pressure<sup>1)</sup></b> standard bellows	p [psig] S/G/L	43.5	43.5	43.5
<b>Min. set pressure</b> low press. bellows	p [psig] S/G/L	14	16	26
<b>Maximum set pressure</b>	p [psig] S/G/L	580	580	479
<b>Max. set pressure</b> with special spring	p [psig] S/G/L	580	580	537
<b>Temperature<sup>2)</sup></b> acc. to DIN EN	min. [°F]	-454		
	max. [°F]	+752		
<b>Temperature<sup>2)</sup></b> acc. to ASME	min. [°F]	-450		
	max. [°F]	+1000		

<sup>1)</sup> Min. set pressure standard bellows = Max. set pressure low pressure bellows.

<sup>2)</sup> Between -10 °C and lowest temperature indicated „AD 2000-Merkblatt“ W10 shall be taken into account.

## Type 441, 442 Full nozzle ANSI

### Pressure temperature ratings

Metric Units

Valve size		1" x 2"	1½" x 2"	1½" x 2½"	2" x 3"	3" x 4"	4" x 6"
Actual Orifice diameter d <sub>0</sub> [mm]		23	29	37	46	60	92
Actual Orifice area A <sub>0</sub> [mm <sup>2</sup> ]		416	661	1075	1662	2827	6648
<b>Body material: 1.0619 (WCB)</b>							
ANSI Flange Class <sup>1)</sup>	Inlet	CL150 or CL300					
	Outlet	CL150					
<b>Minimum set pressure</b>	p [bar <sub>g</sub> ] S/G/L	0.1	0.1	0.1	0.1	0.1	0.1
<b>Min. set pressure<sup>2)</sup> standard bellows</b>	p [bar <sub>g</sub> ] S/G/L	3	3	3	3	3	3
<b>Min. set pressure low press. bellows</b>	p [bar <sub>g</sub> ] S/G/L	0.98	1.41	1.11	1.81	1.50	1.18
<b>Maximum set pressure</b>	p [bar <sub>g</sub> ] S/G/L	49	48	46	40 <sup>3)</sup>	40	34
<b>Max. set pressure with special spring</b>	p [bar <sub>g</sub> ] S/G/L	51	48	46	40 <sup>3)</sup>	40	34
<b>Temperature acc. to DIN EN</b>	min. [°C]	-85					
	max. [°C]	+450					
<b>Temperature acc. to ASME</b>	min. [°C]	-29					
	max. [°C]	+427					

Type 441, 442 Full nozzle

<b>Body material: 1.4408 (CF8M)</b>							
ANSI Flange Class <sup>1)</sup>	Inlet	CL 150 or CL 300	-	CL150 or CL300			
	Outlet	CL150	-	CL150			
<b>Minimum set pressure</b>	p [bar <sub>g</sub> ] S/G/L	0.1	-	0.1	0.1	0.1	0.1
<b>Min. set pressure<sup>2)</sup> standard bellows</b>	p [bar <sub>g</sub> ] S/G/L	3	-	3	3	3	3
<b>Min. set pressure low press. bellows</b>	p [bar <sub>g</sub> ] S/G/L	0.98	-	1.11	1.81	1.50	1.18
<b>Maximum set pressure</b>	p [bar <sub>g</sub> ] S/G/L	42.5	-	27	25	27	15
<b>Max. set pressure with special spring</b>	p [bar <sub>g</sub> ] S/G/L	51	-	38	40	27	25
<b>Temperature acc. to DIN EN</b>	min. [°C]	-270	-	-270			
	max. [°C]	+400	-	+400			
<b>Temperature acc. to ASME</b>	min. [°C]	-268	-	-268			
	max. [°C]	+538	-	+538			

<sup>1)</sup> For flange rating class 150 the pressure temperature ratings according to ASME ANSI B 16.34 apply.

<sup>2)</sup> Min. set pressure standard bellows = Max. set pressure low pressure bellows.

<sup>3)</sup> For applications with CE marking. Maximum set pressure for ASME application 49 bar.

## Type 441, 442 Full nozzle ANSI

### Pressure temperature ratings

US Units

Valve size		1" x 2"	1½" x 2"	1½" x 2½"	2" x 3"	3" x 4"	4" x 6"
Actual Orifice diameter $d_0$ [inch]		0.91	1.14	1.46	1.81	2.36	3.62
Actual Orifice area $A_0$ [inch <sup>2</sup> ]		0.644	1.024	1.667	2.576	4.383	10.304
<b>Body material: 1.0619 (WCB)</b>							
<b>ANSI Flange Class<sup>1)</sup></b>	Inlet	<b>CL150 or CL300</b>					
	Outlet	<b>CL150</b>					
<b>Minimum set pressure</b>	p [psig] S/G/L	1.5	1.5	1.5	1.5	1.5	1.5
<b>Min. set pressure<sup>2)</sup> standard bellows</b>	p [psig] S/G/L	43.5	43.5	43.5	43.5	43.5	43.5
<b>Min. set pressure low press. bellows</b>	p [psig] S/G/L	14	20	16	26	22	17
<b>Maximum set pressure</b>	p [psig] S/G/L	711	696	667	580 <sup>3)</sup>	580	493
<b>Max. set pressure with special spring</b>	p [psig] S/G/L	740	696	667	580 <sup>3)</sup>	580	493
<b>Temperature acc. to DIN EN</b>	min. [°F]	-121					
	max. [°F]	+842					
<b>Temperature acc. to ASME</b>	min. [°F]	-20					
	max. [°F]	+800					

Type 441, 442 Full nozzle

<b>Body material: 1.4408 (CF8M)</b>							
<b>ANSI Flange Class<sup>1)</sup></b>	Inlet	<b>CL 150 or CL 300</b>	-	<b>CL150 or CL300</b>			
	Outlet	<b>CL150</b>	-	<b>CL150</b>			
<b>Minimum set pressure</b>	p [psig] S/G/L	1.5	-	1.5	1.5	1.5	1.5
<b>Min. set pressure<sup>2)</sup> standard bellows</b>	p [psig] S/G/L	43.5	-	43.5	43.5	43.5	43.5
<b>Min. set pressure low press. bellows</b>	p [psig] S/G/L	14	-	16	26	22	17
<b>Maximum set pressure</b>	p [psig] S/G/L	616	-	392	363	392	218
<b>Max. set pressure with special spring</b>	p [psig] S/G/L	740	-	551	580	392	
<b>Temperature acc. to DIN EN</b>	min. [°F]	-454	-	-454			
	max. [°F]	+752	-	+752			
<b>Temperature acc. to ASME</b>	min. [°F]	-450	-	-450			
	max. [°F]	+1000	-	+1000			

<sup>1)</sup> For flange rating class 150 the pressure temperature ratings according to ASME ANSI B16.34 apply.

<sup>2)</sup> Min. set pressure standard bellows = Max. set pressure low pressure bellows.

<sup>3)</sup> For applications with CE marking. Maximum set pressure for ASME application 711 psig.

## Type 441, 442 Full nozzle DIN, ANSI Flange drillings

### Type 441, 442 Full nozzle DIN

	DN <sub>i</sub>	25	40	50	
	DN <sub>o</sub>	50	65	80	
	Actual Orifice diameter d <sub>0</sub> [mm]	23	37	46	
	Actual Orifice area A <sub>0</sub> [mm <sup>2</sup> ]	416	1075	1662	
<b>Body material: 1.0619 (WCB), 1.4408 (CF8M)</b>					
<b>Inlet</b>	<b>DIN EN 1092</b>	PN 10	*	*	*
		PN 16	*	*	*
		PN 25	*	*	*
		PN 40	*	*	*
	<b>ASME B16.5</b>	CL150	H64	H64	H64
		CL300	–	–	[H65]
<b>Outlet</b>	<b>DIN EN 1092</b>	PN 10	*	*	*
		PN 16	*	*	*
		PN 25	*	(H15)	(*)
		PN 40	*	(H15)	(*)
	<b>ASME B16.5</b>	CL150	H 79	H 79	H 79
		CL300	–	–	–

### Type 441, 442 Full nozzle ANSI

Valve size	1" x 2"	1½" x 2"	1½" x 2½"	2" x 3"	3" x 4"	4" x 6"	
Actual Orifice diameter d <sub>0</sub> [mm]	23	29	37	46	60	92	
Actual Orifice area A <sub>0</sub> [mm <sup>2</sup> ]	416	661	1075	1662	2827	6648	
<b>Body material: 1.0619 (WCB), 1.4408 (CF8M)</b>							
<b>Inlet</b>	<b>DIN EN 1092</b>	PN 25	Please use 441, 442 Full nozzle DIN			H47	H47
		PN 40	Please use 441, 442 Full nozzle DIN			H47	H47
	<b>ASME B16.5</b>	CL150	H64	H64	H64	H64	[H64]
		CL300	*	*	*	*	*
<b>Outlet</b>	<b>DIN EN 1092</b>	PN 10	Please use 441, 442 Full nozzle DIN			H51	H51
		PN 16	Please use 441, 442 Full nozzle DIN			H51	H51
	<b>ASME B16.5</b>	CL150	*	*	*	*	*
		CL300	–	–	–	–	–

## Type 441, 442 Full nozzle DIN, ANSI Flange facings

Indication	Standard	Inlet	Outlet	Remark						
<b>General</b>										
Flange undrilled	–	H38	H39							
Linde-V-Nut, Type V48	Linde Standard 420-08 LDeS 3313.36	–	J08	Groove: Rz 16						
Linde-V-Nut, Type V48A		–	J06	Groove: Rz 4, e.g. with hydrogen						
Lens seal form L (without sealing lens)	DIN 2696 LDeS 3313.35	–	J12							
<b>Acc. to DIN EN 1092</b>										
<b>Flange facing</b> (see LDeS 3313.40)		PN 10 – PN 40	PN 10 – PN 40	Rz-data according to DIN EN 1092 in µm						
Raised face	Type B1	*	*	Facing: Rz = 12.5 – 50						
	Type B2	-	L38	Facing: Rz = 3.2 – 12.5						
Tongue face C <sup>1)</sup>		L56	H92	Steel flange only						
Groove face D <sup>1)</sup>		L55	H91							
Male face E		H96	H98							
Female face F		H97	H99							
O-ring male face G		J01	J02							
O-ring female face H		J03	J04							
<b>Acc. to ASME B16.5</b>										
Body material	Inlet	Outlet	Smooth finish <sup>2)</sup>		Serrated finish		RTJ-groove			
			Inlet	Outlet	Inlet	Outlet	Inlet		Outlet	
			Option code	Option code	Option code	Option code	RTJ- Class	Option code	RTJ- Class	Option code
1.0619, 1.4408	all	all	L52	L53	*	*	CL150, CL300	L58	CL150	H63

<sup>1)</sup> LESER manufactures the groove at flanged valves by milling. If a customer demands a turned surface in the soil of the groove according to DIN EN 1092-1 an additional option code is necessary: "S01: soil of the groove drilled".

<sup>2)</sup> Smooth finish is not defined in the effective standards.

Note: Flange drillings and facings meet always the requirements of mentioned flange standards.  
Flange thickness and outer diameter may vary from flange standard.

## Series 441, Series 441 Full nozzle

### Approvals

DN <sub>i</sub>	20	25	32	40	50	65	80	100	125	150	200
Valve size	–	1" x 2"	1½" x 2"	1½" x 2½"	2" x 3"	3" x 4"	–	4" x 6"	–	–	–
Actual Orifice diameter d <sub>0</sub> [mm]		23	29	37	46	60	74	92	98	125	165
Actual Orifice area A <sub>0</sub> [mm <sup>2</sup> ]	254	416	661	1075	1662	2827	4301	6648	7543	12272	21382
<b>Europe</b>			<b>Coefficient of discharge K<sub>dr</sub></b>								
PED / DIN EN ISO 4126-1 12/2013	Approval No.	072020111Z0008/0/08 Rev.3									
	S/G	0.7									
	L	0.45									
<b>Germany</b>			<b>Coefficient of discharge α<sub>w</sub></b>								
PED / AD 2000-Merkblatt A2 07/2012	Approval No.	TÜV SV 576									
	S/G	0.7									
	L	0.45									
<b>United States</b>			<b>Coefficient of discharge K</b>								
ASME Sec. VIII Div. 1	Approval No.	M37044									
	S/G	0.699									
	Approval No.	M37055									
	L	0.521									
<b>Canada</b>			<b>Coefficient of discharge K</b>								
CRN	Approval No.	For current approval no. see www.leser.com									
	S/G	0.699									
	L	0.521									
<b>China</b>			<b>Coefficient of discharge α<sub>w</sub></b>								
AQSIQ	Approval No.	For current approval no. see www.leser.com									
	S/G	0.7									
	L	0.45									
<b>Eurasian Custom Union</b>			<b>Coefficient of discharge α<sub>w</sub></b>								
EAC	Approval No.	For current approval no. see www.leser.com									
	S/G	0.7									
	L	0.45									
<b>Classification societies</b>		<b>Homepage</b>									
Bureau Veritas	BV	www.bureauveritas.com									The valid certification number is changed with every renewal.  For a sample certificate including the valid certification number see www.leser.com
DNV GL		www.dnvgl.com									
Lloyd' s Register EMEA	LREMEA	www.lr.org									
Registro Italiano Navale	RINA	www.rina.org									
U.S. Coast Guard	U.S.C.G.	www.uscg.org									
ClassNK NIPPON Kaiji Kyokai (Japan)		www.classnk.or.jp									



## Series 441, Series 441 Full nozzle Available options

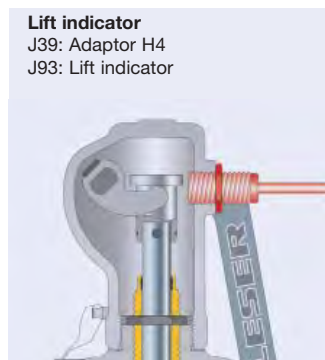
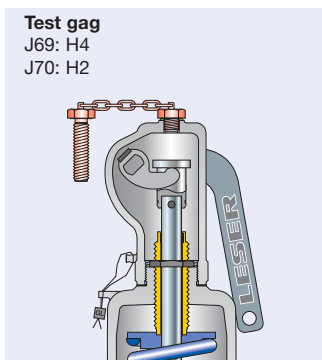
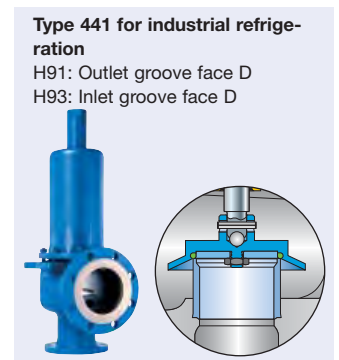
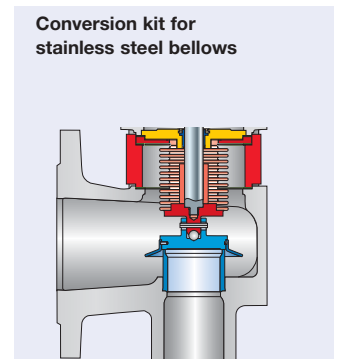
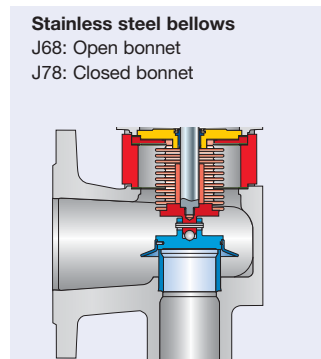
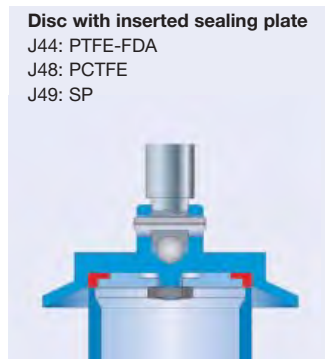
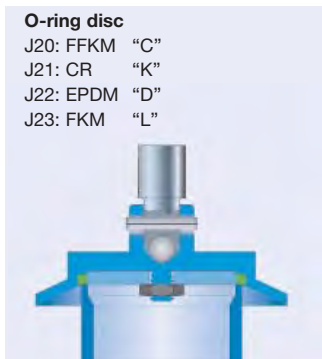
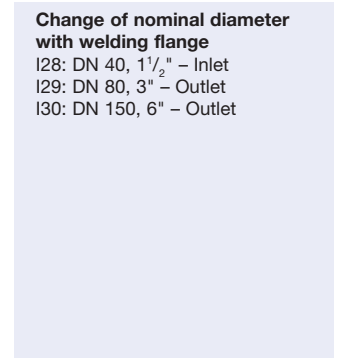
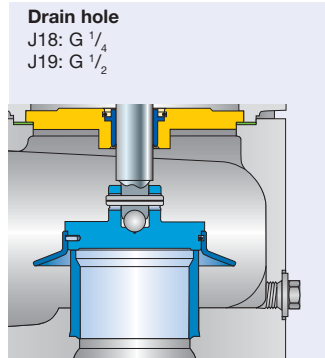
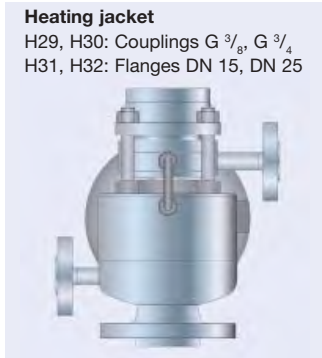

Series 441,  
441 Full nozzle

**Serie 441, Serie 441 Full nozzle**  
**LESER Original Spare Parts Kits**

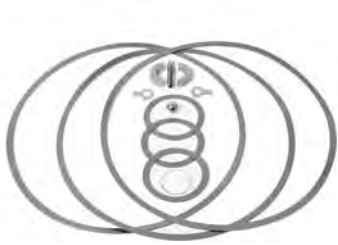

The LESER Spare Parts Kits contain all the parts recommended for the regular maintenance of a LESER safety valve

**Contents**

Item	Component	Material	Quantity
7.5	Securing ring (Disc)	1.4571 / 316Ti	1
8.4	Securing ring (Guide)	1.4571 / 316Ti	1
14	Split ring	1.4404 / 316L	2
40.3	Spacer	1.4571 / 316Ti	3
57	Pin	1.4310 / Stainless steel	1
59	Securing ring (Split ring)	1.4571 / 316Ti	1
60	Gasket	Graphite / 1.4401 Graphite / 316	3
61	Ball	1.4401 / 316	1
1.9	O-ring (Lifting device H4)	FKM	1

**Article numbers**

DN	20	25	32	40	50	65	80	100	125	150	200
Valve size	-	1" x 2"	1½" x 2"	1½" x 2½"	2" x 3"	3" x 4"	-	4" x 6"	-	-	-
Art. No. 5012.	1201	1202	1203	1204	1205	1206	1207	1208	1209	1210	1211

For further spare parts of your individually configured safety valve, please use the spare part finder [www.leser.com/en/services/spare-part-finder.html](http://www.leser.com/en/services/spare-part-finder.html)

Series 441,  
441 Full nozzle



**Type 441 XXL**  
 Packed lever H4  
 Closed bonnet  
 Conventional and  
 balanced bellows design

**Type 441, 442 XXL**  
**Flanged Safety Relief Valves**

<b>Contents</b>	<b>Page</b>
<b>Materials</b>	
• Conventional design	52
• Balanced bellows design	54
<b>Article numbers</b>	56
<b>Dimensions and weights</b>	
• Metric Units	57
• US Units	58
<b>Pressure temperature ratings</b>	
• Metric Units	59
• US Units	60
Flange drillings and facings	61
Approvals	62
Available options	63

Type 441, 442  
XXL

**Type 441, 442 XXL**  
**Conventional design**

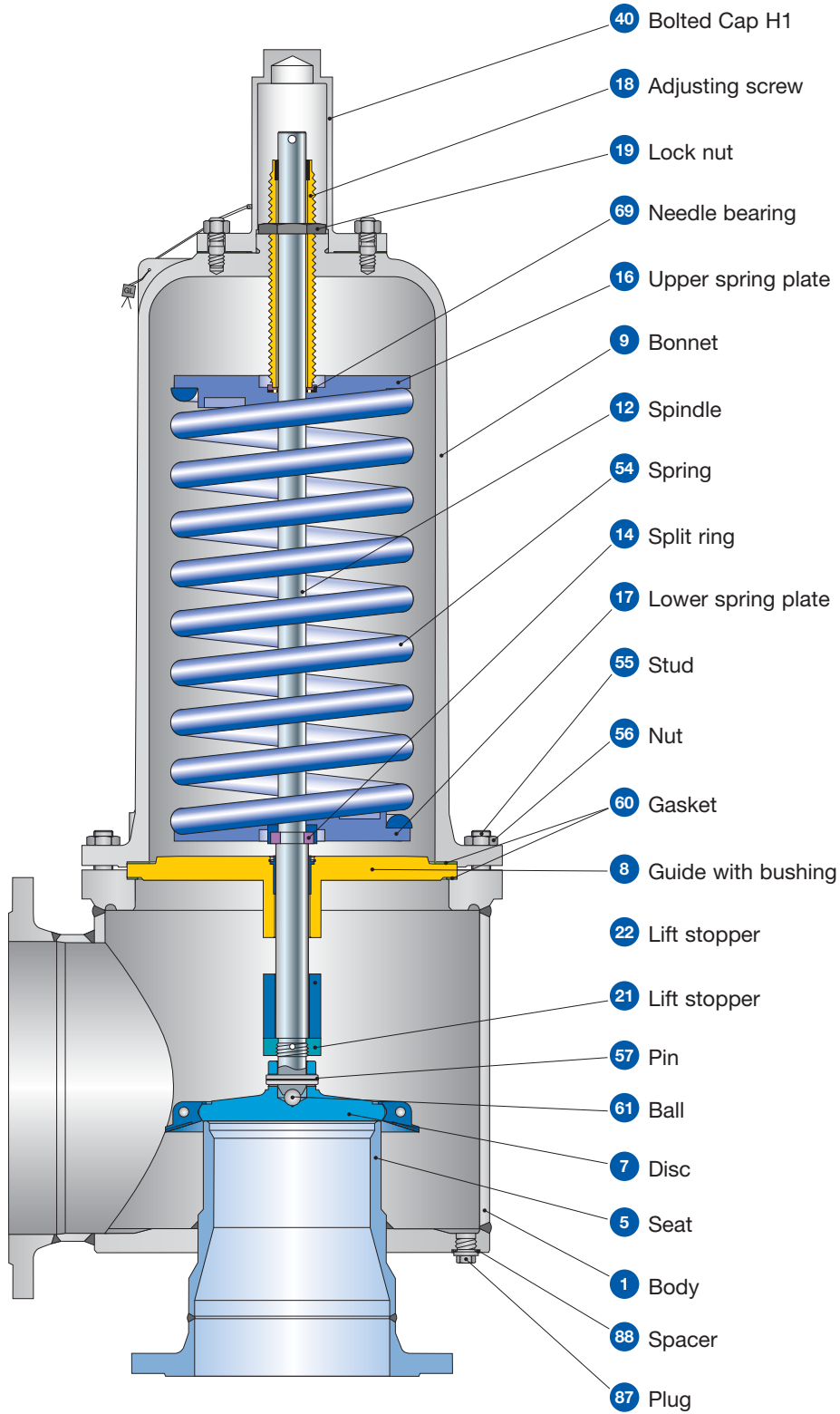

Type 441, 442  
 XXL

## Type 441, 442 XXL

### Conventional design

### Materials

**Please notice:**

- Modifications reserved by LESER. If several materials are specified LESER defines the material.
- LESER can upgrade materials without notice.
- Every part can be replaced by other material acc. to customer specification.
- <sup>1)</sup> Bolted cap H1 only available for DN 200 and DN 250.

Item	Component	Type 4412 XXL / 4422 XXL		Type 4414 XXL	
1	Body	Inlet: 1.4571	Outlet: 1.0460 / 1.0425	1.4571	
		Inlet: 316Ti	Outlet: Carbon steel	316Ti	
5	Seat	1.0305 stellite, 1.0460 stellite		1.4571	
		Carbon steel, stellite		316Ti	
7	Disc	1.4404		1.4404	
		316L		316L	
8	DN 200 – 250: Guide with bushing	0.7040		1.4404	
		Ductile Gr. 60-40-18 / Chrome steel		316L	
	DN 300 – 400: Guide	1.4404		1.4404	
		316L		316L	
9	Bonnet casted	0.7043		-	
		Ductile Gr. 60-40-18		-	
	Bonnet welded	DN 200 / DN 250: 1.4404(316L) / 1.4571(316Ti) / 1.0305 (Steel)		1.4571 / 1.4404	
DN 300 / DN 400: 1.0254 / 1.4571(316Ti) / 1.0345 (Steel) The welded construction may consist of additional materials		316Ti / 316L			
12	Spindle	1.4021		1.4404	
		420		316L	
14	Split ring	1.4104		1.4404	
		Chrome steel		316L	
16 / 17	Spring plate	1.0570 or 1.4404		1.4404	
		Steel or 316L		316L	
18	Adjusting screw with bushing	1.4104 PTFE		1.4404 PTFE	
		Chrome steel PTFE		316L PTFE	
19	Lock nut	1.4404		1.4404	
		316L		316L	
21 / 22	Lift stopper	1.4404		1.4404	
		316L		316L	
40	Bolted cap H1 <sup>1)</sup>	DN 200 + DN 250: 0.7040, Flange 1.0460	DN 300 + DN 400: 1.4408	DN 200 + DN 250: 1.4404	DN 300 + DN 400: 1.4408
		Ductil Gr. 60-40-18, Flange SA 105	CF8M	316L	CF8M
54	Spring standard	1.1200, 1.8159, 1.7102		1.4310	
		Carbon steel		Stainless steel	
54	Spring optional	1.4310		-	
		Stainless steel		-	
55	Stud	1.4401		1.4401	
		B8M		B8M	
56	Nut	1.4401		1.4401	
		8M		8M	
57	Pin	1.4310		1.4310	
		Stainless steel		Stainless steel	
60	Gasket	Graphit e/ 1.4401		Graphite / 1.4401	
		Graphite / 316		Graphite / 316	
61	Ball	1.3541		1.4401	
		Hardened stainless steel		316	
69	Needle bearing	1.4401		1.4401	
		316		316	
87 / 88	Plug / Spacer	1.4401 / 1.4571		1.4401 / 1.4571	
		316 / 316Ti		316 / 316Ti	

**Type 441, 442 XXL**  
**Balanced bellows design**

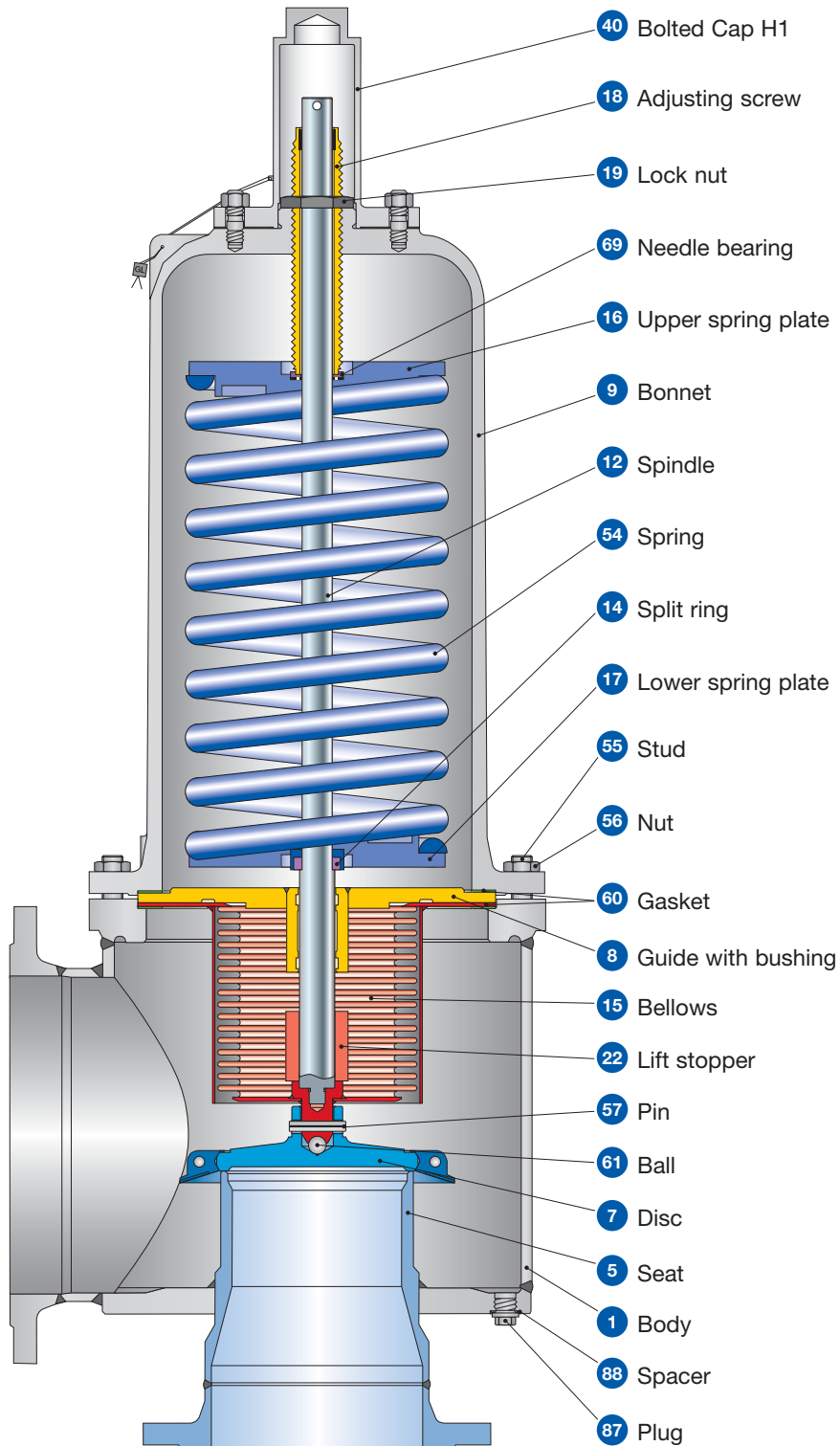

Type 441, 442  
 XXL

# Type 441, 442 XXL

## Balanced bellows design

### Materials

**Please notice:**

- Modifications reserved by LESER. If several materials are specified LESER defines the material.
- LESER can upgrade materials without notice.
- Every part can be replaced by other material acc. to customer specification.
- <sup>1)</sup> Bolted cap H1 only available for DN 200 and DN 250.

Item	Component	Type 4412 XXL / 4422 XXL		Type 4414 XXL	
1	Body	Inlet: 1.4571	Outlet: 1.0460 / 1.0425	1.4571	
		Inlet: 316Ti	Outlet: Carbon steel	316Ti	
5	Seat DN 200 – 250	1.0305 stellite		1.4571	
		Carbon steel, stellite		316Ti	
	DN 300 – 400	1.0460 stellite		1.4571	
		Carbon steel, stellite		316Ti	
7	Disc	1.4404		1.4404	
		316L		316L	
8	Guide	1.4571		1.4571	
		316Ti		316Ti	
9	Bonnet casted	0.7043		-	
		Ductile Gr. 60-40-18		-	
	Bonnet welded	DN 200 / DN 250: 1.4404(316L) / 1.4571(316Ti) / 1.0305 (Steel)		1.4571 / 1.4404	
		DN 300 / DN 400: 1.0254 / 1.4571(316Ti) / 1.0345 (Steel) The welded construction may consist of additional materials		316Ti / 316L	
12	Spindle	1.4404		1.4404	
		316L		316L	
14	Split ring	1.4104		1.4404	
		Chrome steel		316L	
15	Bellows	1.4571		1.4571	
		316Ti		316Ti	
16 / 17	Spring plate	1.0570 or 1.4404		1.4404	
		Steel or 316L		316L	
18	Adjusting screw with bushing	1.4104 PTFE		1.4404 PTFE	
		Chrome steel PTFE		316L PTFE	
19	Lock nut	1.4404		1.4404	
		316L		316L	
22	Lift stopper	1.4404		1.4404	
		316L		316L	
40	Bolted cap H1 <sup>1)</sup>	DN 200 + DN 250: 0.7040, Flange 1.0460	DN 300 + DN 400: 1.4408	DN 200 + DN 250: 1.4404	DN 300 + DN 400: 1.4408
		Ductil Gr. 60-40-18, Flange SA 105	CF8M	316L	CF8M
54	Spring standard	1.1200, 1.8159, 1.7102		1.4310	
		Carbon steel		Stainless steel	
	Spring optional	1.4310		-	
55	Stud	1.4401		1.4401	
		B8M		B8M	
56	Nut	1.4401		1.4401	
		8M		8M	
57	Pin	1.4310		1.4310	
		Stainless steel		Stainless steel	
60	Gasket	Graphite / 1.4401		Graphite / 1.4401	
		Graphite / 316		Graphite / 316	
61	Ball	1.3541		1.4401	
		Hardened stainless steel		316	
69	Needle bearing	1.4401		1.4401	
		316		316	
87 / 88	Plug / Spacer	1.4401 / 1.4571		1.4401 / 1.4571	
		316 / 316Ti		316 / 316Ti	

## Type 441, 442 XXL

### Article numbers

	DN <sub>I+O</sub>	200 x 300	250 x 350	300 x 400	400 x 500	
Valve size		8" x 12"	10" x 14"	12" x 16"	16" x 20"	
Actual Orifice diameter d <sub>0</sub> [mm]		165	200	235	295	
Actual Orifice area A <sub>0</sub> [mm <sup>2</sup> ]		21382	31416	43374	68349	
<b>Body material: 1.0460 / 1.0425 (Carbon steel)</b>						
<b>Bonnet</b>	<b>H1<sup>1)</sup></b>	Art. No. <b>4412.</b>	<b>4752</b>	<b>4762</b>	<b>4772</b>	<b>4782</b>
closed	<b>H3</b>	Art. No. <b>4412.</b>	-	-	-	-
	<b>H6<sup>1)</sup></b>	Art. No. <b>4412.</b>	<b>4754</b>	<b>4764</b>	<b>4774</b>	<b>4784</b>
open	<b>H6<sup>1)</sup></b>	Art. No. <b>4422.</b>	<b>4755</b>	<b>4765</b>	<b>4775</b>	<b>4785</b>
<b>Body material: 1.4571 (316Ti)</b>						
<b>Bonnet</b>	<b>H1<sup>1)</sup></b>	Art. No. <b>4414.</b>	<b>4792</b>	<b>4802</b>	<b>4902</b>	<b>4912</b>
closed	<b>H6<sup>1)</sup></b>	Art. No. <b>4414.</b>	<b>4794</b>	<b>4804</b>	<b>4904</b>	<b>4914</b>

<sup>1)</sup> Bolted cap H1 and bolted lifting device H6 only available for DN 200 and DN 250.  
DN 300 and DN 400 available with cap H2 and lifting device H4.

Type 441, 442  
XXL

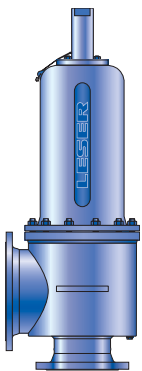

**Type 441 XXL**  
Bolted cap H1  
Closed bonnet  
Conventional and  
balanced bellows design

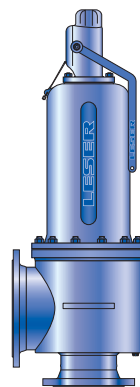

**Type 441 XXL**  
Bolted lifting device H6  
Closed bonnet  
Conventional and  
balanced bellows design

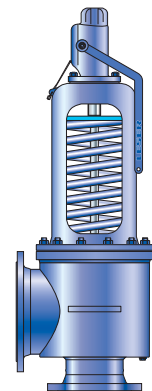

**Type 441 XXL**  
Bolted lifting device H6  
Open bonnet  
Conventional and  
balanced bellows design



## Type 441, 442 XXL

### Dimensions and weights

Metric Units

	DN <sub>I+O</sub>	200 x 300	250 x 350	300 x 400	400 x 500
	Valve size	8" x 12"	10" x 14"	12" x 16"	16" x 20"
	Actual Orifice diameter d <sub>0</sub> [mm]	165	200	235	295
	Actual Orifice area A <sub>0</sub> [mm <sup>2</sup> ]	21382	31416	43374	68349
<b>Weight</b> [kg]		285	335	384	588
	with bellows	289	340	390	595
<b>Center to face</b> [mm]	Inlet a	305	330	330	400
	Outlet b	300	407	394 <sup>1)</sup>	477 <sup>1)</sup>
<b>Height (H6)</b> [mm]	Standard H max.	1473	1518	1633	1953
	Bellows H max.	1473	1518	1633	1953
<b>Support brackets</b> [mm]	A	470	514	640	800
	B	150	150	180	220
(drilled only on request, Option code H42)	C	Ø 18	Ø 18	Ø 24	Ø 28
	D	305	340	330	400
	E	20	20	20	20

#### Body material: 1.0460 / 1.0425 (Carbon steel)

DIN Flange <sup>2)</sup>	Inlet	PN 25	PN 16
	Outlet	PN 10	PN 16

#### Body material: 1.4571 (316Ti)

DIN Flange <sup>2)</sup>	Inlet	PN 25	PN 16
	Outlet	PN 10	PN 16

- <sup>1)</sup> For pressure rating outlet higher than PN 10 centre to face dimension will change  
<sup>2)</sup> Standard flange rating. For other flange drillings and facings please refer to page 61.

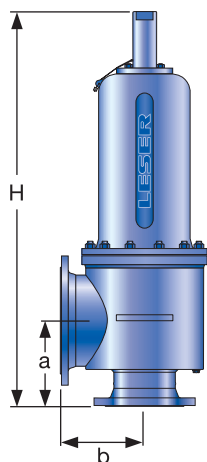

Conventional and balanced bellows design

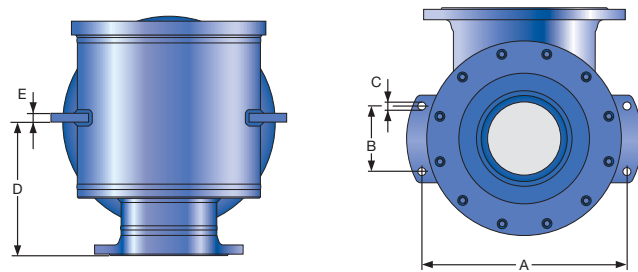

Support brackets

## Type 441, 442 XXL

### Dimensions and weights

US Units

	DN <sub>I+O</sub>	200 x 300	250 x 350	300 x 400	400 x 500
Valve size		8" x 12"	10" x 14"	12" x 16"	16" x 20"
Actual Orifice diameter d <sub>0</sub> [inch]		6.5	7.87	9.25	11.61
Actual Orifice area A <sub>0</sub> [inch <sup>2</sup> ]		33.143	48.695	67.229	105.942
<b>Weight</b> [lbs]		628	739	847	1297
	with bellows	637	750	860	1312
<b>Center to face</b> [inch]	Inlet a	12	13 <sup>3</sup> / <sub>8</sub>	13 (CL300: 13 <sup>3</sup> / <sub>4</sub> )	15 <sup>3</sup> / <sub>4</sub> (CL300: 16 <sup>5</sup> / <sub>32</sub> )
	Outlet b	11 <sup>13</sup> / <sub>16</sub>	12 <sup>13</sup> / <sub>16</sub>	15 <sup>1</sup> / <sub>2</sub>	18 <sup>25</sup> / <sub>32</sub>
<b>Height (H6)</b> [inch]	Standard H max.	58	59 <sup>3</sup> / <sub>4</sub>	64 <sup>5</sup> / <sub>16</sub>	76 <sup>7</sup> / <sub>8</sub>
	Bellows H max.	58	59 <sup>3</sup> / <sub>4</sub>	64 <sup>5</sup> / <sub>16</sub>	76 <sup>7</sup> / <sub>8</sub>
<b>Support brackets</b> [inch]	A	18 <sup>1</sup> / <sub>2</sub>	20 <sup>1</sup> / <sub>4</sub>	25 <sup>3</sup> / <sub>16</sub>	31 <sup>1</sup> / <sub>2</sub>
	B	5 <sup>29</sup> / <sub>32</sub>	5 <sup>29</sup> / <sub>32</sub>	7 <sup>3</sup> / <sub>32</sub>	8 <sup>21</sup> / <sub>32</sub>
(drilled only on request, Option code H42)	C	Ø <sup>29</sup> / <sub>32</sub>	Ø <sup>23</sup> / <sub>32</sub>	Ø <sup>15</sup> / <sub>16</sub>	Ø <sup>3</sup> / <sub>32</sub>
	D	12	13 <sup>3</sup> / <sub>8</sub>	13	15 <sup>3</sup> / <sub>4</sub>
	E	<sup>25</sup> / <sub>32</sub>	<sup>25</sup> / <sub>32</sub>	<sup>25</sup> / <sub>32</sub>	<sup>25</sup> / <sub>32</sub>

#### Body material: 1.0460 / 1.0425 (Carbon steel)

<b>ANSI Flange Class<sup>1)</sup></b>	Inlet	CL150 or CL300
	Outlet	CL150 or CL300

#### Body material: 1.4571 (316Ti)

<b>ANSI Flange Class<sup>1)</sup></b>	Inlet	CL150 or CL300
	Outlet	CL150 or CL300

<sup>1)</sup> Standard flange rating. For other flange drillings and facings please refer to page 61.

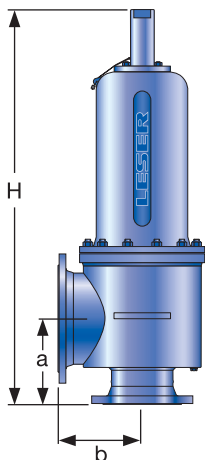

Conventional and balanced bellows design

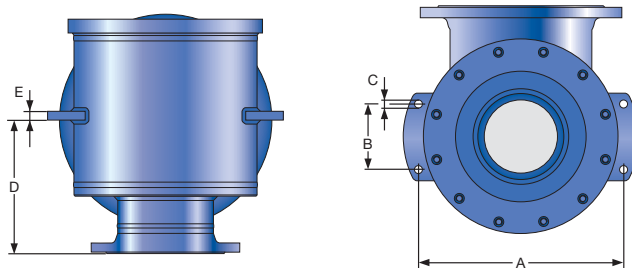

Support brackets

## Type 441, 442 XXL

### Pressure temperature ratings

Metric Units

	DN <sub>I+O</sub>	200 x 300	250 x 350	300 x 400	400 x 500
	Valve size	8" x 12"	10" x 14"	12" x 16"	16" x 20"
	Actual Orifice diameter d <sub>0</sub> [mm]	165	200	235	295
	Actual Orifice area A <sub>0</sub> [mm <sup>2</sup> ]	21382	31416	43374	68349
<b>Body material: 1.0460 / 1.0425 (Carbon steel)</b>					
DIN Flange	Inlet	PN 25		PN 16	
	Outlet	PN 10			
<b>Minimum set pressure</b>	p [bar <sub>g</sub> ] S/G/L	0.2	0.2	0.2	0.2
<b>Min. set pressure<sup>1)</sup> standard bellows</b>	p [bar <sub>g</sub> ] S/G/L	0.2	0.2	0.2	0.2
<b>Min. set pressure low press. bellows</b>	p [bar <sub>g</sub> ] S/G/L	-	-	-	-
<b>Maximum set pressure</b>	p [bar <sub>g</sub> ] S/G/L	20	13.4	9.25	1.25
<b>Max. set pressure with special spring</b>	p [bar <sub>g</sub> ] S/G/L	25	16	16	8
<b>Temperature acc. to DIN EN</b>	min. [°C]	-85			
	max. [°C]	+420			
<b>Temperature acc. to ASME</b>	min. [°C]	-29			
	max. [°C]	+427			

<b>Body material: 1.4571 (316Ti)</b>					
DIN Flange	Inlet	PN 25		PN 16	
	Outlet	PN 10			
<b>Minimum set pressure</b>	p [bar <sub>g</sub> ] S/G/L	0.2	0.2	0.2	0.2
<b>Min. set pressure<sup>1)</sup> standard bellows</b>	p [bar <sub>g</sub> ] S/G/L	0.2	0.2	0.2	0.2
<b>Min. set pressure low press. bellows</b>	p [bar <sub>g</sub> ] S/G/L	-	-	-	-
<b>Maximum set pressure</b>	p [bar <sub>g</sub> ] S/G/L	1.45	0	0	0
<b>Max. set pressure with special spring</b>	p [bar <sub>g</sub> ] S/G/L	10	6	3.57	2.3
<b>Temperature acc. to DIN EN</b>	min. [°C]	-196			
	max. [°C]	+550			
<b>Temperature acc. to ASME</b>	min. [°C]	-184			
	max. [°C]	+427			

<sup>1)</sup> Min. set pressure standard bellows = Max. set pressure low pressure bellows.

## Type 441, 442 XXL

### Pressure temperature ratings

US Units

	DN <sub>I+O</sub>	200 x 300	250 x 350	300 x 400	400 x 500
Valve size		8" x 12"	10" x 14"	12" x 16"	16" x 20"
Actual Orifice diameter d <sub>0</sub> [inch]		6.5	7.87	9.25	11.61
Actual Orifice area A <sub>0</sub> [inch <sup>2</sup> ]		33.143	48.695	67.229	105.942

#### Body material: 1.0460 / 1.0425 (Carbon steel)

ANSI Flange Class <sup>1)</sup>	Inlet		CL150 oder CL300			
	Outlet		CL150			
<b>Minimum set pressure</b>	p [psig]	S/G/L	2.9	2.9	2.9	2.9
<b>Min. set pressure<sup>2)</sup> standard bellows</b>	p [psig]	S/G/L	2.9	2.9	2.9	2.9
<b>Min. set pressure low press. bellows</b>	p [psig]	S/G/L	-	-	-	-
<b>Maximum set pressure</b>	p [psig]	S/G/L	290	194	134	18
<b>Max. set pressure with special spring</b>	p [psig]	S/G/L	363	232	232	116
<b>Temperature acc. to DIN EN</b>	min. [°F]		-121			
	max. [°F]		+788			
<b>Temperature acc. to ASME</b>	min. [°F]		-300			
	max. [°F]		+800			

#### Body material: 1.4571 (316Ti)

ANSI Flange Class <sup>1)</sup>	Inlet		CL150 oder CL300			
	Outlet		CL150			
<b>Minimum set pressure</b>	p [psig]	S/G/L	2.9	2.9	2.9	2.9
<b>Min. set pressure<sup>2)</sup> standard bellows</b>	p [psig]	S/G/L	2.9	2.9	2.9	2.9
<b>Min. set pressure low press. bellows</b>	p [psig]	S/G/L	-	-	-	-
<b>Maximum set pressure</b>	p [psig]	S/G/L	21	0	0	0
<b>Max. set pressure with special spring</b>	p [psig]	S/G/L	145	87	52	33
<b>Temperature acc. to DIN EN</b>	min. [°F]		-321			
	max. [°F]		+1022			
<b>Temperature acc. to ASME</b>	min. [°F]		-300			
	max. [°F]		+800			

<sup>1)</sup> For flange rating class 150 the pressure temperature ratings according to ASME ANSI B 16.34 apply.

<sup>2)</sup> Min. set pressure standard bellows = Max. set pressure low pressure bellows.

## Type 441, 442 XXL

### Flange drillings

	DN <sub>I+O</sub>	200 x 300	250 x 350	300 x 400	400 x 500	
Valve size		8" x 12"	10" x 14"	12" x 16"	16" x 20"	
Actual Orifice diameter d <sub>0</sub> [mm]		165	200	235	295	
Actual Orifice area A <sub>0</sub> [mm <sup>2</sup> ]		21382	31416	43374	68349	
<b>Body material: 1.0460 / 1.0425 (Carbon steel), 1.4571 (316Ti)</b>						
Inlet	DIN EN 1092	PN 10	H44	H44	H44	H44
		PN 16	H45	H45	*	*
		PN 25	*	*	H46	H46
		PN 40	–	–	–	–
	ASME B16.5	CL150	H64	H64	H64	H64
		CL300	H65	–	–	–
Outlet	DIN EN 1092	PN 10	*	*	*	*
		PN 16	H51	H51	H51	H51
		PN 25	–	–	–	–
		PN 40	–	–	–	–
	ASME B16.5	CL150	H79	H79	H79	H79
		CL300	–	–	–	–

### Flange facings

Indication	Standard	Inlet	Outlet	Remark						
<b>General</b>										
Flange undrilled	–	H38	H39							
Linde-V-Nut, Form V48	Linde Standard 420-08	J07	J08	Groove: Rz 16						
Linde-V-Nut, Form V48A	LDeS 3313.36	J05	J06	Groove: Rz 4, e.g. with hydrogen						
Lens seal form L (without sealing lens)	DIN 2696 LDeS 3313.35	J11	J12							
<b>Acc. to DIN EN 1092</b>										
<b>Flange facing</b> (see also LDeS 3313.40)		PN 10 – PN 40	PN 10 – PN 40	Rz-data according to DIN EN 1092 in µm						
Raised face	Type B1	*	*	Facing: Rz = 12.5 – 50						
	Type B2	L36	L38	Facing: Rz = 3.2 – 12.5						
Tongue face C <sup>1)</sup>		H94	H92	Steel flanges only						
Groove face D <sup>1)</sup>		H93	H91							
Male face E		H96	H98							
Female face F		H97	H99							
O-ring male face G		J01	J02							
O-ring female face H		J03	J04							
<b>Acc. to ASME B16.5</b>										
Body material	Inlet	Outlet	Smooth finish <sup>2)</sup>		Serrated finish		RTJ-Groove			
			Inlet	Outlet	Inlet	Outlet	Inlet		Outlet	
			Option code		Option code		RTJ-Class	Option code	RTJ-Class	Option code
1.0619, 1.4408	all	all	L52	L53	*	*	CL150	H62	CL150	H63

<sup>1)</sup> LESER manufactures the groove at flanged valves by milling. If a customer demands a turned surface in the soil of the groove according to DIN EN 1092-1 an additional option code is necessary: "S01: soil of the groove drilled".

<sup>2)</sup> Smooth finish is not defined in the effective standards.

Note: Flange drillings and facings meet always the requirements of mentioned flange standards.  
Flange thickness and outer diameter may vary from flange standard.

## Type 441, 442 XXL

### Approvals

	DN <sub>I+O</sub>	200 x 300	250 x 350	300 x 400	400 x 500
	Valve size	8" x 12"	10" x 14"	12" x 16"	16" x 20"
	Actual Orifice diameter d <sub>0</sub> [mm]	1665	200	235	295
	Actual Orifice area A <sub>0</sub> [mm <sup>2</sup> ]	21382	31416	43374	68349
<b>Europe</b>		<b>Coefficient of discharge K<sub>dr</sub></b>			
PED / DIN EN ISO 4126-1 12/2013	Approval No.	072020111Z0008/0/08 Rev.3			
	S/G	0.75	0.7	0.7	0.7
	L	0.56	0.52	0.52	0.52
<b>Germany</b>		<b>Coefficient of discharge α<sub>w</sub></b>			
PED / AD 2000-Merkblatt A2 07/2012	Approval No.	TÜV SV 576			
	S/G	0.75	0.7	0.7	0.7
	L	0.56	0.52	0.52	0.52
<b>United States</b>		<b>Coefficient of discharge K</b>			
ASME Sec. VIII Div. 1	Approval No.	M37044			
	S/G	0.699			
	Approval No.	M37055			
	L	0.521			
<b>Canada</b>		<b>Coefficient of discharge K</b>			
CRN	Approval No.	For current approval no. see <a href="http://www.leser.com">www.leser.com</a>			
	S/G	0.699			
	L	0.521			
<b>China</b>		<b>Coefficient of discharge α<sub>w</sub></b>			
AQSIQ	Approval No.	For current approval no. see <a href="http://www.leser.com">www.leser.com</a>			
	S/G	0.75	0.7	0.7	0.7
	L	0.56	0.52	0.52	0.52
<b>Eurasian Custom Union</b>		<b>Coefficient of discharge α<sub>w</sub></b>			
EAC	Approval No.	For current approval no. see <a href="http://www.leser.com">www.leser.com</a>			
	S/G	0.75	0.7	0.7	0.7
	L	0.56	0.52	0.52	0.52
<b>Classification societies</b>		<b>Homepage</b>			
Bureau Veritas	BV	<a href="http://www.bureauveritas.com">www.bureauveritas.com</a>		The valid certification number is changed with every renewal.	
DNV GL		<a href="http://www.dnvgl.com">www.dnvgl.com</a>			
Lloyd' s Register EMEA	LREMEA	<a href="http://www.lr.org">www.lr.org</a>		For a sample certificate including the valid certification number see <a href="http://www.leser.com">www.leser.com</a>	
Registro Italiano Navale	RINA	<a href="http://www.rina.org">www.rina.org</a>			

**Type 441, 442 XXL**  
**Available options**

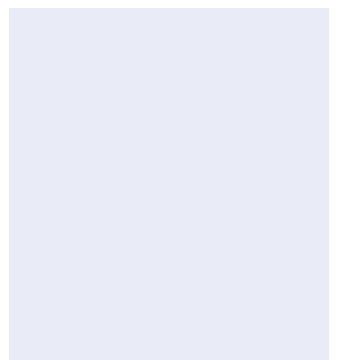
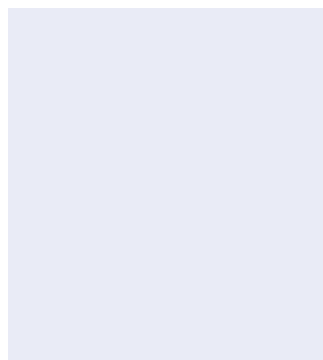
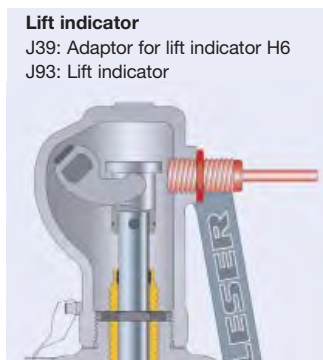
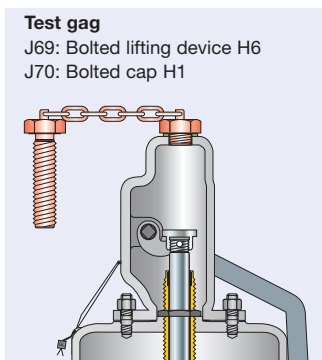
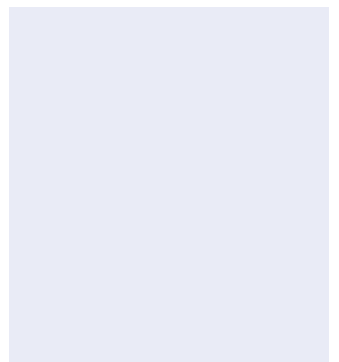
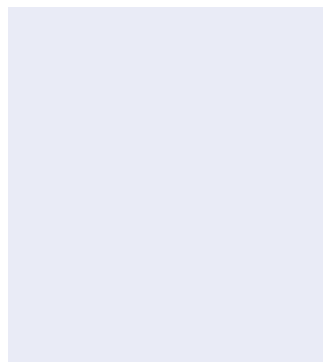
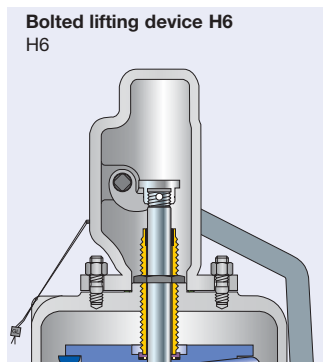
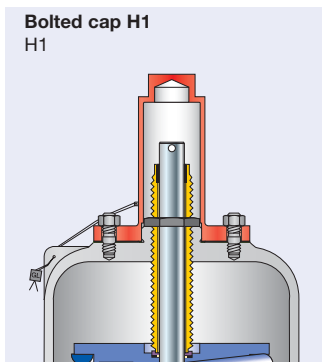
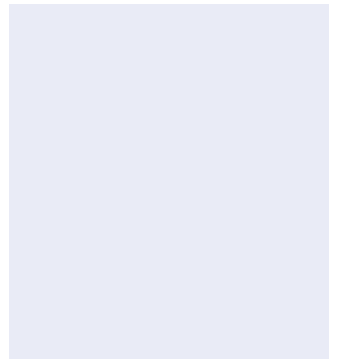
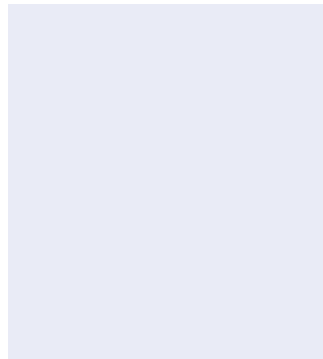
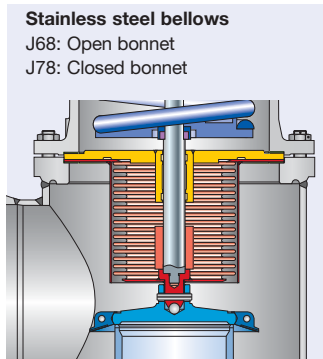
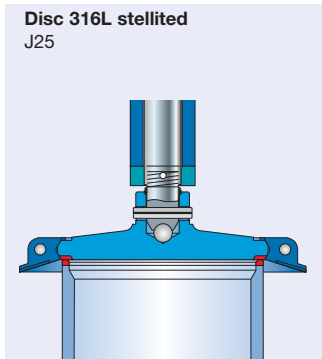
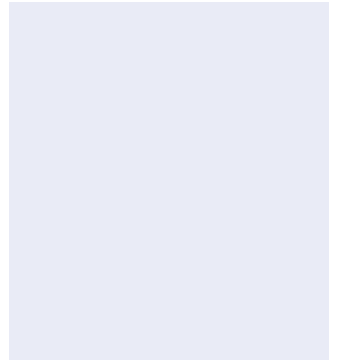
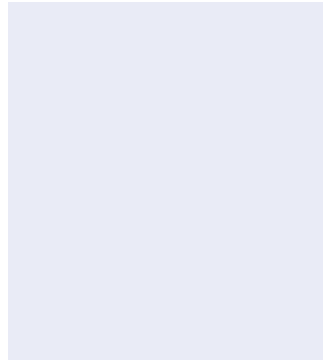
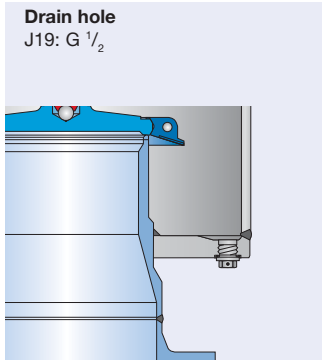

Type 441, 442  
 XXL



**Type 444**  
 Packed lever H4  
 Closed bonnet  
 Conventional design

**Type 444 DIN**  
**Type 444 ANSI**  
**Flanged Safety Relief Valves**

<b>Contents</b>	<b>Page</b>
<b>Materials</b>	
• Conventional design	65
<b>Article numbers</b>	67
<b>Dimensions and weights</b>	
• Metric Units + US Units	68
<b>Pressure temperature ratings</b>	
• Metric Units + US Units	69
Flange drillings and facings	70
Approvals	71
Available options	72



**Type 444 DIN, 444 ANSI**  
**Conventional design**

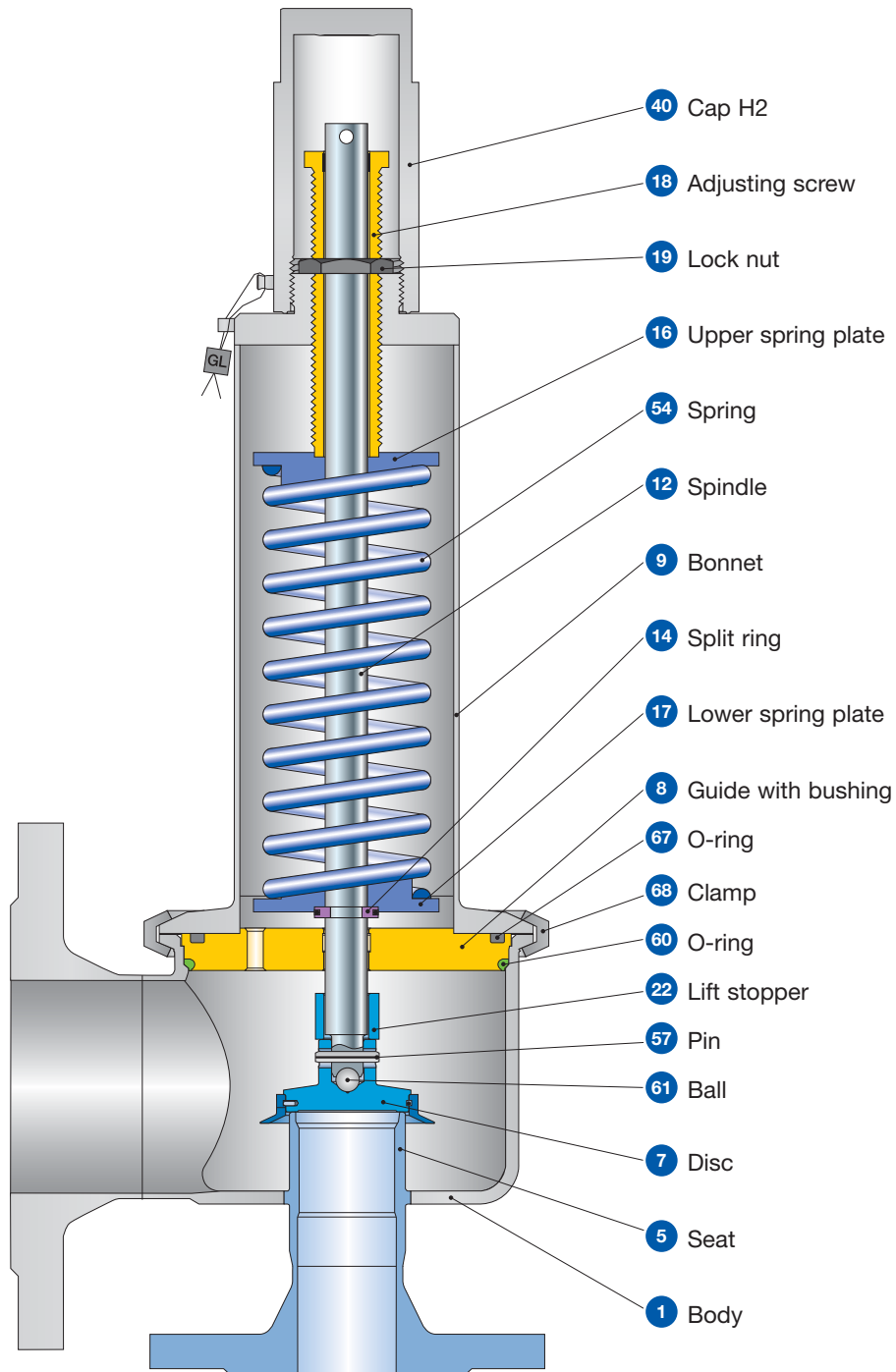

Type 444

## Type 444 DIN, ANSI

### Conventional design

#### Materials

Item	Component	Type 4444 DIN, ANSI
1	Body	1.4404
		SA 479 316L
5	Seat	1.4404
		316L
7	Disc	1.4404
		316L
8	Guide with bushing	1.4404
		316L
		PTFE +15% glass
		PTFE +15% glass
9	Bonnet	1.4404
		SA 479 316L
12	Spindle	1.4404
		316L
14	Split ring	1.4404
		316L
16 / 17	Spring plate	1.4404
		316L
18	Adjusting screw with bushing	1.4404, PTFE + 15% glass
		316L, PTFE + 15% glass
19	Lock nut	1.4404
		316L
22	Lift stopper	1.4404
		316L
40	Cap H2	1.4404
		316L
54	Spring	1.4310
		Stainless steel
57	Pin	1.4310
		302
60	O-ring	EPDM-FDA
		EPDM-FDA
61	Ball	1.4401
		316
67	O-ring	EPDM-FDA
		EPDM-FDA
68	Clamp	1.4401
		316

**Please notice:**

- Modifications reserved by LESER.
- LESER can upgrade materials without notice.
- Every part can be replaced by other material acc. to customer specification.

## Type 444 DIN, 444 ANSI

### Article numbers

#### Type 444 DIN

	DN <sub>i</sub>	25	40	50	65	80	80
	DN <sub>o</sub>	50	80	80	100	100	100
	Actual Orifice diameter d <sub>o</sub> [mm]	23	37	46	60	74	74
	Actual Orifice area A <sub>o</sub> [mm <sup>2</sup> ]	416	1075	1662	2827	4301	4301
	Set pressure range S/G/L [bar <sub>g</sub> ]	See page 69				0.1 – 6.8	6.81 – 16
	Set pressure range S/G/L [psig]	See page 69				1.5 – 98.6	98.61 – 232
<b>Body material: 1.4404 (316L)</b>							
<b>Bonnet closed</b>	<b>H2</b>	Art. No. <b>4444.</b>	<b>3642</b>	<b>3662</b>	<b>3672</b>	<b>3682</b>	<b>3702</b>
	<b>H4</b>	Art. No. <b>4444.</b>	<b>3644</b>	<b>3664</b>	<b>3674</b>	<b>3684</b>	<b>3704</b>

#### Type 444 ANSI

	Valve size	1" x 2"	1½" x 3"	2" x 3"	2½" x 4"	3" x 4"	3" x 4"
	Actual Orifice diameter d <sub>o</sub> [mm]	23	37	46	60	74	74
	Actual Orifice area A <sub>o</sub> [mm <sup>2</sup> ]	416	1075	1662	2827	4301	4301
	Set pressure range S/G/L [bar <sub>g</sub> ]	See page 69				0.1 – 6.8	6.81 – 16
	Set pressure range S/G/L [psig]	See page 69				1.5 – 98.6	98.61 – 232
<b>Body material: 1.4404 (316L)</b>							
<b>Bonnet closed</b>	<b>H2</b>	Art. No. <b>4444.</b>	<b>8902</b>	<b>8922</b>	<b>8932</b>	<b>8942</b>	<b>8962</b>
	<b>H4</b>	Art. No. <b>4444.</b>	<b>8904</b>	<b>8924</b>	<b>8934</b>	<b>8944</b>	<b>8964</b>

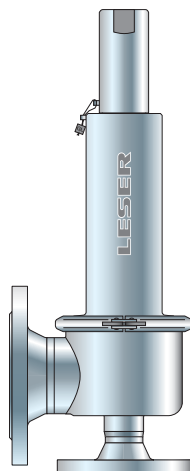

**Type 444**  
Cap H2  
Closed bonnet  
Conventional design

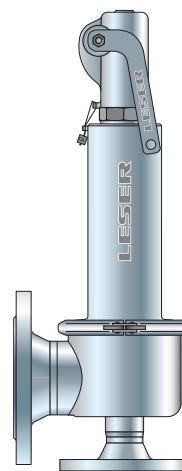

**Type 444**  
Packed lever H4  
Closed bonnet  
Conventional design

## Type 444 DIN, 444 ANSI Dimensions and weights

### Metric Units

	DN <sub>i</sub>	25	40	50	65	80	80
	DN <sub>o</sub>	50	80	80	100	100	100
	Valve size	1" x 2"	1½" x 3"	2" x 3"	2½" x 4"	3" x 4"	3" x 4"
	Actual Orifice diameter d <sub>0</sub> [mm]	23	37	46	60	74	74
	Actual Orifice area A <sub>0</sub> [mm <sup>2</sup> ]	416	1075	1662	2827	4301	4301
	Set pressure range S/G/L [bar <sub>g</sub> ]	See page 69				0.1 – 6.8	6.81 – 16
<b>Weight [kg]</b>		7	13	14	23	24	24
<b>Center to face [mm]</b>	Inlet a	85	110	110	125	125	125
	Outlet b	90	128	128	160	160	160
<b>Height (H4) [mm]</b>	Standard H max.	308	519	519	631	631	631

#### Body material: 1.4404 (316L)

<b>DIN Flange</b>	Inlet / Outlet	PN 16
<b>ANSI Flange Class</b>	Inlet / Outlet	CL150

### US Units

	DN <sub>i</sub>	25	40	50	65	80	80
	DN <sub>o</sub>	50	80	80	100	100	100
	Valve size	1" x 2"	1½" x 3"	2" x 3"	2½" x 4"	3" x 4"	3" x 4"
	Actual Orifice diameter d <sub>0</sub> [inch]	0.91	1.46	1.81	2.36	2.91	2.91
	Actual Orifice area A <sub>0</sub> [inch <sup>2</sup> ]	0.644	1.667	2.576	4.383	6.666	6.666
	Set pressure range S/G/L [psig]	See page 69				1.5 – 98.6	98.61 – 232
<b>Weight [lbs]</b>		16	29	31	51	53	53
<b>Center to face [inch]</b>	Inlet a	3 <sup>3</sup> / <sub>8</sub>	4 <sup>5</sup> / <sub>16</sub>	4 <sup>5</sup> / <sub>16</sub>	4 <sup>15</sup> / <sub>16</sub>	4 <sup>15</sup> / <sub>16</sub>	4 <sup>15</sup> / <sub>16</sub>
	Outlet b	3 <sup>1</sup> / <sub>2</sub>	5 <sup>1</sup> / <sub>16</sub>	5 <sup>1</sup> / <sub>16</sub>	6 <sup>5</sup> / <sub>16</sub>	6 <sup>5</sup> / <sub>16</sub>	6 <sup>5</sup> / <sub>16</sub>
<b>Height (H4) [inch]</b>	Standard H max.	12 <sup>1</sup> / <sub>8</sub>	20 <sup>7</sup> / <sub>16</sub>	20 <sup>7</sup> / <sub>16</sub>	20 <sup>13</sup> / <sub>16</sub>	20 <sup>13</sup> / <sub>16</sub>	20 <sup>13</sup> / <sub>16</sub>

#### Body material: 1.4404 (316L)

<b>DIN Flange</b>	Inlet / Outlet	PN 16
<b>ANSI Flange Class</b>	Inlet / Outlet	CL150

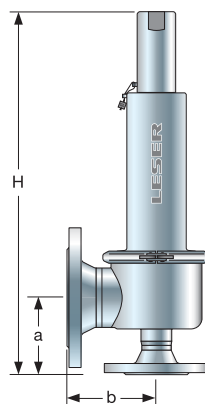

Conventional design

## Type 444 DIN, 444 ANSI

### Pressure temperature ratings

#### Metric Units

	DN <sub>i</sub>	25	40	50	65	80	80
	DN <sub>o</sub>	50	80	80	100	100	100
	Valve size	1" x 2"	1½" x 3"	2" x 3"	2½" x 4"	3" x 4"	3" x 4"
	Actual Orifice diameter d <sub>0</sub> [mm]	23	37	46	60	74	74
	Actual Orifice area A <sub>0</sub> [mm <sup>2</sup> ]	416	1075	1662	2827	4301	4301
<b>Body material: 1.4404 (316L)</b>							
<b>DIN Flange</b>	Inlet / Outlet						PN 16
<b>ANSI Flange Class<sup>1)</sup></b>	Inlet / Outlet						CL150
<b>Minimum set pressure</b>	p [bar <sub>g</sub> ] S/G/L	0.1	0.1	0.1	0.1	0.1	6.81
<b>Maximum set pressure</b>	p [bar <sub>g</sub> ] S/G/L	16	16	16	16	6.8	16
<b>Temperature acc. to DIN EN</b>	min. [°C]						-45
	max. [°C]						+200
<b>Temperature acc. to ASME</b>	min. [°C]						-45
	max. [°C]						+200

#### US Units

	DN <sub>i</sub>	25	40	50	65	80	80
	DN <sub>o</sub>	50	80	80	100	100	100
	Valve size	1" x 2"	1½" x 3"	2" x 3"	2½" x 4"	3" x 4"	3" x 4"
	Actual Orifice diameter d <sub>0</sub> [inch]	0.91	1.46	1.81	2.36	2.91	2.91
	Actual Orifice area A <sub>0</sub> [inch <sup>2</sup> ]	0.644	1.667	2.576	4.383	6.666	6.666
<b>Body material: 1.4404 (316L)</b>							
<b>DIN Flange</b>	Inlet / Outlet						PN 16
<b>ANSI Flange Class<sup>1)</sup></b>	Inlet / Outlet						CL150
<b>Minimum set pressure</b>	p [psig] S/G/L	1.5	1.5	1.5	1.5	1.5	98.61
<b>Maximum set pressure</b>	p [psig] S/G/L	232	232	232	232	98.6	232
<b>Temperature acc. to DIN EN</b>	min. [°F]						-49
	max. [°F]						+392
<b>Temperature acc. to ASME</b>	min. [°F]						-49
	max. [°F]						+392

<sup>1)</sup> For flange rating class 150 the pressure temperature ratings according to ASME ANSI B 16.34 apply.

## Type 444 DIN, 444 ANSI Flange drillings

	DN <sub>i</sub>	25	40	50	65	80
	DN <sub>o</sub>	50	80	80	100	100
	Valve size	1" x 2"	1½" x 3"	2" x 3"	2½" x 4"	3" x 4"
	Actual Orifice diameter d <sub>o</sub> [mm]	23	37	46	60	74
	Actual Orifice area A <sub>o</sub> [mm <sup>2</sup> ]	416	1075	1662	2827	4301
<b>Body material: 1.4404 (316L)</b>						
<b>Inlet</b>	<b>DIN EN 1092</b>	PN 10	–	–	–	–
		PN 16	*	*	*	*
		PN 25	–	–	–	–
		PN 40	–	–	–	–
	<b>ASME B16.5</b>	CL150	*	*	*	*
		CL300	–	–	–	–
<b>Outlet</b>	<b>DIN EN 1092</b>	PN 10	–	–	–	–
		PN 16	*	*	*	*
		PN 25	–	–	–	–
		PN 40	–	–	–	–
	<b>ASME B16.5</b>	CL150	*	*	*	*
		CL300	–	–	–	–

## Flange facings

Indication	Standard	Inlet	Outlet	Remark						
<b>General</b>										
Flange undrilled	–	H38	H39							
Linde-V-Nut, Form V48	Linde Standard 420-08	J07	J08	Groove: Rz 16						
Linde-V-Nut, Form V48A	LDeS 3313.36	J05	J06	Groove: Rz 4, e.g. with hydrogen						
Lens seal form L (without sealing lens)	DIN 2696 LDeS 3313.35	J11	J12							
<b>Acc. to DIN EN 1092</b>										
<b>Flange facing</b> (see also LDeS 3313.40)		PN 10 – PN 40	PN 10 – PN 40	Rz-data according to DIN EN 1092 in µm						
Raised face	Type B1	*	*	Facing: Rz = 12.5 – 50						
	Type B2	L36	L38	Facing: Rz = 3.2 – 12.5						
Tongue face C <sup>1)</sup>		H94	H92	Steel flanges only						
Groove face D <sup>1)</sup>		H93	H91							
Male face E		H96	H98							
Female face F		H97	H99							
O-ring male face G		J01	J02							
O-ring female face H		J03	J04							
<b>Acc. to ASME B16.5</b>										
Body material	Inlet	Outlet	Smooth finish <sup>2)</sup>		Serrated finish		RTJ-Groove			
			Inlet	Outlet	Inlet	Outlet	Inlet		Outlet	
			Option code		Option code		RTJ- Class	Option code	RTJ- Class	Option code
1.4404	all	all	L52	L53	*	*	CL150	H62	CL150	H63

<sup>1)</sup> LESER manufactures the groove at flanged valves by milling. If a customer demands a turned surface in the soil of the groove according to DIN EN 1092-1 an additional option code is necessary: "S01: soil of the groove drilled".

<sup>2)</sup> Smooth finish is not defined in the effective standards.

Note: Flange drillings and facings meet always the requirements of mentioned flange standards.  
Flange thickness and outer diameter may vary from flange standard.

## Type 444 DIN, 444 ANSI

### Approvals

	DN <sub>i</sub>	25	40	50	65	80	80
	DN <sub>o</sub>	50	80	80	100	100	100
	Valve size	1" x 2"	1½" x 3"	2" x 3"	2½" x 4"	3" x 4"	3" x 4"
	Actual Orifice diameter d <sub>o</sub> [mm]	23	37	46	60	74	74
	Actual Orifice area A <sub>o</sub> [mm <sup>2</sup> ]	416	1075	1662	2827	4301	4301
	Set pressure range S/G/L [bar <sub>g</sub> ]	See page 69				0.1 – 6.8	6.81 – 16
	Set pressure range S/G/L [psig]					1.5 – 98.6	98.61 – 232
<b>Europe</b>		<b>Coefficient of discharge K<sub>dr</sub></b>					
PED / DIN EN ISO 4126-1 12/2013	Approval No.	072020111Z0008/0/08 Rev.3					
	S/G	0.7					0.55
	F	0.48					0.48
<b>Germany</b>		<b>Coefficient of discharge α<sub>w</sub></b>					
PED / AD 2000-Merkblatt A2 07/2012	Approval No.	TÜV SV 576					
	S/G	0.7					0.55
	F	0.48					0.48
<b>United States</b>		<b>Coefficient of discharge K</b>					
ASME Sec. VIII Div. 1	Approval No.	M37044					–
	S/G	0.699					–
	Approval No.	M37055					M37055
	F	0.521					0.521
<b>Canada</b>		<b>Coefficient of discharge K</b>					
CRN	Approval No.	For current approval no. see www.leser.com					
	S/G	0.699					–
	F	0.521					0.521
<b>China</b>		<b>Coefficient of discharge α<sub>w</sub></b>					
AQSIQ	Approval No.	For current approval no. see www.leser.com					
	S/G	0.7					0.55
	F	0.48					0.48
<b>Eurasian Custom Union</b>		<b>Coefficient of discharge α<sub>w</sub></b>					
EAC	Approval No.	For current approval no. see www.leser.com					
	S/G	0.7					0.55
	F	0.48					0.48
<b>Classification societies</b>							
		on request					

**Type 444 DIN, 444 ANSI**

**Available Options**

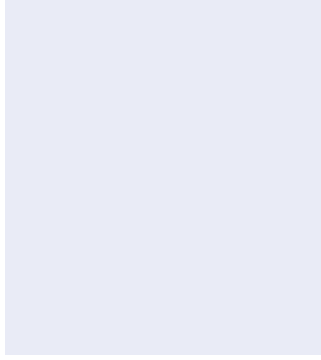
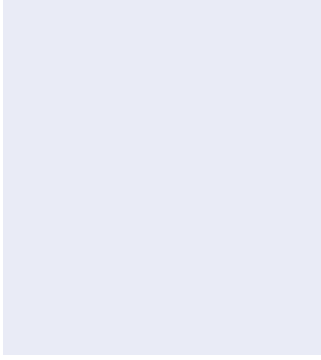
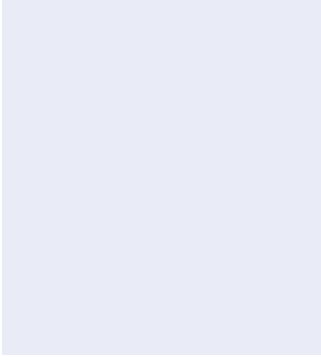
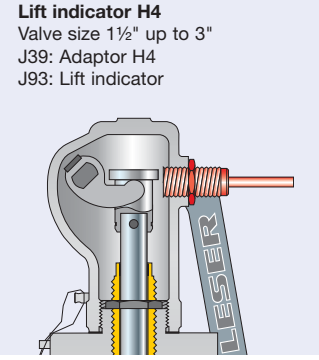
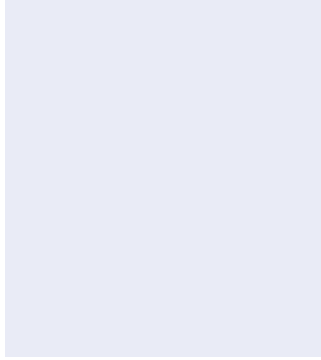
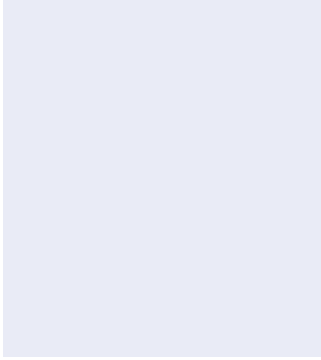
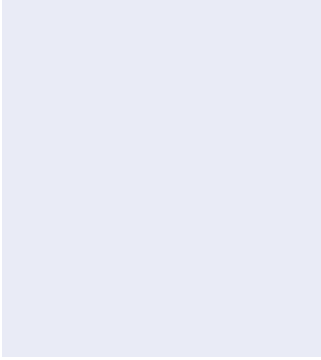
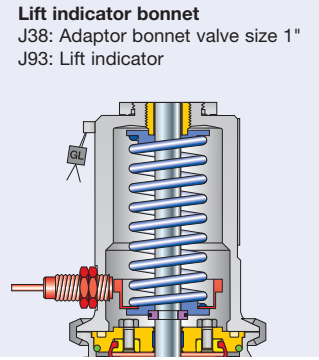
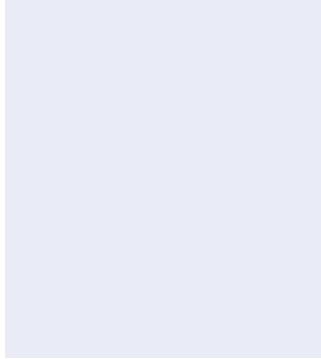
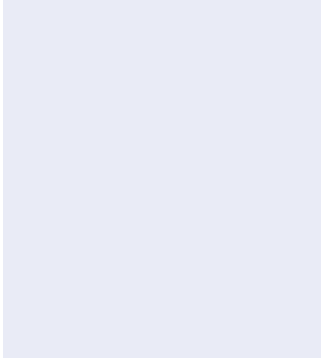
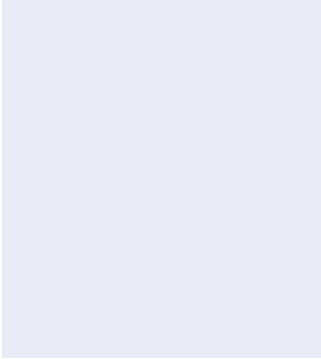
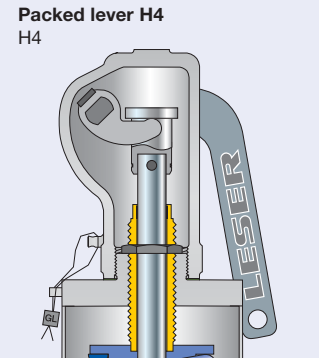
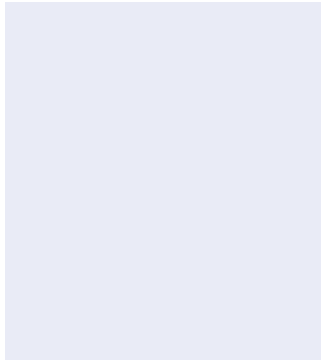
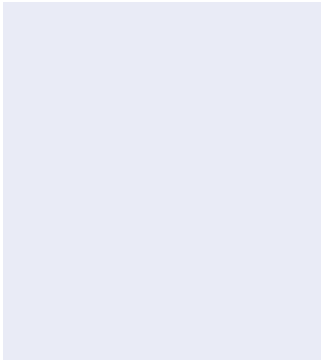
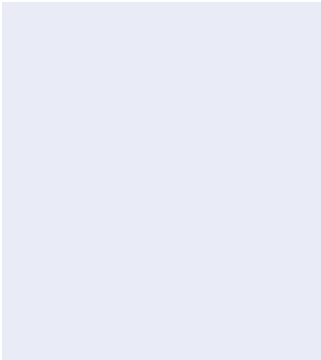
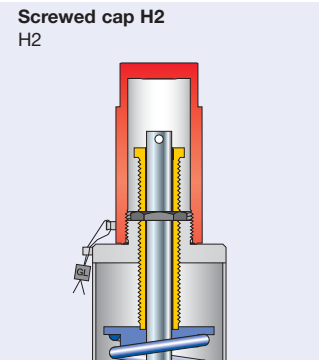

Type 444





**Type 456**  
 Packed lever H4  
 Closed bonnet  
 Conventional design

**Type 455, 456**  
**Flanged Safety Relief Valves**

<b>Contents</b>	<b>Page</b>
<b>Materials</b>	
• Conventional design	74
• Balanced bellows design	76
<b>Article numbers</b>	78
<b>Dimensions and weights</b>	
• Metric Units	79
• US Units	80
<b>Pressure temperature ratings</b>	
• Metric Units	81
• US Units	82
Flange drillings	83
Flange facings	84
Approvals	85
Available options	86

**Type 455, 456**  
**Conventional design**

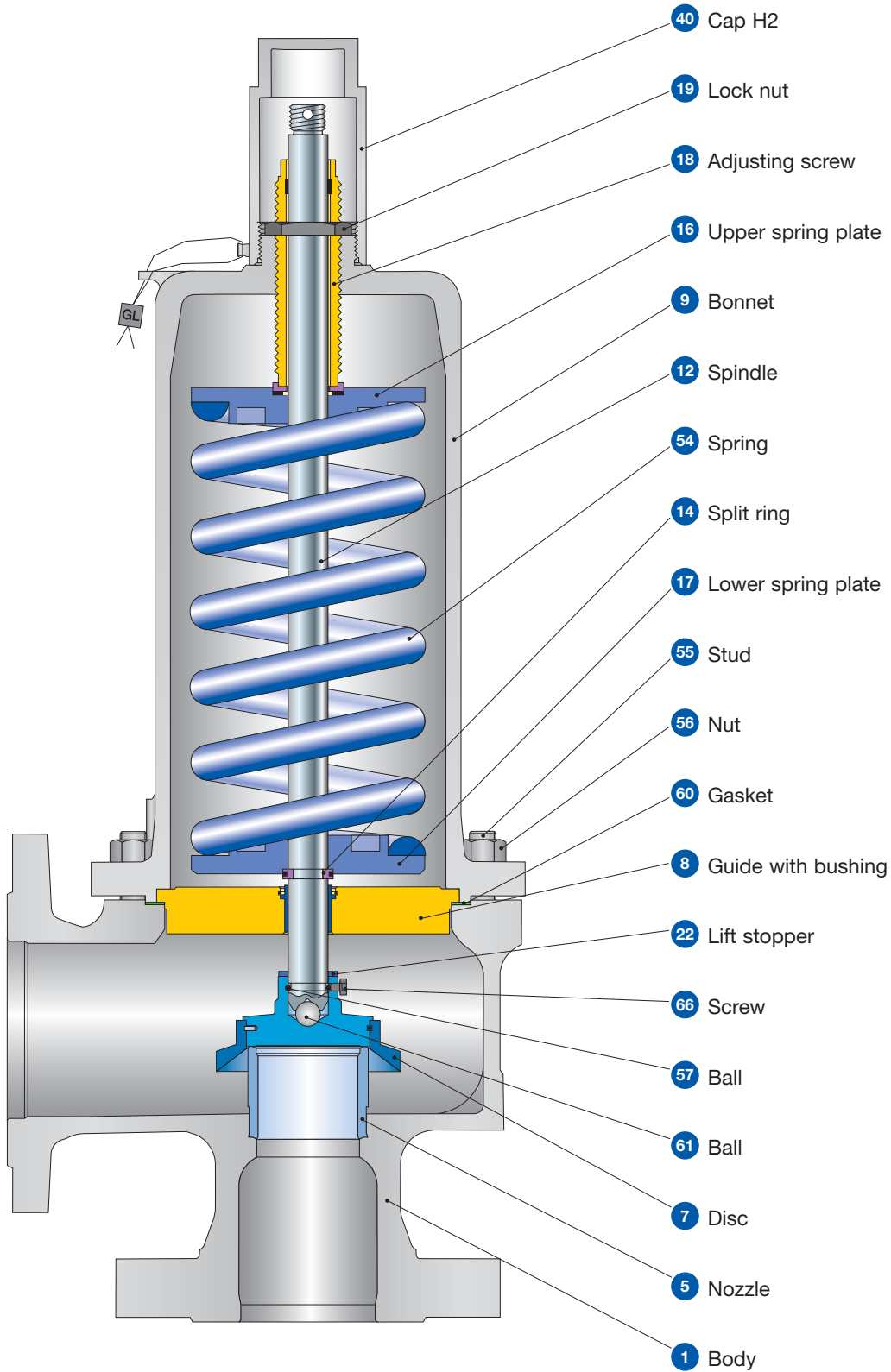

Type 455, 456

## Type 455, 456

### Conventional design

#### Materials

Item	Component	Type 4552 / 4562	Type 4564
1	Body	1.0619	1.4581
		SA 216 WCB	SA 351 CF10M
5	Seat	1.4404	1.4404
		316L	316L
7	Disc	1.4122	1.4404
		Hardened stainless steel	316L
8	Guide with bushing	1.0501, 0.7040	1.4404
		Chrome or carbon steel	316L
		1.4104 tenifer	-
		Chrome steel	-
9	Bonnet	0.7043 (Open bonnet 0.7040), 1.0619	1.4408, 1.4404, 1.4571
		Ductile Gr. 60-40-18, SA 216 WCB	SA 351 CF8M, SA 479 316L, 316Ti
12	Spindle	1.4404	1.4404
		316L	316L
14	Split ring	1.4104	1.4404
		Chrome steel	316L
16 / 17	Spring plate	1.0718	1.4404
		Steel	316L
18	Adjusting screw with bushing	1.4104 PTFE	1.4404 PTFE
		Chrome steel PTFE	316L PTFE
19	Lock nut	1.0718	1.4404
		Steel	316L
22	Lift stopper	1.4404	1.4404
		316L	316L
40	Cap H2	1.0460	1.4404
		SA 105	316L
54	Spring standard	1.1200, 1.8159, 1.7102	1.4310
		Carbon steel	Stainless steel
	Spring optional	1.4310	-
		Stainless steel	-
55	Stud	1.4401	1.4401
		B8M	B8M
56	Nut	1.4401	1.4401
		8M	8M
57	Ball	1.4401	1.4401
		316	316
60	Gasket	Graphite / 1.4401	Graphite / 1.4401
		Graphite / 316	Graphite / 316
61	Ball	1.3541	1.4401
		Hardened stainless steel	316
66	Screw	1.4401	1.4401
		B8M	B8M

**Please notice:**

- Modifications reserved by LESER.
- LESER can upgrade materials without notice.
- Every part can be replaced by other material acc. to customer specification.

**Type 455, 456**  
**Balanced bellows design**

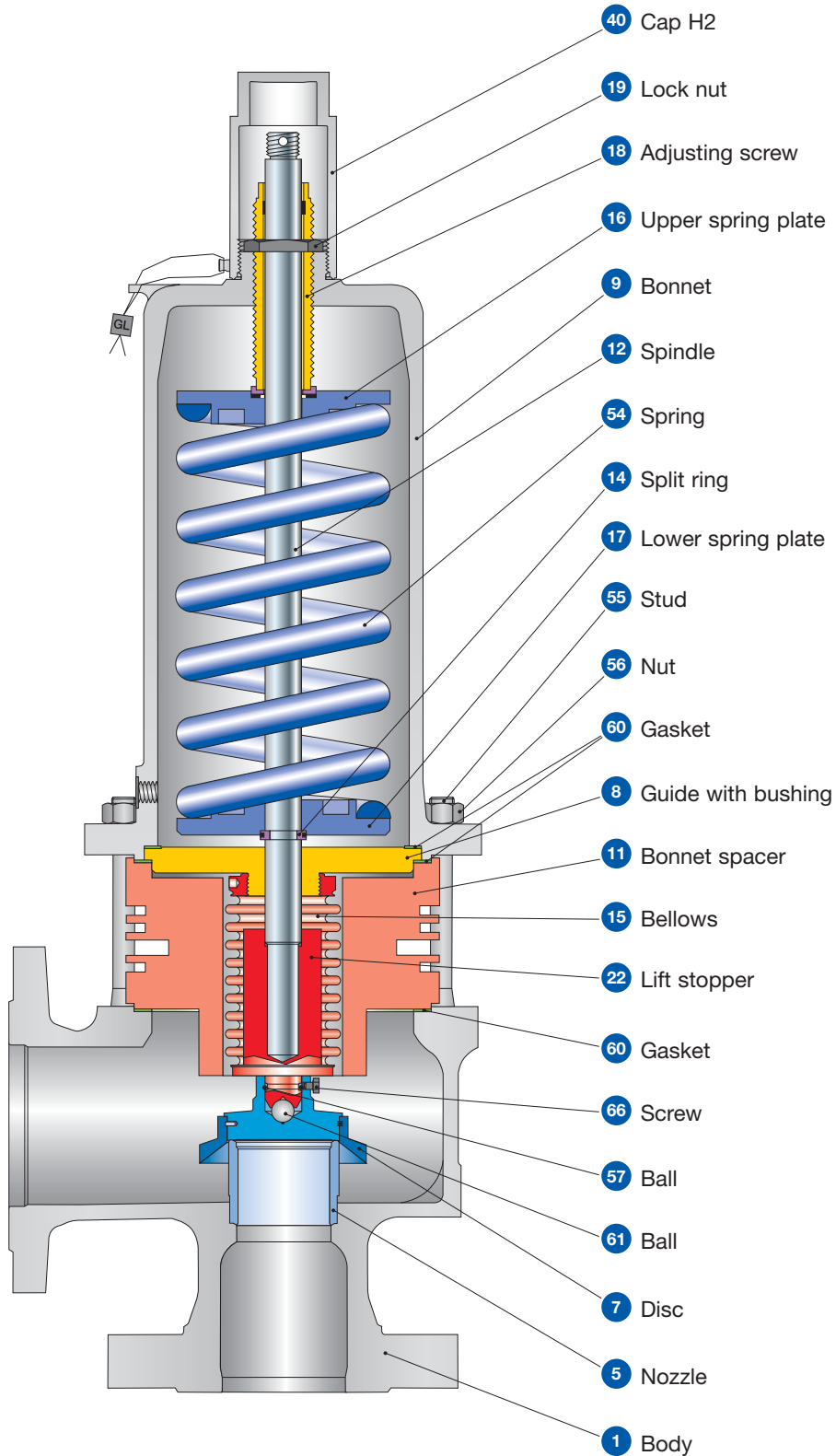

Type 455, 456

## Type 455, 456

### Balanced bellows design

#### Materials

Item	Component	Type 4552 / 4562	Type 4564
1	Body	1.0619	1.4581
		SA 216 WCB	SA 351 CF10M
5	Nozzle	1.4404	1.4404
		316L	316L
7	Disc	1.4122	1.4404
		Hardened stainless steel	316L
8	Guide with bushing	1.0501, 0.7040	1.4404
		Chrome or carbon steel	316L
		1.4104 tenifer	-
		Chrome steel	-
9	Bonnet	0.7043 or 1.0619	1.4408, 1.4404, 1.4571
		Ductile Gr. 60-40-18 or SA 216 WCB	SA 351 CF8M, SA 479 316L, 316Ti
11	Bonnet spacer	1.0460	1.4404
		Carbon steel	316L
12	Spindle	1.4404	1.4404
		316L	316L
14	Split ring	1.4104	1.4404
		Chrome steel	316L
15	Bellows	1.4571	1.4571
		316Ti	316Ti
16 / 17	Spring plate	1.0718	1.4404
		Steel	316L
18	Adjusting screw with bushing	1.4104 PTFE	1.4404 PTFE
		Chrome steel PTFE	316L PTFE
19	Lock nut	1.0718	1.4404
		Steel	316L
22	Lift stopper	1.4404	1.4404
		316L	316L
40	Cap H2	1.0460	1.4404
		SA 105	316L
54	Spring Standard	1.1200, 1.8159, 1.7102	1.4310
		Carbon steel	Stainless steel
55	Stud	1.7709	1.4401
		B16	B8M
56	Nut	1.7258	1.4401
		7M	8M
57	Ball	1.4401	1.4401
		316	316
60	Gasket	Graphite / 1.4401	Graphite / 1.4401
		Graphite / 316	Graphite / 316
61	Ball	1.3541	1.4401
		Hardened stainless steel	316
66	Screw	1.4401	1.4401
		B8M	B8M

**Please notice:**

- Modifications reserved by LESER.
- LESER can upgrade materials without notice.
- Every part can be replaced by other material acc. to customer specification.

## Type 455, 456

### Article numbers

	DN <sub>I+O</sub>	25 x 50	50 x 80	80 x 100	100 x 150	
Valve size		1" x 2"	2" x 3"	3" x 4"	4" x 6"	
Actual Orifice diameter d <sub>0</sub> [mm]		20	40	60	74	
Actual Orifice area A <sub>0</sub> [mm <sup>2</sup> ]		314	1257	2827	4301	
<b>Body material: 1.0619 (WCB)</b>						
<b>Bonnet</b>	<b>H2</b>	Art. No. <b>4562.</b>	<b>6012</b>	<b>6022</b>	<b>6032</b>	<b>6042</b>
closed	<b>H3</b>	Art. No. <b>4562.</b>	<b>6013</b>	<b>6023</b>	<b>6033</b>	-
	<b>H4</b>	Art. No. <b>4562.</b>	<b>6014</b>	<b>6024</b>	<b>6034</b>	<b>6044</b>
open	<b>H3</b>	Art. No. <b>4552.</b>	<b>6015</b>	<b>6025</b>	<b>6035</b>	<b>6045</b>
<b>Body material: 1.4581 (CF10M)</b>						
<b>Bonnet</b>	<b>H2</b>	Art. No. <b>4564.</b>	<b>6052</b>	<b>6062</b>	<b>6072</b>	<b>6082</b>
closed	<b>H4</b>	Art. No. <b>4564.</b>	<b>6054</b>	<b>6064</b>	<b>6074</b>	<b>6084</b>

Type 455, 456

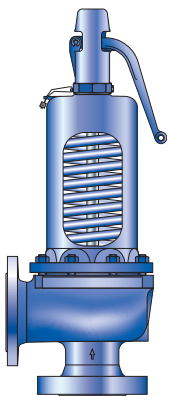

**Type 455**  
Plain lever H3  
Open bonnet  
Conventional design

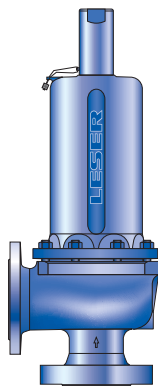

**Type 456**  
Cap H2  
Closed bonnet  
Conventional design

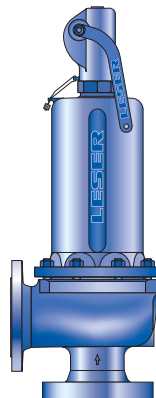

**Type 456**  
Packed lever H4  
Closed bonnet  
Conventional design

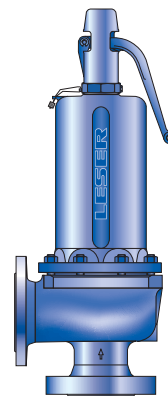

**Type 456**  
Plain lever H3  
Closed bonnet  
Conventional design

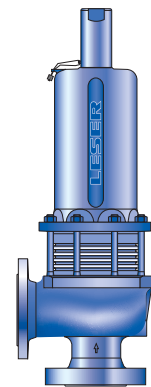

**Type 456**  
Cap H2  
Closed bonnet  
Balanced bellows design

## Type 455, 456

### Dimensions and weights

Metric Units

DN <sub>I+O</sub>		25 x 50	50 x 80	80 x 100	100 x 150
Valve size		1" x 2"	2" x 3"	3" x 4"	4" x 6"
Actual Orifice diameter d <sub>0</sub> [mm]		20	40	60	74
Actual Orifice area A <sub>0</sub> [mm <sup>2</sup> ]		314	1257	2827	4301
<b>Weight</b>					
[kg]		18	43	85	154
	with bellows	20	46	102	185
<b>Center to face</b>					
[mm]	Inlet a	122	155	175	210
	Outlet b (PN 40)	120	145	180	235
	Outlet b (PN 63)	120	145	205	265
<b>Measure</b> Used to find bolt length for inlet flange		s			
[mm]		28	38	38	45
<b>Height (H4)</b>					
[mm]	Standard H max.	493	684	807	1059
	Bellows H max.	528	764	905	1150
<b>Support brackets</b>					
[mm]	A	140	184	278	364
	B	-	110	160	210
	C	Ø 14	Ø 14	Ø 18	Ø 18
	D	149	194	225	288
	E	18	18	27	32
<b>Body material: 1.0619 (WCB)</b>					
<b>DIN Flange<sup>1)</sup></b>		Inlet	PN 63 – 160		
	Outlet	PN 40 – 63			PN 40
<b>Body material: 1.4581 (CF10M)</b>					
<b>DIN Flange<sup>1)</sup></b>		Inlet	PN 63 – 160		
	Outlet	PN 40 – 63			PN 40

<sup>1)</sup> Standard flange rating. For other flange drillings please refer to page 83.

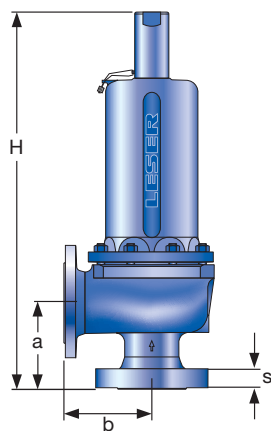

Conventional design

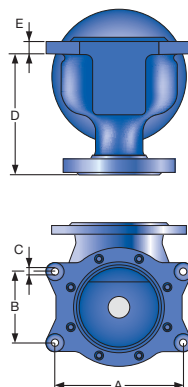

Support brackets

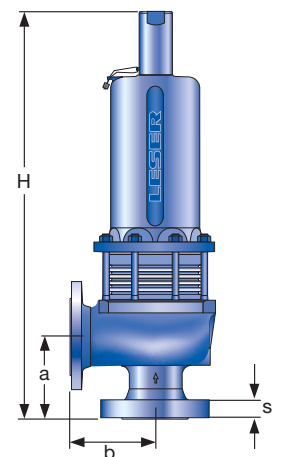

Balanced bellows design

## Type 455, 456

### Dimensions and weights

US Units

	DN <sub>I+O</sub>	25 x 50	50 x 80	80 x 100	100 x 150
Valve size		1" x 2"	2" x 3"	3" x 4"	4" x 6"
Actual Orifice diameter d <sub>0</sub> [inch]		0.79	1.57	2.36	2.91
Actual Orifice area A <sub>0</sub> [inch <sup>2</sup> ]		0.487	1.948	4.383	6.666
<b>Weight</b> [lbs]		40	95	187	340
	with bellows	44	101	225	408
<b>Center to face</b> [inch]	Inlet a	4 <sup>13</sup> / <sub>16</sub>	6 <sup>3</sup> / <sub>32</sub>	6 <sup>7</sup> / <sub>8</sub>	8 <sup>1</sup> / <sub>4</sub>
	Outlet b (PN 40)	4 <sup>23</sup> / <sub>32</sub>	5 <sup>23</sup> / <sub>32</sub>	7 <sup>3</sup> / <sub>32</sub>	9 <sup>1</sup> / <sub>4</sub>
	Outlet b (PN 63)	4 <sup>23</sup> / <sub>32</sub>	5 <sup>23</sup> / <sub>32</sub>	8 <sup>1</sup> / <sub>16</sub>	10 <sup>7</sup> / <sub>16</sub>
<b>Measure</b> [inch]	Used to find bolt length for inlet flange s	1 <sup>3</sup> / <sub>32</sub>	1 <sup>1</sup> / <sub>2</sub>	1 <sup>1</sup> / <sub>2</sub>	1 <sup>25</sup> / <sub>32</sub>
<b>Height (H4)</b> [inch]	Standard H max.	19 <sup>23</sup> / <sub>32</sub>	26 <sup>15</sup> / <sub>16</sub>	31 <sup>25</sup> / <sub>32</sub>	41 <sup>11</sup> / <sub>16</sub>
	Bellows H max.	20 <sup>25</sup> / <sub>32</sub>	30 <sup>3</sup> / <sub>32</sub>	35 <sup>5</sup> / <sub>8</sub>	45 <sup>1</sup> / <sub>4</sub>
<b>Support brackets</b> [inch]	A	5 <sup>1</sup> / <sub>2</sub>	7 <sup>1</sup> / <sub>4</sub>	10 <sup>5</sup> / <sub>16</sub>	4 <sup>11</sup> / <sub>32</sub>
	B	–	4 <sup>11</sup> / <sub>32</sub>	6 <sup>5</sup> / <sub>16</sub>	8 <sup>9</sup> / <sub>32</sub>
(drilled only on request, Option code H42)	C	Ø <sup>9</sup> / <sub>16</sub>	Ø <sup>9</sup> / <sub>16</sub>	Ø <sup>23</sup> / <sub>32</sub>	Ø <sup>23</sup> / <sub>32</sub>
	D	5 <sup>7</sup> / <sub>8</sub>	7 <sup>5</sup> / <sub>8</sub>	8 <sup>27</sup> / <sub>32</sub>	11 <sup>11</sup> / <sub>32</sub>
	E	<sup>23</sup> / <sub>32</sub>	<sup>23</sup> / <sub>32</sub>	1 <sup>1</sup> / <sub>16</sub>	1 <sup>1</sup> / <sub>4</sub>
<b>Body material: 1.0619 (WCB)</b>					
<b>ANSI Flange</b>	Inlet	CL300 – 600			
<b>Class<sup>1)</sup></b>	Outlet	CL150 – 300			CL150
<b>Body material: 1.4581 (CF10M)</b>					
<b>ANSI Flange</b>	Inlet	CL300 – 600			
<b>Class<sup>1)</sup></b>	Outlet	CL150 – 300			CL150

<sup>1)</sup> Standard flange rating. For other flange drillings please refer to page 83.

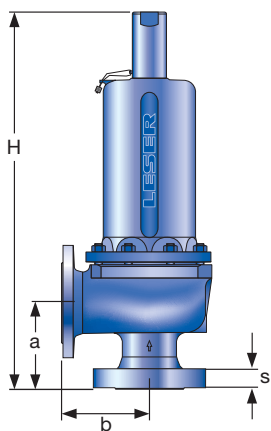

Conventional design

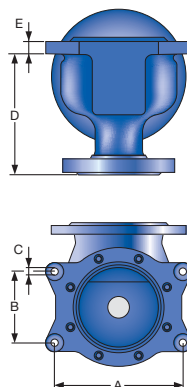

Support brackets

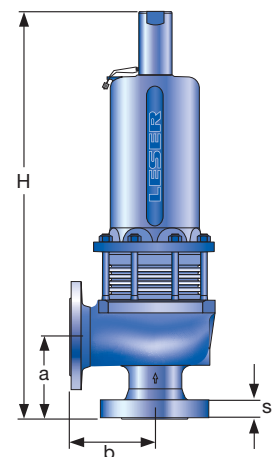

Balanced bellows design



## Type 455, 456

### Pressure temperature ratings

Metric Units

	DN <sub>I+O</sub>	25 x 50	50 x 80	80 x 100	100 x 150
	Valve size	1" x 2"	2" x 3"	3" x 4"	4" x 6"
	Actual Orifice diameter d <sub>0</sub> [mm]	20	40	60	74
	Actual Orifice area A <sub>0</sub> [mm <sup>2</sup> ]	314	1257	2827	4301
<b>Body material: 1.0619 (WCB)</b>					
<b>DIN Flange</b>	Inlet	<b>PN 63 – 100</b>			
	Outlet	<b>PN 40 – 63</b>		<b>PN 40</b>	
<b>Minimum set pressure</b>	p [bar <sub>g</sub> ] S/G/L	2.5	2.5	2.5	2.5
<b>Min. set pressure<sup>1)</sup> standard bellows</b>	p [bar <sub>g</sub> ] S/G/L	13.5	2.5	10	5
<b>Min. set pressure low press. bellows</b>	p [bar <sub>g</sub> ] S/G/L		on request		
<b>Maximum set pressure</b>	p [bar <sub>g</sub> ] S/G/L	100	98	63	53
<b>Max. set pressure with special spring</b>	p [bar <sub>g</sub> ] S/G/L	100	100	63	63
<b>Temperature acc. to DIN EN</b>	min. [°C]	-85			
	max. [°C]	+450			
<b>Temperature acc. to ASME</b>	min. [°C]	-29			
	max. [°C]	+427			

<b>Body material: 1.4581 (CF10M)</b>					
<b>DIN Flange</b>	Inlet	<b>PN 63 – 100</b>			
	Outlet	<b>PN 40 – 63</b>		<b>PN 40</b>	
<b>Minimum set pressure</b>	p [bar <sub>g</sub> ] S/G/L	2.5	2.5	2.5	2.5
<b>Min. set pressure<sup>1)</sup> standard bellows</b>	p [bar <sub>g</sub> ] S/G/L	13.5	2.5	10	5
<b>Min. set pressure low press. bellows</b>	p [bar <sub>g</sub> ] S/G/L		on request		
<b>Maximum set pressure</b>	p [bar <sub>g</sub> ] S/G/L	100	61	35	16.9
<b>Max. set pressure with special spring</b>	p [bar <sub>g</sub> ] S/G/L	100	65	43	43
<b>Temperature acc. to DIN EN</b>	min. [°C]	-85			
	max. [°C]	+450, > 450 °C → Please use Type 457/458			
<b>Temperature acc. to ASME</b>	min. [°C]	-29			
	max. [°C]	+450, > 450 °C → Please use Type 457/458			

<sup>1)</sup> Min. set pressure standard bellows = Max. set pressure low pressure bellows.

## Type 455, 456

### Pressure temperature ratings

US Units

	DN <sub>I+O</sub>	25 x 50	50 x 80	80 x 100	100 x 150
Valve size		1" x 2"	2" x 3"	3" x 4"	4" x 6"
Actual Orifice diameter d <sub>0</sub> [inch]		0.79	1.57	2.36	2.91
Actual Orifice area A <sub>0</sub> [inch <sup>2</sup> ]		0.487	1.948	4.383	6.666
<b>Body material: 1.0619 (WCB)</b>					
<b>ANSI Flange Class<sup>1)</sup></b>	Inlet	<b>CL300 – 600</b>			
	Outlet	<b>CL150 – 300</b>		<b>CL150</b>	
<b>Minimum set pressure</b>	p [psig] S/G/L	36	36	36	36
<b>Min. set pressure<sup>2)</sup> standard bellows</b>	p [psig] S/G/L	196	36	145	73
<b>Min. set pressure low press. bellows</b>	p [psig] S/G/L		on request		
<b>Maximum set pressure</b>	p [psig] S/G/L	1450	1421	914	769
<b>Max. set pressure with special spring</b>	p [psig] S/G/L	1450	1450	914	914
<b>Temperature acc. to DIN EN</b>	min. [°F]	-121			
	max. [°F]	+842			
<b>Temperature acc. to ASME</b>	min. [°F]	-20			
	max. [°F]	+800			

<b>Body material: 1.4581 (CF10M)</b>					
<b>ANSI Flange Class<sup>1)</sup></b>	Inlet	<b>CL300 – 600</b>			
	Outlet	<b>CL150 – 300</b>		<b>CL150</b>	
<b>Minimum set pressure</b>	p [psig] S/G/L	36	36	36	36
<b>Min. set pressure<sup>2)</sup> standard bellows</b>	p [psig] S/G/L	196	36	145	73
<b>Min. set pressure low press. bellows</b>	p [psig] S/G/L		on request		
<b>Maximum set pressure</b>	p [psig] S/G/L	1450	885	508	245
<b>Max. set pressure with special spring</b>	p [psig] S/G/L	1450	943	624	624
<b>Temperature acc. to DIN EN</b>	min. [°F]	-121			
	max. [°F]	+842, > 842 °F → Please use Type 457/458			
<b>Temperature acc. to ASME</b>	min. [°F]	-20			
	max. [°F]	+842, > 842 °F → Please use Type 457/458			

<sup>1)</sup> For flange rating class 150 the pressure temperature ratings according to ASME ANSI B16.34 apply.

<sup>2)</sup> Min. set pressure standard bellows = Max. set pressure low pressure bellows.

## Type 455, 456

### Flange drillings

	DN <sub>I+O</sub>	25 x 50	50 x 80	80 x 100	100 x 150	
	Valve size	1" x 2"	2" x 3"	3" x 4"	4" x 6"	
	Actual Orifice diameter d <sub>0</sub> [mm]	20	40	60	74	
	Actual Orifice area A <sub>0</sub> [mm <sup>2</sup> ]	314	1257	2827	4301	
<b>Body material: 1.0619 (WCB), 1.4581 (CF10M)</b>						
<b>Inlet</b>	<b>DIN EN 1092</b>	PN 16	H47	H47	H47	H47
		PN 25	H47	H47	H47	H47
		PN 40	H47	H47	H47	H47
		PN 63	*	H10	H10	H10
		PN 100	*	*	*	*
		PN 160	*	*	*	*
		PN 250	-	-	-	-
		PN 320	-	-	-	-
	PN 400	-	-	-	-	
	<b>ASME B16.5</b>	CL150	-	-	-	-
		CL300	H65	H65	H65	H65
		CL600	H67	H67	H67	H67
		CL900	H69	H69	-	-
		CL1500	H69	H69	-	-
		CL2500	-	-	-	-
	<b>Outlet</b>	<b>DIN EN 1092</b>	PN 10	*	*	H51
PN 16			*	*	H51	H51
PN 25			*	*	*	*
PN 40			*	*	*	*
PN 63			H16	H16	-	-
<b>ASME B16.5</b>		CL150	H79	H79	H79	H79
		CL300	H80	H80	-	-

## Type 455, 456

### Flange facings

Indication	Standard	Inlet		Outlet		Remark				
<b>General</b>										
Flange undrilled	–	H38		H39						
Linde-V-Nut, Type V48	Linde Standard 420-08 LDeS 3313.36	J07		J08		Groove: Rz 16				
Linde-V-Nut, Type V48A		J05		J06		Groove: Rz 4, e.g. with hydrogen				
Lens seal form L (without sealing lens)	DIN 2696 LDeS 3313.35	J11		J12						
<b>Acc. to DIN EN 1092</b>										
<b>Flange facing</b> (see LDeS 3313.40)		PN 10 – PN 40	PN 63	PN 10 – PN 40	PN 63	Rz-data according to DIN EN 1092 in µm				
Raised face	Type B1	*	–	*	–	Facing: Rz = 12.5 – 50				
	Type B2	L36	*	L38	*	Facing: Rz = 3.2 – 12.5				
Tongue face C <sup>1)</sup>		H94		H92		Steel flange only				
Groove face D <sup>1)</sup>		H93		H91						
Male face E		H96		H98						
Female face F		H97		H99						
O-ring male face G		J01		J02						
O-ring female face H		J03		J04						
<b>Acc. to ASME B16.5</b>										
Body material	Inlet	Outlet	Smooth finish <sup>2)</sup>		Serrated finish		RTJ-groove			
			Inlet	Outlet	Inlet	Outlet	Inlet		Outlet	
			Option code		Option code		RTJ- Class	Option code	RTJ- Class	Option code
1.0619, 1.4581	all	all	L52	L53	*	*	CL300 – 1500	H62	CL150	H63
							CL2500	–	CL300	H63

<sup>1)</sup> LESER manufactures the groove at flanged valves by milling. If a customer demands a turned surface in the soil of the groove according to DIN EN 1092-1 an additional option code is necessary: "S01: soil of the groove drilled".

<sup>2)</sup> Smooth finish is not defined in the effective standards.

Note: Flange drillings and facings meet always the requirements of mentioned flange standards.  
Flange thickness and outer diameter may vary from flange standard.

## Type 455, 456

### Approvals

	DN <sub>I+O</sub>	25 x 50	50 x 80	80 x 100	100 x 150
	Valve size	1" x 2"	2" x 3"	3" x 4"	4" x 6"
	Actual Orifice diameter d <sub>0</sub> [mm]	20	40	60	74
	Actual Orifice area A <sub>0</sub> [mm <sup>2</sup> ]	314	1257	2827	4301
<b>Europe</b>		<b>Coefficient of discharge K<sub>dr</sub></b>			
PED / DIN EN ISO 4126-1 12/2013	Approval No.	072020111Z0008/0/11			
	S/G	0.8	0.8	0.75	0.8
	L	0.6	0.54	0.5	0.56
<b>Germany</b>		<b>Coefficient of discharge α<sub>w</sub></b>			
PED / AD 2000-Merkblatt A2 07/2012	Approval No.	TÜV SV 934			
	S/G	0.8	0.8	0.75	0.8
	L	0.6	0.54	0.5	0.56
<b>United States</b>		<b>Coefficient of discharge K</b>			
ASME Sec. VIII	Approval No.	M37066	M37066	M37088	M37066
	S/G	0.798	0.798	0.754	0.798
	Approval No.	M37077	M37077	M37099	M37077
	L	0.572	0.572	0.479	0.572
<b>Canada</b>		<b>Coefficient of discharge K</b>			
CRN	Approval No.	-			
	S/G	0.798	0.798	0.754	0.798
	L	0.572	0.572	0.479	0.572
<b>China</b>		<b>Coefficient of discharge α<sub>w</sub></b>			
AQSIQ	Approval No.	For current approval no. see <a href="http://www.leser.com">www.leser.com</a>			
	S/G	0.8	0.8	0.75	0.8
	L	0.6	0.54	0.5	0.56
<b>Eurasian Custom Union</b>		<b>Coefficient of discharge α<sub>w</sub></b>			
EAC	Approval No.	For current approval no. see <a href="http://www.leser.com">www.leser.com</a>			
	S/G	0.8	0.8	0.75	0.8
	L	0.6	0.54	0.5	0.56
<b>Classification societies</b>		on request			

## Type 455, 456

### Available Options

#### Heating jacket

H29, H30: Couplings G  $\frac{3}{8}$ , G  $\frac{3}{4}$   
 H31, H32: Flanges DN 15, DN 25

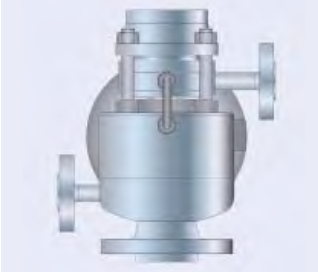

#### Drain hole

J18: G  $\frac{1}{4}$   
 J19: G  $\frac{1}{2}$

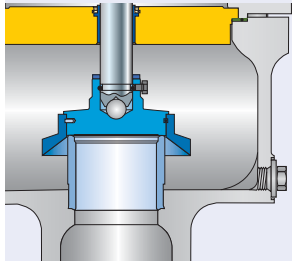

#### Open bonnet

See article number

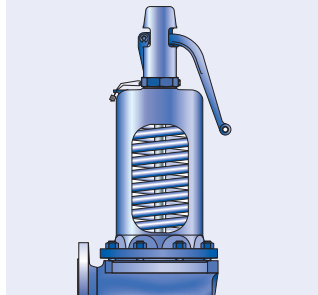

#### O-ring disc

J20: FFKM "C"  
 J21: CR "K"  
 J22: EPDM "D"  
 J23: FKM "L"

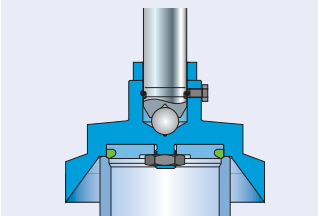

#### Stainless steel bellows

J68: Open bonnet  
 J78: Closed bonnet

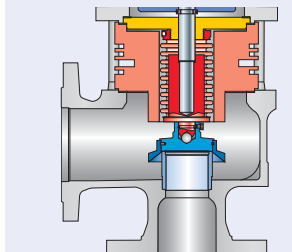

#### Conversion kit for stainless steel bellows on request

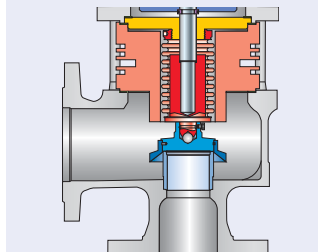

#### Screwed cap H2

H2



#### Plain lever H3

H3



#### Packed lever H4

H4

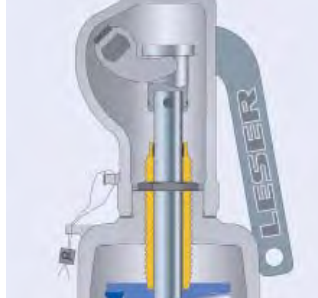

#### Test gag

J69: H4  
 J70: H2

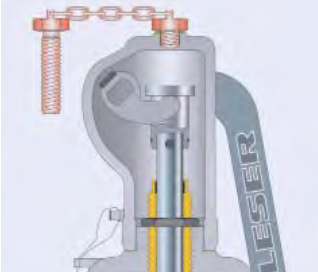

#### Lift indicator

J39: Adaptor H4  
 J93: Lift indicator

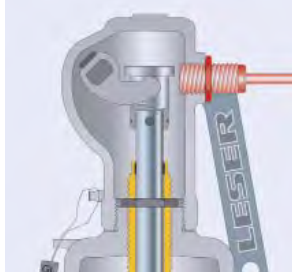

#### O-ring damper H2

J65

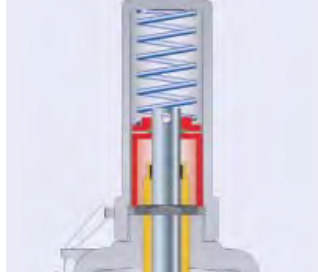

#### O-ring damper H4

J66





**Type 458**  
 Packed lever H4  
 Closed bonnet  
 Conventional design

**Type 457, 458**  
**Flanged Safety Relief Valves**

<b>Contents</b>	<b>Page</b>
<b>Materials</b>	
• Conventional design	88
• Balanced bellows design	90
<b>Article numbers</b>	92
<b>Dimensions and weights</b>	
• Metric Units	93
• US Units	94
<b>Pressure temperature ratings</b>	
• Metric Units	95
• US Units	96
Flange drillings	97
Flange facings	98
Approvals	99
Available options	100

**Type 457, 458**  
**Conventional design**

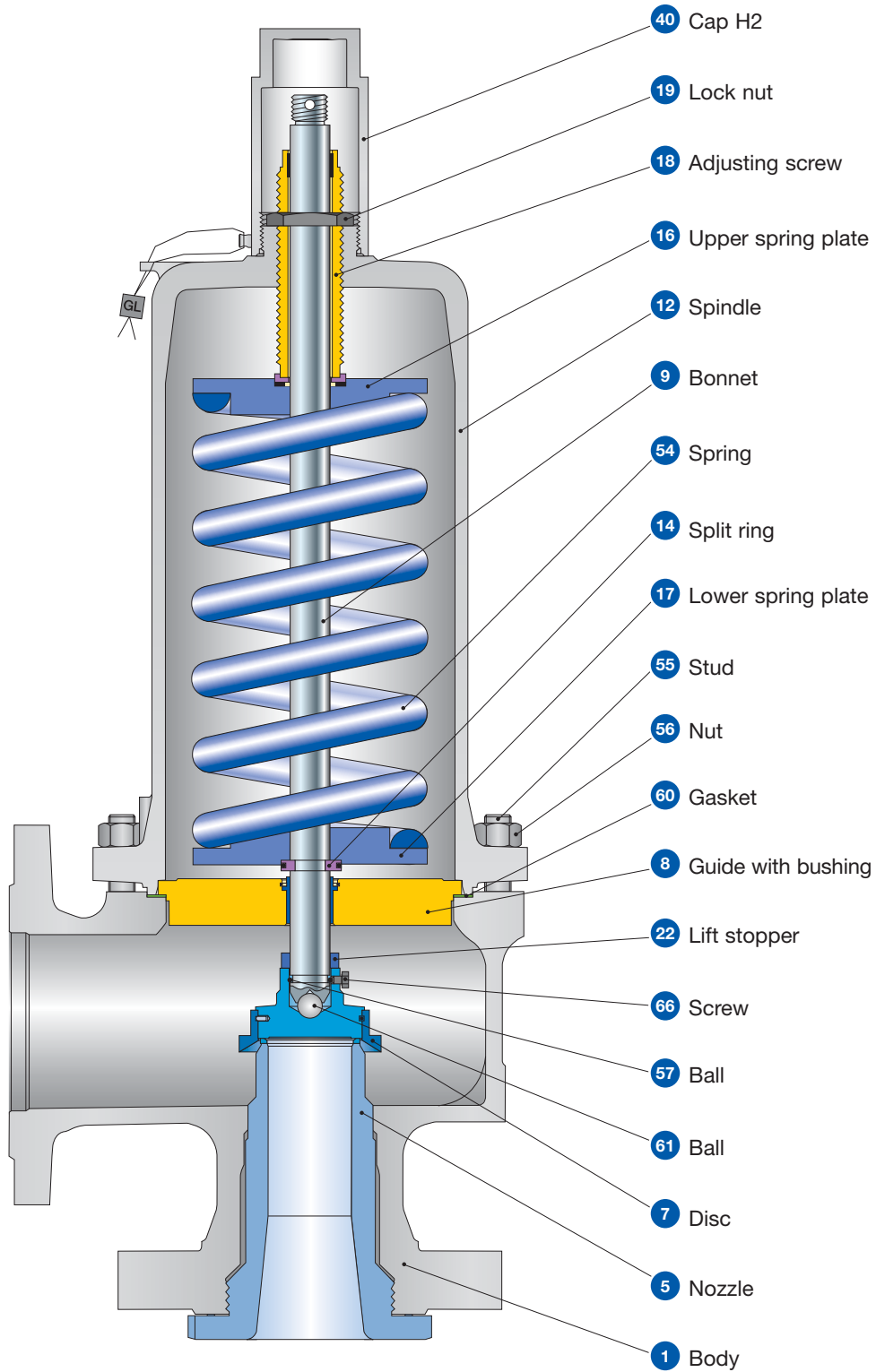

Type 457, 458



## Type 457, 458

### Conventional design

#### Materials

Item	Component	Type 4572 / 4582	Type 4577 / 4587	Type 4584
1	Body	1.0619	1.7357	1.4581
		SA 216 WCB	SA 217 WC6	SA 351 CF10M
5	Nozzle	1.4404 stellited	1.4404 stellited	1.4404 stellited
		316L stellited	316L stellited	316L stellited
7	Disc	1.4122	1.4122	1.4404
		Hardened stainless steel	Hardened stainless steel	316L
8	Guide with bushing	1.0501, 0.7040 Chrome or carbon steel	1.0501, 0.7040 Chrome or carbon steel	1.4404 316L
		1.4104 tenifer Chrome steel	1.4104 tenifer Chrome steel	–
9	Bonnet	0.7043 (Open bonnet 0.7040), 1.0619	0.7043 (Open bonnet 0.7040), 1.0619	1.4408, 1.4404, 1.4571
		Ductile Gr. 60-40-18, SA 216 WCB	Ductile Gr. 60-40-18, SA 216 WCB	SA 351 CF8M, SA 479 316L, 316Ti
12	Spindle	1.4404	1.4404	1.4404
		316L	316L	316L
14	Split ring	1.4104	1.4104	1.4404
		Chrome steel	Chrome steel	316L
16 / 17	Spring plate	1.0718	1.0718	1.4404
		Steel	Steel	316L
18	Adjusting screw with bushing	1.4104 PTFE	1.4104 PTFE	1.4404 PTFE
		Chrome steel PTFE	Chrome steel PTFE	316L PTFE
19	Lock nut	1.0718	1.0718	1.4404
		Steel	Steel	316L
22	Lift stopper	1.4404	1.4404	1.4404
		316L	316L	316L
40	Cap H2	1.0460	1.4404	1.4404
		SA 105	316L	316L
54	Spring standard	1.1200, 1.8159, 1.7102	1.1200, 1.8159, 1.7102	1.4310
		Carbon steel	Carbon steel	Stainless steel
	Spring optional	1.4310	1.4310	–
		Stainless steel	Stainless steel	–
55	Stud	1.4401	1.4401	1.4401
		B8M	B8M	B8M
56	Nut	1.4401	1.4401	1.4401
		8M	8M	8M
57	Ball	1.4401	1.4401	1.4401
		316	316	316
60	Gasket	Graphite / 1.4401	Graphite / 1.4401	Graphite / 1.4401
		Graphite / 316L	Graphite / 316L	Graphite / 316L
61	Ball	1.3541	1.3541	1.4401
		Hardened stainless steel	Hardened stainless steel	316
66	Screw	1.4401	1.4401	1.4401
		B8M	B8M	B8M

**Please notice:**

- Modifications reserved by LESER.
- LESER can upgrade materials without notice.
- Every part can be replaced by other material acc. to customer specification.

Type 457, 458  
Balanced bellows design

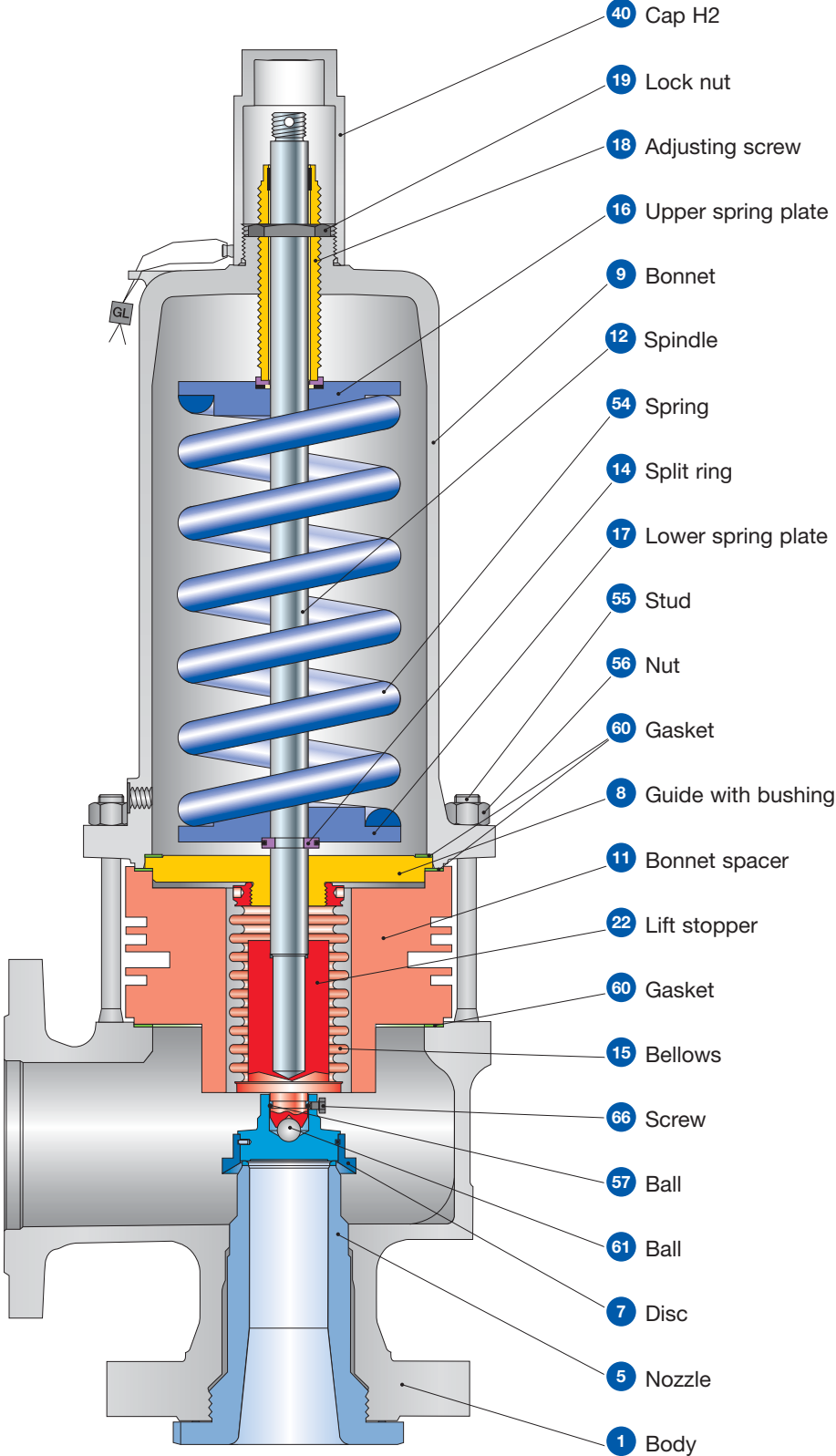

## Type 457, 458

### Balanced bellows design

#### Materials

Item	Component	Type 4572 / 4582	Type 4577 / 4587	Type 4584
1	Body	1.0619	1.7357	1.4581
		SA 216 WCB	SA 217 WC6	SA 351 CF10M
5	Nozzle	1.4404 stellited	1.4404 stellited	1.4404 stellited
		316L stellited	316L stellited	316L stellited
7	Disc	1.4122	1.4122	1.4404
		Hardened stainless steel	Hardened stainless steel	316L
8	Guide with bushing	1.0501, 0.7040	1.0501, 0.7040	1.4404
		Chrome or carbon steel	Chrome or carbon steel	316L
		1.4104 tenifer Chrome steel	1.4104 tenifer Chrome steel	-
9	Bonnet	0.7043 or 1.0619	0.7043 or 1.0619	1.4408, 1.4404, 1.4571
		Ductile Gr. 60-40-18 or SA 216 WCB	Ductile Gr. 60-40-18 or SA 216 WCB	SA 351 CF8M, SA 479 316L, 316Ti
11	Bonnet spacer	1.0460	1.0460	1.4404
		Carbon steel	Carbon steel	316L
12	Spindle	1.4404	1.4404	1.4404
		316L	316L	316L
14	Split ring	1.4104	1.4104	1.4404
		Chrome steel	Chrome steel	316L
15	Bellows	1.4571	1.4571	1.4571
		316Ti	316Ti	316Ti
16 / 17	Spring plate	1.0718	1.0718	1.4404
		Steel	Steel	316L
18	Adjusting screw with bushing	1.4104 PTFE	1.4104 PTFE	1.4404 PTFE
		Chrome steel PTFE	Chrome steel PTFE	316L PTFE
19	Lock nut	1.0718	1.0718	1.4404
		Steel	Steel	316L
22	Lift stopper	1.4404	1.4404	1.4404
		316L	316L	316L
40	Cap H2	1.0460	1.4404	1.4404
		SA 105	316L	316L
54	Spring standard	1.1200, 1.8159, 1.7102	1.1200, 1.8159, 1.7102	1.4310
		Carbon steel	Carbon steel	Stainless steel
	Spring optional	1.4310	1.4310	-
55	Stud	1.7709	1.7709	1.4401
		B16	B16	B8M
56	Nut	1.7258	1.7258	1.4401
		7M	7M	8M
57	Ball	1.4401	1.4401	1.4401
		316	316	316
60	Gasket	Graphite / 1.4401	Graphite / 1.4401	Graphite / 1.4401
		Graphite / 316L	Graphite / 316L	Graphite / 316L
61	Ball	1.3541	1.3541	1.4401
		Hardened stainless steel	Hardened stainless steel	316
66	Screw	1.4401	1.4401	1.4401
		B8M	B8M	B8M

#### Bitte beachten:

- LESER behält sich Änderungen vor.
- LESER kann, ohne vorherige Benachrichtigung, höherwertige Materials einsetzen.
- Jedes Bauteil kann entsprechend der Kundenspezifikation in einem anderen Werkstoff ausgeführt werden.

## Type 457, 458

### Article numbers

	DN <sub>I+O</sub>	25 x 50	25 x 50	50 x 80	50 x 80	80 x 100	80 x 100
	Valve size	1" x 2"	1" x 2"	2" x 3"	2" x 3"	3" x 4"	3" x 4"
	Actual Orifice diameter d <sub>0</sub> [mm]	15	20	30	40	50	60
	Actual Orifice area A <sub>0</sub> [mm <sup>2</sup> ]	177	314	707	1257	1964	2827

#### Body material: 1.0619 (WCB)

Bonnet closed	H2	Art. No. 4582.	6102	6112	6122	6132	6142	6152
	H3	Art. No. 4582.	6103	6113	6123	6133	6143	6153
	H4	Art. No. 4582.	6104	6114	6124	6134	6144	6154
open	H3	Art. No. 4572.	6105	6115	6125	6135	6145	6155

#### Body material: 1.7357 (WC6)

Bonnet closed	H2	Art. No. 4587.	6302	6312	6322	6332	6342	6352
	H3	Art. No. 4587.	6303	6313	6323	6333	6343	6353
	H4	Art. No. 4587.	6304	6314	6324	6334	6344	6354
open	H3	Art. No. 4577.	6305	6315	6325	6335	6345	6355

#### Body material: 1.4581 (CF10M)

Bonnet closed	H2	Art. No. 4584.	6202	6212	6222	6232	6242	6252
	H4	Art. No. 4584.	6204	6214	6224	6234	6244	6254

	DN <sub>I+O</sub>	100 x 150	100 x 150	100 x 150	100 x 150	150 x 250
	Valve size	4" x 6"	4" x 6"	4" x 6"	4" x 6"	6" x 10"
	Actual Orifice diameter d <sub>0</sub> [mm]	50	60	74	88	110
	Actual Orifice area A <sub>0</sub> [mm <sup>2</sup> ]	1964	2827	4301	6082	9503

#### Body material: 1.0619 (WCB)

Bonnet closed	H2	Art. No. 4582.	6162	6172	6182	6192	4602
	H3	Art. No. 4582.	-	-	-	-	-
	H4	Art. No. 4582.	6124	6174	6184	6194	4604
open	H3	Art. No. 4572.	6125	6175	6185	6195	4605

#### Body material: 1.7357 (WC6)

Bonnet closed	H2	Art. No. 4587.	6362	6372	6382	6392	-
	H3	Art. No. 4587.	-	-	-	-	-
	H4	Art. No. 4587.	6364	6374	6384	6394	-
open	H3	Art. No. 4577.	6365	6375	6385	6395	-

#### Body material: 1.4581 (CF10M)

Bonnet closed	H2	Art. No. 4584.	6262	6272	6282	6292	1.4408 (CF8M)	4732
	H4	Art. No. 4584.	6264	6274	6284	6294	4734	

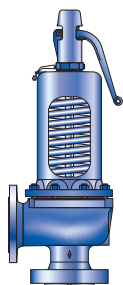

**Type 457**  
Plain lever H3  
Open bonnet  
Conventional design

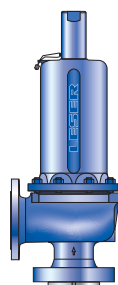

**Type 458**  
Cap H2  
Closed bonnet  
Conventional design

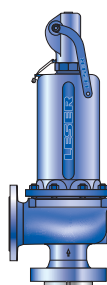

**Type 458**  
Packed lever H4  
Closed bonnet  
Conventional design

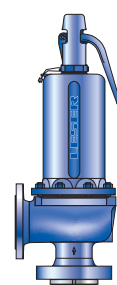

**Type 458**  
Plain lever H3  
Closed bonnet  
Conventional design

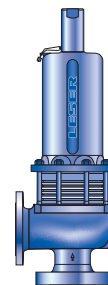

**Type 458**  
Cap H2  
Closed bonnet  
Balanced bellows design

## Type 457, 458

### Dimensions and weights

Metric Units

	DN <sub>ISO</sub>	25 x 50	25 x 50	50 x 80	50 x 80	80 x 100	80 x 100	100 x 150	100 x 150	100 x 150	100 x 150	150 x 250
Valve size		1" x 2"	1" x 2"	2" x 3"	2" x 3"	3" x 4"	3" x 4"	4" x 6"	4" x 6"	4" x 6"	4" x 6"	6" x 10"
Actual Orifice diameter d <sub>0</sub> [mm]		15	20	30	40	50	60	50	60	74	88	110
Actual Orifice area A <sub>0</sub> [mm <sup>2</sup> ]		177	314	707	1257	1964	2827	1964	2827	4301	6082	9503
<b>Weight</b> [kg]		20	20	45	45	88	88	157	157	157	157	131
	with bellows	22	22	48	48	108	108	188	188	188	188	162
<b>Center to face</b> <sup>1)</sup> [mm]	Inlet a	135	135	170	170	190	190	225	225	225	225	300
	Outlet b PN 40	120	120	145	145	180	180	235	235	235	235	225
	Outlet b PN 63	120	120	145	145	205	205	265	265	265	265	-
	Outlet b PN 160	130	130	-	-	-	-	-	-	-	-	-
<b>Measure</b> [mm]	PN 40 – 160	s	41	41	53	53	53	60	60	60	60	43
Used to find bolt length for inlet flange	PN 250	s	41	41	53	53	60	60	68	68	68	-
	PN 400	s	50	50	-	-	-	-	-	-	-	-
<b>Height (H4)</b> [mm]	Standard H max.	506	506	699	699	832	832	1079	1079	1079	1079	1098
	Bellows H max.	541	541	779	779	930	930	1170	1170	1170	1170	1156
<b>Support brackets</b> [mm]	A	140	140	184	184	278	278	364	364	364	364	320
	B	-	-	110	110	160	160	210	210	210	210	185
(drilled only on request, Option code H42)	C	Ø 14	Ø 14	Ø 14	Ø 14	Ø 18	Ø 18	Ø 18	Ø 18	Ø 18	Ø 18	Ø 18
	D	162	162	209	209	240	240	303	303	303	303	392
	E	18	18	18	18	27	27	32	32	32	32	28
<b>Body material: 1.0619 (WCB)</b>												
<b>DIN Flange</b> <sup>2)</sup>	Inlet	PN 63 – 250					PN 63 – 160					PN 40
	Outlet	PN 40 – 63					PN 40					PN 16
<b>Body material: 1.7357 (WC6)</b>												
<b>DIN Flange</b> <sup>2)</sup>	Inlet	PN 63 – 250					PN 63 – 160					-
	Outlet	PN 40 – 63					PN 40					-
<b>Body material: 1.4581 (CF10M)</b>												1.4408 (CF8M)
<b>DIN Flange</b> <sup>2)</sup>	Inlet	PN 63 – 250					PN 63 – 160					PN 40
	Outlet	PN 40 – 63					PN 40					PN 16

<sup>1)</sup> Please note: For design with welding flanges attention should be paid to differing center to face dimensions.

<sup>2)</sup> Standard flange rating. For other flange drillings please refer to page 97.

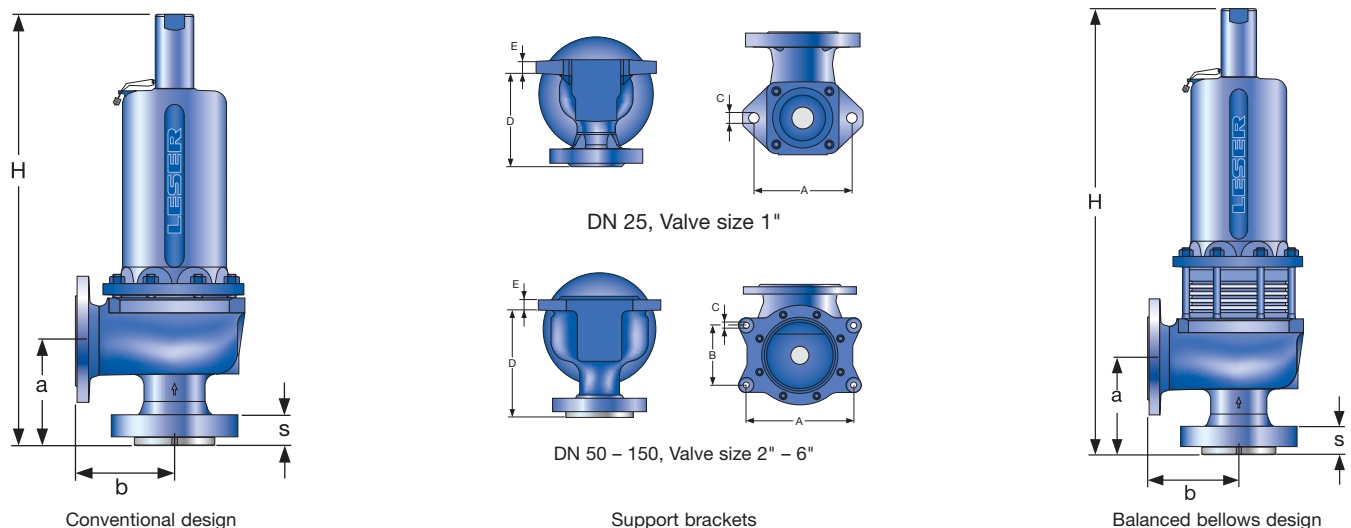

## Type 457, 458

### Dimensions and weights

#### US Units

	DN <sub>I+O</sub>	25 x 50	25 x 50	50 x 80	50 x 80	80 x 100	80 x 100	100 x 150	100 x 150	100 x 150	100 x 150	150 x 250
	Valve size	1" x 2"	1" x 2"	2" x 3"	2" x 3"	3" x 4"	3" x 4"	4" x 6"	4" x 6"	4" x 6"	4" x 6"	6" x 10"
	Actual Orifice diameter d <sub>0</sub> [inch]	0.59	0.79	1.18	1.57	1.97	2.36	1.97	2.36	2.91	3.46	4.33
	Actual Orifice area A <sub>0</sub> [inch <sup>2</sup> ]	0.274	0.487	1.096	1.948	3.043	4.383	3.043	4.383	6.666	9.427	14.730
<b>Weight</b> [lbs]		44	44	99	99	194	194	346	346	346	346	289
	with bellows	49	49	106	106	238	238	415	415	415	415	357
<b>Center to face<sup>1)</sup></b> [inch]	Inlet a	5 5/16	5 5/16	6 11/16	6 11/16	7 15/32	7 15/32	8 27/32	8 27/32	8 27/32	8 27/32	11 13/16
	Outlet b CL150	4 23/32	4 23/32	5 23/32	5 23/32	7 3/32	7 3/32	9 1/4	9 1/4	9 1/4	9 1/4	8 27/32
	Outlet b CL300	4 23/32	4 23/32	5 23/32	5 23/32	-	-	-	-	-	-	-
<b>Measure</b> [inch]	CL150	s	-	-	-	-	-	-	-	-	-	1 11/16
Used to find bolt length for inlet flange	CL300 – 600	s	1 5/8	1 5/8	2 1/16	2 1/16	2 1/16	2 3/8	2 3/8	2 3/8	2 3/8	-
	CL300 – 1500	s	1 5/8	1 5/8	2 1/16	2 1/16	-	-	-	-	-	-
<b>Height (H4)</b> [inch]	Standard H max.	19 29/32	19 29/32	27 17/32	27 17/32	32 3/4	32 3/4	42 1/2	42 1/2	42 1/2	42 1/2	43 7/32
	Bellows H max.	21 5/16	21 5/16	30 21/32	30 21/32	36 5/8	36 5/8	46 1/16	46 1/16	46 1/16	46 1/16	45 1/2
<b>Support brackets</b> [inch]	A	5 1/2	5 1/2	7 1/4	7 1/4	10 15/16	10 15/16	4 11/32	4 11/32	4 11/32	4 11/32	12 19/32
	B	-	-	4 11/32	4 11/32	6 5/16	6 5/16	8 9/32	8 9/32	8 9/32	8 9/32	7 9/32
(drilled only on request, Option code H42)	C	Ø 9/16	Ø 9/16	Ø 9/16	Ø 9/16	Ø 23/32	Ø 23/32	Ø 23/32	Ø 23/32	Ø 23/32	Ø 23/32	Ø 23/32
	D	6 3/8	6 3/8	8 7/32	8 7/32	9 7/16	9 7/16	11 11/32	11 11/32	11 11/32	11 11/32	15 7/16
	E	23/32	23/32	23/32	23/32	1 1/16	1 1/16	1 1/4	1 1/4	1 1/4	1 1/4	1 3/32
<b>Body material: 1.0619 (WCB)</b>												
<b>ANSI Flange</b>	Inlet	CL300 – 1500					CL300 – 600					CL150
<b>Class<sup>2)</sup></b>	Outlet	CL150 – 300					CL150					CL150
<b>Body material: 1.7357 (WC6)</b>												
<b>ANSI Flange</b>	Inlet	CL300 – 1500					CL300 – 600					-
<b>Class<sup>2)</sup></b>	Outlet	CL150 – 300					CL150					-
<b>Body material: 1.4581 (CF10M)</b>												<b>1.4408 (CF8M)</b>
<b>ANSI Flange</b>	Inlet	CL300 – 1500					CL300 – 600					CL150
<b>Class<sup>2)</sup></b>	Outlet	CL150 – 300					CL150					CL150

<sup>1)</sup> Please note: For design with welding flanges attention should be paid to differing center to face dimensions.

<sup>2)</sup> Standard flange rating. For other flange drillings please refer to page 97.

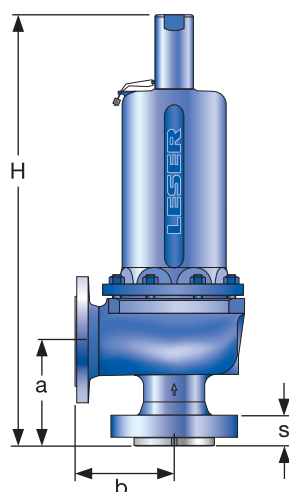

Conventional design

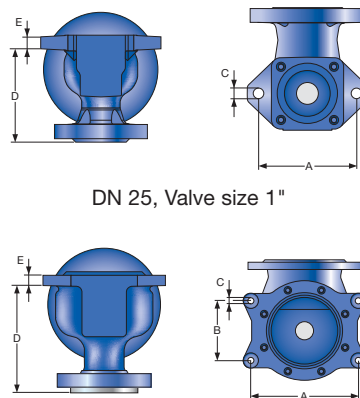

DN 25, Valve size 1"

DN 50 – 150, Valve size 2" – 6"

Support brackets

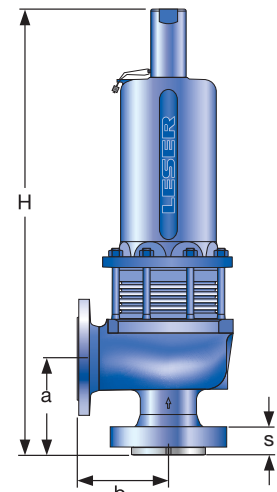

Balanced bellows design

## Type 457, 458

### Pressure temperature ratings

Metric Units

DN <sub>ISO</sub>	25 x 50	25 x 50	50 x 80	50 x 80	80 x 100	80 x 100	100 x 150	100 x 150	100 x 150	100 x 150	100 x 150	150 x 250
Valve size	1" x 2"	1" x 2"	2" x 3"	2" x 3"	3" x 4"	3" x 4"	4" x 6"	4" x 6"	4" x 6"	4" x 6"	4" x 6"	6" x 10"
Actual Orifice diameter d <sub>0</sub> [mm]	15	20	30	40	50	60	50	60	74	88	110	
Actual Orifice area A <sub>0</sub> [mm <sup>2</sup> ]	177	314	707	1257	1964	2827	1964	2827	4301	6082	9503	

#### Body material: 1.0619 (WCB)

DIN Flange		Inlet				Outlet				PN 40			
		PN 63 – 250				PN 40 – 63				PN 40			
<b>Minimum set pressure</b>	p [bar <sub>g</sub> ] S/G/L	2.5	2.5	2.5	2.5	2.5	2.5	2.5	2.5	2.5	2.5	2.5	2.5
<b>Min. set pressure<sup>1)</sup> standard bellows</b>	p [bar <sub>g</sub> ] S/G/L	13.5	13.5	20	2.5	10	10	10	6	5	5	5	5
<b>Min. set pressure low press. bellows</b>	p [bar <sub>g</sub> ] S/G/L					on request							
<b>Maximaler set pressure</b>	p [bar <sub>g</sub> ] S/G/L	300	180	125	98	130	77	43	46	53	34	18	
<b>Max. set pressure with special spring</b>	p [bar <sub>g</sub> ] S/G/L	300	180	210	114.5	160	77	160	160	77	53	40	
<b>Temperature</b>	min. [°C]	-85											
acc. to DIN EN	max. [°C]	+450											
<b>Temperature</b>	min. [°C]	-29											
acc. to ASME	max. [°C]	+427											

#### Body material: 1.7357 (WC6)

DIN Flange		Inlet				Outlet				PN 40			
		PN 63 – 250				PN 40 – 63				PN 40			
<b>Minimum set pressure</b>	p [bar <sub>g</sub> ] S/G/L	2.5	2.5	2.5	2.5	2.5	2.5	2.5	2.5	2.5	2.5	2.5	2.5
<b>Min. set pressure<sup>1)</sup> standard bellows</b>	p [bar <sub>g</sub> ] S/G/L	13.5	13.5	20	2.5	10	10	10	6	5	5	5	5
<b>Min. set pressure low press. bellows</b>	p [bar <sub>g</sub> ] S/G/L					on request							
<b>Maximaler set pressure</b>	p [bar <sub>g</sub> ] S/G/L	300	180	125	98	130	77	43	46	53	34	–	–
<b>Max. set pressure with special spring</b>	p [bar <sub>g</sub> ] S/G/L	300	180	210	114.5	160	77	160	160	77	53	–	–
<b>Temperature</b>	min. [°C]	-85											
acc. to DIN EN	max. [°C]	+550											
<b>Temperature</b>	min. [°C]	-29											
acc. to ASME	max. [°C]	+538											

#### Body material: 1.4581 (CF10M)

DIN Flange		Inlet				Outlet				PN 40			
		PN 63 – 250				PN 40 – 63				PN 40			
<b>Minimum set pressure</b>	p [bar <sub>g</sub> ] S/G/L	2.5	2.5	2.5	2.5	2.5	2.5	2.5	2.5	2.5	2.5	2.5	2.5
<b>Min. set pressure<sup>1)</sup> standard bellows</b>	p [bar <sub>g</sub> ] S/G/L	13.5	13.5	20	2.5	10	10	10	6	5	5	5	5
<b>Min. set pressure low press. bellows</b>	p [bar <sub>g</sub> ] S/G/L					on request							
<b>Maximaler set pressure</b>	p [bar <sub>g</sub> ] S/G/L	250	146	82	61	61	35	15.8	11	16.9	0	4.4	–
<b>Max. set pressure with special spring</b>	p [bar <sub>g</sub> ] S/G/L	250	146	130	65	104	51.5	71	55	49	32	10	–
<b>Temperature</b>	min. [°C]	-85											
acc. to DIN EN	max. [°C]	+550											
<b>Temperature</b>	min. [°C]	-29											
acc. to ASME	max. [°C]	+538											

<sup>1)</sup> Min. set pressure standard bellows = Max. set pressure low pressure bellows.

## Type 457, 458

### Pressure temperature ratings

#### US Units

DN <sub>r,0</sub>	25 x 50	25 x 50	50 x 80	50 x 80	80 x 100	80 x 100	100 x 150	100 x 150	100 x 150	100 x 150	100 x 150	150 x 250
Valve size	1" x 2"	1" x 2"	2" x 3"	2" x 3"	3" x 4"	3" x 4"	4" x 6"	4" x 6"	4" x 6"	4" x 6"	4" x 6"	6" x 10"
Actual Orifice diameter d <sub>0</sub> [inch]	15	20	30	40	50	60	50	60	74	88	110	
Actual Orifice area A <sub>0</sub> [inch <sup>2</sup> ]	177	314	707	1257	1964	2827	1964	2827	4301	6082	9503	

#### Body material: 1.0619 (WCB)

ANSI Flange Class <sup>1)</sup>	Inlet		CL300 – 1500				CL300 – 600				CL150		
	Outlet		CL150 – 300				CL150				CL150		
<b>Minimum set pressure</b>	p [psig]	S/G/L	36	36	36	36	36	36	36	36	36	36	
<b>Min. set pressure<sup>2)</sup> standard bellows</b>	p [psig]	S/G/L	196	196	290	36	145	145	145	87	73	73	
<b>Min. set pressure low press. bellows</b>	p [psig]	S/G/L					on request						
<b>Maximum set pressure</b>	p [psig]	S/G/L	4350	2610	1813	1421	1885	1117	624	667	769	493	
<b>Max. set pressure with special spring</b>	p [psig]	S/G/L	4350	2610	3045	1660	2320	1117	2320	2320	1117	769	
<b>Temperature acc. to DIN EN</b>	min. [°F]								-121				
	max. [°F]								+842				
<b>Temperature acc. to ASME</b>	min. [°F]								-20				
	max. [°F]								+800				

#### Body material: 1.7357 (WC6)

ANSI Flange Class <sup>1)</sup>	Inlet		CL300 – 1500				CL300 – 600				–		
	Outlet		CL150 – 300				CL150				–		
<b>Minimum set pressure</b>	p [psig]	S/G/L	36	36	36	36	36	36	36	36	36	36	
<b>Min. set pressure<sup>2)</sup> standard bellows</b>	p [psig]	S/G/L	196	196	290	36	145	145	145	87	73	73	
<b>Min. set pressure low press. bellows</b>	p [psig]	S/G/L					on request						
<b>Maximum set pressure</b>	p [psig]	S/G/L	4350	2610	1813	1421	1885	1117	624	667	769	493	
<b>Max. set pressure with special spring</b>	p [psig]	S/G/L	4350	2610	3045	1660	2320	1117	2320	2320	1117	769	
<b>Temperature acc. to DIN EN</b>	min. [°F]								-121				–
	max. [°F]								+1022				–
<b>Temperature acc. to ASME</b>	min. [°F]								-20				–
	max. [°F]								+1000				–

#### Body material: 1.4581 (CF10M)

ANSI Flange Class <sup>1)</sup>	Inlet		CL300 – 1500				CL300 – 600				1.4408 (CF8M)		
	Outlet		CL150 – 300				CL150				CL150		
<b>Minimum set pressure</b>	p [psig]	S/G/L	36	36	36	36	36	36	36	36	36	36	
<b>Min. set pressure<sup>2)</sup> standard bellows</b>	p [psig]	S/G/L	196	196	290	36	145	145	145	87	73	73	
<b>Min. set pressure low press. bellows</b>	p [psig]	S/G/L					on request				–		
<b>Maximum set pressure</b>	p [psig]	S/G/L	3625	2117	1189	885	885	508	229	160	245	0	
<b>Max. set pressure with special spring</b>	p [psig]	S/G/L	3625	2117	1885	943	1508	747	1030	798	711	464	
<b>Temperature acc. to DIN EN</b>	min. [°F]								-121				-454
	max. [°F]								+1022				+752
<b>Temperature acc. to ASME</b>	min. [°F]								-20				-450
	max. [°F]								+1000				+1000

<sup>1)</sup> For flange rating class 150 the pressure temperature ratings according to ASME ANSI B 16.34 apply.

<sup>2)</sup> Min. set pressure standard bellows = Max. set pressure low pressure bellows.



## Type 457, 458

### Flange drillings

	DN <sub>I/O</sub>	25 x 50	25 x 50	50 x 80	50 x 80	80 x 100	80 x 100	100 x 150	100 x 150	100 x 150	100 x 150	150 x 250		
	Valve size	1" x 2"	1" x 2"	2" x 3"	2" x 3"	3" x 4"	3" x 4"	4" x 6"	4" x 6"	4" x 6"	4" x 6"	6" x 10"		
	Actual Orifice diameter d <sub>0</sub> [mm]	15	20	30	40	50	60	50	60	74	88	110		
	Actual Orifice area A <sub>0</sub> [mm <sup>2</sup> ]	177	314	707	1257	1964	2827	1694	2827	4301	6082	9503		
<b>Body material: 1.0619 (WCB), 1.7357 (WC6), 1.4581 (CF10M), 1.4408 (CF8M)</b>														
<b>Inlet</b>	<b>DIN EN 1092</b>	PN 16	H47	H47	H47	H47	H47	H47	–	–	–	–	–	
		PN 25	H47	H47	H47	H47	H47	H47	H47	H47	H47	H47	*	
		PN 40	H47	H47	H47	H47	H47	H47	H47	H47	H47	H47	*	
		PN 63	*	*	H10	H10	H10	H10	H10	H10	H10	H10	S01	
		PN 100	*	*	*	*	*	*	*	*	*	*	–	
		PN 160	*	*	*	*	*	*	*	*	*	*	*	–
		PN 250	H12	H12	H12	H12	S01	S01	S01	S01	S01	S01	S01	–
		PN 320	S01	S01	S01	S01	S01	S01	S01	S01	S01	S01	S01	–
		PN 400	S01	S01	S01	S01	S01	S01	S01	S01	S01	S01	S01	–
	<b>ASME B16.5</b>	CL150	–	–	–	–	–	–	–	–	–	–	H64	
		CL300	H65	H65	H65	H65	H65	H65	H65	H65	H65	H65	–	
		CL600	H67	H67	H67	H67	H67	H67	H67	H67	H67	H67	–	
		CL900	H69	H69	H69	H69	S01	S01	S01	S01	S01	S01	–	
		CL1500	H69	H69	H69	H69	S01	S01	S01	S01	S01	S01	–	
		CL2500	S01	S01	S01	S01	S01	S01	S01	S01	S01	S01	–	
	<b>Outlet</b>	<b>DIN EN 1092</b>	PN 10	*	*	*	*	H51	H51	H51	H51	H51	H51	H50
			PN 16	*	*	*	*	H51	H51	H51	H51	H51	H51	*
			PN 25	*	*	*	*	*	*	*	*	*	*	–
PN 40			*	*	*	*	*	*	*	*	*	*	–	
PN 63			H16	H16	H16	H16	S01	S01	S01	S01	S01	S01	–	
<b>ASME B16.5</b>		CL150	H79	H79	H79	H79	H79	H79	H79	H79	H79	H79	H79	
		CL300	H80	H80	H80	H80	S01	S01	S01	S01	S01	S01	–	

## Type 457, 458

### Flange facings

Indication	Standard	Inlet		Outlet		Remark							
<b>General</b>													
Flange undrilled	–	H38		H39									
Linde-V-Nut, Type V48	Linde Standard 420-08 LDeS 3313.36	J07		J08		Groove: Rz 16							
Linde-V-Nut, Type V48A		J05		J06		Groove: Rz 4, e.g. with hydrogen							
Lens seal form L (without sealing lens)	DIN 2696 LDeS 3313.35	J11		J12									
<b>Acc. to DIN EN 1092</b>													
<b>Flange facing</b> (see LDeS 3313.40)		Inlet		Outlet		Remark							
		PN 10 – PN 40	PN 63 – PN 400	PN 10 – PN 40	PN 63	Rz-data according to DIN EN 1092 in µm							
Raised face	Type B1	*	–	*	–	Facing: Rz = 12.5 – 50							
	Type B2	–	*	L38	*	Facing: Rz = 3.2 – 12.5							
Tongue face C <sup>1)</sup>		–		H92		Steel flange only							
Groove face D <sup>1)</sup>		L55		H91									
Male face E		–		H98									
Female face F		–		H99									
O-ring male face G		–		J02									
O-ring female face H		–		J04									
<b>Acc. to ASME B16.5</b>													
Body material	Inlet	Outlet	Smooth finish <sup>2)</sup>		Serrated finish		RTJ-groove						
			Inlet	Outlet	Inlet	Outlet	Inlet					Outlet	
			Option code	Option code	CL300	CL600	CL900	CL1500	CL2500	CL150	CL300		
All	1"	2"	L52	L53	–	*	L58	L58	L58	L58	L58	H63	H63
	2"	3"	L52	L53	–	*	L58	L58	L58	L58	L58	H63	H63
	3"	4"	L52	L53	–	*	L58	L58	L58	L58	L58	–	H63
	4"	6"	L52	L53	–	*	L58	L58	L58	L58	–	–	H63

<sup>1)</sup> LESER manufactures the groove at flanged valves by milling. If a customer demands a turned surface in the soil of the groove according to DIN EN 1092-1 an additional option code is necessary: "S01: soil of the groove drilled". Groove and tongue for PN160 flanges refer to DIN 2512 / WI 3313.32.

<sup>2)</sup> Smooth finish is not defined in the effective standards.

Note: Flange drillings and facings meet always the requirements of mentioned flange standards.  
Flange thickness and outer diameter may vary from flange standard.

## Type 457, 458

### Approvals

	DN <sub>vo</sub>	25 x 50	25 x 50	50 x 80	50 x 80	80 x 100	80 x 100	100 x 150	100 x 150	100 x 150	100 x 150	100 x 250
	Valve size	1" x 2"	1" x 2"	2" x 3"	2" x 3"	3" x 4"	3" x 4"	4" x 6"	4" x 6"	4" x 6"	4" x 6"	6" x 10"
	Actual Orifice diameter d <sub>0</sub> [mm]	15	20	30	40	50	60	50	60	74	88	110
	Actual Orifice area A <sub>0</sub> [mm <sup>2</sup> ]	177	314	707	1257	1964	2827	1694	2827	4301	6082	9503
<b>Europe</b>												
<b>Coefficient of discharge K<sub>dr</sub></b>												
PED / DIN EN ISO 4126-1 12/2013	Approval No.	072020111Z0008/0/12										
	S/G	0.83	0.84	0.84	0.8	0.83	0.75	0.84	0.8	0.8	0.75	0.7
	L	0.63	0.6	0.58	0.54	0.58	0.5	0.6	0.54	0.56	0.49	0.45
<b>Germany</b>												
<b>Coefficient of discharge α<sub>w</sub></b>												
PED / AD 2000-Merkblatt A2 07/2012	Approval No.	TÜV SV 934										
	S/G	0.83	0.84	0.84	0.8	0.83	0.75	0.84	0.8	0.8	0.75	0.7
	L	0.63	0.6	0.58	0.54	0.58	0.5	0.6	0.54	0.56	0.49	0.45
<b>United States</b>												
<b>Coefficient of discharge K</b>												
ASME Sec. VIII	Approval No.	M37066	M37066	M37066	M37066	M37066	M37088	M37066	M37066	M37066	M37088	M37088
	S/G	0.798	0.798	0.798	0.798	0.798	0.754	0.798	0.798	0.798	0.754	0.754
	Approval No.	M37077	M37077	M37077	M37077	M37077	M37099	M37077	M37077	M37077	M37099	M37099
	L	0.572	0.572	0.572	0.572	0.572	0.479	0.572	0.572	0.572	0.479	0.479
<b>Canada</b>												
<b>Coefficient of discharge K</b>												
CRN	Approval No.	-										
	S/G	0.798	0.798	0.798	0.798	0.798	0.754	0.798	0.798	0.798	0.754	0.754
	L	0.572	0.572	0.572	0.572	0.572	0.479	0.572	0.572	0.572	0.479	0.479
<b>China</b>												
<b>Coefficient of discharge α<sub>w</sub></b>												
AQSIQ	Approval No.	For current approval no. see <a href="http://www.leser.com">www.leser.com</a>										
	S/G	0.83	0.84	0.84	0.8	0.83	0.75	0.84	0.8	0.8	0.75	0.7
	L	0.63	0.6	0.58	0.54	0.58	0.5	0.6	0.54	0.56	0.49	0.45
<b>Eurasian Custom Union</b>												
<b>Coefficient of discharge α<sub>w</sub></b>												
EAC	Approval No.	For current approval no. see <a href="http://www.leser.com">www.leser.com</a>										
	S/G	0.83	0.84	0.84	0.8	0.83	0.75	0.84	0.8	0.8	0.75	0.7
	L	0.63	0.6	0.58	0.54	0.58	0.5	0.6	0.54	0.56	0.49	0.45
<b>Classification societies</b>												
on request												

## Type 457, 458

### Available Options

#### Heating jacket

H29, H30: Couplings G  $\frac{3}{8}$ , G  $\frac{3}{4}$   
 H31, H32: Flanges DN 15, DN 25

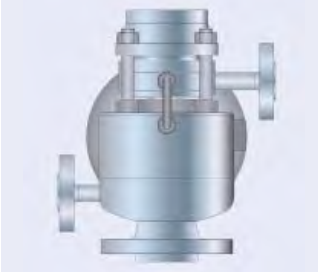

#### Drain hole

J18: G  $\frac{1}{4}$   
 J19: G  $\frac{1}{2}$

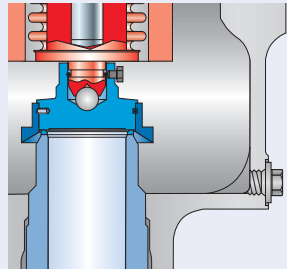

#### Open bonnet

See article number

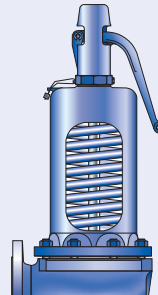

#### Butt-welded connection

S05

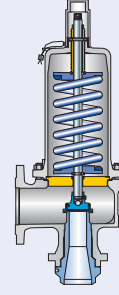

#### O-ring disc

J20: FFKM "C"  
 J21: CR "K"  
 J22: EPDM "D"  
 J23: FKM "L"

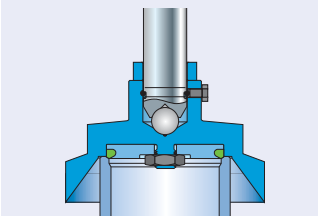

#### Stainless steel bellows

J68: Bonnet open  
 J78: Bonnet closed

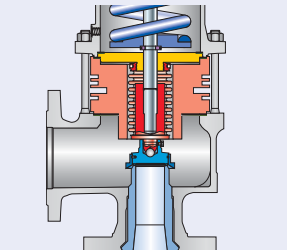

#### Conversion kit for stainless steel bellows

on request

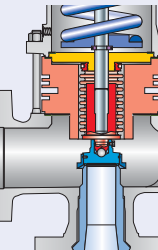

#### High temperature equipment

J88

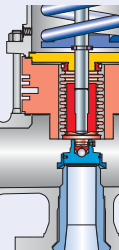

#### Screwed cap H2

H2



#### Plain lever H3

H3



#### Packed lever H4

H4

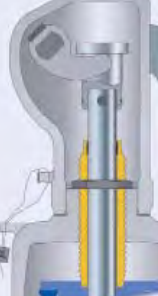

#### Test gag

J69: H4  
 J70: H2

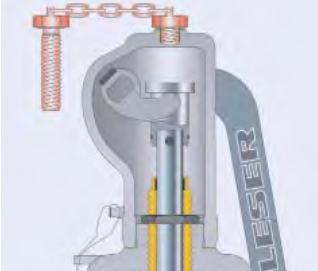

#### Lift indicator

J39: Adaptor H4  
 J93: Lift indicator

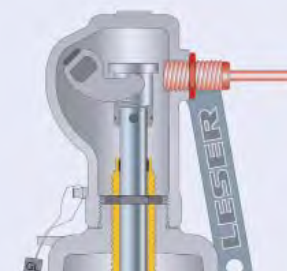

#### O-ring damper H2

J65

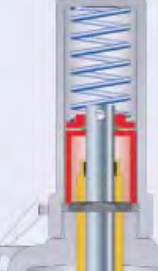

#### O-ring damper H4

J66

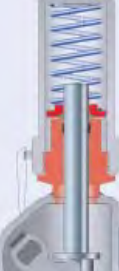



# LESER worldwide

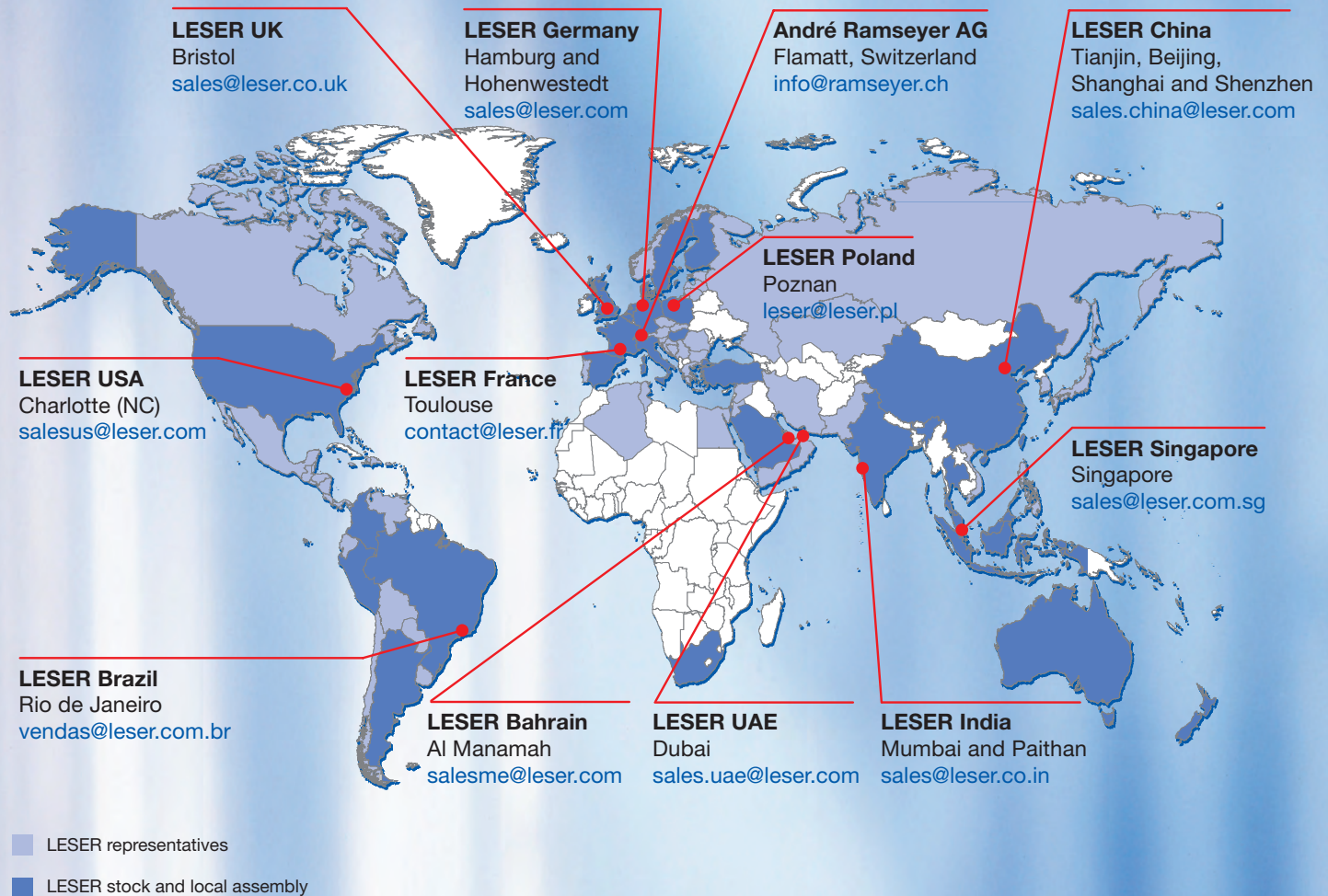

High Performance Catalog  
Edition July 2016 / 3.000  
0777.5465

# LESER

The-Safety-Valve.com

LESER GmbH & Co. KG

20537 Hamburg, Wendenstr. 133-135  
20506 Hamburg, P.O. Box 26 16 51

Fon +49 (40) 251 65-100  
Fax +49 (40) 251 65-500

E-Mail: [sales@leser.com](mailto:sales@leser.com)  
[www.leser.com](http://www.leser.com)