

Modulate Action

Safety Relief Valves

Series 433

Series 429



CATALOG

LESER

The-Safety-Valve.com

LESER Safety Valves for every industrial application



Modulate Action



**High
Performance**

Series 433

Type 431, 433



**Compact
Performance**

Type 431, 433 PN 160



API



**High
Efficiency**



**Clean
Service**

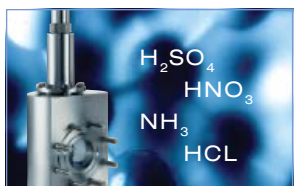

**Critical
Service**



**Best
Availability**

Series 429

Type 427, 429

General

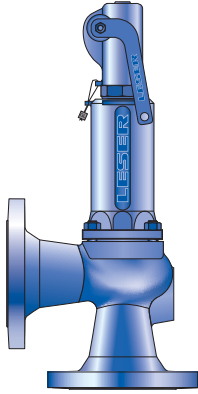

Type 431, 433

DN 15 – DN 150
Set pressure 0.2 – 40 bar

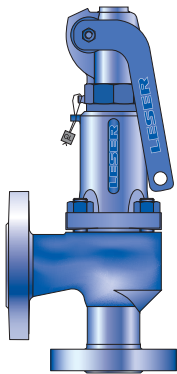

Type 431, 433 PN 160

DN 15
Set pressure 0.3 – 160 bar

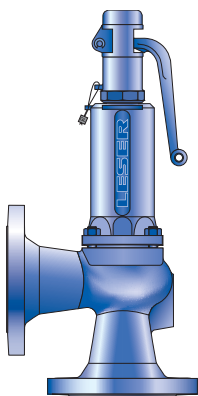

Type 427, 429

DN 15 – DN 150
Set pressure 1.5 – 40 bar

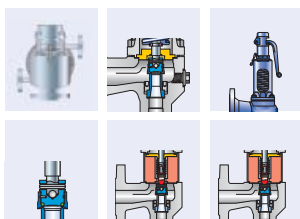

Options

Overview Chapter/Page

General	
General Information	00/01
Applications, General design features	00/02
Valve guide	00/03
Valve selection	00/05
How to use: Signs and symbols, Flange drillings and facings	00/07
How to use: Determination of coefficient of discharge K_{dr}/α_w	00/08
How to use: Capacity sheets	00/09
LESER Effective Orifice $LEO_{S/G}$	00/11
LESER Effective Orifice LEO_L	00/12
Sour gas service	00/13

LESER Type Chapter/Page

Type 431, 433		01/01
Materials		
• Conventional construction		01/02
• Balanced bellows construction		01/04
How to order:		
• Numbering system		01/06
• Article numbers		01/08
Pressure temperature ratings		
• Metric units		01/10
Dimensions and weights		
• Metric units		01/12
Approvals		01/13
Flange drillings		01/14
Flange facings		01/15
Order information - spare parts		01/16
Available options		01/18
Capacities		
• Steam	Metric units	01/19
• Air	Metric units	01/20
• Water	Metric units	01/21
Determination of coefficient of discharge K_{dr}/α_w		01/22

LESER Type Chapter/Page

Type 433 PN 160		02/01
Materials		
• Conventional design		02/02
• Balanced bellows design		02/04
How to order:		
• Numbering system		02/06
• Article numbers		02/08
Pressure temperature ratings		
• Metric units		02/09
Dimensions and weights		
• Metric units		02/10
Flange drillings and facings		02/11
Order information - spare parts		02/12
Available options		02/13
Approvals		02/14
Capacities		
• Steam, air, water	Metric units	02/15
Determination of coefficient of discharge K_{dr}/α_w		02/16

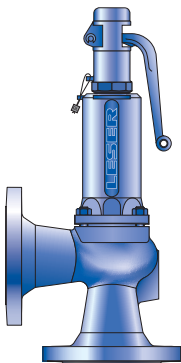

Type 433
Plain lever H3
Closed bonnet
Conventional design

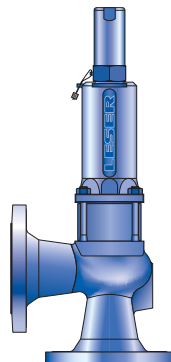

Type 433
Cap H2
Closed bonnet
Balanced bellows design

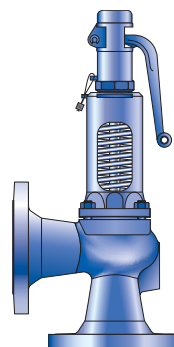

Type 431
Plain lever H3
Open bonnet
Conventional design

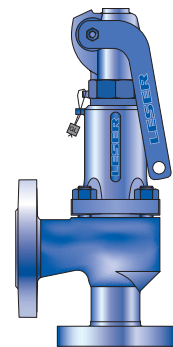

Type 433 PN 160
Packed lever H4
Closed bonnet
Conventional design

LESER Type	Chapter/Page	
Type 427, 429	03/01	
Materials		
• Conventional design	03/02	
• Balanced bellows design	03/04	
How to order:		
• Numbering system	03/06	
• Article numbers	03/08	
Pressure temperature ratings		
• Metric units	03/10	
Dimensions and weights		
• Metric units	03/12	
Flange drillings and facings	03/13	
Order information - spare parts	03/14	
Available options	03/16	
Approvals	03/17	
Capacities		
• Steam	Metric units	03/18
• Air	Metric units	03/19
• Water	Metric units	03/20

Options	Chapter/Page
Overview	99/02
Caps and lever	99/04
Metal seat	99/06
Soft seal disc	99/08
Soft seal	99/10
Disc	99/11
Balanced bellows	99/12
Heating jacket	99/14
O-ring damper	99/16
Elastomer bellows	99/18
Lift indicator	99/19
Lift restriction	99/20

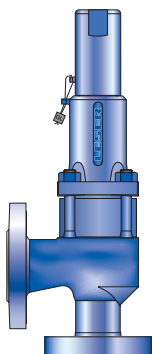

Type 433 PN 160
Cap H2
Closed bonnet
Balanced bellows design

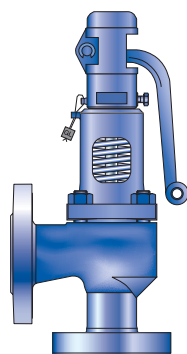

Type 431 PN 160
Plain lever H3
Open bonnet
Conventional design

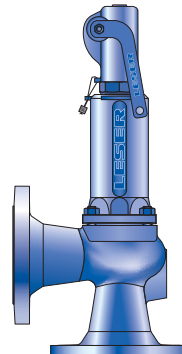

Type 429
Packed lever H4
Closed bonnet
Conventional design

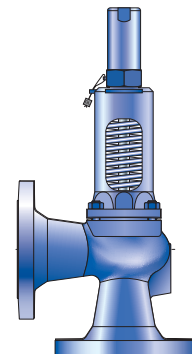

Type 427
Cap H2
Open bonnet
Conventional design



LESER – Modulate Action Safety Valves

The Modulate Action product group stands for

- ✓ Suitable solutions for all areas of applications, especially thermal expansion
- ✓ Lowest possible loss of medium
- ✓ Compact construction and low weight

LESER Modulate Action Safety Valves

- are characterised by longstanding proof in service and are constantly optimised by service specialists.
- are available as standard safety valves or proportional safety valves.
- reach their full lift within a pressure increase of 10% above the set pressure
- are suitable for almost all industrial applications.
- are accepted by numerous rules and regulations and approved by leading classification societies.

Examples of this are:

- **European Community:** CE marking as per Pressure Equipment Directives 97/23/EG and DIN EN ISO 4126-1
- **Germany:** VdTÜV approval as per Pressure Equipment Directive, EN ISO 4126-1, TÜV SV 100 and AD 2000-Merkblatt A2
- **China:** AQSIQ based on the approvals as per AD 2000-Merkblatt A2
- **Russia:** TR and RTN based on the AD 2000-Merkblatt A2 approval

Furthermore, all LESER Modulate Action safety valves are constructed, identified, produced, and approved in compliance with the following regulations:

EN ISO 4126-7, EN 12266-1/-2, EN 1092 Part I and II Flange, ASME B 16.34 and ASME B16.5- Flange, AD 2000-Merkblatt A4, AD 2000-Merkblatt HP0, TRD 110, TRD 421, TRD 721

LESER Modulate Action safety valves can be used for all steam, gas, and liquid applications and are characterised by their low loss of medium.

The Series 433 standard safety relief valves have component testing according to AD 2000-Merkblatt AT for steam, gases, and liquids. For the Series 429 proportional safety valves, there is only component testing as per AD 2000-Merkblatt A2 for steam and gasses, because the required coefficient of discharge is not reached for liquids. Nevertheless, Series 429 can be used as per the rules and regulations for thermal expansion.

Furthermore, Series 429 proportional safety valves are used as overflow valves or in bypass systems.



Applications

LESER – Modulate Action Safety Valves

provide the ultimate solution for all industrial applications with steam, gasses, and liquids.

Series 433 standard safety valves

acc. to definition AD 2000-Merkblatt A2

are ideal relief valves for medium mass flows. Their greater proportional range leads to a constant mode of operation and relief of pressure peaks for liquids in particular.

Typical applications for LESER Modulate Action Series 433 safety valves are:

- chemical industry
 - recycling facilities: Low medium loss
 - piping with long line lengths
 - two-phase flow
 - waste gas purification systems on the outlet side
- heat-transfer oil systems
- liquids protection
 - metering pumps
 - hydraulic systems
 - pulsating operating pressures
- machine building (OEM)
 - piston compressors with small and medium capacities
- overflow function
- thermal expansion
 - protection of pipeline segments
 - sealed storage tanks

Series 429 proportional safety valves

acc. to definition AD 2000-Merkblatt A2

opens proportional to pressure increase. This is usually achieved by using a disc without a lifting aid. Proportional safety valves are normally used anywhere where only very small mass flows are to be expected and the medium loss is to be kept as low as possible (e. g. thermal expansion).

Both proportional as well as standard safety valves are characterised by particularly stable operation.

General design feature

LESER – Modulate Action Safety Valves

offer a large number of models, materials, and accessories for adaptation to any application:

- 11 valve sizes from DN 15 to DN 150 – 1/2" up to 6" with connection possibilities for the respective application
- Nominal pressure ratings from PN 16 to PN 160 / Class 150 to Class 600 fulfil most pressure requirements
- Orifice $0.2 \times D$ to $> 1.1 \times M$ cover all common performance requirements.
- The required material for the application can be chosen from the large choice of body materials, for example:
 - 0.6025 / cast iron (Series 433)
 - 0.7043 / ductile iron
 - 1.0619 / WCB
 - 1.4408 / CF8M
- centre to face dimensions acc. to DIN 3320
- set pressures from 0.2 to 160 bar qualify Modulate Action safety valves for all industrial systems
- operating temperatures from -270 to 450 °C make use possible in numerous applications
- compact construction and low weight for easy handling
- same nominal inlet and outlet diameter
- identical construction for steam, gasses and liquids (single trim) reduces the number of required spare parts and facilitates cost-effective maintenance
- construction without a blow down ring guarantees easy service and prevents incorrect settings of the blow down ring
- the one-part spindle reduces friction, guarantees optimal guidance and reliable operation under all operating conditions
- the self-emptying angle type body prevents residue and reduces corrosion

LESER – Modulate Action safety valves can be individually adapted to the applications with a multitude of accessories. Examples are:

- discs with soft seal (O-ring) fulfil increased demands of functional tightness
- stellited or hardened metal seat surfaces of disc and seat reduce the wear and increase the service life
- balanced bellows for compensation of the back pressure and to protect the moving parts
- heating jacket for heating the safety valve when protecting cold stiff media
- each component can be constructed of an alternative material according to customer specifications

How to find the right Product Group

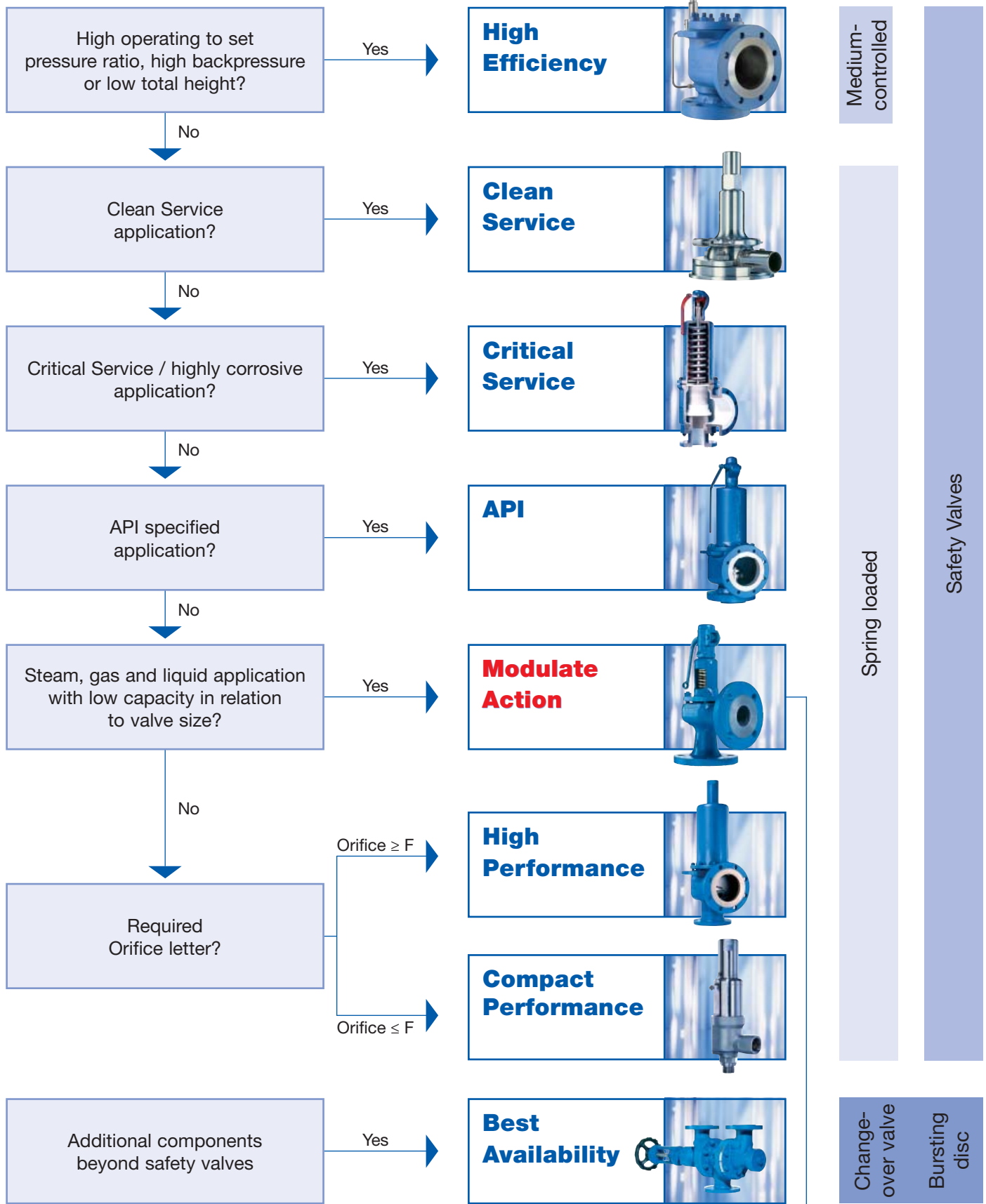

How to find the right Modulate Action Safety Valve

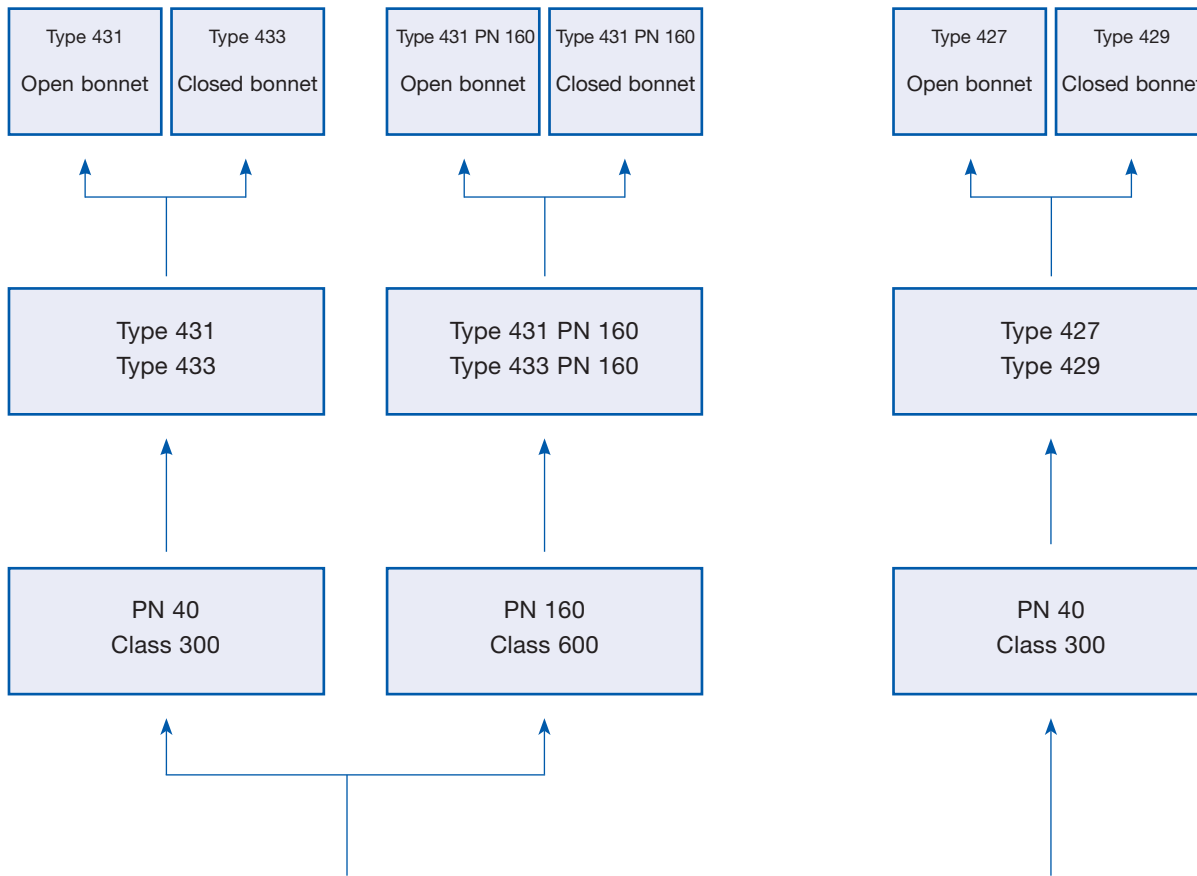

Standard Safety Valve
 acc. to definition AD 2000-Merkblatt A2
 for medium capacities with a large proportional range
 Mainly used for thermal expansion.

Proportional Safety Valve
 acc. to definition AD 2000-Merkblatt A2
 with linear opening and closing characteristics
 proportional to increasing or falling pressure
 Mainly used with incompressible media

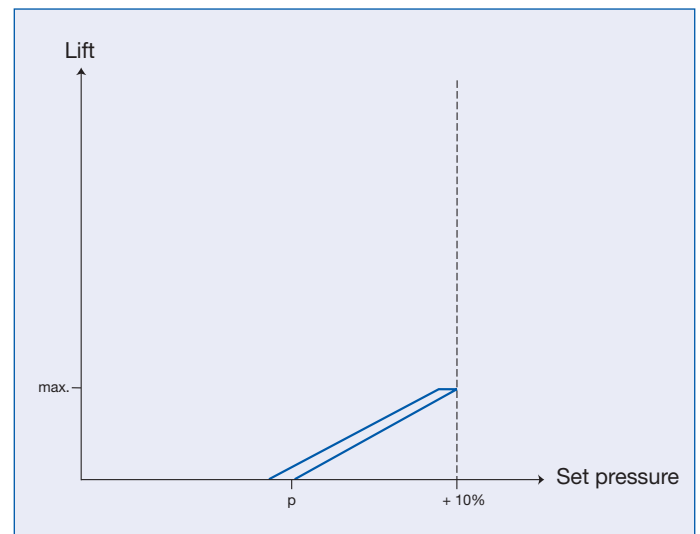
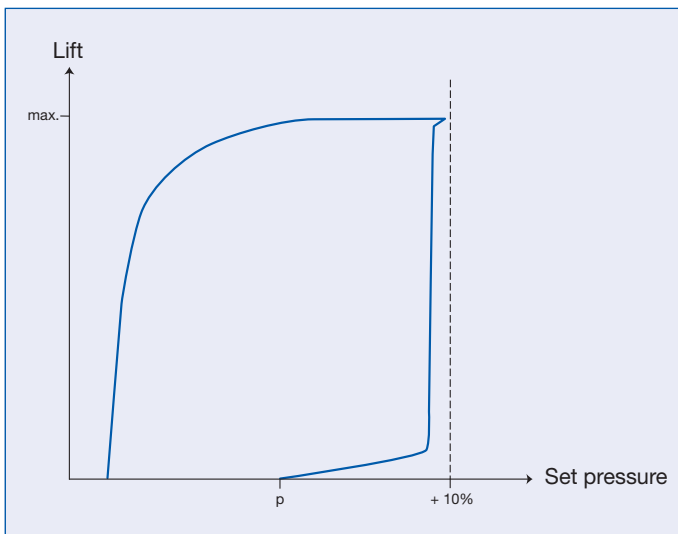

How to find the right Modulate Action Safety Valve

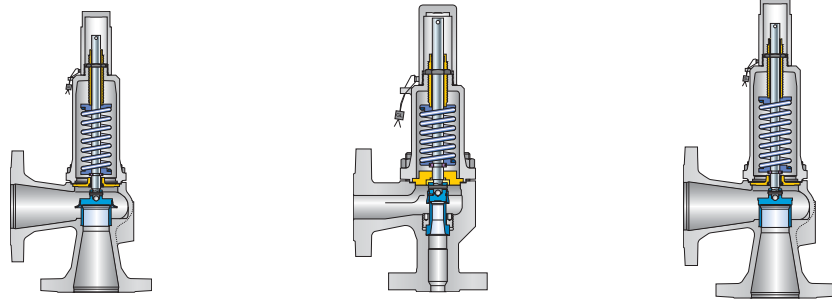

Valve size		431 / 433	433 PN 160	427 / 429
Type				
min.	DN 15			
	1/2"			
max.	DN 150			
	6"			

Materials		431 / 433	433 PN 160	427 / 429
Type				
0.6025	Cast iron	✓	-	-
0.7043	Ductile 60-40-18	✓	-	✓
1.0619	WCB	✓	✓	✓
1.4408	CF8M	✓	✓	✓

Set pressure		431 / 433	433 PN 160	427 / 429
Type				
Metric units min. [bar]		0.2	0.3	1.5
Metric units max. [bar]		40	160	40

Temperature application range		431 / 433	433 PN 160	427 / 429
Type				
According to DIN EN min. [°C]		-270	-270	-270
According to DIN EN max. [°C]		450	450	450

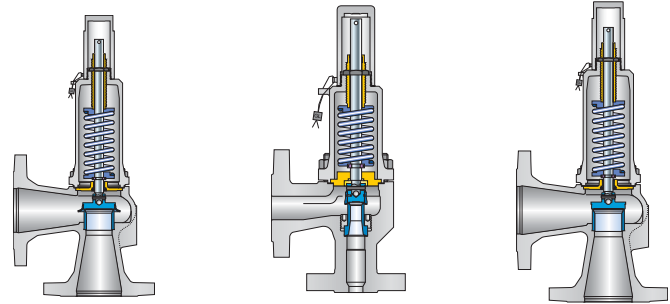

Capacity		Type	431 / 433	433 PN 160	427 / 429
Attention: Series 433 and 429 are CE certified, however not according to ASME.					
LEO _{S/G}	min.		0.111	0.111	0.023
LEO _{S/G}	max.		4.016	0.111	1.374
Orifice _{S/G}	min.		1.0 x D	1.0 x D	1.0 x D
Orifice _{S/G}	max.		1.1 x M	1.0 x D	1.07 x J
LEO _L	min.		0.115	0.129	The required discharge coefficient for liquids of α_w 0,05 acc. to AD 2000-Merkblatt A2 is not reached, therefore a component test is not possible.
LEO _L	max.		3.963	0.127	
Orifice _L	min.		1.0 x D	1.2 x D	
Orifice _L	max.		1.1 x M	1.2 x D	

Coefficient of discharge		Type	431 / 433				433 PN 160		427 / 429
			DN 15 O-ring disc	DN 15 Metal seat	DN 20	DN 25 - 150	DN 15 O-ring disc	DN 15 Metal seat	
Pressure increase acc. to DIN EN ISO 4126			10%	10%	10%	10%	10%	10%	10%
	K_{dr} / α_w S/G		0.59	0.62	0.29	0.38	0.59	0.62	0.13
	K_{dr} / α_w L		0.47	0.48	0.19	0.25	0.47	0.48	The required discharge coefficient for liquids of α_w 0,05 acc. to AD 2000-Merkblatt A2 is not reached, therefore a component test is not possible.

Approvals			Type	431 / 433	433 PN 160	427 / 429
Country	Code	Media			HDD	
Europe	DIN EN ISO 4126-1 CE marking	S/G/L		072020111Z0008/0/06	072020111Z0008/0/06	072020111Z0008/0/04
Germany	AD 2000- Merkblatt A2	S/G/L		TÜV SV 577	TÜV SV 577	TÜV SV 610
China	AQSIQ	S/G/L		✓	✓	-
Russia	TR / RTN	S/G/L		✓	✓	-
Kazakhstan	GOST-K	S/G/L		✓	✓	-
Belarus	GOSPROMNAZADOR	S/G/L		✓	✓	✓
Classification societies						
Bureau Veritas	BV			✓	✓	On request
ClassNK NIPPON Kaiji Kyokai	NK			✓	✓	
Det Norske Veritas	DNV			✓	✓	
Germanischer Lloyd	GL			✓	✓	
Lloyd's Register EMEA	LREMEA			✓	✓	
Registro Italiano Navale	RINA			✓	✓	

General signs and symbols		Signs and symbols for flange drillings and flange facings	
<input type="checkbox"/> *	Standard	<input type="checkbox"/> *	Standard construction, specification of an option code not necessary
<input type="checkbox"/> ✓	Available	<input type="checkbox"/> (*)	Flange dimensions with exception of flange thickness as per flange standards (e.g. ASME B16.5) Flange thickness is less (max. 2 mm), see "Hole patterns valid for different pressure ratings"
<input type="checkbox"/> -	Not possible	<input type="checkbox"/> -	Flange hole pattern / sealing surface not possible

Option code for flange drillings and dimensions, e.g. H50

H50	Flange drilling as specified in flange standard Outer flange diameter, flange thickness and height of flange facing may be larger, see "Dimensions"
(H50)	Flange dimensions except flange thickness are in accordance with standards (e.g. ASME B16.5) Flange thickness is smaller (max. 2 mm), see "Multiple pressure rating"
Stock Fini	Flange drilling as specified in standard. Flange thickness may be less than the flange outer diameter as specified in the standard, however complete nut support area is available

Option code for flange sealing surfaces, e.g. L36

L36	Flange facing as specified in standard (e.g. Flange facing inlet Type B2 "smooth finish")
------------	-------------------------------------------------------------------------------------------

General information concerning flange drillings and flange facings

Multiple pressure rating	The flange standard shows the same drilling, facing and outer diameter for several pressure ratings, e.g. from PN 16 to PN 40. Due to the pressure rating of the body, LESER fulfills the requirements for flange thickness, e.g. PN 16 but not PN 40.
Smooth Finish	In the applicable MSS SP-6 (Edition 2001), "Smooth Finish" is no longer mentioned. In MSS SP-6 (Edition 1980), "Smooth Finish" was defined as the surface quality of the flange with "250 µinch (6.3 µm) AARH max.". LESER supplies flange sealing surfaces according to ASME B16.5 – 1996, Paragraph 6.4.4.3: "Either a serrated concentric or serrated spiral finish resulting in service finish from 125 to 250 µinch average roughness shall be furnished" This finish meets the requirements of MSS SP-6 (Edition 1980), which is not valid anymore!
Stock Finish	"Stock Finish" is not defined in any technical standard. If "Stock Finish" is specified in the order, then LESER delivers standard flange sealing surfaces as per DIN or ASME (marked with * in the "Flange sealing surfaces" table for each series).

Pressures – Symbols in use

Symbols	Name	Metric units
p	Set pressure	bar
p ₀	Absolute pressure in vessel = p · 1.1 + 1.013 = p · 1.1 + 14.5 The overpressure is 10% of the set pressure, but at least 0.2 bar	bar _a
p _a	Back pressure	bar
p _{a0}	Absolute back pressure (= p _a + 1.013) (= p _a + 14.5)	bar _a

Materials

In the table below, you will find a list of the LESER material codes. Please take into consideration that

- material quality certificate 3.1 acc. to EN 10204 is available for each body material
- material quality certificate 3.1, which certifies different materials, is available for many materials.

Material code	Valve body with flanges	Body material is certified acc. to 3.1 (EN 10204) for the following materials	
		acc. to DIN EN	acc. to ASME
xxx1.xxxx	Grey iron	0.6025	Cast iron
xxx2.xxxx	Carbon steel	1.0619	WCB, WCC
xxx4.xxxx	Stainless steel	1.4408, 1.4581	CF8M (Charpy Test at -196°C), CF10M
xxx5.xxxx	Nodular cast iron	0.7043	Ductile Gr. 60-40-18
xxx7.xxxx	High temperature carbon steel	1.7357	WC6

Example of determination of K_{dr}/α_w : Type 433 DN 25

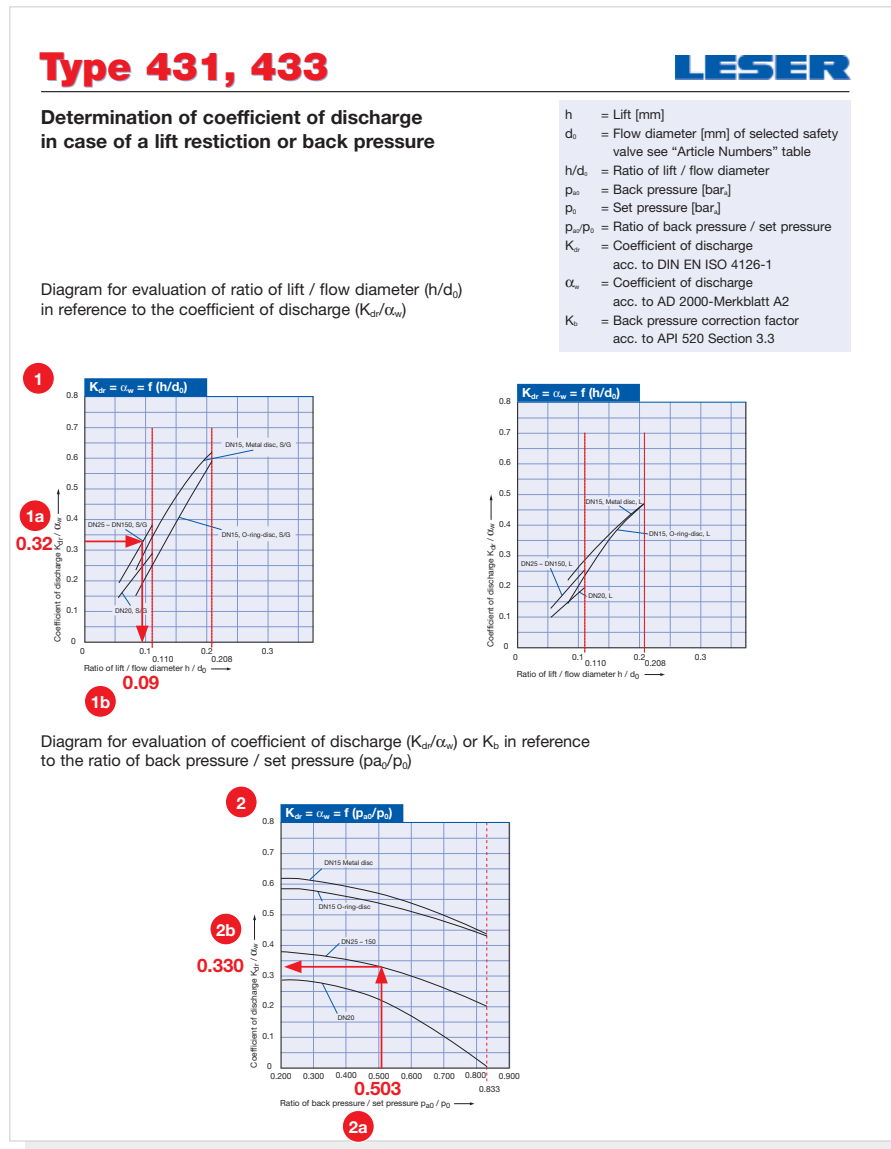

Explanation

Example – Type 433, flow diameter $d_0 = 13$ mm, Lift $h = 3.0$ mm, $K_{dr}/\alpha_w D/G = 0.81$

1 Diagram 1 Determining the restricted lift due to reduced K_{dr}/α_w			2 Diagram 2 Determination of reduced K_{dr}/α_w or K_b due to back pressure		
Step	Description	Example	Step	Description	Example
1	Calculation of the necessary coefficient of discharge for the selected safety valve. The applicable formulas are to be taken from the codes and standards.	1a $K_{dr}/\alpha_w = 0.32$	1	Calculation of the back pressure p_{ba}/p_0 with the use of the set pressure p_0 [bar _a] 0.962 and the back pressure p_{ba} [bar _a] 1.913	2a $p_{ba}/p_0 = 0.503$
2	Choose the starting point (0.3) on the Y-axis of the diagram		2	Choose the starting point (0.503) on the X-axis of the diagram	
3	Draw a horizontal line to determine the intersection point of the curves.		3	Draw a vertical line to determine the intersection point of the curves.	
4	Draw a vertical line through the intersection point on the X-axis to determine the ratio of lift / flow diameter (h/d_0).	1b $h/d_0 = 0.09$	4	Draw a horizontal line through the intersection point on the Y-axis to determine the reduced coefficient of discharge K_{dr}/α_w	2b $K_{dr}/\alpha_w = 0.330$
5	Calculation of the lift stopper with the formula $h = d_0 \times h/d_0$. (To order the lift restriction, please choose option code J51; see page 99/20).	$h = 13 \times 0.09$ $h = 1.17$ mm	5	Calculation of the valve with the established coefficient of discharge K_{dr}/α_w or the correction factor for back pressure K_b	

Sample capacity table – How to select capacities for steam: Type 433 DN 25

Capacity table – steam

Capacities for saturated steam according to AD 2000-Merkblatt A2, based on set pressure plus 10% overpressure.

Metric units		AD 2000-Merkblatt A2 [kg/h]													
	O-ring disc	Metal seat													
DN _i	15	15	20	25	32	40	50	65	80	100	125	150			
DN _o	15	15	20	25	32	40	50	65	80	100	125	150			
Actual Orifice diameter d ₀ [mm]	12	12	18	18	18	23	29	37	46	60	74	92			
Actual Orifice area A ₀ [mm ²]	113	113	254	254	254	416	661	1075	1662	2827	4301	6648			
LEO _{S/G} * [inch ²]	0.111	0.111	0.117	0.154	0.154	0.251	0.399	0.650	1.004	1.708	2.598	4.016			
Set pressure [bar]	Capacity [kg/h]														
0.2				34	34	55	88	142	220	375	570	880			
0.5	55	53	30	63	63	102	163	265	410	697	1060	1638			
1	78	78	67	101	101	165	263	428	661	1125	1711	2645			

Explanation		Type 433 DN 25		
No.	Name		Metric units	Example
1	Code			AD 2000-Merkblatt A2
2	Nominal inlet diameter	DN _i		25
3	Nominal outlet diameter	DN _o		25
4	Actual orifice diameter	d ₀	[mm]	18
5	Actual orifice area	A ₀	[mm ²]	254
6	LESER Effective Orifice	LEO _{S/G}	[inch ²]	0.154
7	Set pressure		[bar _g]	1
8	Capacity		[kg/h]	101
9	Calculation basis			See table on page 00/10

9

Calculation basis		Metric units	
Code		Capacity calculation according to AD 2000-Merkblatt A2	
Medium			
Steam (Saturated steam)	Standard conditions	Steam table IAPWS-IF97 IAPWS Industrial Formulation for the Thermodynamic Properties of water and steam	[kg/h]
Air	Standard conditions	0 °C and 1013 mbar	[m _n ³ /h]
Water	Standard conditions	20 °C	[10 ³ kg/h]
All media			
	Design pressure	Set pressure plus 10% overpressure	
	Design pressure for low set pressures	Capacity at 1 bar (14.5 psig) and lower are calculated at 0.1 bar (1.45 psig) overpressure.	

Example		Determining the design pressure	
Metric units			
Set pressure	Design pressure		
10 bar	10 bar + 10% overpressure = 11 bar		
0.5 bar	0.5 bar + 0.1 bar overpressure = 0.6 bar		

6

LESER Effective Orifice

Pressure relief devices may be initially sized using the equations shown in API RP 520, Section 3.6 to 3.10 for steam, gasses, liquids, or two-phase flow. These equations use the coefficient of discharge (S/G 0.975, L 0.650) and the effective area (acc. to API Std. 526, Fifth Edition, June 2002, table 1), which are independent of the valve design.

This way, the designer can determine a preliminary valve size. By using the LESER Effective Orifice (LEO), the designer can select the safety valve directly according to the calculation. A verification with the selected actual orifice area and the accorded coefficient of discharge is not necessary.

LEO_{S/G}	LESER Effective Orifice (for steam and gasses)	[inch²]	see page 00/11
LEO_L	LESER Effective Orifice (for liquids)	[inch²]	see page 00/12

For further information refer to LESER ENGINEERING at www.leser.com/engineering.

The table is based on the accorded coefficient of discharge for steam and gases for ASME certified LESER safety valves.
The associated K-values can be seen in the "K-values" column.

$$LEO_{S/G} [\text{inch}^2] = A_0 [\text{inch}^2] \cdot \left(\frac{K}{0.975} \right)$$

LEO _{S/G}		LESER Effective Orifice (for steam, gas and vapor)						
Orifice acc. to API 526	LESER series	DN	Inlet size	d ₀ [mm]	K _{dr} /α _w -values K-value ¹⁾	LEO _{S/G} [inch ²]	% of next higher orifice	% of next lower orifice
	429	15	1/2"	12.0	0.130	0.023	21.2%	
	429	20	3/4"	18.0	0.130	0.053	47.8%	
	429	25	1"	18.0	0.130	0.053	47.8%	
	429	32	1 1/2"	18.0	0.130	0.053	47.8%	
	429	40	1 1/2"	23.0	0.130	0.086	78.1%	
	433	15 O-ring disc	1/2"	12.0	0.590	0.106	96.4%	
D						0.110	100.0%	100.0%
	433	15 Metal seat	1/2"	12.0	0.620	0.111	56.9%	101.3%
	433	20	3/4"	18.0	0.290	0.117	56.9%	106.7%
	429	50	2"	29.0	0.130	0.137	69.6%	124.1%
	433	25	1"	18.0	0.380	0.154	78.4%	139.8%
	433	32	1 1/2"	18.0	0.380	0.154	78.4%	139.8%
E						0.196	100.0%	100.0%
	429	65	2 1/2"	37.0	0.130	0.222	72.4%	113.4%
	433	40	1 1/2"	23.0	0.380	0.251	81.8%	128.1%
F						0.307	100.0%	100.0%
	429	80	3"	46.0	0.130	0.343	68.3%	111.9%
	433	50	2"	29.0	0.380	0.399	79.3%	130.0%
G						0.503	100.0%	100.0%
	429	100	4"	60.0	0.130	0.584	74.4%	116.2%
	433	65	2 1/2"	37.0	0.380	0.650	82.7%	129.1%
H						0.785	100.0%	100.0%
	429	125	5"	74.0	0.130	0.889	69.1%	113.2%
	433	80	3"	46.0	0.380	1.004	78.0%	127.9%
J						1.287	100.0%	100.0%
	429	150	6"	92.0	0.130	1.374	74.7%	106.7%
	433	100	4"	60.0	0.380	1.708	92.9%	132.7%
K						1.838	100.0%	100.0%
	433	125	5"	74.0	0.380	2.598	91.1%	141.4%
L						2.853	100.0%	100.0%
M						3.600	100.0%	100.0%
	433	150	6"	92.0	0.380	4.016	92.5%	116.3%
N						4.340	100.0%	100.0%

¹⁾ There is no ASME approval for the LESER Modulate Action Series 433 and 429. In order to be able to still use the LEO and hence obtain compatibility to the orifice acc. to API 526, the K_{dr}/α_w-value (approval acc. to DIN EN ISO 4126-1 and AD 2000-Merkblatt A2) was brought into the calculation.

The table is based on the accorded coefficient of discharge for liquids for ASME certified LESER safety valves.
The associated K-values can be seen in the "K-values" column.

$$LEO_L [\text{inch}^2] = A_0 [\text{inch}^2] \cdot \left(\frac{K}{0.650} \right)$$

LEO _L		LESER Effective Orifice (for liquids)						
Orifice acc. to API 526	LESER series	DN	Inlet size	d ₀ [mm]	K _{dr} /α _w -values K-value ¹⁾	LEO _L [inch ²]	% of next higher orifice	% of next lower orifice
D						0.110	100.0%	100.0%
	433	20	3/4"	18.0	0.190	0.115	58.8%	104.8%
	433	15 O-ring disc	1/2"	12.0	0.590	0.127	64.8%	115.5%
	433	15 Metal seat	1/2"	12.0	0.480	0.129	66.0%	117.7%
	433	25	1"	18.0	0.250	0.152	77.4%	137.9%
	433	32	1 1/2"	18.0	0.250	0.152	77.4%	137.9%
E						0.196	100.0%	100.0%
	433	40	1 1/2"	23.0	0.250	0.248	80.7%	126.4%
F						0.307	100.0%	100.0%
	433	50	2"	29.0	0.250	0.394	78.3%	128.3%
G						0.503	100.0%	100.0%
	433	65	2 1/2"	37.0	0.250	0.641	81.7%	127.4%
H						0.785	100.0%	100.0%
	433	80	3"	46.0	0.250	0.991	77.0%	126.2%
J						1.287	100.0%	100.0%
	433	100	4"	60.0	0.250	1.686	91.7%	131.0%
K						1.838	100.0%	100.0%
	433	125	5"	74.0	0.250	2.564	89.9%	139.5%
L						2.853	100.0%	100.0%
M						3.600	100.0%	100.0%
	433	150	6"	92.0	0.250	3.963	91.3%	110.1%
N						4.340	100.0%	100.0%

¹⁾ There is no ASME approval for the LESER Modulate Action Series 433. In order to be able to still use the LEO and hence obtain compatibility to the orifice acc. to API 526, the K_{dr}/α_w-value (approval acc. to DIN EN ISO 4126-1 and AD 2000-Merkblatt A2) was brought into the calculation.

Normative basis

NACE MR0175-2003

In accordance with NACE standard MR0175-2003 sour gas service means the presence of H₂S in the following conditions:

Section 1.4.1.1 All gas, gas condensate, and sour crude oil – When the partial pressure of H₂S in a wet (water as a liquid) gas phase of a gas, gas condensate, or crude oil system is equal to or exceeds 0.003 bar_g (0.05 psia)

Exceptions are:

Section 1.4.2.1 Low-pressure gas

When the total pressure is lower than 4.5 bar_a (65 psia)

Section 1.4.2.2 Low-pressure oil and gas multiphase systems: ...

Other Sour gas standards:

NACE MR0103-2003: Materials resistance to sulfide stress cracking in corrosive petroleum refining environments.

DIN EN ISO 15156-1: Petroleum and natural gas industries – Materials for use in H₂S containing environments in oil and gas production – Part 1: General principles for selection of cracking-resistant materials (ISO 15156-1:2001)

Works standard: Please refer to LWN 001.91

General requirements for the use of sour gas

The standards given above require a maximum hardness of 22 HRC for most steels. The current requirements for a specific material are to be taken for the applied standards.

LESER sour gas level

General: The material requirements for the use of sour gas must be met if pressures and partial pressures are present according to the applied standards.

If an NACE construction is desired, then option code N78 must be selected.

The option codes for the individual components are given in the following table.

Based on this general statement, LESER defines two sour gas levels for safety valves:

Definition	Level 1		Level 2	
	Conventional	Balanced bellows	Conventional	Balanced bellows
Parts in contact with the medium with valve closed	Parts in contact with the medium with valve closed		Parts in contact with the medium with open, flowing valve	
Contact surfaces				
Pressure requirements	Set pressure ≥ 4.5 bar _a		Back pressure ≥ 4.5 bar _a	
Safety valve operation	closed		closed / open	
Affected components	Conventional design	Body / seat / disc	All	
	Balanced bellows design	Body / seat / disc	Body / seat / disc Bonnet spacer, Bellows	

Required material adjustment

Type	Body material	Design	Part	Material	Option code	Material	Option code
4292	1.0619 (WCB)	Conventional	Disc	1.4404 / 316L	L44	Please choose balanced bellows construction	
4332			Disc	1.4404 / 316L	L44	1.4404 / 316L	L44
4332 PN 160		Balanced bellows	Balanced bellows	1.4571 / 316Ti	J78	1.4571 / 316Ti	J78
4294	1.4408 (CF8M)	Conventional		No adjustment required		No adjustment required	
4334			Balanced bellows	Balanced bellows	1.4571 / 316Ti	J78	1.4571 / 316Ti
4334 PN 160							



Type 431
Plain lever H3
Open bonnet
Conventional design

Type 431, 433

Type 433

Flanged Safety Relief Valves - spring loaded



Type 433
Cap H2
Closed bonnet
Conventional design

Contents

Chapter/Page

Materials

- Conventional design 01/02
- Balanced bellows design 01/04

How to order

- Numbering system 01/06
- Article numbers 01/08

Pressure temperature ratings

- Metric units 01/10

Dimensions and weights

- Metric units 01/12

Approvals 01/13

Flange drillings 01/14

Flange facings 01/15

Order information – spare parts 01/16

Available options 01/18

Capacities

- Steam [Metric units] 01/19
- Air [Metric units] 01/20
- Water [Metric units] 01/21

Determination of coefficient of discharge K_{dr}/α_w 01/22

Conventional design

Type 433

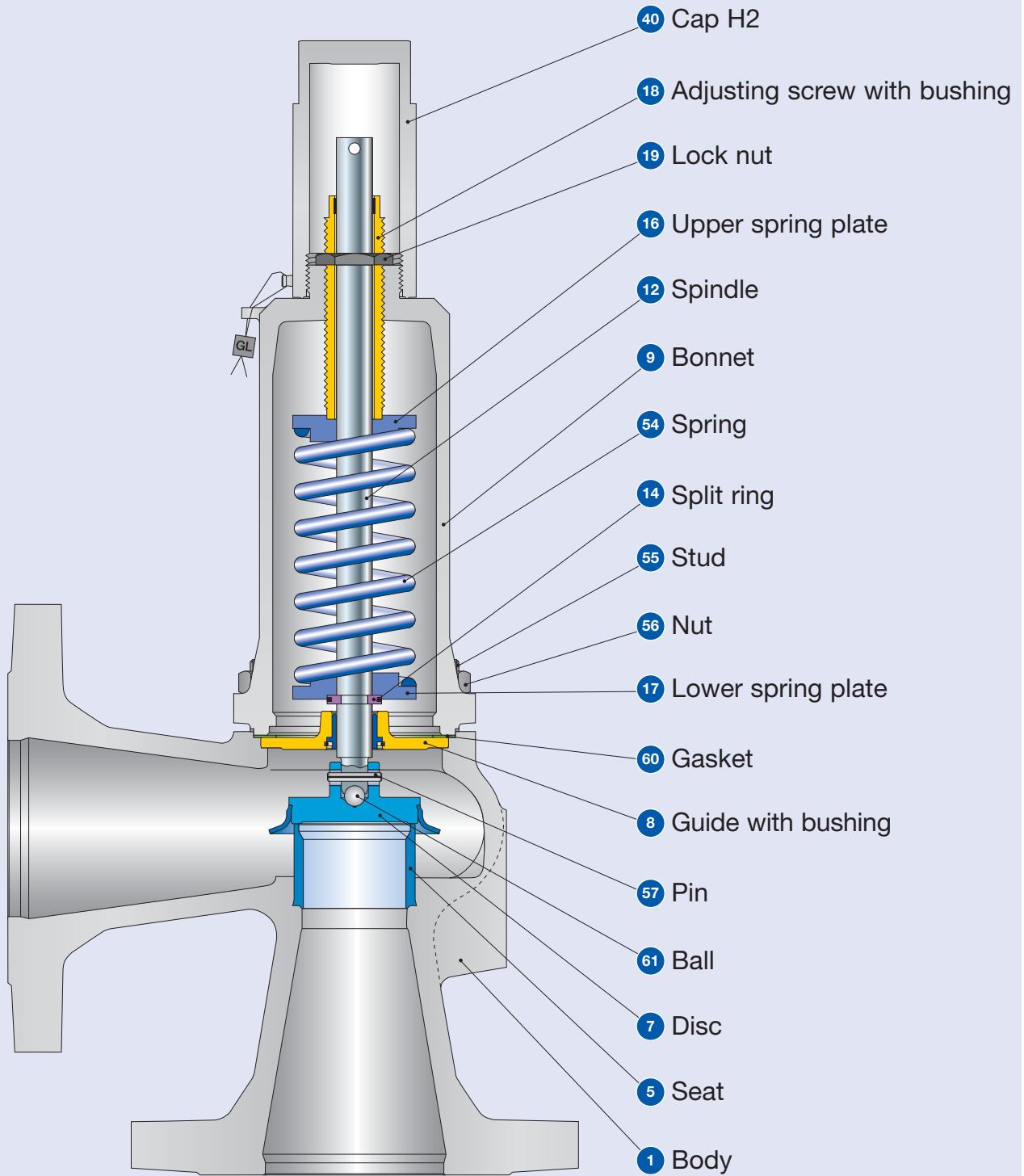

Conventional design

Materials		Type 4311 / 4331	Type 4315 / 4335	Type 4312 / 4332	Type 4334
1	Body	0.6025	0.7043	1.0619	1.4408
		Cast iron	Ductile Gr. 60-40-18	SA 216 WCB	SA 351 CF8M
5	Seat	1.4404	1.4404	1.4404	1.4404
		316L	316L	316L	316L
7	Disc	1.4122	1.4122	1.4122	1.4404
		Hardened stainless steel	Hardened stainless steel	Hardened stainless steel	316L
8	Guide	1.4104, 1.0501	1.4104, 1.0501	1.4104, 1.0501, 1.0570	1.4404
		Chrome or carbon steel	Chrome or carbon steel	Chrome or carbon steel	316L
	with bushing	1.4104 tenifer	1.4104 tenifer	1.4104 tenifer	–
		Chrome steel tenifer	Chrome steel tenifer	Chrome steel tenifer	–
9	Bonnet	0.7040	0.7040	0.7040	1.4408, 1.4404
		Ductile Gr. 60-40-18	Ductile Gr. 60-40-18	Ductile Gr. 60-40-18	SA 351 CF8M, SA 479 316L
12	Spindle	1.4021	1.4021	1.4021	1.4404
		420	420	420	316L
14	Split ring	1.4104	1.4104	1.4104	1.4404
		Chrome steel	Chrome steel	Chrome steel	316L
16/17	Spring plate	1.0718	1.0718	1.0718	1.4404
		Steel	Steel	Steel	316L
18	Adjusting screw with bushing	1.4104 PTFE	1.4104 PTFE	1.4104 PTFE	1.4404 PTFE
		Chrome steel PTFE	Chrome steel PTFE	Chrome steel PTFE	316L PTFE
19	Lock nut	1.0718	1.0718	1.0718	1.4404
		Steel	Steel	Steel	316L
40	Cap H2	1.0718	1.0718	1.0718	1.4404
		12L13	12L13	12L13	316L
54	Spring, standard	1.1200, 1.8159, 1.7102	1.1200, 1.8159, 1.7102	1.1200, 1.8159, 1.7102	1.4310
		Carbon steel	Carbon steel	Carbon steel	Stainless steel
	Spring, optional	1.4310	1.4310	1.4310	–
		Stainless steel	Stainless steel	Stainless steel	–
55	Stud	1.1181	1.1181	1.1181	1.4401
		Steel	Steel	Steel	B8M
56	Nut	1.0501	1.0501	1.0501	1.4401
		2H	2H	2H	8M
57	Pin	1.4310	1.4310	1.4310	1.4310
		Stainless steel	Stainless steel	Stainless steel	Stainless steel
60	Gasket	Graphite / 1.4401	Graphite / 1.4401	Graphite / 1.4401	Graphite / 1.4401
		Graphite / 316	Graphite / 316	Graphite / 316	Graphite / 316
61	Ball	1.3541	1.3541	1.3541	1.4401
		Hardened stainless steel	Hardened stainless steel	Hardened stainless steel	316

Please note:

- LESER reserves the right to make changes.
- If several materials are specified LESER defines the material.
- LESER may use higher quality materials without giving prior notice.
- Each component can be constructed of another material according to the customer's specification.
- All components exposed to pressure are highlighted in bold. The material will be specified according to DIN and ASTM here.

Type 431, 433

LESER

Balanced bellows design

Type 433

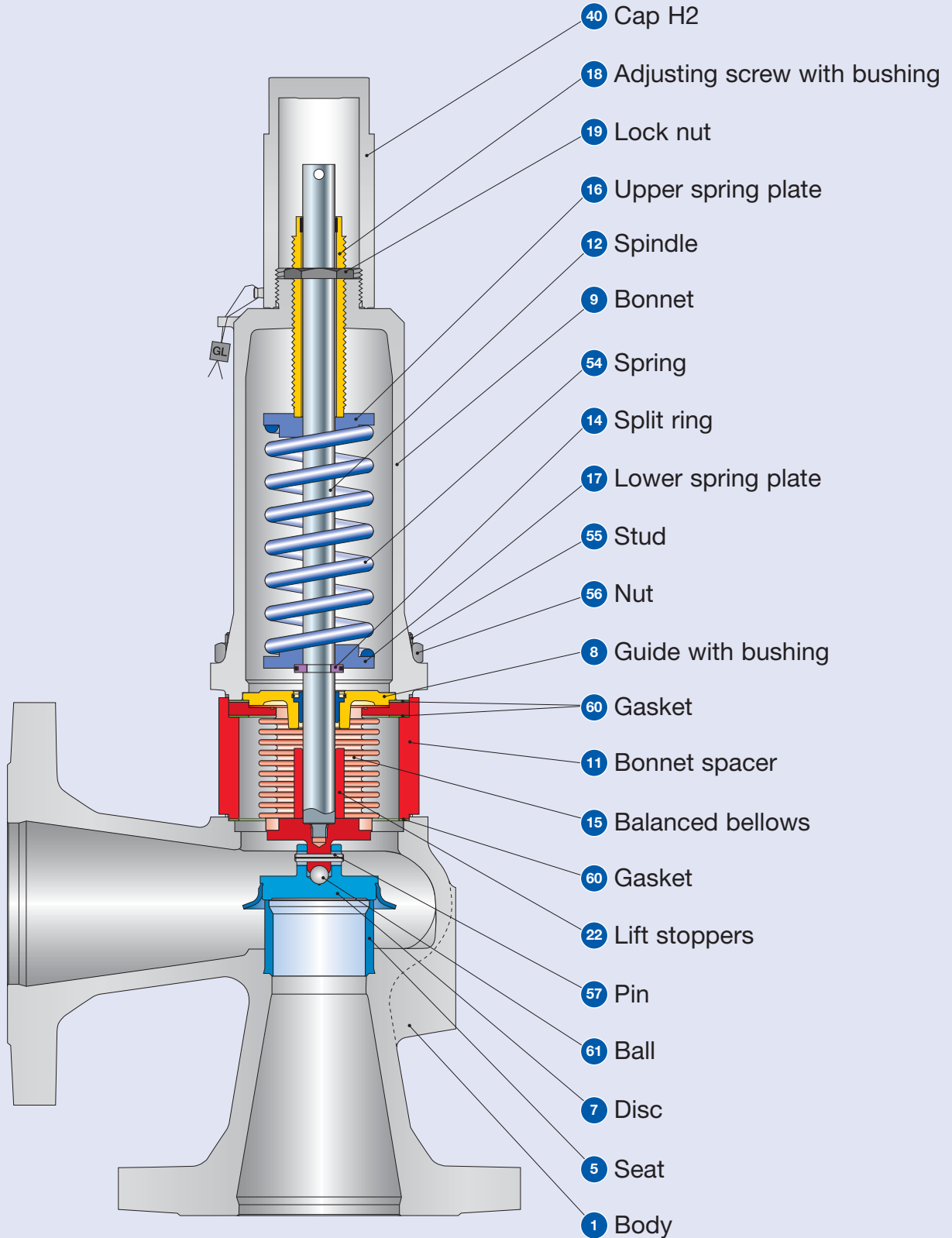

Balanced bellows design

Materials					
Item	Component	Type 4311 / 4331	Type 4315 / 4335	Type 4312 / 4332	Type 4334
1	Body	0.6025	0.7043	1.0619	1.4408
		Cast iron	Ductile Gr. 60-40-18	SA 216 WCB	SA 351 CF8M
5	Seat	1.4404	1.4404	1.4404	1.4404
		316L	316L	316L	316L
7	Disc	1.4122	1.4122	1.4122	1.4404
		Hardened stainless steel	Hardened stainless steel	Hardened stainless steel	316L
8	Guide	1.4104, 1.0501	1.4104, 1.0501	1.4104, 1.0501, 1.0570	1.4404
		Chrome or stainless steel	Chrome or stainless steel	Chrome or stainless steel	316L
	with bushing	1.4104 tenifer	1.4104 tenifer	1.4104 tenifer	-
		Chrome steel	Chrome steel	Chrome steel	-
9	Bonnet	0.7040	0.7040	0.7040	1.4408, 1.4404
		Ductile Gr. 60-40-18	Ductile Gr. 60-40-18	Ductile Gr. 60-40-18	SA 351 CF8M, SA 479 316L
11	Bonnet spacer	1.4404	1.4404	1.4404	1.4404
		316L	3316L	316L	316L
12	Spindle	1.4404	1.4404	1.4404	1.4404
		316L	316L	316L	316L
14	Split ring	1.4104	1.4104	1.4104	1.4404
		Chrome steel	Chrome steel	Chrome steel	316L
15	Balanced bellows	1.4571	1.4571	1.4571	1.4571
		316Ti	316Ti	316Ti	316Ti
16/17	Spring plate	1.0718	1.0718	1.0718	1.4404
		Steel	Steel	Steel	316L
18	Adjusting screw with bushing	1.4104 PTFE	1.4104 PTFE	1.4104 PTFE	1.4404 PTFE
		Chrome steel PTFE	Chrome steel PTFE	Chrome steel PTFE	316L PTFE
19	Lock nut	1.0718	1.0718	1.0718	1.4404
		Steel	Steel	Steel	316L
22	Lift stoppers	1.4404	1.4404	1.4404	1.4404
		316L	316L	316L	316L
40	Cap H2	1.0718	1.0718	1.0718	1.4404
		12L13	12L13	12L13	316L
54	Spring, standard	1.1200, 1.8159, 1.7102	1.1200, 1.8159, 1.7102	1.1200, 1.8159, 1.7102	1.4310
		Chrome steel	Chrome steel	Chrome steel	Stainless steel
	Spring, optional	1.4310	1.4310	1.4310	-
		Stainless steel	Stainless steel	Stainless steel	-
55	Stud	1.4401	1.4401	1.4401	1.4401
		B8M	B8M	B8M	B8M
56	Nut	1.4401	1.4401	1.4401	1.4401
		8M	8M	8M	8M
57	Pin	1.4310	1.4310	1.4310	1.4310
		Stainless steel	Stainless steel	Stainless steel	Stainless steel
60	Gasket	Graphite / 1.4401	Graphite / 1.4401	Graphite / 1.4401	Graphite / 1.4401
		Graphite / 316	Graphite / 316	Graphite / 316	Graphite / 316
61	Ball	1.3541	1.3541	1.3541	1.4401
		Hardened stainless steel	Hardened stainless steel	Hardened stainless steel	316

Please note:

- LESER reserves the right to make changes.
- If several materials are specified LESER defines the material.
- LESER may use higher quality materials without giving prior notice.
- Each component can be constructed of another material according to the customer's specification.
- All components exposed to pressure are highlighted in bold. The material will be specified according to DIN and ASTM here.

How to order – Example for numbering system – Type 433

Type 433

1

Article Number

4332.4192

2

Set Pressure

5 bar_g

3

Connections

H45

1	2	3	4
433	2	.419	2

1 Valve type 431, 433
 Type 433 – with closed bonnet
 Type 431 – with open bonnet

2 Material code

Code	Body material
1	0.6025 (cast iron)
2	1.0619 (WCB)
4	1.4408 (CF8M)
5	0.7043 (Ductile Gr. 60-40-18)

3 Valve code
 Automatically determines nominal diameter and body material (see page 01/09).

4

Code	Lifting device	
2	Gas-tight cap	H2
3	Plain lever	H3
4	Packed lever	H4
5	Plain lever with open bonnet	H3

Please enter the units (in gauge)!

The specified pressure range may not be exceeded!

See page 01/14.

4 Options

J22

Type 431, 433	Option code
• O-ring disc	
CR "K"	J21
EPDM "D"	J22
FKM "L"	J23
FFKM "C"	J20
• Disc 1.4404 / 316L	L44
• Disc 1.4404 / 316L stellited	J25
• Detachable lifting aid	J26
• Balanced bellows	
- Bonnet, open (Type 431)	J68
- Bonnet, closed (Type 433)	J78
• Elastomer bellows	J79
• High temperature alloy spring	X01
• Stainless steel spring	X04
• Adaptor for lift indicator H4	J39
• Lift indicator	J93
• Test gag	
- Cap H2	J70
- Packed lever H4	J69
• Heating jacket	
- Couplings G 3/8	H29
G 3/4	H30
- Flange DN 15	H31
DN 25	H32
• Drain hole G 1/4	J18
G 1/2	J19
• Oil and grease free	J85
• Materials	
- NACE	N78
Option code applies only if not standard	

5 Documentation

H01 L30

Please select the necessary documentation:

Tests, Certifications:	Option code
DIN EN 10204-3.2: TÜV-Nord Certification for set pressure	M33
LESER CGA (Certificate for Global Application)	H03
- Acceptance test certificate 3.1 acc. to DIN EN 10204	
- Declaration of conformity as per pressure equipment directive PED 97/23/EC	
Material quality certificate:	
DIN EN 10204-3.1	
Component	Option code
Body	H01
Bonnet	L30
Cap / lever cover	L31
Disc	L23
Screws	N07
Nuts	N08

6 Code and Medium

2.0

1	2
2	0
1 Code	
2. CE / VdTUEV	
3. ASME Section VIII + CE / VdTUEV	
2 Medium	
.0 steam / gases / liquids (only valid for CE / VdTUEV)	

Type 431, 433

LESER

How to order – Article numbers

Type 433

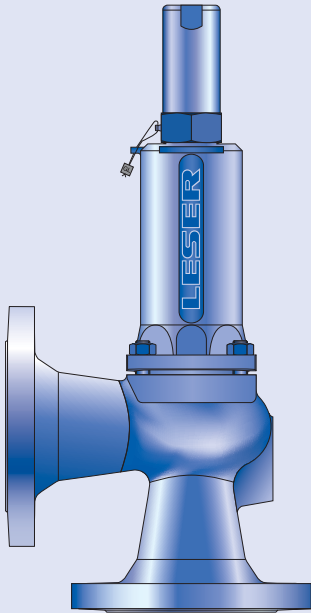

Type 433
Cap H2
Closed bonnet
Conventional design

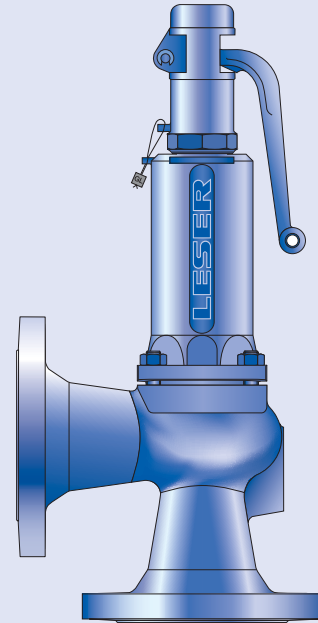

Type 433
Plain lever H3
Closed bonnet
Conventional design

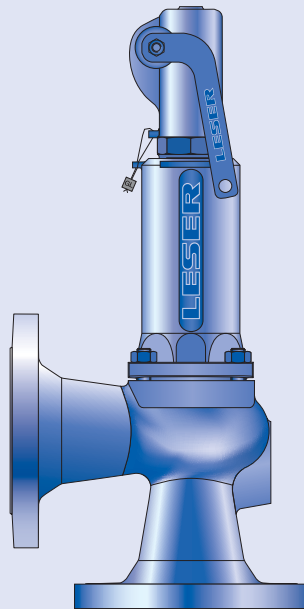

Type 433
Packed lever H4
Closed bonnet
Conventional design

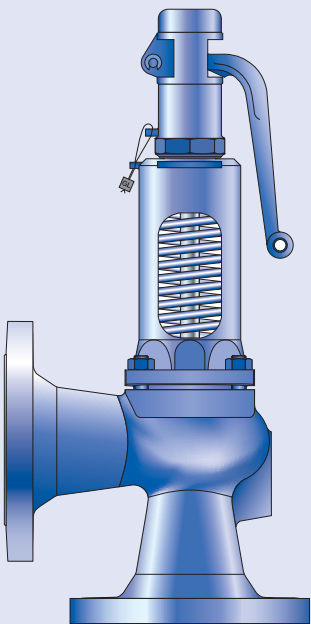

Type 431
Plain lever H3
Open bonnet
Conventional design

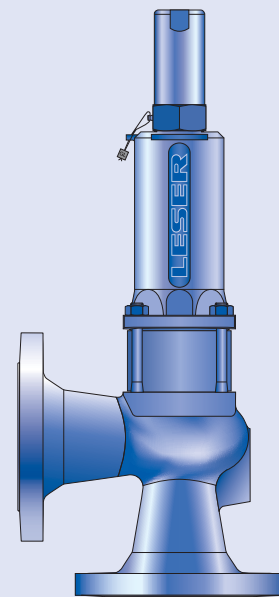

Type 433
Cap H2
Closed bonnet
Balanced bellows design

How to order – Article numbers

Article numbers														
		O-ring disc	Metal disc											
DN _i		15	15	20	25	32	40	50	65	80	100	125	150	
DN _o		15	15	20	25	32	40	50	65	80	100	125	150	
Actual orifice diameter d _o [mm]		12	12	18	18	18	23	29	37	46	60	74	92	
Actual orifice area A _o [mm ²]		113	113	254	254	254	416	661	1075	1662	2827	4301	6648	
Body material: 0.6025 (cast iron)														
Bonnet closed	H2	Art.-No. 4331.	8502	3992	4012	4022	4032	4042	4052	4062	4072	4082	-	-
	H3	Art.-No. 4331.	8503	3993	4013	4023	4033	4043	4053	4063	4073	4083	-	-
	H4	Art.-No. 4331.	8504	3994	4014	4024	4034	4044	4054	4064	4074	4084	-	-
open	H3	Art.-No. 4311.	8505	3995	4015	4025	4035	4045	4055	4065	4075	4085	-	-
Body material: 0.7043 (Ductile Gr. 60-40-18)														
Bonnet closed	H2	Art.-No. 4335.	8532	8752	8762	8772	8782	8792	8802	8812	8822	8832	-	-
	H3	Art.-No. 4335.	8533	8753	8763	8773	8783	8793	8803	8813	8823	8833	-	-
	H4	Art.-No. 4335.	8534	8754	8764	8774	8784	8794	8804	8814	8824	8834	-	-
open	H3	Art.-No. 4315.	8535	8755	8765	8775	8785	8795	8805	8815	8825	8835	-	-
Body material: 1.0619 (WCB)														
Bonnet closed	H2	Art.-No. 4332.	8512	4122	4142	4152	4162	4172	4182	4192	4202	4212	4222	4232
	H3	Art.-No. 4332.	8513	4123	4143	4153	4163	4173	4183	4193	4203	4213	4223	4233
	H4	Art.-No. 4332.	8514	4124	4144	4154	4164	4174	4184	4194	4204	4214	4224	4234
open	H3	Art.-No. 4312.	8515	4125	4145	4155	4165	4175	4185	4195	4205	4215	4225	4235
Body material: 1.4408 (CF8M)														
Bonnet closed	H2	Art.-No. 4334.	8522	4252	4272	4282	4292	4302	4312	4322	4332	4342	-	-
	H4	Art.-No. 4334.	8524	4254	4274	4284	4294	4304	4314	4324	4334	4344	-	-

Pressure temperature ratings

Metric units

	O-ring disc	Metal disc											
DN _i	15	15	20	25	32	40	50	65	80	100	125	150	
DN _o	15	15	20	25	32	40	50	65	80	100	125	150	
Actual orifice diameter d ₀ [mm]	12	12	18	18	18	23	29	37	46	60	74	92	
Actual orifice area A ₀ [mm ²]	113	113	254	254	254	416	661	1075	1662	2827	4301	6648	

Body material: 0.6025 (cast iron)

DIN flange	Inlet		PN 16										-	-		
	Outlet		PN 16													
Minimum set pressure	p [bar _g]	S/G/L	0.3	0.3	0.2	0.2	0.2	0.2	0.2	0.2	0.2	0.2	0.2	0.2	-	-
Min. set pressure¹⁾ standard bellows	p [bar _g]	S/G/L	3.0	3.0	3.0	3.0	3.0	3.0	3.0	3.0	3.0	3.0	3.0	3.0	-	-
Min. set pressure low pressure bellows	p [bar _g]	S/G/L	-	-	2.0	2.0	2.0	1.8	1.9	1.8	1.8	1.2	-	-	-	-
Maximum set pressure	p [bar _g]	S/G/L	16	16	16	16	16	16	16	16	16	16	16	16	-	-
Max. set pressure with special spring	p [bar _g]	S/G/L	16	16	16	16	16	16	16	16	16	16	16	16	-	-
Temperature²⁾ acc. to DIN EN	min. [°C]	-10											-10	-	-	
	max. [°C]	+150											+300	-	-	

Body material: 0.7043 (Ductile Gr. 60-40-18)

DIN flange	Inlet		PN 40										-	-		
	Outlet		PN 40													
Minimum set pressure	p [bar _g]	S/G/L	0.3	0.3	0.2	0.2	0.2	0.2	0.2	0.2	0.2	0.2	0.2	0.2	-	-
Min. set pressure¹⁾ standard bellows	p [bar _g]	S/G/L	3.0	3.0	3.0	3.0	3.0	3.0	3.0	3.0	3.0	3.0	3.0	3.0	-	-
Min. set pressure low pressure bellows	p [bar _g]	S/G/L	-	-	2.0	2.0	2.0	1.8	1.9	1.8	1.8	1.2	-	-	-	-
Maximum set pressure	p [bar _g]	S/G/L	16	16	16	16	16	16	16	16	16	16	16	16	-	-
Max. set pressure with special spring	p [bar _g]	S/G/L	16	16	16	16	16	16	16	16	16	16	16	16	-	-
Temperature²⁾ acc. to DIN EN	min. [°C]	-45											-60	-	-	
	max. [°C]	+150											+350	-	-	

¹⁾ Min. set pressure of standard bellows = max. set pressure of bellows for low set pressure.

²⁾ The temperature is limited by the soft seal material (see page 99/10). The values given here are valid for EPDM. Between -10°C and the lowest specified application temperature, proceed acc. to AD 2000-Merkblatt W10.

Pressure temperature ratings

Metric units															
		O-ring disc	Metal disc												
	DN _i	15	15	20	25	32	40	50	65	80	100	125	150		
	DN _o	15	15	20	25	32	40	50	65	80	100	125	150		
	Actual orifice diameter d ₀ [mm]	12	12	18	18	18	23	29	37	46	60	74	92		
	Actual orifice area A ₀ [mm ²]	113	113	254	254	254	416	661	1075	1662	2827	4301	6648		
Body material: 1.0619 (WCB)															
DIN flange		Inlet	PN 40												
		Outlet	PN 40												
Minimum set pressure	p [bar _g] S/G/L	0.3	0.3	0.2	0.2	0.2	0.2	0.2	0.2	0.2	0.2	0.2	0.2		
Min. set pressure¹⁾ standard bellows	p [bar _g] S/G/L	3.0	3.0	3.0	3.0	3.0	3.0	3.0	3.0	3.0	3.0	3.0	3.0		
Min. set pressure low pressure bellows	p [bar _g] S/G/L	–	–	2.0	2.0	2.0	1.8	1.9	1.8	1.8	1.2	1.2	on request		
Maximum set pressure	p [bar _g] S/G/L	40	40	40	40	40	40	40	35	35	30	32	16		
Max. set pressure with special spring	p [bar _g] S/G/L	40	40	40	40	40	40	40	40	35	30	32	16		
Temperature²⁾ acc. to DIN EN	min. [°C]	-45						-85						–	–
	max. [°C]	+150						+450						–	–
Body material: 1.4408 (CF8M)															
DIN flange		Inlet	PN 40											–	–
		Outlet	PN 40											–	–
Minimum set pressure	p [bar _g] S/G/L	0.3	0.3	0.2	0.2	0.2	0.2	0.2	0.2	0.2	0.2	0.2	–	–	
Min. set pressure¹⁾ standard bellows	p [bar _g] S/G/L	3.0	3.0	3.0	3.0	3.0	3.0	3.0	3.0	3.0	3.0	3.0	–	–	
Min. set pressure low pressure bellows	p [bar _g] S/G/L	–	–	2.0	2.0	2.0	1.8	1.9	1.8	1.8	1.2	–	–		
Maximum set pressure	p [bar _g] S/G/L	40	40	40	40	40	40	31.6	20.2	25	22	–	–		
Max. set pressure with special spring	p [bar _g] S/G/L	40	40	40	40	40	40	40	26	25	22	–	–		
Temperature²⁾ acc. to DIN EN	min. [°C]	-45						-270						–	–
	max. [°C]	+150						+400						–	–

¹⁾ Min. set pressure of standard bellows = max. set pressure of bellows for low set pressure.

²⁾ The temperature is limited by the soft seal material (see page 99/10). The values given here are valid for EPDM. Between -10°C and the lowest specified application temperature, proceed acc. to AD 2000-Merkblatt W10.

Dimensions and weights

Metric units

	O-ring disc	Metal disc										
DN _i	15	15	20	25	32	40	50	65	80	100	125	150
DN _o	15	15	20	25	32	40	50	65	80	100	125	150
Actual orifice diameter d ₀ [mm]	12	12	18	18	18	23	29	37	46	60	74	92
Actual orifice area A ₀ [mm ²]	113	113	254	254	254	416	661	1075	1662	2827	4301	6648
Weight [kg]	5	5	6	6	8	9	12	15	20	33	48	65
with bellows	6.3	6.3	6.4	6.4	8.4	9.6	13	16	21.6	35.6	52.1	78.4
Centre to face [mm]												
Inlet a	90	90	95	100	105	115	125	145	155	175	200	225
Outlet b	90	90	95	100	105	115	125	145	155	175	200	225
Height (H4) [mm]												
Standard H max.	310	310	315	320	325	335	360	475	530	605	745	870
Bellows H max.	362	362	345	350	360	390	425	535	600	680	825	965
Support brackets [mm]												
A												277
B												160
(Drilled only on request, option code H42)												Ø 18
C												278
D												21

Body material: 0.6025 (cast iron)

DIN flange¹⁾	Inlet	PN 16	-	-
	Outlet	PN 16	-	-

Body material: 0.7043 (Ductile Gr. 60-40-18)

DIN flange¹⁾	Inlet	PN 40	-	-
	Outlet	PN 40	-	-

Body material: 1.0619 (WCB)

DIN flange¹⁾	Inlet	PN 40	-	-
	Outlet	PN 40	-	-

Body material: 1.4408 (CF8M)

DIN flange¹⁾	Inlet	PN 40	-	-
	Outlet	PN 40	-	-

¹⁾ Standard flange class For other flange drillings, refer to page 01/14 and 01/15.

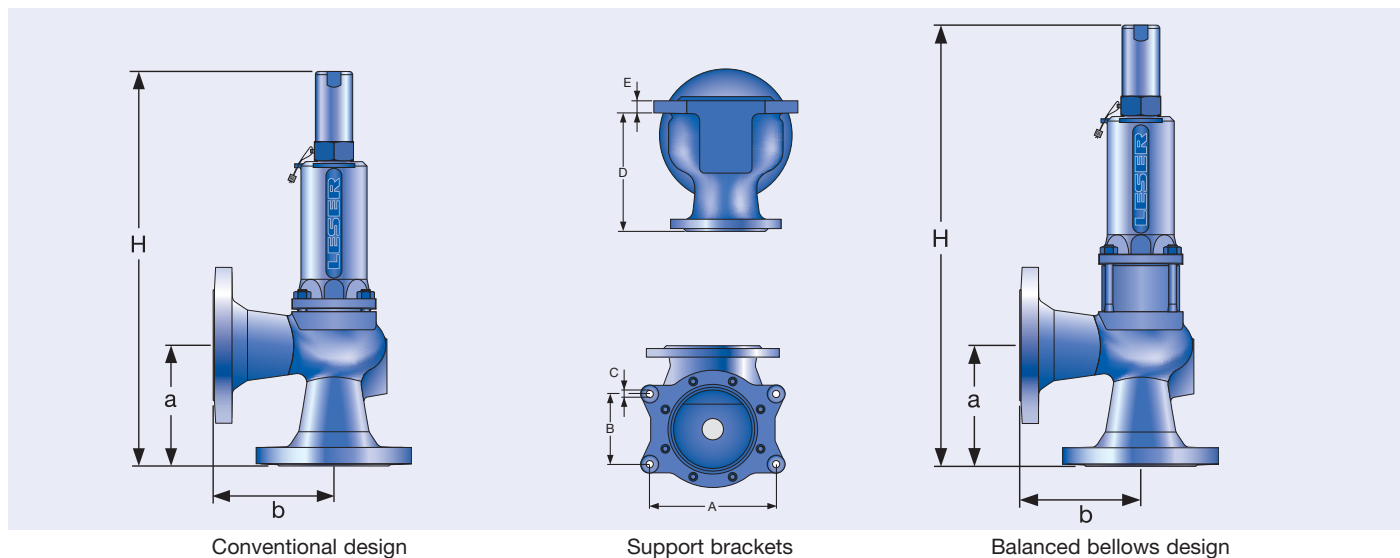

Approvals

Approvals		O-ring disc	Metal disc		
	DN _i	15	15	20	25 – 150
	DN _o	15	15	20	25 – 150
	Actual orifice diameter d _o [mm]	12	12	18	18 – 92
	Actual orifice area A _o [mm ²]	113	113	254	254 – 6648
Europe		Coefficient of discharge K_{dr}			
PED / DIN EN ISO 4126-1	Approval-No.	072020111Z0008/0/06			
	S/G	0.59	0.62	0.29	0.38
	L	0.47	0.48	0.19	0.25
Germany		Coefficient of discharge α_w			
PED / AD 2000-Merkblatt A2 Standard safety valve	Approval-No.	TÜV SV 577			
	S/G	0.59	0.62	0.29	0.38
	L	0.47	0.48	0.19	0.25
China		Coefficient of discharge K			
AQSIQ	Approval-No.	For current Approval-No. see www.leser.com			
	S/G	0.59	0.62	0.29	0.38
	L	0.47	0.48	0.19	0.25
Russia		Coefficient of discharge K			
TR/RTN	Approval-No.	For current Approval-No. see www.leser.com			
	S/G	0.59	0.62	0.29	0.38
	L	0.47	0.48	0.19	0.25
Kazakhstan		Coefficient of discharge α_w			
GOST-K	Approval-No.	For current Approval-No. see www.leser.com			
	S/G	0.59	0.62	0.29	0.38
	L	0.47	0.48	0.19	0.25
Belarus		Coefficient of discharge α_w			
GOSPROMNAZADOR	Approval-No.	For current Approval-No. see www.leser.com			
	S/G	0.59	0.62	0.29	0.38
	L	0.47	0.48	0.19	0.25

Classification societies	Homepage		The valid Approval-No. changes with each renewal of the approval. For a sample certificate including the valid certification number see www.leser.com
Bureau Veritas	BV	www.bureauveritas.com	
ClassNK NIPPON Kaiji Kyokai	NK	www.classnk.or.jp	
Det Norske Veritas	DNV	www.dnv.com	
Germanischer Lloyd	GL	www.gl-group.com	
Lloyd's Register EMEA	LREMEA	www.lr.org	
Registro Italiano Navale	RINA	www.rina.org	

Flange drillings

Flange drillings

		O-ring disc	Metal disc										
		DN _i	15	20	25	32	40	50	65	80	100	125	150
		DN _o	15	20	25	32	40	50	65	80	100	125	150
		Valve size	1/2" x 1/2"	1/2" x 1/2" 3/4" x 3/4"	1" x 1"	1 1/4" x 1 1/4"	1 1/2" x 1 1/2"	2" x 2"	2 1/2" x 2 1/2"	3" x 3"	4" x 4"	5" x 5"	6" x 6"
		Actual orifice diameter d ₀ [mm]	12	18	18	18	23	29	37	46	60	74	92
		Actual orifice area A ₀ [mm ²]	113	254	254	254	416	661	1075	1662	2827	4301	6648
Body material: 0.6025 (cast iron)													
Inlet	DIN EN 1092	PN 10	*	*	*	*	*	*	*	*	*	*	*
		PN 16	*	*	*	*	*	*	*	*	*	*	*
		PN 25	-	-	-	-	-	-	-	-	-	-	-
		PN 40	-	-	-	-	-	-	-	-	-	-	-
Outlet	DIN EN 1092	PN 10	*	*	*	*	*	*	*	*	*	*	*
		PN 16	*	*	*	*	*	*	*	*	*	*	*
Body material: 0.7043 (Ductile Gr. 60-40-18), 1.0619 (WCB), 1.4408 (CF8M)													
Inlet	DIN EN 1092	PN 10	*	*	*	*	*	*	*	H44	H44	H44	H44
		PN 16	*	*	*	*	*	*	*	H45	H45	H45	H45
		PN 25	*	*	*	*	*	*	*	*	*	*	*
		PN 40	*	*	*	*	*	*	*	*	*	*	*
	ASME B16.5	CL150	H64	H64	H64	H64	H64	H64	H64	H64	H64	[H64]	H64
		CL300	[H65]	[H65]	-	H65	H65	-	[H65]	[H65]	-	-	-
Outlet	DIN EN 1092	PN 10	*	*	*	*	*	*	*	H50	H50	H50	H50
		PN 16	*	*	*	*	*	*	*	H51	H51	H51	H51
		PN 25	*	*	*	*	*	*	*	*	*	*	*
		PN 40	*	*	*	*	*	*	*	*	*	*	*
	ASME B16.5	CL150	H79	H79	H79	H79	H79	H79	H79	H79	H79	[H79]	H79
		CL300	H80	H80	-	H80	H80	-	[H80]	[H80]	-	-	-

For an explanation of the characters and symbols, refer to page 00/07.
 Note: Flange drillings and facings always meet the requirements of the given flange standards.
 Flange thickness and outside diameter may deviate from the standard.

Flange facings

Flange facings										
Information		Standard		Inlet		Outlet		Remark		
General										
Flange, undrilled		-		H38		H39				
Linde-V-Nut, Form V48		Linde Standard 420-08		J07		J08		Groove: Rz = 16		
Linde-V-Nut, Form V48A		LWN 313.36		J05		J06		Groove: Rz = 4, e.g. for hydrogen		
Lens-shape seal form L (without lens-shape seal)		DIN 2696 LWN 313.35		J11		J12				
According to DIN EN 1092										
Flange facings				Inlet		Outlet		Remark		
DIN EN 1092 (also see LWN 313.40)				PN 10 – PN 40		PN 10 – PN 40		Rz specification acc. to DIN EN 1092 in µm		
Sealing strip		Form B1		*		*		Seal. strip.: Rz = 12.5 – 50		
		Form B2		L36		L38		Seal. strip.: Rz = 3.2 – 12.5		
Tongue, Form C ¹⁾				H94		H92		only for steel flange		
Groove, Form D ¹⁾				H93		H91				
Male, Form E				H96		H98				
Female, Form F				H97		H99				
O-ring Male, Form G				J01		J02				
O-ring Female, Form H				J03		J04				
According to ASME B16.5										
Body material	Inlet	Outlet	Smooth Finish ²⁾		Serrated Finish		RTJ-Groove			
			Inlet	Outlet	Inlet	Outlet	Inlet		Outlet	
			Option code		Option code		Pressure level	Option code	Pressure level	Option code
0.7043	all	all	L52	L53	*	*	-	-	-	-
1.0619, 1.4408	all	all	L52	L53	*	*	CL150	H62	CL150	H63

¹⁾ LESER manufactures the groove at flanged valves by milling. If a customer demands a turned surface in the soil of the groove according to DIN EN 1092-1 an additional option code is necessary: "S01: soil of the groove drilled".

²⁾ Smooth Finish is not defined in the effective standards.

For signs and symbols refer to page 00/07

Note: Flange drillings and facings meet always the requirements of mentioned flange standards.
Flange thickness and outer diameter may vary from flange standard.

Order information – spare parts

Spare parts

		O-ring disc		Metal disc				
	DN _i	15	15	20	25	32	40	50
	DN _o	15	15	20	25	32	40	50
	Actual orifice diameter d _o [mm]	12	12	18	18	18	23	29
	Actual orifice area A ₀ [mm ²]	113	113	254	254	254	416	661
Disc (item 7): Metal to metal seat		Material-No. / Art.-No.						
Disc	1.4122	–	230.9339.9000	210.6939.9000	210.6939.9000	210.6939.9000	220.0139.9000	220.0239.9000
Detachable lifting aid	1.4404	–	230.9349.9000	210.6949.9000	210.6949.9000	210.6949.9000	220.0149.9000	220.0249.9000
Disc (item 7): Soft seal		Material-No. / Art.-No.						
Disc	CR	“K”	230.3049.9051	–	200.6049.9051	200.6049.9051	200.6049.9051	200.6149.9051
	EPDM	“D”	230.3049.9041	–	200.6049.9041	200.6049.9041	200.6049.9041	200.6149.9041
	FKM	“L”	230.3049.9071	–	200.60049.9071	200.6049.9071	200.6049.9071	200.6149.9071
	FFKM	“C”	230.3049.9091	–	200.60049.9091	200.6049.9091	200.6049.9091	200.6149.9091
O-ring (item 7.4): Soft seal		Material-No. / Art.-No.						
O-Ring	CR	“K”	502.0107.2651	–	502.0171.2651	502.0171.2651	502.0171.2651	502.0249.3351
	EPDM	“D”	502.0107.2641	–	502.0171.2641	502.0171.2641	502.0171.2641	502.0249.3341
	FKM	“L”	502.0107.2671	–	502.0171.2671	502.0171.2671	502.0171.2671	502.0249.3371
	FFKM	“C”	502.0107.2691	–	502.0171.2691	502.0171.2691	502.0171.2691	502.0249.3391
Bellows (item 15): 1.4571		Material-No. / Art.-No.						
Standard bellows	400.7949.0000	400.7949.0000	400.0149.0000	400.0149.0000	400.0149.0000	400.0149.0000	400.0249.0000	400.0349.0000
Conversion kit, standard¹⁾	5021.1030	5021.1030	5021.1034	5021.1034	5021.1034	5021.1034	5021.1035	5021.1036
Low pressure bellows	–	400.0149.0021	400.0149.0021	400.0149.0021	400.0149.0021	400.0149.0021	400.0249.0021	400.0349.0021
Conversion kit low pressure¹⁾	Please specify application conditions							
Gasket – body / bonnet (item 60)		Material-No. / Art.-No.						
Gasket	Graphite + 1.4401	500.0407.0000	500.0407.0000	500.0407.0000	500.0407.0000	500.0407.0000	500.0407.0000	500.0507.0000
Option code L68 Gylon (PTFE compliance)	500.0405.0000	500.0405.0000	500.0405.0000	500.0405.0000	500.0405.0000	500.0405.0000	500.0405.0000	500.0505.0000
Ball (item 61):		Material-No. / Art.-No.						
Ball	Ball Ø [mm]	6	6	6	6	6	6	6
	1.4401	510.0104.0000	510.0104.0000	510.0104.0000	510.0104.0000	510.0104.0000	510.0104.0000	510.0104.0000
Split ring (item 14):		Material-No. / Art.-No.						
Split ring	Spindle Ø [mm]	12	12	12	12	12	12	12
	1.4404	251.0149.0000	251.0149.0000	251.0149.0000	251.0149.0000	251.0149.0000	251.0149.0000	251.0149.0000
Pin (item 57)		Material-No. / Art.-No.						
Pin	1.4310	480.0505.0000	480.0505.0000	480.0505.0000	480.0505.0000	480.0505.0000	480.0505.0000	480.0705.0000
O-ring damper		Material-No. / Art.-No.						
	Conversion kit H2	5021.1060	5021.1060	–	5021.1060	5021.1060	5021.1060	5021.1060
	Conversion kit H4	5021.1064	5021.1064	–	5021.1064	5021.1064	5021.1064	5021.1064

¹⁾ Pressure range, refer to page 01/10 – 01/11

A conversion kit includes the following components:

Item.	Components	No.
8	Guide with bushing	1
11	Bonnet spacer	1
12	Spindle	1
15	Bellows	1
55	Stud	4, 8 dependant on valve size
60	Gasket	2, 3 dependant on valve size
	Installation instruction LWN 037.05	1

Refer to page 01/04

Order information – spare parts

Spare parts							
	DN _i	65	80	100	125	150	
	DN _o	65	80	100	125	150	
	Actual orifice diameter d _o [mm]	37	46	60	74	92	
	Actual orifice area A _o [mm ²]	1075	1662	2827	4301	6648	
Disc (item 7): Metal to metal seat				Material-No. / Art.-No.			
Disc	1.4122	220.0339.9000	210.9639.9000	220.2539.9000	220.2639.9000	220.2739.9000	
Detachable lifting aid	1.4404	220.0349.9000	210.9649.9000	220.2549.9000	–	–	
Disc (item 7): Soft seal				Material-No. / Art.-No.			
Disc	CR	"K"	200.6349.9051	200.6449.9051	200.6549.9051	200.6649.9051	–
	EPDM	"D"	200.6349.9041	200.6449.9041	200.6549.9041	200.6649.9041	200.6749.9041
	FKM	"L"	200.6349.9071	200.6449.9071	200.6549.9071	200.6649.9071	–
	FFKM	"C"	200.6349.9091	200.6449.9091	–	–	–
O-ring (item 7.4): Soft seal				Material-No. / Art.-No.			
O-Ring	CR	"K"	502.0408.3551	502.0503.3551	502.0660.5351	502.0819.5351	–
	EPDM	"D"	502.0408.3541	502.0503.3541	502.0660.5341	502.0819.5341	502.1041.5341
	FKM	"L"	502.0408.3571	502.0503.3571	502.0660.5371	502.0819.5371	–
	FFKM	"C"	502.0408.3591	502.0503.3591	–	–	–
Bellows (item 15): 1.4571				Material-No. / Art.-No.			
Standard bellows		400.0149.0000	400.0549.0000	400.0649.0000	400.0749.0000	400.0849.0000	
Conversion kit, standard¹⁾		5021.1037	5021.1038	5021.1039	Component parts	Component parts	
Low pressure bellows		400.0449.0021	400.0549.0021	400.0649.0021	400.1107	400.0849.0021	
Conversion kit low pressure¹⁾	Please specify application conditions				–	–	
Gasket – body / bonnet (item 60)				Material-No. / Art.-No.			
Gasket	Graphite + 1.4401	500.0907.0000	500.1007.0000	500.1507.0000	500.1807.0000	500.2107.0000	
	Option code L68 Gylon (PTFE compliance)	500.0905.0000	500.1005.0000	500.1505.0000	500.1805.0000	500.2105.0000	
Ball (item 61):				Material-No. / Art.-No.			
Ball	Ball Ø [mm]	9	9	12	12	15	
	1.4404	510.0204.0000	510.0204.0000	510.0304.0000	510.0304.0000	510.0404.0000	
Split ring (item 14):				Material-No. / Art.-No.			
Split ring	Spindle Ø [mm]	16	16	16	20	24	
	1.4404	251.0249.0000	251.0249.0000	251.0249.0000	251.0349.0000	251.0449.0000	
Pin (item 57)				Material-No. / Art.-No.			
Pin	1.4310	480.0705.0000	480.0705.0000	480.1005.0000	480.1005.0000	480.1105.0000	
O-ring damper				Material-No. / Art.-No.			
	Conversion kit H2	5021.1061	5021.1061	–	–	–	
	Conversion kit H4	5021.1065	5021.1065	–	–	–	

¹⁾ Pressure range, refer to page 01/10 – 01/11

A conversion kit includes the following components:

Item.	Components	No.
8	Guide with bushing	1
11	Bonnet spacer	1
12	Spindle	1
15	Bellows	1
55	Stud	4, 8 dependant on valve size
60	Gasket	2, 3 dependant on valve size
	Installation instruction LWN 037.05	1

Refer to page 01/04

Available options

For more information, also see
"Accessories and Options" as of page 99/01.

Heating jacket

H29, H30: Coupling G 3/8, G 3/4
H31, H32: Flange DN15, DN25

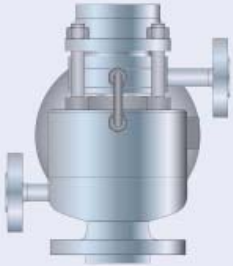

Drain hole

J18: G 1/4
J19: G 1/2

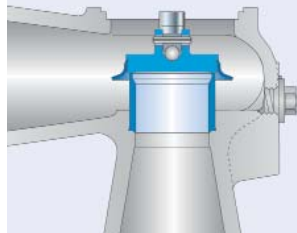

Open bonnet

See Art.-No.

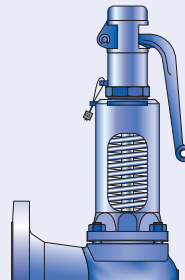

O-ring disc

J20: FFKM "C"
J21: CR "K"
J22: EPDM "D"
J23: FKM "L"

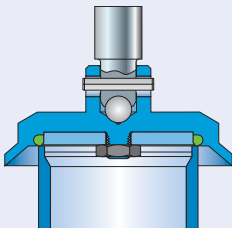

Disc with sealing plate

J68: Open bonnet
J78: Closed bonnet

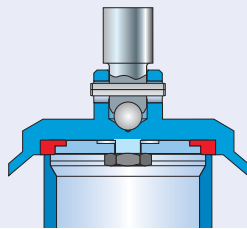

Balanced bellows

J68: Open bonnet
J78: Closed bonnet

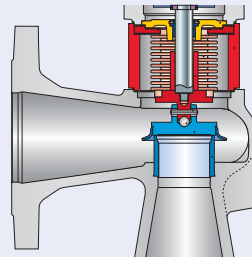

Conversion kit for balanced bellows

Art.-No. see page 01/14

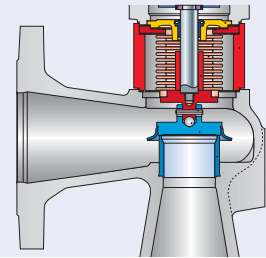

Screwed cap H2

H2

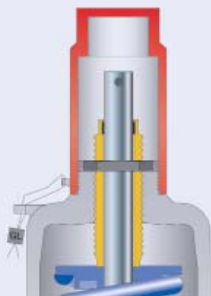

Plain lever H3

H3



Packed lever H4

H4

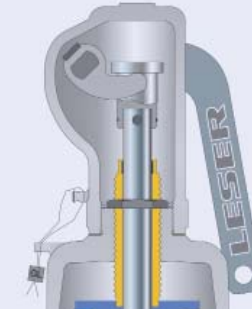

O-ring damper H2

J65

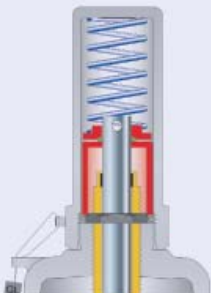

O-ring damper H4

J66

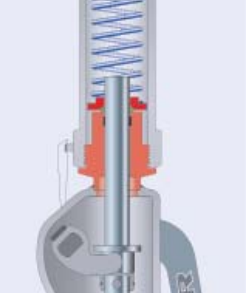

Lift indicator

J39: Adaptor H4
J93: Lift indicator

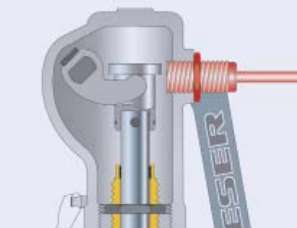

Test gag

J69: H4
J70: H4

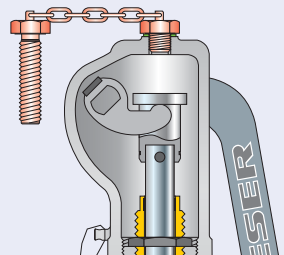

Capacities – steam

Calculation of the capacity for saturated steam acc. to AD 2000-Merkblatt A2 with 10% overpressure.
Capacities at 1 bar and lower are calculated at 0.1 bar overpressure.

Metric units		AD 2000-Merkblatt A2 [kg/h]										
		O-ring disc	Metal disc									
DN _i	15	15	20	25	32	40	50	65	80	100	125	150
DN _o	15	15	20	25	32	40	50	65	80	100	125	150
Actual orifice diameter d _o [mm]	12	12	18	18	18	23	29	37	46	60	74	92
Actual orifice area A _o [mm ²]	113	113	254	254	254	416	661	1075	1662	2827	4301	6648
LEO _{s/g} ^{*)} [inch ²]	0.106	0.111	0.117	0.154	0.154	0.251	0.399	0.650	1.004	1.708	2.598	4.016
Set pressure [bar]	Capacity [kg/h]											
0.2				34	34	55	88	142	220	375	570	880
0.5	52	55	30	63	63	102	163	265	410	697	1060	1638
1	74	78	67	101	101	165	263	428	661	1125	1711	2645
2	118	125	129	170	170	278	442	720	1113	1893	2880	4452
3	161	168	177	232	232	379	603	981	1517	2581	3926	6068
4	200	210	221	290	290	473	752	1224	1892	3218	4895	7567
5		251	265	347	347	566	900	1465	2265	3853	5861	9058
6		293	308	404	404	659	1048	1706	2636	4485	6823	10545
7		333	350	459	459	750	1192	1940	2999	5102	7761	11996
8		374	394	516	516	842	1339	2179	3368	5730	8717	13473
9		415	437	572	572	934	1485	2418	3737	6358	9671	14948
10		456	480	629	629	1026	1632	2656	4105	6984	10624	16421
12		538	566	741	741	1210	1924	3132	4842	8237	12530	19366
14		618	650	852	852	1391	2211	3599	5563	9464	14395	22250
16		699	736	964	964	1574	2503	4074	6297	10714	16296	25189
18		781	822	1077	1077	1758	2795	4550	7033	11965	18200	28131
20		863	908	1190	1190	1942	3088	5027	7770	13218	20107	
22		942	991	1299	1299	2121	3372	5489	8484	14434	21956	
24		1024	1078	1412	1412	2306	3665	5967	9222	15690	23866	
26		1106	1164	1525	1525	2491	3959	6445	9962	16949		
28		1189	1251	1639	1639	2676	4254	6925	10704	18211		
30		1271	1338	1753	1753	2862	4550	7407	11449	19478		
32		1354	1425	1867	1867	3049	4847	7890	12195	20748		
34												
36												
38												
40												

*) LEO_{s/g} = LESER Effective Orifice steam/gases please refer to page 00/11

"How to use" capacity tables, refer to page 00/09

Capacity table – air

Calculation of the capacity for air acc. to AD 2000-Merkblatt A2 with 10% overpressure.
Capacities at 1 bar and lower are calculated at 0.1 bar overpressure.

Metric units		AD 2000-Merkblatt A2 [m_n^3/h]											
		O-ring disc	Metal disc										
	DN _i	15	15	20	25	32	40	50	65	80	100	125	150
	DN _o	15	15	20	25	32	40	50	65	80	100	125	150
	Actual orifice diameter d ₀ [mm]	12	12	18	18	18	23	29	37	46	60	74	92
	Actual orifice area A ₀ [mm ²]	113	113	254	254	254	416	661	1075	1662	2827	4301	6648
	LEO _{SG} ^{*)} [inch ²]	0.106	0.111	0.117	0.154	0.154	0.251	0.399	0.650	1.004	1.708	2.598	4.016
Set pressure [bar]		Capacity [m_n^3/h]											
0.2					39	39	63	101	165	255	431	660	1019
0.5	64	67	35	74	74	120	191	311	481	819	1245	1925	
1	93	93	80	121	121	197	313	510	788	1341	2039	3152	
2	151	151	156	206	206	336	534	870	1344	2287	3478	5377	
3	206	206	217	284	284	463	737	1199	1854	3153	4797	7414	
4	246	258	272	356	356	582	925	1505	2327	3958	6021	9306	
5	296	311	327	429	429	700	1113	1811	2800	4763	7245	11198	
6	346	363	382	501	501	818	1301	2117	3273	5568	8469	13091	
7	396	416	438	574	574	936	1489	2423	3746	6373	9694	14983	
8	446	468	493	646	646	1055	1677	2729	4219	7177	10918	16875	
9	496	521	548	718	718	1173	1865	3035	4692	7982	12142	18767	
10	546	573	604	791	791	1291	2053	3342	5165	8787	13366	20659	
12	646	679	714	936	936	1528	2429	3954	6111	10397	15815	24444	
14	746	784	825	1081	1081	1764	2805	4566	7057	12006	18263	28228	
16	846	889	935	1225	1225	2001	3181	5178	8003	13616	20711	32013	
18	946	994	1046	1370	1370	2237	3557	5790	8949	15226	23160		
20	1046	1099	1156	1515	1515	2474	3933	6402	9895	16835	25608		
22	1146	1204	1267	1660	1660	2710	4309	7014	10842	18445	28057		
24	1245	1309	1377	1805	1805	2947	4685	7626	11788	20055	30505		
26	1345	1414	1488	1950	1950	3183	5061	8238	12734	21664	32954		
28	1445	1519	1599	2095	2095	3420	5437	8851	13680	23274	35402		
30	1545	1624	1709	2240	2240	3656	5813	9463	14626	24883	37850		
32	1645	1729	1820	2384	2384	3893	6189	10075	15572		40299		
34	1745	1834	1930	2529	2529	4130	6565	10687	16518				
36	1845	1939	2041	2674	2674	4366	6941	11299					
38	1945	2044	2151	2819	2819	4603	7317	11911					
40	2045	2149	2262	2964	2964	4839	7693	12523					

^{*)} LEO_{SG} = LESER Effective Orifice steam/gases please refer to page 00/11

"How to use" capacity tables, refer to page 00/09

Capacity table – water

Calculation of the capacity for water acc. to AD 2000-Merkblatt A2 with 10% overpressure at 20 °C.
Capacities at 1 bar and lower are calculated at 0.1 bar overpressure.

Metric units		AD 2000-Merkblatt A2 [10^3kg/h]											
		O-ring disc	Metal disc										
DN _i	15	15	20	25	32	40	50	65	80	100	125	150	
DN _o	15	15	20	25	32	40	50	65	80	100	125	150	
Actual orifice diameter d ₀ [mm]	12	12	18	18	18	23	29	37	46	60	74	92	
Actual orifice area A ₀ [mm ²]	113	113	254	254	254	416	661	1075	1662	2827	4301	6648	
LEO _L ^{*)} [inch ²]	0.127	0.129	0.115	0.152	0.152	0.248	0.394	0.641	0.991	1.686	2.564	3.963	
Set pressure [bar]	Capacity [10^3kg/h]												
0.2				1.77	1.77	2.89	4.60	7.50	11.6	19.7	30.0	46.3	
0.5	2.09	2.14	1.90	2.51	2.51	4.09	6.51	10.6	16.4	27.8	42.4	65.5	
1	2.84	2.90	2.58	3.39	3.39	5.54	8.81	14.3	22.2	37.7	57.4	88.7	
2	4.01	4.10	3.65	4.80	4.80	7.84	12.5	20.3	31.3	53.3	81.1	125	
3	4.91	5.02	4.47	5.88	5.88	9.60	15.3	24.8	38.4	65.3	99.3	154	
4	5.67	5.79	5.16	6.79	6.79	11.1	17.6	28.7	44.3	75.4	115	177	
5	6.34	6.48	5.77	7.59	7.59	12.4	19.7	32.1	49.6	84.3	128	198	
6	6.95	7.09	6.32	8.31	8.31	13.6	21.6	35.1	54.3	92.4	140	217	
7	7.50	7.66	6.82	8.98	8.98	14.7	23.3	37.9	58.6	99.8	152	235	
8	8.02	8.19	7.30	9.60	9.60	15.7	24.9	40.6	62.7	107	162	251	
9	8.51	8.69	7.74	10.2	10.2	16.6	26.4	43.0	66.5	113	172	266	
10	8.97	9.16	8.16	10.7	10.7	17.5	27.9	45.3	70.1	119	181	280	
12	9.82	10.0	8.93	11.8	11.8	19.2	30.5	49.7	76.8	131	199	307	
14	10.6	10.8	9.65	12.7	12.7	20.7	33.0	53.7	82.9	141	215	332	
16	11.3	11.6	10.3	13.6	13.6	22.2	35.2	57.4	88.7	151	229	355	
18	12.0	12.3	10.9	14.4	14.4	23.5	37.4	60.8	94.0	160	243		
20	12.7	13.0	11.5	15.2	15.2	24.8	39.4	64.1	99.1	169	257		
22	13.3	13.6	12.1	15.9	15.9	26.0	41.3	67.3	104	177	269		
24	13.9	14.2	12.6	16.6	16.6	27.1	43.2	70.2	109	185	281		
26	14.5	14.8	13.2	17.3	17.3	28.3	44.9	73.1	113	192	292		
28	15.0	15.3	13.6	18.0	18.0	29.3	46.6	75.9	117	200	304		
30	15.5	15.9	14.1	18.6	18.6	30.3	48.2	78.5	121	207	314		
32	16.0	16.4	14.6	19.2	19.2	31.3	49.8	81.1	125		324		
34	16.5	16.9	15.0	19.8	19.8	32.3	51.4	83.6	129				
36	17.0	17.4	15.5	20.4	20.4	33.2	52.9	86.0					
38	17.5	17.9	15.9	20.9	20.9	34.2	54.3	88.4					
40	17.9	18.3	16.3	21.5	21.5	35.0	55.7	90.7					

*) LEO_L = LESER Effective Orifice liquids, please refer to page 00/11

"How to use" capacity tables, refer to page 00/09

Determination of coefficient of discharge in case of lift restriction or back pressure

- h = Lift [mm]
- d₀ = Flow diameter [mm] of selected safety valve see "Article Numbers" table
- h/d₀ = Ratio of lift / flow diameter
- p_{a0} = Back pressure [bar_a]
- p₀ = Set pressure [bar_a]
- p_{a0}/p₀ = Ratio of back pressure / set pressure
- K_{dr} = Coefficient of discharge acc. to DIN EN ISO 4126-1
- α_w = Coefficient of discharge acc. to AD 2000-Merkblatt A2
- K_b = Back pressure correction factor acc. to API 520 Section 3.3

"How to use" refer to page 00/08

Diagram for evaluation of ratio of lift / flow diameter (h/d₀) in reference to the coefficient of discharge (K_{dr}/α_w)

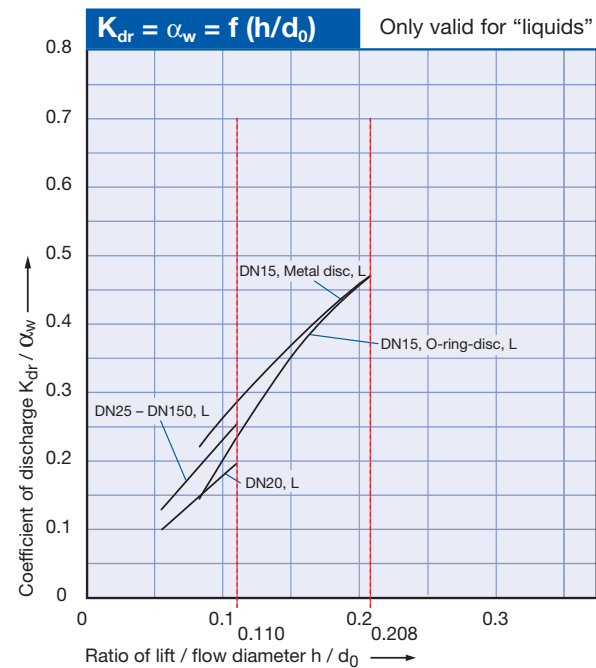
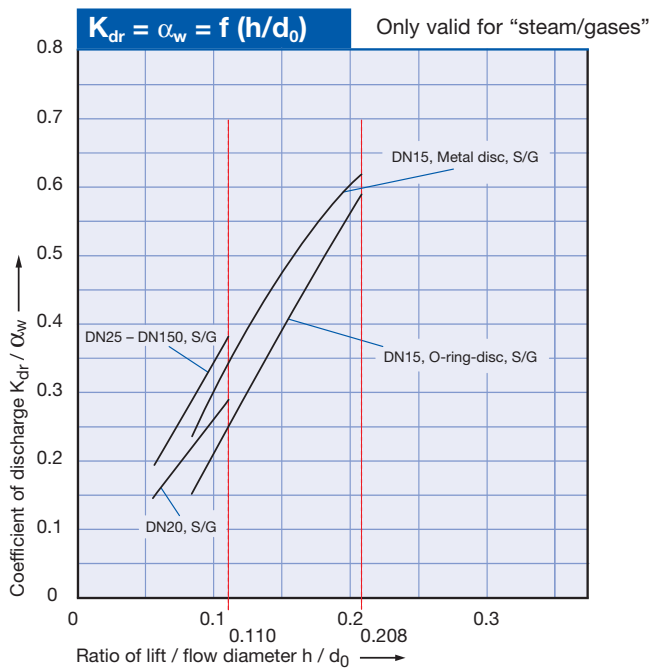
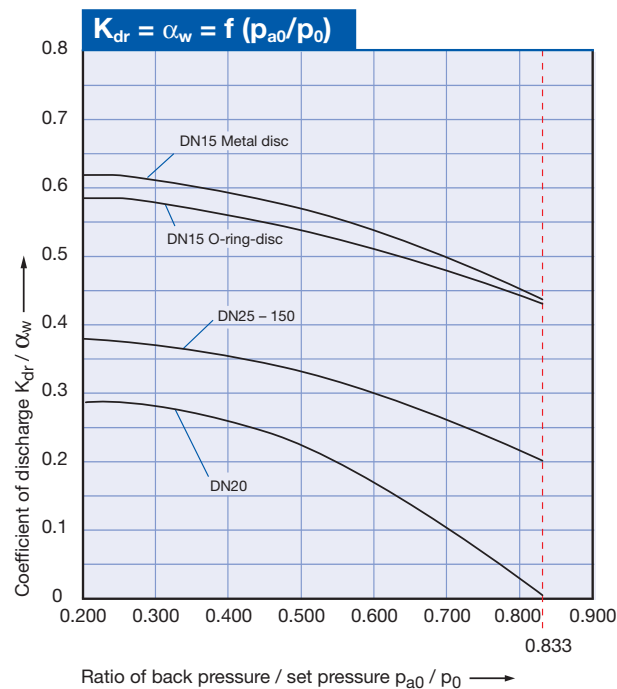

Diagram for evaluation of coefficient of discharge (K_{dr}/α_w) or K_b in reference to the ratio of back pressure / set pressure (p_{a0}/p₀)





Type 431 PN 160
Packed lever H4
Open bonnet
Conventional design

Type 431, 433 PN 160

**Flanged Safety Relief Valves
- spring loaded**



Type 433 PN 160
Cap H2
Closed bonnet
Conventional design

Contents

Chapter/Page

Materials

- Conventional design 02/02
- Balanced bellows design 02/04

How to order

- Numbering system 02/06
- Article numbers 02/08

Pressure temperature ratings

- Metric units 02/09

Dimensions and weights

- Metric units 02/10

Flange drillings and Flange facings 02/11

Order information - spare parts 02/12

Available options 02/13

Approvals 02/14

Capacities

- Steam [Metric units] 02/15
- Air [Metric units] 02/15
- Water [Metric units] 02/15

Determination of 02/16

coefficient of discharge K_{dr}/α_w

Conventional design

Type 433 PN 160

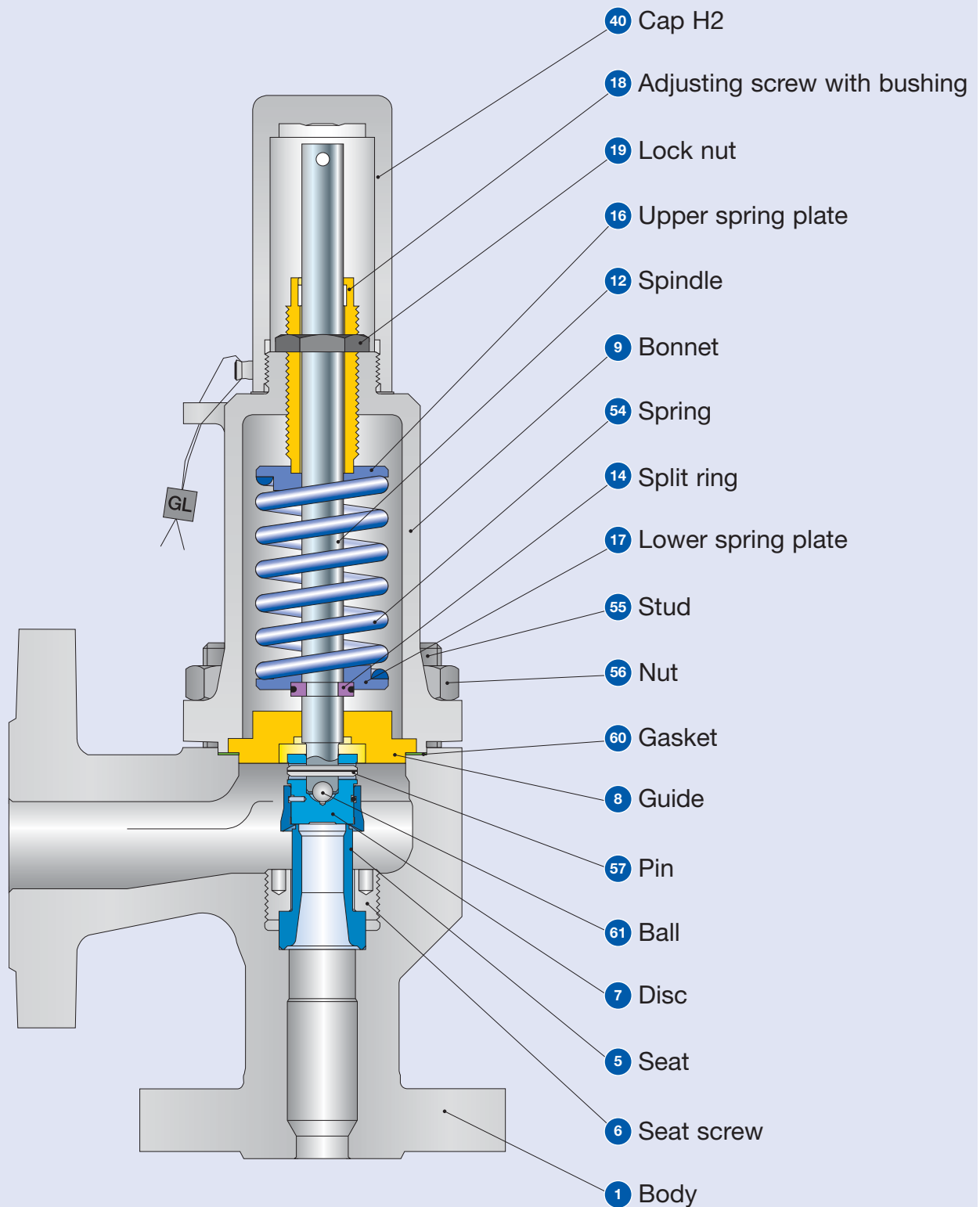

Conventional design

Materials		O-ring disc	Metal disc	O-ring disc	Metal disc
Item	Component	Type 4312 / 4332	Type 4312 / 4332	Type 4334	Type 4334
1	Body	1.0619	1.0619	1.4408	1.4408
		SA 216 WCB	SA 216 WCB	SA 351 CF8M	SA 351 CF8M
5	Seat	1.4404	1.4404	1.4404	1.4404
		316L	316L	316L	316L
6	Seat screw	1.4404	1.4404	1.4404	1.4404
		316L	316L	316L	316L
7	Disc	1.4404	1.4122	1.4404	1.4404
		316L	Hardened stainless steel	316L	316L
8	Guide	1.4104 tenifer	1.4104, 1.0501, 1.0570	1.4404	1.4404
		Chrome steel tenifer	Chrome or stainless steel	316L	316L
9	Bonnet	0.7040	0.7040	1.4408	1.4408
		Ductile Gr. 60-40-18	Ductile Gr. 60-40-18	SA 351 CF8M	SA 351 CF8M
12	Spindle	1.4021	1.4021	1.4404	1.4404
		420	420	316L	316L
14	Split ring	1.4104	1.4104	1.4404	1.4404
		Chrome steel	Chrome steel	316L	316L
16/17	Spring plate	1.0718	1.0718	1.4404	1.4404
		Steel	Steel	316L	316L
18	Adjusting screw with bushing	1.4104 PTFE	1.4104 PTFE	1.4404 PTFE	1.4404 PTFE
		Chrome steel PTFE	Chrome steel PTFE	316L PTFE	316L PTFE
19	Lock nut	1.4104	1.4104	1.4404	1.4404
		Chrome steel	Chrome steel	316L	316L
40	Cap H2	1.0718	1.0718	1.4404	1.4404
		12L13	12L13	316L	316L
54	Spring, standard	1.1200, 1.8159, 1.7102	1.1200, 1.8159, 1.7102	1.4310	1.4310
		Steel	Steel	Stainless steel	Stainless steel
	Spring, optional	1.4310	1.4310	-	-
55	Stud	1.1181	1.1181	1.4401	1.4401
		Steel	Steel	B8M	B8M
56	Nut	1.0501	1.0501	1.4401	1.4401
		2H	2H	8M	8M
57	Pin	1.4310	1.4310	1.4310	1.4310
		Stainless steel	Stainless steel	Stainless steel	Stainless steel
60	Gasket	Graphite / 1.4401	Graphite / 1.4401	Graphite / 1.4401	Graphite / 1.4401
		Graphite / 316	Graphite / 316	Graphite / 316	Graphite / 316
61	Ball	1.3541	1.3541	1.4401	1.4401
		Hardened stainless steel	Hardened stainless steel	316	316

Note:

- LESER reserves the right to make changes.
- If several materials are specified LESER defines the material.
- LESER may use higher quality materials without giving prior notice.
- Each component can be constructed of another material according to the customer's specification.
- All components exposed to pressure are highlighted in bold. The material will be specified according to DIN and ASTM here.

Balanced bellows design

Type 433 PN 160

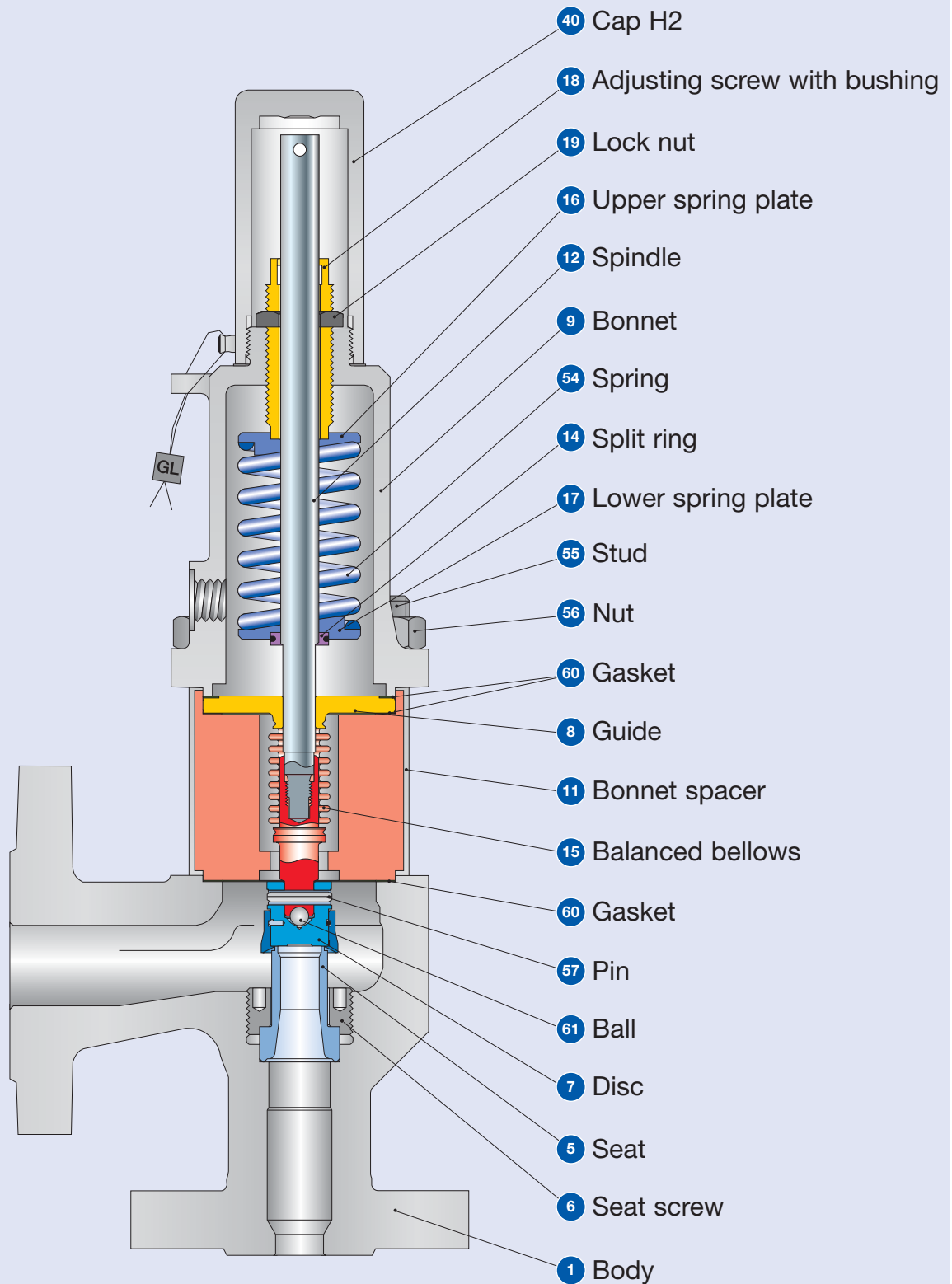

Balanced bellows design

Materials		O-ring disc	Metal disc	O-ring disc	Metal disc
Item	Component	Type 4312 / 4332	Type 4312 / 4332	Type 4334	Type 4334
1	Body	1.0619	1.0619	1.4408	1.4408
		SA 216 WCB	SA 216 WCB	SA 351 CF8M	SA 351 CF8M
5	Seat	1.4404	1.4404	1.4404	1.4404
		316L	316L	316L	316L
6	Seat screw	1.4404	1.4404	1.4404	1.4404
		316L	316L	316L	316L
7	Disc	1.4404	1.4122	1.4404	1.4404
		316L	Hardened stainless steel	316L	316L
8	Guide Upper connection of balanced bellows	1.4404	1.4404	1.4404	1.4404
		316L	316L	316L	316L
9	Bonnet	0.7040	0.7040	1.4408	1.4408
		Ductile Gr. 60-40-18	Ductile Gr. 60-40-18	SA 351 CF8M	SA 351 CF8M
11	Bonnet spacer	1.4404	1.4404	1.4404	1.4404
		316L	316L	316L	316L
12	Spindle	1.4404	1.4404	1.4404	1.4404
		316L	316L	316L	316L
14	Split ring	1.4104	1.4104	1.4404	1.4404
		Chrome steel	Chrome steel	316L	316L
15	Balanced bellows	1.4571	1.4571	1.4571	1.4571
		316Ti	316Ti	316Ti	316Ti
16/17	Spring plate	1.0718	1.0718	1.4404	1.4404
		Steel	Steel	316L	316L
18	Adjusting screw with bushing	1.4104 PTFE	1.4104 PTFE	1.4404 PTFE	1.4404 PTFE
		Chrome steel PTFE	Chrome steel PTFE	316L PTFE	316L PTFE
19	Lock nut	1.4104	1.4104	1.4404	1.4404
		Chrome steel	Chrome steel	316L	316L
40	Cap H2	1.0718	1.0718	1.4404	1.4404
		12L13	12L13	316L	316L
54	Spring, standard	1.1200, 1.8159, 1.7102	1.1200, 1.8159, 1.7102	1.4310	1.4310
	Spring, optional	Steel	Steel	Stainless steel	Stainless steel
55	Stud	1.4310	1.4310	–	–
		Stainless steel	Stainless steel	–	–
55	Stud	1.4401	1.4401	1.4401	1.4401
		8M	8M	B8M	B8M
56	Hex nut	1.4401	1.4401	1.4401	1.4401
		8M	8M	B8M	B8M
57	Roll pin	1.4310	1.4310	1.4310	1.4310
		Stainless steel	Stainless steel	Stainless steel	Stainless steel
60	Gasket	Graphite / 1.4401	Graphite / 1.4401	Graphite / 1.4401	Graphite / 1.4401
		Graphite / 316	Graphite / 316	Graphite / 316	Graphite / 316
61	Ball	1.3541	1.3541	1.4401	1.4401
		Hardened stainless steel	Hardened stainless steel	316	316

Note:

- LESER reserves the right to make changes.
- If several materials are specified LESER defines the material.
- LESER may use higher quality materials without giving prior notice.
- Each component can be constructed of another material according to the customer's specification.
- All components exposed to pressure are highlighted in bold. The material will be specified according to DIN and ASTM here.

How to order – Example for numbering system – Type 433 PN 160

1

Article Number

4332.8552

2

Set Pressure

60 bar

3

Connections

H47

1	2	3	4
433	2	855	2

1 Valve type 431, 433 PN 160
 Type 433 – with closed bonnet
 Type 431 – with open bonnet

2 Material code

Code	Body material
2	1.0619 (WCB)
4	1.4408 (CF8M)

3 Valve code
 Automatically determines nominal diameter and body material (see page 02/08).

4

Code	Lifting device	
2	Gas-tight cap	H2
3	Plain lever	H3
4	Packed lever	H4
5	Plain lever with open bonnet	H3

Please enter the units (in gauge)!

The specified pressure range may not be exceeded!

Please refer to page 02/11.

Type 433 PN 160

4

Options

J22

5

Documentation

H01

L30

6

Code and Medium

2.0

Type 431, 433 PN 160 Option code

- O-ring disc
 - CR "K" **J21**
 - EPDM "D" **J22**
 - FKM "L" **J23**
 - FFKM "C" **J20**
- Disc 1.4404 / 316L **L44**
- Disc 1.4404 / 316L stellited **J25**
- Detachable lifting aid **J26**
- Balanced bellows
 - Bonnet, open (Type 431) **J68**
 - Bonnet, closed (Type 433) **J78**
- High temperature alloy spring **X01**
- Stainless steel spring **X04**
- Adaptor for lift indicator H4 **J39**
- Lift indicator **J93**
- Test gag
 - Cap H2 **J70**
 - Packed lever H4 **J69**
- Heating jacket
 - Couplings G 3/8 **H29**
 - G 3/4 **H30**
 - Flange DN 15 **H31**
 - DN 25 **H32**
- Heating jacket - Bonnet spacer **H33**
- Drain hole G 1/4 **J18**
- G 1/2 **J19**
- Oil and grease free **J85**
- Materials
 - NACE **N78**

Option code applies only if not standard

Please select the necessary documentation:

Tests, Certifications: Option code

DIN EN 10204-3.2: TÜV-Nord
Certification for set pressure **M33**

LESER CGA (Certificate for Global Application) **H03**

- Acceptance test certificate 3.1 acc. to DIN EN 10204
- Declaration of conformity as per pressure equipment directive PED 97/23/EC

Material quality certificate:

DIN EN 10204-3.1

Component Option code

Body	H01
Nozzle	L59
Bonnet	L30
Disc	L23
Screws	N07
Nuts	N08

1 2
2 0

1 Code

2. CE / VdTUEV
3. ASME Section VIII + CE / VdTUEV

2 Medium

.0 steam / gases / liquids
(only valid for CE / VdTUEV)

How to order – article numbers

Article numbers			O-ring disc	Metal disc
	DN _i		15	15
	DN _o		25	25
	Actual orifice diameter d _o [mm]		12	12
	Actual orifice area A ₀ [mm ²]		113	113
Body material: 1.0619 (WCB)				
Bonnet closed	H2	Art.-No. 4332.	8572	8552
	H3	Art.-No. 4332.	8573	8553
	H4	Art.-No. 4332.	8574	8554
open	H3	Art.-No. 4312.	8575	8555
Body material: 1.4408 (CF8M)				
Bonnet closed	H2	Art.-No. 4334.	8582	8562
	H4	Art.-No. 4334.	8584	8564

Type 433 PN 160

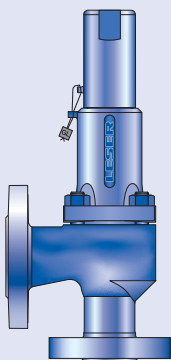

Type 433 PN 160
Cap H2
Closed bonnet
Conventional design

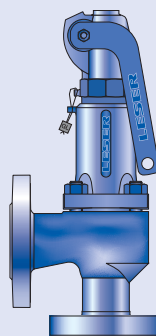

Type 433 PN 160
Packed lever H4
Closed bonnet
Conventional design

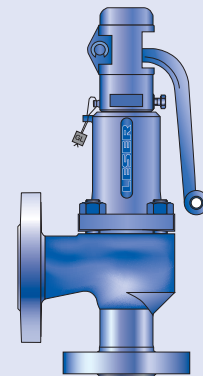

Type 433 PN 160
Plain lever H3
Closed bonnet
Conventional design

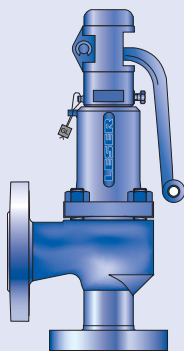

Type 431 PN 160
Plain lever H3
Open bonnet
Conventional design

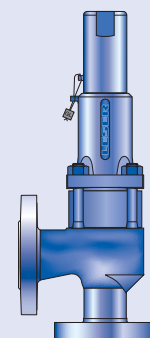

Type 431 PN 160
Plain lever H3
Closed bonnet
Balanced bellows design

Pressure temperature ratings

Metric units						
			O-ring disc		Metal disc	
	DN _i		15		15	
	DN _o		25		25	
	Actual orifice diameter d ₀ [mm]		12		12	
	Actual orifice area A ₀ [mm ²]		113		113	
Body material: 1.0619 (WCB)						
DIN flange	Inlet	PN 160				
	Outlet	PN 40				
Minimum set pressure	p [bar _g] S/G/L	0.3			0.3	
Min. set pressure¹⁾ standard bellows	p [bar _g] S/G/L	3			3	
Maximum set pressure	p [bar _g] S/G/L	"K"			144	
		"D"	142	"C"		85
		"L"				
Max. set pressure with special spring	p [bar _g] S/G/L	"K"			160	
		"D"	160	"C"		85
		"L"				
Temperature²⁾ acc. to DIN EN	min. [°C]	-45			-60	
	max. [°C]	+150			+450	
Body material: 1.4408 (CF8M)						
DIN flange	Inlet	PN 160				
	Outlet	PN 40				
Minimum set pressure	p [bar _g] S/G/L	0.3			0.3	
Min. set pressure¹⁾ standard bellows	p [bar _g] S/G/L	3			3	
Max. set pressure	p [bar _g] S/G/L	85			85	
Max. set pressure with special spring	p [bar _g] S/G/L	"K"			160	
		"D"	150	"C"		85
		"L"				
Temperature²⁾ acc. to DIN EN	min. [°C]	-45			-270	
	max. [°C]	+150			+400	

¹⁾ Min. set pressure of standard bellows = max. set pressure of bellows for low set pressure.

²⁾ The temperature is limited by the soft seal material (see page 99/10). The values given here are valid for EPDM. Between -10°C and the lowest specified application temperature, proceed as per AD 2000-Merkblatt W10.

Dimensions and weights

Metric units		
	DN _i	15
	DN _o	25
	Actual orifice diameter d ₀ [mm]	12
	Actual orifice area A ₀ [mm ²]	113
Weight		
[kg]		7
	with bellows	8.4
Centre to face		
[mm]	Inlet a	90
	Outlet b	90
Height (H4)		
[mm]	Standard H max.	307
	Bellows H max.	359
Body material: 1.0619 (WCB)		
DIN flange¹⁾	Inlet	PN 160
	Outlet	PN 40
Body material: 1.4408 (CF8M)		
DIN flange¹⁾	Inlet	PN 160
	Outlet	PN 40

¹⁾ Standard flange class. For other flange drillings, see page 02/11.

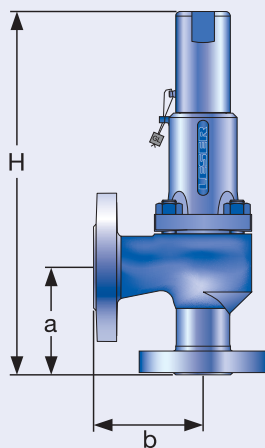

Conventional design

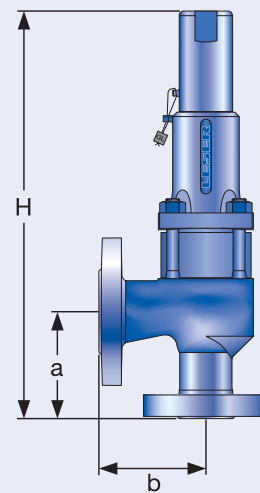

Balanced bellows design

Flange drillings and facings

Flange drillings			
DN _i	15		
DN _o	25		
Valve size	1/2" x 1"		
Actual orifice diameter d _o [mm]	12		
Actual orifice area A _o [mm ²]	113		
Body material: 1.0619 (WCB), 1.4408 (CF8M)			
Inlet	DIN EN 1092	PN 16	H47
		PN 40	H47
		PN 63	*
		PN 160	*
	ASME B 16.5	CL300	H65
		CL600	H67
Outlet	DIN EN 1092	PN 16	*
		PN 40	*
	ASME B16.5 ¹⁾	CL150	H79
		CL300	H80

Flange facings		Information	Standard	Inlet	Outlet	Remark				
General										
		Flange, undrilled	-	H38	H39					
		Linde-V-Nut, Form V48	Linde Standard 420-08	J07	J08	Groove: Rz = 16				
		Linde-V-Nut, Form V48A	LWN 313.36	J05	J06	Groove: Rz = 4, e.g. for hydrogen				
		Lens-shape seal form L (without lens-shape seal)	DIN 2696 LWN 313.35	J11	J12					
According to DIN EN 1092										
		Flange facings		Inlet	Outlet	Remark				
		DIN EN 1092 (also see LWN 313.40)		PN 63 – PN 160	PN 40	Rz specification acc. to DIN EN 1092 in µm				
		Sealing strip	Form B1	-	*	Seal. strip.: Rz = 12.5 – 50				
			Form B2	*	L38	Seal. strip.: Rz = 3.2 – 12.5				
		Tongue, Form C ¹⁾		H94	H92	only for steel flange				
		Groove, Form D ¹⁾		H93	H91					
		Male, Form E		H96	H98					
		Female, Form F		H97	H99					
		O-ring Male, Form G		J01	J02					
		O-ring Female, Form H		J03	J04					
According to ASME B16.5										
Body material	Inlet	Outlet	Smooth Finish ²⁾		Serrated Finish		RTJ-Groove			
			Inlet	Outlet	Inlet	Outlet	Inlet		Outlet	
			Option code		Option code		Pressure level	Option code	Pressure level	Option code
1.0619, 1.4408	all	all	L52	L53	*	*	CL150	H62	CL150	H63

¹⁾ LESER manufactures the groove at flanged valves by milling. If a customer demands a turned surface in the soil of the groove according to DIN EN 1092-1 an additional option code is necessary: "S01: soil of the groove drilled".

²⁾ Smooth Finish is not defined in the effective standards.

For signs and symbols refer to page 00/07
 Note: Flange drillings and facings meet always the requirements of mentioned flange standards.
 Flange thickness and outer diameter may vary from flange standard.

Order information – spare parts

Spare parts

		O-ring disc	Metal disc
	DN _i	15	15
	DN _o	25	25
	Actual orifice diameter d ₀ [mm]	12	12
	Actual orifice area A ₀ [mm ²]	113	113
Disc (item 7): Metal seat		Material-No. / Art.-No.	
Disc	1.4122	–	230.9339.9000
Detachable lifting aid	1.4404	–	230.9349.9000
Disc (item 7): Soft seal		Material-No. / Art.-No.	
Disc	CR “K”	230.2949.9053	–
	EPDM “D”	230.2949.9042	–
	FKM “L”	230.2949.9073	–
	FFKM “C”	230.2949.9091	–
O-ring (item 7.4): Soft seal		Material-No. / Art.-No.	
O-Ring	CR “K”	502.0107.2653	–
	EPDM “D”	502.0107.2642	–
	FKM “L”	502.0107.2673	–
	FFKM “C”	502.0107.2691	–
Bellows (item 15): 1.4571		Material-No. / Art.-No.	
Standard bellows		400.6349.0000	400.6349.0000
Conversion kit, standard¹⁾		Please specify application conditions	
Low pressure bellows		–	–
Conversion kit low pressure¹⁾		–	–
Gasket – body / bonnet (item 60)		Material-No. / Art.-No.	
Gasket	Graphite + 1.4401	500.0407.0000	500.0407.0000
Option code L68 Gylon (PTFE compliance)		500.0405.0000	500.0405.0000
Ball (item 61):		Material-No. / Art.-No.	
Ball	Ball Ø [mm]	6	6
	1.4404	510.0104.0000	510.0104.0000
Split ring (item 14):		Material-No. / Art.-No.	
Split ring	Spindle Ø [mm]	12	12
	1.4404	251.0149.0000	251.0149.0000
Pin (item 57)		Material-No. / Art.-No.	
Pin	1.4310	480.0505.0000	480.0505.0000
O-ring damper		Material-No. / Art.-No.	
	Conversion kit H2	5021.1060	5021.1060
	Conversion kit H4	5021.1064	5021.1064

Item.	Components	No.
8	Guide; upper connection of balanced bellows	1
11	Bonnet spacer	1
12	Spindle	1
15	Bellows	1
55	Stud	4
60	Gasket	2
	Instruction guide LWN 037.05	1

Refer to page page 02/04

Available options

For more information, also see
"Accessories and Options" as of page 99/01.

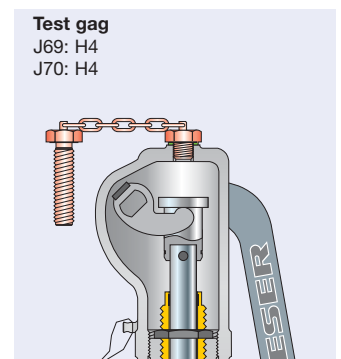
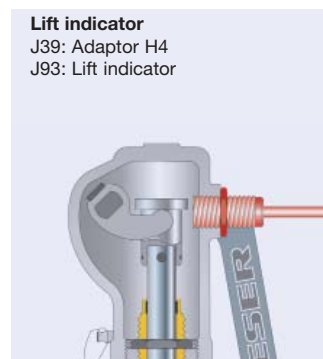
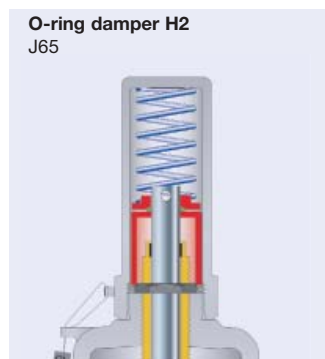
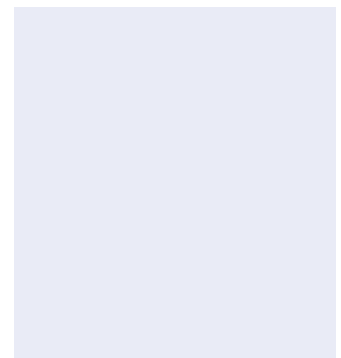
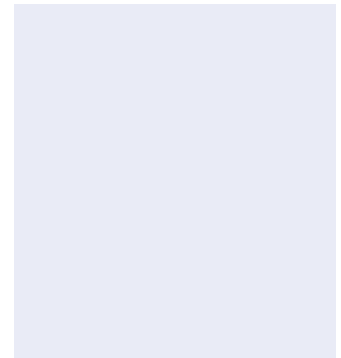
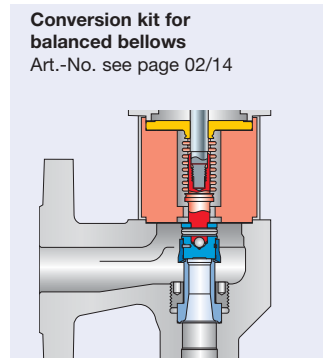
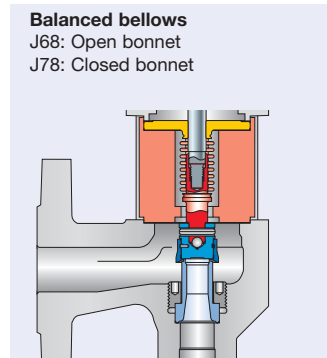
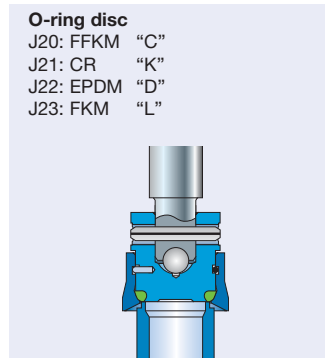
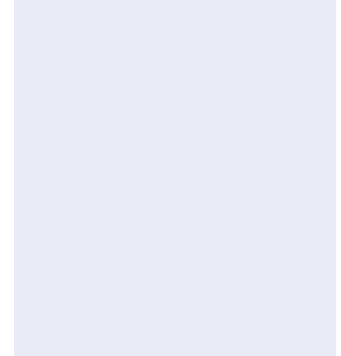
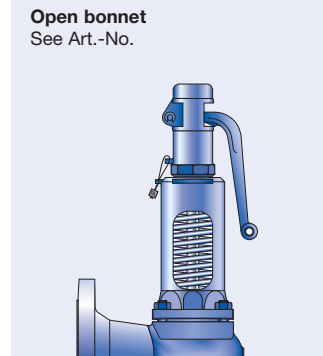
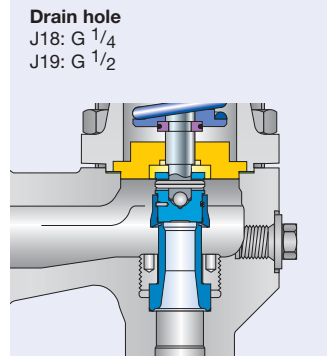
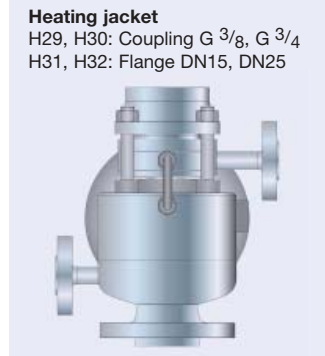

Type 433 PN 160

Approvals

Approvals		O-ring disc	Metal disc
	DN _i	15	15
	DN _o	25	25
	Actual orifice diameter d ₀ [mm]	12	12
	Actual orifice area A ₀ [mm ²]	113	113
Europe		Coefficient of discharge K_{dr}	
PED / DIN EN ISO 4126-1	Approval-No.	072020111Z0008/0/06	
	S/G	0.59	0.62
	L	0.47	0.48
Germany		Coefficient of discharge α_w	
PED / AD 2000-Merkblatt A2 Standard safety valve	Approval-No.	TÜV SV 577	
	S/G	0.59	0.62
	L	0.47	0.48
China		Coefficient of discharge K	
AQSIQ	Approval-No.	For current Approval-No. see www.leser.com	
	S/G	0.59	0.62
	L	0.47	0.48
Russia		Coefficient of discharge K	
TR/ RTN	Approval-No.	For current Approval-No. see www.leser.com	
	S/G	0.59	0.62
	L	0.47	0.48
Kazakhstan		Coefficient of discharge α_w	
GOST-K	Approval-No.	For current Approval-No. see www.leser.com	
	S/G	0.59	0.62
	L	0.47	0.48
Belarus		Coefficient of discharge α_w	
GOSPROMNAZADOR	Approval-No.	For current Approval-No. see www.leser.com	
	S/G	0.59	0.62
	L	0.47	0.48

Classification societies	Homepage	
Bureau Veritas	BV	www.bureauveritas.com
ClassNK NIPPON Kaiji Kyokai	NK	www.classnk.or.jp
Det Norske Veritas	DNV	www.dnv.com
Germanischer Lloyd	GL	www.gl-group.com
Lloyd's Register EMEA	LREMEA	www.lr.org
Registro Italiano Navale	RINA	www.rina.org

The valid Approval-No. changes with each renewal of the approval.

For a sample certificate including the valid certification number see www.leser.com

Capacities

Calculation of the capacity for steam, gases, and liquids acc. to AD 2000-Merkblatt A2 with 10% overpressure.
Capacities at 1 bar and lower are calculated at 0.1 bar overpressure.

Metric units		AD 2000-Merkblatt A2					
		O-ring disc	Metal disc	O-ring disc	Metal disc	O-ring disc	Metal disc
DN		15	15	15	15	15	15
DN ₀		25	25	25	25	25	25
Actual orifice diameter d ₀ [mm]		12	12	12	12	12	12
Actual orifice area A ₀ [mm ²]		113	113	113	113	113	113
LEO _{S/G/L} ^{*)} [inch ²]		0.106	0.111	0.106	0.111	0.127	0.129
Set pressure	Capacities		Capacities		Capacities		
[bar]	Steam saturated [kg/h]		Air 0°C and 1013 mbar [m ³ /h]		Water 20°C [10 ³ kg/h]		
0.2							
0.5	52	55	64	67	2.09	2.14	
1	74	78	93	93	2.84	2.90	
2	118	125	151	151	4.01	4.10	
3	161	168	206	206	4.91	5.02	
4	200	210	246	258	5.67	5.79	
5		251	296	311	6.34	6.48	
6		293	346	363	6.95	7.09	
7		333	396	416	7.50	7.66	
8		374	446	468	8.02	8.19	
9		415	496	521	8.51	8.69	
10		456	546	573	8.97	9.16	
12		538	646	679	9.82	10.0	
14		618	746	784	10.6	10.8	
16		699	846	889	11.3	11.6	
18		781	946	994	12.0	12.3	
20		863	1046	1099	12.7	13.0	
22		942	1146	1204	13.3	13.6	
24		1024	1245	1309	13.9	14.2	
26		1106	1345	1414	14.5	14.8	
28		1189	1445	1519	15.0	15.3	
30		1271	1545	1624	15.5	15.9	
32		1354	1645	1729	16.0	16.4	
34		1433	1745	1834	16.5	16.9	
36		1517	1845	1939	17.0	17.4	
38		1600	1945	2044	17.5	17.9	
40		1684	2045	2149	17.9	18.3	
50		2109	2545	2674	20.1	20.5	
60		2537	3045	3200	22.0	22.4	
70		2981	3545	3725	23.7	24.2	
80		3430	4045	4250	25.4	25.9	
90		3901	4544	4775	26.9	27.5	
100			5044	5301	28.4	29.0	
120			6044	6351	31.1	31.7	
140			7044	7402	33.6	34.3	
160			8043	8452	35.9	36.6	

*) LEO_{S/G/L} = LESER Effective Orifice for steam, gases, and liquids, please refer to page 00/11
"How to use" capacity tables, refer to page 00/09

Determination of coefficient of discharge in case of lift restriction or back pressure

- h = Lift [mm]
- d_0 = Flow diameter [mm] of selected safety valve see "Article Numbers" table
- h/d_0 = Ratio of lift / flow diameter
- p_{a0} = Back pressure [bar_a]
- p_0 = Set pressure [bar_a]
- p_{a0}/p_0 = Ratio of back pressure / set pressure
- K_{dr} = Coefficient of discharge acc. to DIN EN ISO 4126-1
- α_w = Coefficient of discharge acc. to AD 2000-Merkblatt A2
- K_b = Back pressure correction factor acc. to API 520 Section 3.3

Diagram for evaluation of ratio of lift / flow diameter (h/d_0) in reference to the coefficient of discharge K_{dr}/α_w

"How to use" refer to page 00/08

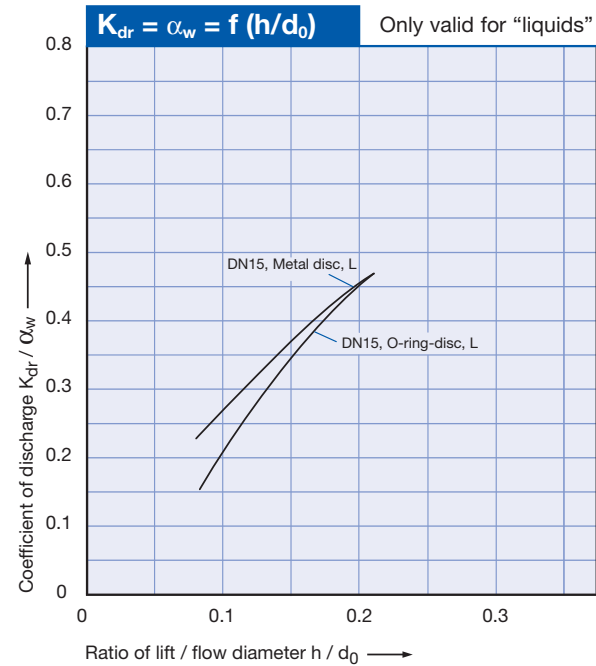
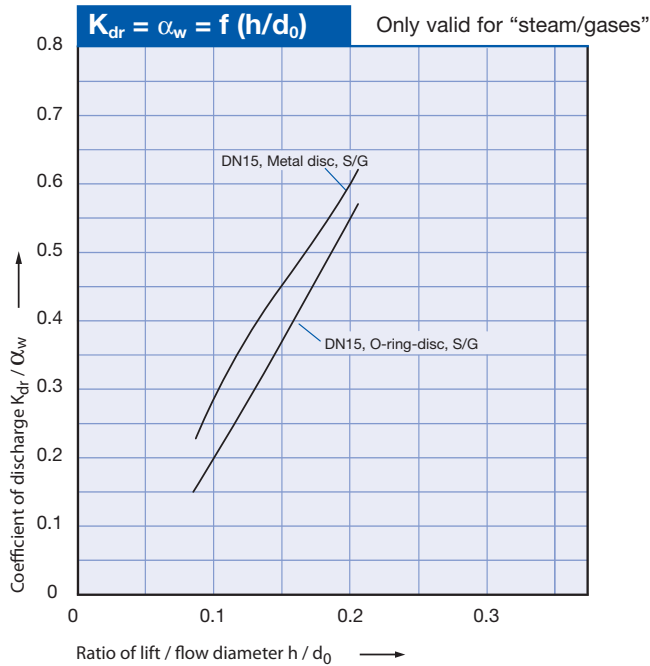
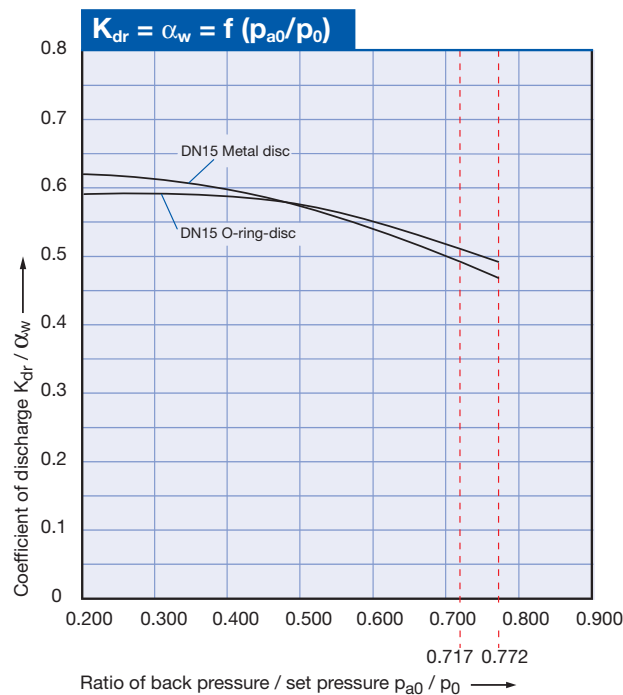

Diagram for evaluation of coefficient of discharge (K_{dr}/α_w) or K_b in reference to the ratio of back pressure / set pressure (p_{a0}/p_0)



Type 427, 429



Type 427
Plain lever H3
Open bonnet
Conventional design

Flanged Safety Relief Valves – spring loaded

Contents

Chapter/Page

Materials

- Conventional design 03/02
- Balanced bellows design 03/04

How to order

- Numbering system 03/06
- Article numbers 03/08

Pressure temperature ratings

- Metric units 03/10

Dimensions and weights

- Metric units 03/12

Flange drillings and facings 03/13

Order information - spare parts 03/14

Available options 03/16

Approvals 03/17

Capacities

- Steam [Metric units] 03/18
- Air [Metric units] 03/19
- Water [Metric units] 03/20



Type 429
Cap H2
Closed bonnet
Conventional design

Conventional design

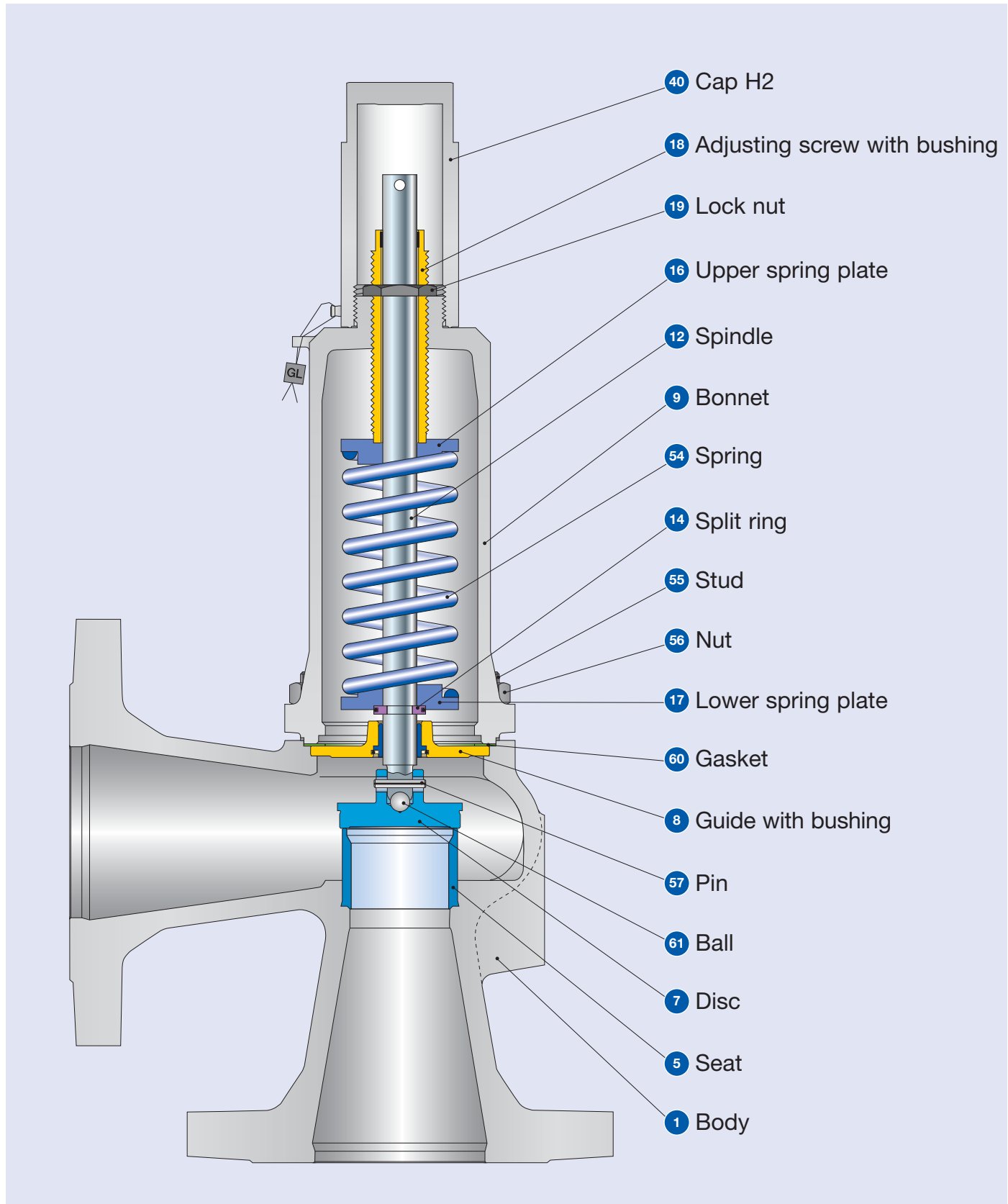

Type 429

Conventional design

Materials				
Item	Component	Type 4275 / 4295	Type 4272 / 4292	Type 4294
1	Body	0.7043	1.0619	1.4408
		Ductile Gr. 60-40-18	SA 216 WCB	SA 351 CF8M
5	Seat	1.4404	1.4404	1.4404
		316L	316L	316L
7	Disc	1.4122	1.4122	1.4404
		Hardened stainless steel	Hardened stainless steel	316L
8	Guide	1.4104, 1.0501	1.4104, 1.0501, 1.0570	1.4404
		Chrome steel or steel	Chrome steel or steel	316L
	with bushing	1.4104 tenifer	1.4104 tenifer	-
		Chrome steel tenifer	Chrome steel tenifer	-
9	Bonnet	0.7040	0.7040	1.4408, 1.4404
		Ductile Gr. 60-40-18	Ductile Gr. 60-40-18	SA 351 CF8M, SA 479 316 L
12	Spindle	1.4021	1.4021	1.4404
		420	420	316L
14	Split ring	1.4104	1.4104	1.4404
		Chrome steel	Chrome steel	316L
16/17	Spring plate	1.0718	1.0718	1.4404
		Steel	Steel	316L
18	Adjusting screw with bushing	1.4104 PTFE	1.4104 PTFE	1.4404 PTFE
		Chrome steel PTFE	Chrome steel PTFE	316L PTFE
19	Lock nut	1.0718	1.0718	1.4404
		Steel	Steel	316L
40	Cap H2	1.0718	1.0718	1.4404
		12L13	12L13	316L
54	Spring, standard	1.1200, 1.8159, 1.7102	1.1200, 1.8159, 1.7102	1.4310
		Steel	Steel	Stainless steel
	Spring, optional	1.4310	1.4310	-
		Stainless steel	Stainless steel	-
55	Stud	1.1181	1.1181	1.4401
		Steel	Steel	B8M
56	Nut	1.0501	1.0501	1.4401
		2H	2H	8M
57	Pin	1.4310	1.4310	1.4310
		Stainless steel	Stainless steel	Stainless steel
60	Gasket	Graphite / 1.4401	Graphite / 1.4401	Graphite / 1.4401
		Graphite / 316	Graphite / 316	Graphite / 316
61	Ball	1.3541	1.3541	1.4401
		Hardened stainless steel	Hardened stainless steel	316

Note:

- LESER reserves the right to make changes.
- If several materials are specified LESER defines the material.
- LESER may use higher quality materials without giving prior notice
- Each component can be constructed of another material according to the customer's specification.
- All components exposed to pressure are highlighted in bold. The material will be specified according to DIN and ASTM here.

Type 427, 429

LESER

Balanced bellows design

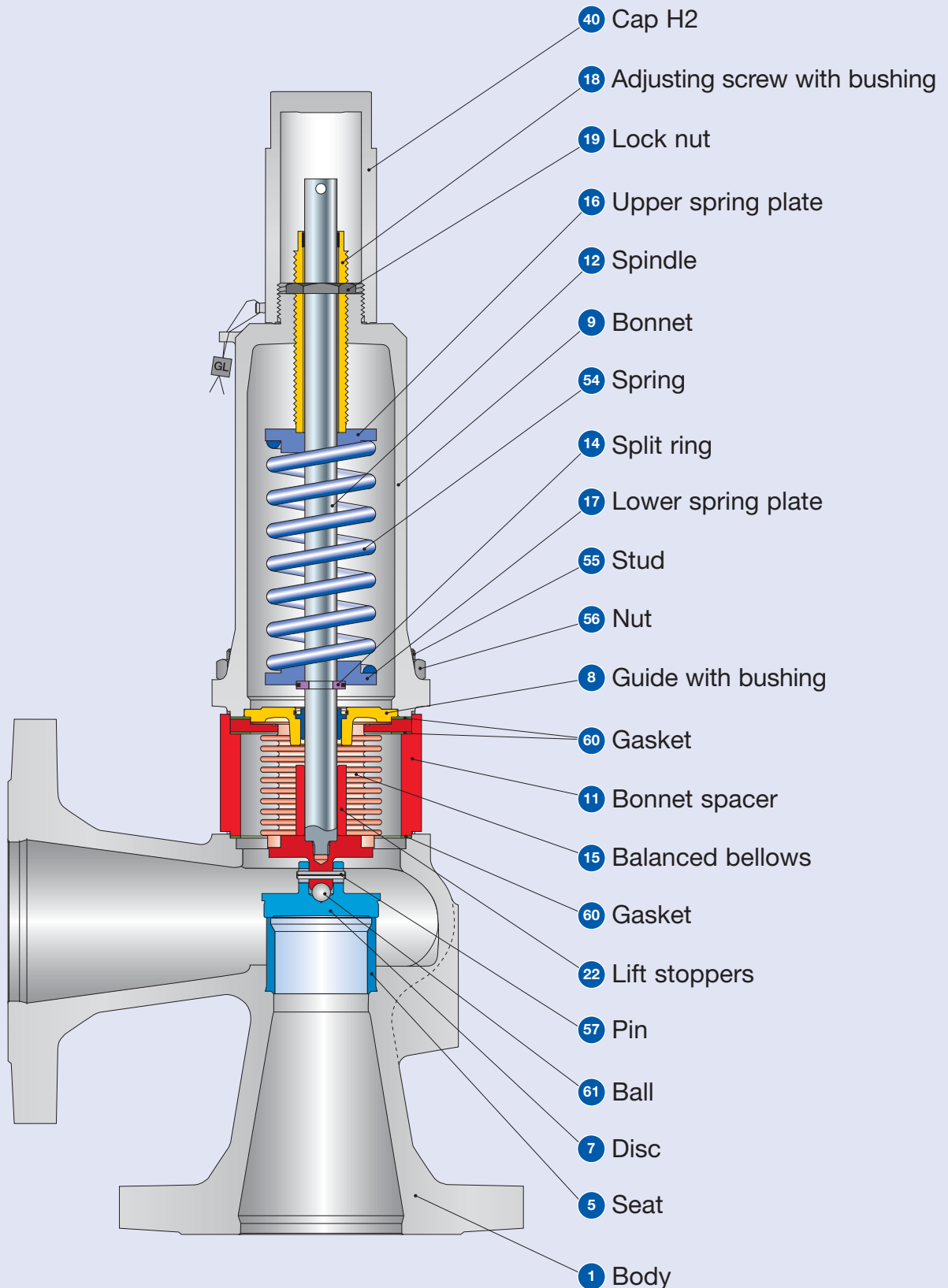

Type 429

Balanced bellows design

Materials				
Item	Component	Type 4275 / 4295	Type 4272 / 4292	Type 4294
1	Body	0.7043	1.0619	1.4408
		Ductile Gr. 60-40-18	SA 216 WCB	SA 351 CF8M
5	Seat	1.4404	1.4404	1.4404
		316L	316L	316L
7	Disc	1.4122	1.4122	1.4404
		Hardened stainless steel	Hardened stainless steel	316L
8	Guide	1.4104, 1.0501	1.4104, 1.0501, 1.0570	1.4404
		Chrome steel or steel	Chrome steel or steel	316L
	with bushing	1.4104 tenifer	1.4104 tenifer	-
		Chrome steel tenifer	Chrome steel tenifer	-
9	Bonnet	0.7040	0.7040	1.4408
		Ductile Gr. 60-40-18	Ductile Gr. 60-40-18	SA 351 CF8M
11	Bonnet spacer	1.4404	1.4404	1.4404
		316L	316L	316L
12	Spindle	1.4404	1.4404	1.4404
		316L	316L	316L
14	Split ring	1.4104	1.4104	1.4404
		Chrome steel	Chrome steel	316L
15	Balanced bellows	1.4571	1.4571	1.4571
		316Ti	316Ti	316Ti
16/17	Spring plate	1.0718	1.0718	1.4404
		Steel	Steel	316L
18	Adjusting screw with bushing	1.4104 PTFE	1.4104 PTFE	1.4404 PTFE
		Chrome steel PTFE	Chrome steel PTFE	316L PTFE
19	Lock nut	1.0718	1.0718	1.4404
		Steel	Steel	316L
22	Lift stoppers	1.4404	1.4404	1.4404
		316L	316L	316L
40	Cap H2	1.0718	1.0718	1.4404
		12L13	12L13	316L
54	Spring, standard	1.1200, 1.8159, 1.7102	1.1200, 1.8159, 1.7102	1.4310
		Steel	Steel	Stainless steel
	Spring, optional	1.4310	1.4310	-
		Stainless steel	Stainless steel	-
55	Stud	1.4401	1.4401	1.4401
		8M	B8M	B8M
56	Nut	1.4401	1.4401	1.4401
		8M	B8M	B8M
57	Pin	1.4310	1.4310	1.4310
		Stainless steel	Stainless steel	Stainless steel
60	Gasket	Graphite / 1.4401	Graphite / 1.4401	Graphite / 1.4401
		Graphite / 316	Graphite / 316	Graphite / 316
61	Ball	1.3541	1.3541	1.4401
		Hardened stainless steel	Hardened stainless steel	316

Note:

- LESER reserves the right to make changes.
- If several materials are specified LESER defines the material.
- LESER may use higher quality materials without giving prior notice
- Each component can be constructed of another material according to the customer's specification.
- All components exposed to pressure are highlighted in bold. The material will be specified according to DIN and ASTM here.

How to order – Example for numbering system – Type 429

<h1>1</h1> <p>Article Number</p>	<h1>2</h1> <p>Set Pressure</p>	<h1>3</h1> <p>Connections</p>
4292.7172	5 bar	H45

1	2	3	4
429	2	717	2

1 Valve type 427, 429
 Type 429 – with closed bonnet
 Type 427 – with open bonnet

2 Material code

Code	Body material
2	1.0619 (WCB)
4	1.4408 (CF8M)
5	0.7043 (Ductile Gr. 60-40-18)

3 Valve code
 Automatically determines nominal diameter and body material (see page 03/09).

4

Code	Lifting device	
2	Gas-tight cap	H2
3	Plain lever	H3
4	Packed lever	H4
5	Plain lever with open bonnet	H3

Please enter the units (in gauge)!

The specified pressure range may not be exceeded!

Please refer to page 03/13.

Type 429

4 Options

J22

Type 427, 429	Option code
• O-ring disc	
CR "K"	J21
EPDM "D"	J22
FKM "L"	J23
FFKM "C"	J20
• Disc 1.4404 / 316L	L44
• Disc 1.4404 / 316L stellited	J25
• Balanced bellows	
- Bonnet, open (Type 427)	J68
- Bonnet, closed (Type 429)	J78
• Elastomer bellows	J79
• High temperature alloy spring	X01
• Stainless steel spring	X04
• Adapter for lift indicator H4	J39
• Lift indicator	J93
• Test gag	
- Cap H2	J70
- Packed lever H4	J69
• O-ring damper	
- Cap H2	J65
- Packed lever H4	J66
• Heating jacket	
- Couplings G 3/8	H29
G 3/4	H30
- Flange DN 15	H31
DN 25	H32
• Drain hole G 1/4	J18
G 1/2	J19
• Oil and grease free	J85
• Materials	
- NACE	N78

Option code applies only if not standard

5 Documentation

H01 L30

Please select the necessary documentation:

Tests, Certifications:	Option code
DIN EN 10204-3.2: TÜV-Nord Certification for set pressure	M33
LESER CGA (Certificate for Global Application)	H03
- Acceptance test certificate 3.1 acc.to DIN EN 10204	
- Declaration of conformity as per pressure equipment directive PED 97/23/EC	
Material quality certificate:	
DIN EN 10204-3.1	
Component	Option code
Body	H01
Bonnet	L30
Cap / lever cover	L31
Disc	L23
Screws	N07
Nuts	N08

6 Code and Medium

2.0

1	2
2	0
1 Code	
2. CE / VdTUEV	
3. ASME Section VIII + CE / VdTUEV	
2 Medium	
.0 steam / gases / liquids (only valid for CE / VdTUEV)	

How to order – Article numbers

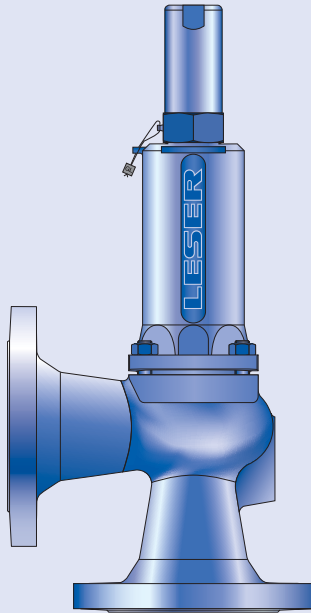

Type 429
Cap H2
Closed bonnet
Conventional design

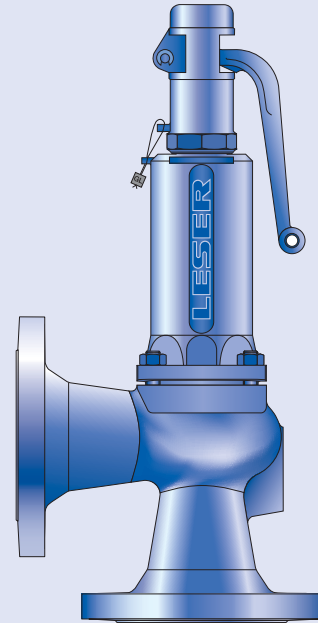

Type 429
Plain lever H3
Closed bonnet
Conventional design

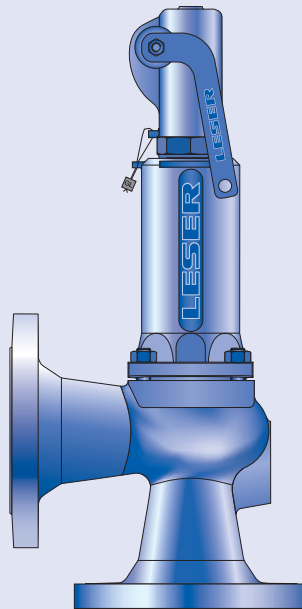

Type 429
Packed lever H4
Closed bonnet
Conventional design

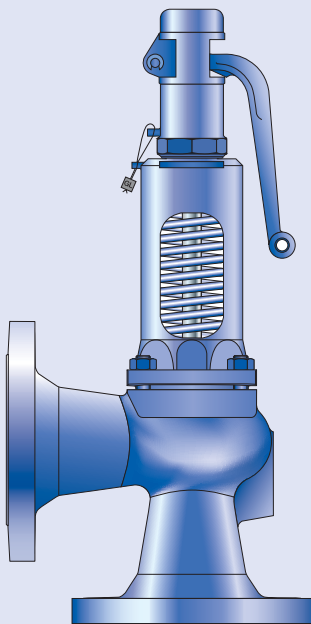

Type 427
Plain lever H3
Open bonnet
Conventional design

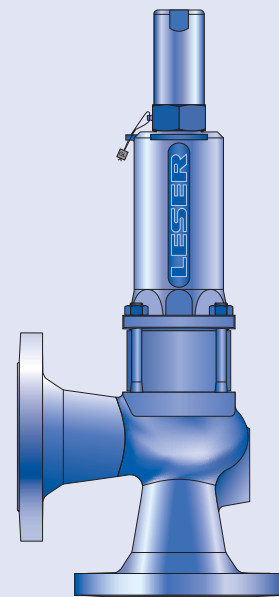

Type 429
Cap H2
Closed bonnet
Balanced bellows design

How to order – Article numbers

Article numbers													
	DN _i		15	20	25	32	40	50	65	80	100	125	150
	DN _o		15	20	25	32	40	50	65	80	100	125	150
	Actual orifice diameter d _o [mm]		12	18	18	18	23	29	37	46	60	74	92
	Actual orifice area A _o [mm ²]		113	254	254	254	416	661	1075	1662	2827	4301	6648
Body material: 0.7043 (Ductile Gr. 60-40-18)													
Bonnet closed	H2	Art.-No. 4295.	8612	8622	8632	8642	8652	8662	8672	8682	8692	-	-
	H3	Art.-No. 4295.	8613	8623	8633	8643	8653	8663	8673	8683	8693	-	-
	H4	Art.-No. 4295.	8614	8624	8634	8644	8654	8664	8674	8684	8694	-	-
open	H3	Art.-No. 4275.	8615	8625	8635	8645	8655	8665	8675	8685	8695	-	-
Body material: 1.0619 (WCB)													
Bonnet closed	H2	Art.-No. 4292.	7122	7132	7142	7152	7162	7172	7182	7192	7202	7212	7222
	H3	Art.-No. 4292.	7123	7133	7143	7153	7163	7173	7183	7193	4203	7213	7223
	H4	Art.-No. 4292.	7124	7134	7144	7154	7164	7174	7184	7194	4204	7214	7224
open	H3	Art.-No. 4272.	7125	7135	7145	7155	7165	7175	7185	7195	4205	7215	7225
Body material: 1.4408 (CF8M)													
Bonnet closed	H2	Art.-No. 4294.	7242	7252	7262	7272	7282	7292	7302	7312	7322	-	-
	H4	Art.-No. 4294.	7244	7254	7264	7274	7284	7294	7304	7314	7324	-	-

Pressure temperature ratings

Metric units													
	DN _i	15	20	25	32	40	50	65	80	100	125	150	
	DN _o	15	20	25	32	40	50	65	80	100	125	150	
	Actual orifice diameter d _o [mm]	12	18	18	18	23	29	37	46	60	74	92	
	Actual orifice area A _o [mm ²]	113	254	254	254	416	661	1075	1662	2827	4301	6648	
Body material: 0.7043 (Ductile Gr. 60-40-18)													
DIN flange	Inlet	PN 16										-	-
	Outlet	PN 16										-	-
Minimum set pressure	p [bar _g] S/G/L	1.5	1.5	1.5	1.5	1.5	1.5	1.5	1.5	1.5	-	-	
Min. set pressure ¹⁾ standard bellows	p [bar _g] S/G/L	3.0	3.0	3.0	3.0	3.0	3.0	3.0	3.0	3.0	-	-	
Min. set pressure low pressure bellows	p [bar _g] S/G/L	-	2.0	2.0	2.0	1.8	1.9	1.8	1.8	1.2	-	-	
Maximum set pressure	p [bar _g] S/G/L	40	40	40	40	40	40	35	35	30	-	-	
Max. set pressure with special spring	p [bar _g] S/G/L	40	40	40	40	40	40	40	35	30	-	-	
Temperature ²⁾ acc. to DIN EN	min. [°C]	-60										-	-
	max. [°C]	+350										-	-

¹⁾ Min. set pressure of standard bellows = max. set pressure of bellows for low set pressure.

²⁾ The temperature is limited by the soft seal material (see page 99/10). The values given here are valid for EPDM. Between -10°C and the lowest specified application temperature, proceed acc. to AD 2000-Merkblatt W10.

Metric units													
	DN _i	15	20	25	32	40	50	65	80	100	125	150	
	DN _o	15	20	25	32	40	50	65	80	100	125	150	
	Actual orifice diameter d _o [mm]	12	18	18	18	23	29	37	46	60	74	92	
	Actual orifice area A _o [mm ²]	113	254	254	254	416	661	1075	1662	2827	4301	6648	
Body material: 1.0619 (WCB)													
DIN flange	Inlet	PN 40										-	-
	Outlet	PN 40										-	-
Minimum set pressure	p [bar _g] S/G/L	1.5	1.5	1.5	1.5	1.5	1.5	1.5	1.5	1.5	1.5	1.5	
Min. set pressure ¹⁾ standard bellows	p [bar _g] S/G/L	3.0	3.0	3.0	3.0	3.0	3.0	3.0	3.0	3.0	3.0	3.0	
Min. set pressure low pressure bellows	p [bar _g] S/G/L	-	2.0	2.0	2.0	1.8	1.9	1.8	1.8	1.2	1.2	on request	
Maximum set pressure	p [bar _g] S/G/L	40	40	40	40	40	40	35	35	30	32	16	
Max. set pressure with special spring	p [bar _g] S/G/L	40	40	40	40	40	40	40	35	30	32	16	
Temperature ²⁾ acc. to DIN EN	min. [°C]	-85										-	-
	max. [°C]	+450										-	-

Pressure temperature ratings

Metric units													
	DN _i	15	20	25	32	40	50	65	80	100	125	150	
	DN _o	15	20	25	32	40	50	65	80	100	125	150	
	Actual orifice diameter d _o [mm]	12	18	18	18	23	29	37	46	60	74	92	
	Actual orifice area A _o [mm ²]	113	254	254	254	416	661	1075	1662	2827	4301	6648	
Body material: 1.4408 (CF8M)													
DIN flange	Inlet											-	-
	Outlet											-	-
Minimum set pressure	p [bar _g] S/G/L	1.5	1.5	1.5	1.5	1.5	1.5	1.5	1.5	1.5	1.5	-	-
	Min. set pressure ¹⁾ standard bellows	p [bar _g] S/G/L	3.0	3.0	3.0	3.0	3.0	3.0	3.0	3.0	3.0	-	-
Min. set pressure low pressure bellows	p [bar _g] S/G/L	-	2.0	2.0	2.0	1.8	1.9	1.8	1.8	1.2	-	-	
	Maximum set pressure	p [bar _g] S/G/L	40	40	40	40	40	31.6	31.0	30	22	-	-
Max. set pressure with special spring	p [bar _g] S/G/L	40	40	40	40	40	40	31	30	22	-	-	
	Temperature ²⁾ acc. to DIN EN	min. [°C]										-270	-
max. [°C]											+400	-	-

¹⁾ Min. set pressure of standard bellows = max. set pressure of bellows for low set pressure.

²⁾ The temperature is limited by the soft seal material (see page 99/10). The values given here are valid for EPDM. Between -10°C and the lowest specified application temperature, proceed acc. to AD 2000-Merkblatt W10.

Dimensions and weights

Metric units												
	DN _i	15	20	25	32	40	50	65	80	100	125	150
	DN _o	15	20	25	32	40	50	65	80	100	125	150
	Actual orifice diameter d _o [mm]	12	18	18	18	23	29	37	46	60	74	92
	Actual orifice area A ₀ [mm ²]	113	254	254	254	416	661	1075	1662	2827	4301	6648
Weight [kg]		5	6	6	8	9	12	15	20	33	48	65
	with bellows	6.3	6.4	6.4	8.4	9.6	13	16	21.6	35.6	52.1	78.4
Centre to face [mm]	Inlet a	90	95	100	105	115	125	145	155	175	200	225
	Outlet b	90	95	100	105	115	125	145	155	175	200	225
Height (H4) [mm]	Standard H max.	310	307	311	320	320	360	476	525	609	743	865
	Bellows H max.	359	337	341	355	355	425	536	595	684	823	960
Support brackets [mm]	A											277
	B											160
(Drilled only on request, option code H42)	C											Ø 18
	D											278
	E											21

Body material: 0.7043 (Ductile Gr. 60-40-18)

DIN flange¹⁾	Inlet	PN 40	-	-
	Outlet	PN 40	-	-

Body material: 1.0619 (WCB)

DIN flange¹⁾	Inlet	PN 40	-	-
	Outlet	PN 40	-	-

Body material: 1.4408 (CF8M)

DIN flange¹⁾	Inlet	PN 40	-	-
	Outlet	PN 40	-	-

¹⁾ Standard flange class For other flange drillings, see page 03/13.

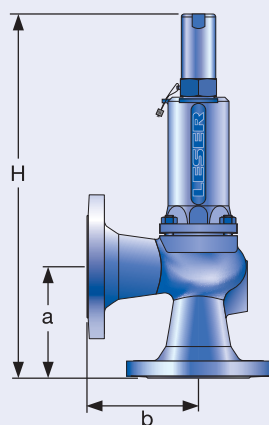

Conventional design

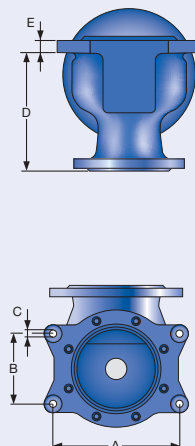

Support brackets

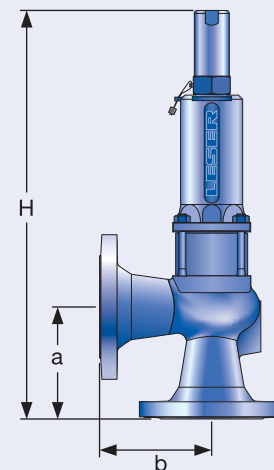

Balanced bellows design

Flange drillings

Flange drillings													
	DN _i	15	20	25	32	40	50	65	80	100	125	150	
	DN _o	15	20	25	32	40	50	65	80	100	125	150	
	Valve size	1/2" x 1/2"	3/4" x 3/4"	1" x 1"	1 1/4" x 1 1/4"	1 1/2" x 1 1/2"	2" x 2"	2 1/2" x 2 1/2"	3" x 3"	4" x 4"	5" x 5"	6" x 6"	
	Actual orifice diameter d ₀ [mm]	12	18	18	18	23	29	37	46	60	74	92	
	Actual orifice area A ₀ [mm ²]	113	254	254	254	416	661	1075	1662	2827	4301	6648	
Body material: 0.7043 (Ductile Gr. 60-40-18), 1.0619 (WCB), 1.4408 (CF8M)													
Inlet	DIN EN 1092	PN 10	*	*	*	*	*	*	H44	H44	H44	H44	H44
		PN 16	*	*	*	*	*	*	H45	H45	H45	H45	H45
		PN 25	*	*	*	*	*	*	*	*	*	*	*
		PN 40	*	*	*	*	*	*	*	*	*	*	*
	ASME B16.5 ¹⁾	CL150	H64	H64	H64	H64	H64	H64	H64	H64	[H64]	H64	H64
		CL300	[H65]	–	H65	H65	–	[H65]	[H65]	–	–	–	–
Outlet	DIN EN 1092	PN 10	*	*	*	*	*	*	H50	H50	H50	H50	H50
		PN 16	*	*	*	*	*	*	H51	H51	H51	H51	H51
		PN 25	*	*	*	*	*	*	*	*	*	*	*
		PN 40	*	*	*	*	*	*	*	*	*	*	*
	ASME B16.5 ¹⁾	CL150	H79	H79	H79	H79	H79	H79	H79	H79	[H79]	H79	H79
		CL300	H80	–	H80	H80	–	[H80]	[H80]	–	–	–	–

Flange facings											
Information	Standard	Inlet		Outlet		Remark					
General											
Flange, undrilled	–	H38		H39							
Linde-V-Nut, Form V48	Linde Standard 420-08	J07		J08		Groove: Rz = 16					
Linde-V-Nut, Form V48A	LWN 313.36	J05		J06		Groove: Rz = 4, e.g. for hydrogen					
Lens-shape seal form L (without lens-shape seal)	DIN 2696 LWN 313.35	J11		J12							
According to DIN EN 1092											
Flange facings		Inlet		Outlet		Remark					
DIN EN 1092 (also see LWN 313.40)		PN 10 – PN 40		PN 10 – PN 40		Rz specification acc. to DIN EN 1092 in µm					
Sealing strip	Form B1	*		*		Seal. strip.: Rz = 12.5 – 50					
	Form B2	L36		L38		Seal. strip.: Rz = 3.2 – 12.5					
Tongue, Form C ¹⁾		H94		H92		only for steel flange					
Groove, Form D ¹⁾		H93		H91							
Male, Form E		H96		H98							
Female, Form F		H97		H99							
O-ring Male, Form G		J01		J02							
O-ring Female, Form H		J03		J04							
According to ASME B16.5											
Body material	Inlet	Outlet	Smooth Finish ²⁾		Serrated Finish		RTJ-Groove				
			Inlet	Outlet	Inlet	Outlet	Inlet		Outlet		
			Option code		Option code		Pressure level	Option code	Pressure level	Option code	
0.7043, 1.0619, 1.4408	all	all	L52	L53	*	*	–	–	–	–	

¹⁾ LESER manufactures the groove at flanged valves by milling. If a customer demands a turned surface in the soil of the groove according to DIN EN 1092-1 an additional option code is necessary: "S01: soil of the groove drilled".

²⁾ Smooth finish is not defined in the effective standards.

For an explanation of signs and symbols, refer to page 00/07.

Note: Flange drillings and facings always meet the requirements of mentioned flange standards.
Flange thickness and outer diameter may deviate from flange standard.

Order information – Spare parts

Spare parts							
	DN _i	15	20	25	32	40	50
	DN _o	15	20	25	32	40	50
	Actual orifice diameter d ₀ [mm]	12	18	18	18	23	29
	Actual orifice area A ₀ [mm ²]	113	254	254	254	416	661
Disc (item 7): Metal seat				Material-No. / Art.-No.			
Disc	1.4122	212.3439.9000	211.0139.9000	211.0139.9000	211.0139.9000	211.0239.9000	211.0339.9000
Detachable lifting aid	1.4404	212.3449.9000	211.0149.9000	211.0149.9000	211.0149.9000	211.0249.9000	211.0349.9000
Disc (item 7): Soft seal				Material-No. / Art.-No.			
Disc	CR	“K”	–	200.6849.9051	200.6849.9051	200.6849.9051	200.7049.9051
	EPDM	“D”	–	200.6849.9041	200.6849.9051	200.6849.9041	200.6849.9051
	FKM	“L”	–	200.6849.9071	200.6849.9051	200.6849.9071	200.6849.9051
	FFKM	“C”	–	200.6849.9091	200.6849.9051	200.6849.9091	200.6849.9051
O-ring (item 7.4): Soft seal				Material-No. / Art.-No.			
O-ring	CR	“K”	–	502.0171.2651	502.0171.2651	502.0171.2651	502.0249.3551
	EPDM	“D”	–	502.0171.2641	502.0171.2641	502.0171.2641	502.0249.3541
	FKM	“L”	–	502.0171.2671	502.0171.2671	502.0171.2671	502.0249.3571
	FFKM	“C”	–	502.0171.2691	502.0171.2691	502.0171.2691	502.0249.3591
Bellows (item 15): 1.4571				Material-No. / Art.-No.			
Standard bellows		400.0149.0000	400.0149.0000	400.0149.0000	400.0149.0000	400.0249.0000	400.0349.0000
Conversion kit, standard¹⁾		5021.1030	5021.1034	5021.1034	5021.1034	5021.1035	5021.1036
Low pressure bellows		–	400.0149.0021	400.0149.0021	400.0149.0021	400.0249.0021	400.0349.0021
Conversion kit low pressure¹⁾				Please specify application conditions			
Gasket – body / bonnet (item 60)				Material-No. / Art.-No.			
Gasket	Graphite + 1.4401	500.0407.0000	500.0407.0000	500.0407.0000	500.0407.0000	500.0407.0000	500.0507.0000
Option code L68 Gylon (PTFE compliance)		500.0405.0000	500.0405.0000	500.0405.0000	500.0405.0000	500.0405.0000	500.0505.0000
Ball (item 61):				Material-No. / Art.-No.			
Ball	Ball Ø [mm]	6	6	6	6	6	6
	1.4404	510.0104.0000	510.0104.0000	510.0104.0000	510.0104.0000	510.0104.0000	510.0104.0000
Split ring (item 14):				Material-No. / Art.-No.			
Split ring	Spindle Ø [mm]	12	12	12	12	12	12
	1.4404	251.0149.0000	251.0149.0000	251.0149.0000	251.0149.0000	251.0149.0000	251.0149.0000
Pin (item 57)				Material-No. / Art.-No.			
Pin	1.4310	480.0505.0000	480.0505.0000	480.0505.0000	480.0505.0000	480.0505.0000	480.0705.0000
O-ring damper				Material-No. / Art.-No.			
	Conversion kit H2	5021.1060	–	5021.1060	5021.1060	5021.1060	5021.1060
	Conversion kit H4	5021.1064	–	5021.1064	5021.1064	5021.1064	5021.1064

¹⁾ Pressure range, see page 03/10 – 03/11

A conversion kit includes the following components:

Item.	Components	No.
8	Guide with bushing	1
11	Bonnet spacer	1
12	Spindle	1
15	Bellows	1
55	Stud	4, 8 dependant on valve size
60	Gasket	2, 3 dependant on valve size
	Installation instruction LWN 037.05	1

Refer to page 03/04

Order information – Spare parts

Spare parts						
	DN _i	65	80	100	125	150
	DN _o	65	80	100	125	150
	Actual orifice diameter d ₀ [mm]	37	46	60	74	92
	Actual orifice area A ₀ [mm ²]	1075	1662	2827	4301	6648
Disc (item 7): Metal seat						
Material-No. / Art.-No.						
Disc	1.4122	211.0439.9000	211.0639.9000	212.0539.9000	212.0639.9000	211.1239.9000
Detachable lifting aid	1.4404	211.0449.9000	211.0649.9000	212.0549.9000	212.0649.9000	212.0749.9000
Disc (item 7): Soft seal						
Material-No. / Art.-No.						
Disc	CR	"K"	200.7149.9051	200.7249.9051	200.7349.9051	200.7449.9051 on request
	EPDM	"D"	200.7149.9041	200.7249.9041	200.7349.9041	200.7449.9041 on request
	FKM	"L"	200.7149.9071	200.7249.9071	200.7349.9071	200.7449.9071 200.7549.9071
	FFKM	"C"	200.7149.9091	200.7249.9091	on request	on request on request
O-ring (item 7.4): Soft seal						
Material-No. / Art.-No.						
O-ring	CR	"K"	502.0408.3551	502.0503.3551	502.0660.5351	502.0819.5351 on request
	EPDM	"D"	502.0408.3541	502.0503.3541	502.0660.5341	502.0819.5341 on request
	FKM	"L"	502.0408.3571	502.0503.3571	502.0660.5371	502.0819.5371 502.1041.5371
	FFKM	"C"	502.0408.3591	502.0503.3591	on request	on request on request
Bellows (item 15): 1.4571						
Material-No. / Art.-No.						
Standard bellows		400.0449.0000	400.0549.0000	400.0649.0000	400.0749.0000	400.0849.0000
Conversion kit, standard¹⁾		5021.1037	5021.1038	5021.1039	Component parts	Component parts
Low pressure bellows		400.0449.0021	400.0549.0021	400.0649.0021	400.1107	400.0849.0021
Conversion kit low pressure¹⁾		Please specify application conditions			-	-
Gasket – body / bonnet (item 60)						
Material-No. / Art.-No.						
Gasket	Graphite + 1.4401	500.0907.0000	500.1007.0000	500.1507.0000	500.1807.0000	500.2107.0000
Option code L68 Gylon (PTFE compliance)		500.0905.0000	500.1005.0000	500.1505.0000	500.1805.0000	500.2105.0000
Ball (item 61):						
Material-No. / Art.-No.						
Ball	Ball Ø [mm]	9	9	12	12	15
	1.4404	510.0204.0000	510.0204.0000	510.0304.0000	510.0304.0000	510.0404.0000
Split ring (item 14):						
Material-No. / Art.-No.						
Split ring	Spindle Ø [mm]	16	16	16	20	24
	1.4404	251.0249.0000	251.0249.0000	251.0249.0000	251.0349.0000	251.0449.0000
Pin (item 57)						
Material-No. / Art.-No.						
Pin	1.4310	480.0705.0000	480.0705.0000	480.1005.0000	480.1005.0000	480.1105.0000
O-ring damper						
Material-No. / Art.-No.						
	Conversion kit H2	5021.1061	5021.1061	-	-	-
	Conversion kit H4	5021.1065	5021.1065	-	-	-

¹⁾ Pressure range, see page 03/10 – 03/11

One bellows conversion set includes the following components:

Item.	Components	No.
8	Guide with bushing	1
11	Bonnet spacer	1
12	Spindle	1
15	Bellows	1
55	Stud	4, 8 dependant on valve size
60	Gasket	2, 3 dependant on valve size
	Installation instruction LWN 037.05	1

Refer to page 03/04

Available options

For more information, also see
"Accessories and options" as of page 99/01.

Heating jacket

H29, H30: Coupling G 3/8, G 3/4
H31, H32: Flange DN15, DN25

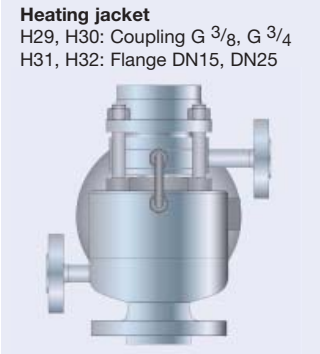

Drain hole

J18: G 1/4
J19: G 1/2

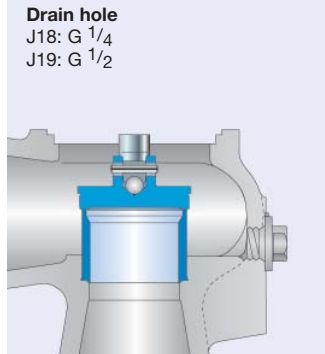

Open bonnet

See Art.-No.



O-ring disc

J20: FFKM "C"
J21: CR "K"
J22: EPDM "D"
J23: FKM "L"

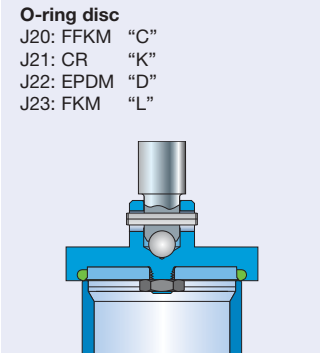

Balanced bellows

J68: Open bonnet
J78: Closed bonnet

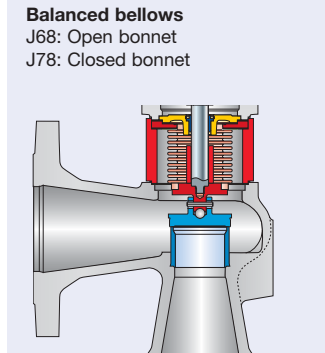

Conversion set for balanced bellows

Art.-No. see page 02/14

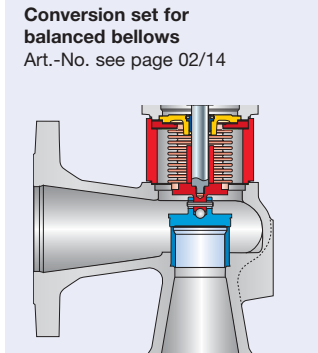

Screwed cap H2

H2



Plain lever H3

H3



Packed lever H4

H4



O-ring damper H2

J65

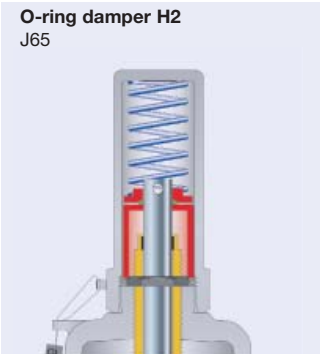

O-ring damper H4

J66



Lift indicator

J39: Adaptor H4
J93: Lift indicator

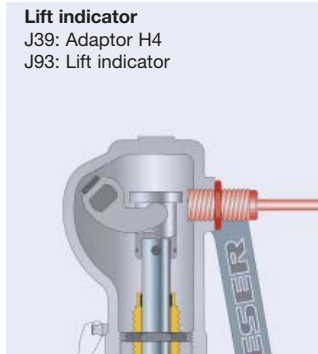

Test gag

J69: H4
J70: H4

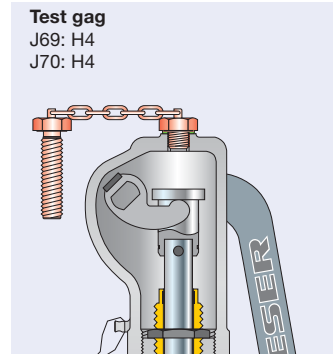

Approvals

Approvals		
	DN _E	15 – 150
	DN _A	15 – 150
	Actual orifice diameter d ₀ [mm]	12 – 92
	Actual orifice area A ₀ [mm ²]	113 – 6648
Europa		Coefficient of discharge K_{dr}
PED / DIN EN ISO 4126-1	Approval-No.	072020111Z0008/0/04
	S/G	0.13
	L	The valve is component tested for liquids with thermal expansion.
Germany		Coefficient of discharge α_w
PED / AD 2000-Merkblatt A2 Proportional safety valve	Approval-No.	TÜV SV 610
	S/G	0.13
	L	The valve is component tested for liquids with thermal expansion.
China		Coefficient of discharge α_w
AQSIQ	Approval-No.	For current Approval-No. see www.leser.com
	S/G	0.13
	L	The valve is component tested for liquids with thermal expansion.
Belarus		Coefficient of discharge α_w
GOSPROMNAZADOR	Approval-No.	For current Approval-No. see www.leser.com
	S/G	0.13
	L	The valve is component tested for liquids with thermal expansion.
Classification societies		
on request		

Information:

According to AD 2000-Merkblatt A2 Chap. 10.3, the discharge coefficient "... for normal or proportional safety valves, should not exceed the value $\alpha_w = 0.08$ for S/G or the value $\alpha_w = 0.05$ for L." Since the actual α_w value for liquids is below the requirements of the AD 2000-Merkblatt for the Series 429, it is not possible to accord a discharge coefficient α_w .

Capacities – Steam

Calculation of the capacity for saturated steam acc. to AD 2000-Merkblatt A2 with 10% overpressure.
Capacities at 1 bar and lower are calculated at 0.1 bar overpressure.

Metric units		AD 2000-Merkblatt A2 [kg/h]										
DN _i		15	20	25	32	40	50	65	80	100	125	150
DN _o		15	20	25	32	40	50	65	80	100	125	150
Actual orifice diameter d _o [mm]		12	18	18	18	23	29	37	46	60	74	92
Actual orifice area A _o [mm ²]		113	254	254	254	416	661	1075	1662	2827	4301	6648
LEO _{S/G} ^{*)} [inch ²]		0.023	0.053	0.053	0.053	0.086	0.137	0.222	0.343	0.584	0.889	1.374
Set pressure [bar]		Capacity [kg/h]										
1.5		22	50	50	50	81	130	211	326	555	843	1304
2		27	60	60	60	98	155	253	391	665	1012	1564
3		35	79	79	79	130	206	336	519	883	1343	2076
4		44	99	99	99	162	257	419	647	1101	1675	2589
5		53	119	119	119	194	308	501	775	1318	2005	3099
6		61	138	138	138	225	358	584	902	1534	2334	3608
7		70	157	157	157	256	408	664	1026	1746	2655	4104
8		78	176	176	176	288	458	746	1152	1960	2982	4609
9		87	196	196	196	320	508	827	1278	2175	3308	5114
10		96	215	215	215	351	558	909	1404	2389	3635	5618
12		113	254	254	254	414	658	1072	1656	2818	4286	6625
14		130	291	291	291	476	756	1231	1903	3238	4925	7612
16		147	330	330	330	539	856	1394	2154	3665	5575	8617
18		164	368	368	368	601	956	1557	2406	4093	6226	
20		181	407	407	407	665	1056	1720	2658	4522	6879	
22		198	444	444	444	726	1154	1878	2903	4938	7511	
24		215	483	483	483	789	1254	2041	3155	5368	8165	
26		232	522	522	522	852	1355	2205	3408	5798	8820	
28		249	561	561	561	915	1455	2369	3662	6230	9477	
30		267	600	600	600	979	1557	2534	3917	6663	10136	
32		284	639	639	639	1043	1658	2699	4172		10797	
34												
36												
38												
40												

^{*)} LEO S/G = LESER Effective Orifice steam/gases please refer to page 00/11
"How to use" capacity tables, refer to page 00/09

Capacities – Air

Calculation of the capacity for air acc. to AD 2000-Merkblatt A2 with 10% overpressure at 0 °C and 1013 mbar.
Capacities at 1 bar and below are calculated with 0.1 bar overpressure.

Metric units		AD 2000-Merkblatt A2 [m _n ³ /h]										
DN _i		15	20	25	32	40	50	65	80	100	125	150
DN _o		15	20	25	32	40	50	65	80	100	125	150
Actual orifice diameter d _o [mm]		12	18	18	18	23	29	37	46	60	74	92
Actual orifice area A _o [mm ²]		113	254	254	254	416	661	1075	1662	2827	4301	6648
LEO _{S/G} ^{*)} [inch ²]		0.023	0.053	0.053	0.053	0.086	0.137	0.222	0.343	0.584	0.889	1.374
Set pressure [bar]	Capacity [m _n ³ /h]											
1.5		27	60	60	60	98	156	253	391	666	1013	1565
2		32	72	72	72	118	188	306	472	803	1222	1889
3		43	97	97	97	159	252	410	634	1079	1641	2536
4		54	122	122	122	199	316	515	796	1354	2060	3184
5		65	147	147	147	239	381	620	958	1629	2479	3831
6		76	171	171	171	280	445	724	1120	1905	2897	4478
7		87	196	196	196	320	509	829	1281	2180	3316	5126
8		98	221	221	221	361	574	934	1443	2455	3735	5773
9		109	246	246	246	401	638	1038	1605	2731	4154	6420
10		120	271	271	271	442	702	1143	1767	3006	4573	7068
12		142	320	320	320	523	831	1353	2091	3557	5410	8362
14		164	370	370	370	604	960	1562	2414	4107	6248	9657
16		186	419	419	419	684	1088	1771	2738	4658	7086	10952
18		208	469	469	469	765	1217	1981	3062	5209	7923	
20		230	518	518	518	846	1345	2190	3385	5759	8761	
22		252	568	568	568	927	1474	2400	3709	6310	9598	
24		274	617	617	617	1008	1603	2609	4033	6861	10436	
26		296	667	667	667	1089	1731	2818	4356	7411	11274	
28		318	717	717	717	1170	1860	3028	4680	7962	12111	
30		341	766	766	766	1251	1989	3237	5004	8513	12949	
32		363	816	816	816	1332	2117	3447	5327		13786	
34		385	865	865	865	1413	2246	3656	5651			
36		407	915	915	915	1494	2375	3865				
38		429	964	964	964	1575	2503	4075				
40		451	1014	1014	1014	1655	2632	4284				

*) LEO S/G = LESER Effective Orifice steam/gases please refer to page 00/11
"How to use" capacity tables, refer to page 00/09

Capacities – water

Acc. to AD 2000-Merkblatt A2, the LESER safety valve type 427, 429 can be used for thermal expansion in spite of having no component testing for liquids. To calculate the water capacity table, a coefficient of discharge of $\alpha_w = 0.05$ was used.

Calculation of the capacity for water as per AD 2000-Merkblatt A2 with 10% overpressure at 20 °C.
Capacities at 1 bar and below are calculated with 0.1 bar overpressure.

Metric units		AD 2000-Merkblatt A2 [10^3kg/h]										
DN		15	20	25	32	40	50	65	80	100	125	150
DN _o		15	20	25	32	40	50	65	80	100	125	150
Actual orifice diameter d _o [mm]		12	18	18	18	23	29	37	46	60	74	92
Actual orifice area A _o [mm ²]		113	254	254	254	416	661	1075	1662	2827	4301	6648
LEO _L ^{*)} [inch ²]		0.009	0.020	0.020	0.020	0.033	0.053	0.085	0.132	0.225	0.342	0.528
Set pressure [bar]		Capacity [10^3kg/h]										
1.5		0.30	0.67	0.67	0.67	1.09	1.73	2.81	4.34	7.39	11.2	17.4
2		0.34	0.77	0.77	0.77	1.25	1.99	3.24	5.02	8.53	13.0	20.1
3		0.42	0.94	0.94	0.94	1.54	2.44	3.97	6.14	10.4	15.9	24.6
4		0.48	1.09	1.09	1.09	1.77	2.82	4.59	7.09	12.1	18.4	28.4
5		0.54	1.21	1.21	1.21	1.98	3.15	5.13	7.93	13.5	20.5	31.7
6		0.59	1.33	1.33	1.33	2.17	3.45	5.62	8.69	14.8	22.5	34.7
7		0.64	1.44	1.44	1.44	2.35	3.73	6.07	9.38	16.0	24.3	37.5
8		0.68	1.54	1.54	1.54	2.51	3.99	6.49	10.0	17.1	26.0	40.1
9		0.72	1.63	1.63	1.63	2.66	4.23	6.88	10.6	18.1	27.5	42.6
10		0.76	1.72	1.72	1.72	2.80	4.46	7.26	11.2	19.1	29.0	44.9
12		0.84	1.88	1.88	1.88	3.07	4.88	7.95	12.3	20.9	31.8	49.1
14		0.90	2.03	2.03	2.03	3.32	5.27	8.58	13.3	22.6	34.3	53.1
16		0.97	2.17	2.17	2.17	3.55	5.64	9.18	14.2	24.1	36.7	56.7
18		1.02	2.30	2.30	2.30	3.76	5.98	9.73	15.0	25.6	38.9	
20		1.08	2.43	2.43	2.43	3.96	6.30	10.3	15.9	27.0	41.0	
22		1.13	2.55	2.55	2.55	4.16	6.61	10.8	16.6	28.3	43.0	
24		1.18	2.66	2.66	2.66	4.34	6.90	11.2	17.4	29.6	45.0	
26		1.23	2.77	2.77	2.77	4.52	7.19	11.7	18.1	30.8	46.8	
28		1.28	2.87	2.87	2.87	4.69	7.46	12.1	18.8	31.9	48.6	
30		1.32	2.97	2.97	2.97	4.86	7.72	12.6	19.4	33.0	50.3	
32		1.37	3.07	3.07	3.07	5.02	7.97	13.0	20.1		51.9	
34		1.41	3.17	3.17	3.17	5.17	8.22	13.4	20.7			
36		1.45	3.26	3.26	3.26	5.32	8.46	13.8				
38		1.49	3.35	3.35	3.35	5.47	8.69	14.1				
40		1.53	3.43	3.43	3.43	5.61	8.91	14.5				

*) LEO_L = LESER Effective Orifice liquids please refer to page 00/11

"How to use" capacity tables, refer to page 00/09

Accessories and Options

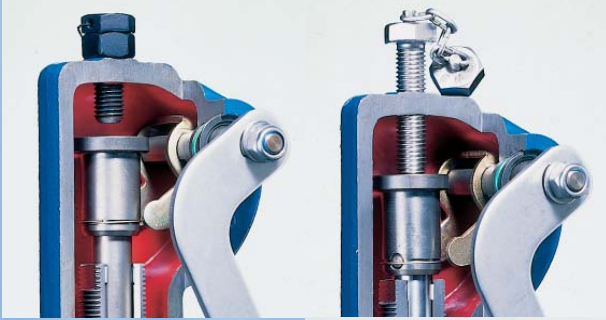
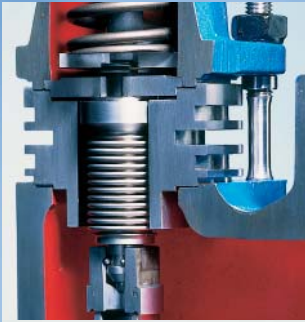

Contents

Chapter/Page

Overview	99/02
Caps and levers	99/04
Metal seat	99/06
Disc with soft seal	99/08
Soft seal disc	99/10
Disc	99/11
Balanced bellows	99/12
Heating jacket	99/14
O-ring damper	99/16
Elastomer bellows	99/18
Lift indicator	99/19
Lift stoppers	99/20

Overview

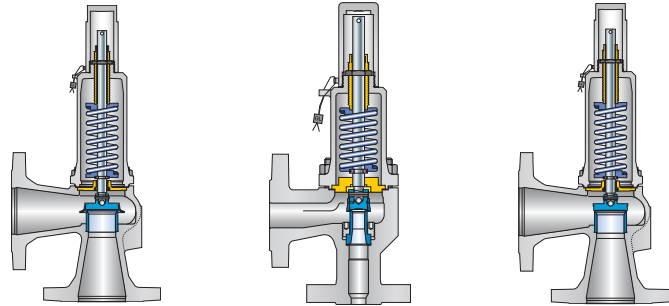

Options		Type	Option code	431, 433	431, 433 PN 160	427, 429
Disc (item 7):						
		Disc with detachable lifting aid	J26	✓	*	*
		Bull race disc	J24	✓	✓	✓
Seal type (item 5 and 7)						
Metal seat		Disc 1.4404	L44	✓	✓	✓
		Disc 1.4404 stellite	J25	✓	✓	✓
Soft seal	O-Ring	CR "K"	J21	✓	✓	✓
		NBR "N"	J30	✓	✓	✓
		EPDM "D"	J22	✓	✓	✓
		FKM "L"	J23	✓	✓	✓
		FFKM "C"	J20	✓	✓	✓
Sealing plate		SP "T"	J49	✓	on request	–
		PCTFE "G"	J48	✓	on request	–
		PTFE "A"	J44	✓	on request	–
Bellows (item 15, item 70)						
Open bonnet		Standard bellows	J68	✓	✓	✓
		Low pressure bellows	J68J63	✓	–	✓
Bonnet closed		Standard bellows	J78	✓	✓	✓
		Low pressure bellows	J78J63	✓	–	✓
		Other materials	J25 + Material name	✓	✓	✓
Elastomer bellows		EPDM	J79	✓	–	✓
		NBR	J87	✓	–	✓
Caps and levers (item 40)						
		H2		✓	✓	✓
		H3		✓	✓	✓
		H4		✓	✓	✓
Spring (item 54)						
		High temperature alloy 1.8159 / 1.7102	X01	✓	✓	✓
		Stainless steel 1.4310	X04	✓	✓	✓

Overview

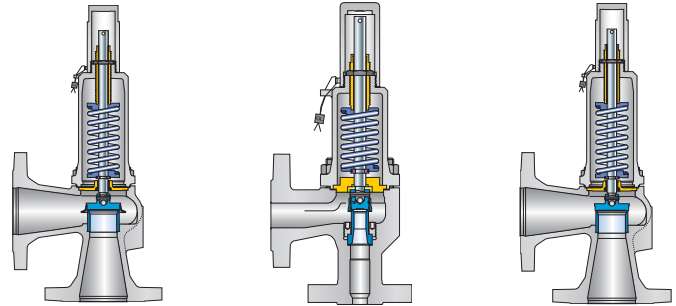

Options		Type	Option code	431, 433	431, 433 PN 160	427, 429
Test gag						
	H2		J70	✓	✓	✓
	H4		J69	✓	✓	✓
Bonnet (item 9)						
	closed			✓	✓	✓
	open			✓	✓	✓
Heating jacket						
				✓	✓	✓
Lift indicator						
	Lifting device H2, H4		J39J93	✓	✓	✓
Lift stoppers						
	Bush		J51	✓	✓	✓
	Gag H2		J52	✓	✓	✓
	Gag H4		J50	✓	✓	✓
Drain hole						
	G 1/4		J18	✓	✓	✓
	G 1/2		J19	✓	✓	✓
O-ring damper (item 40)						
	H2		H65	✓	✓	✓
	H4		H66	✓	✓	✓
Bursting disc						
	H2			✓	✓	✓

Caps and levers – subassembly item 40

Cap H2

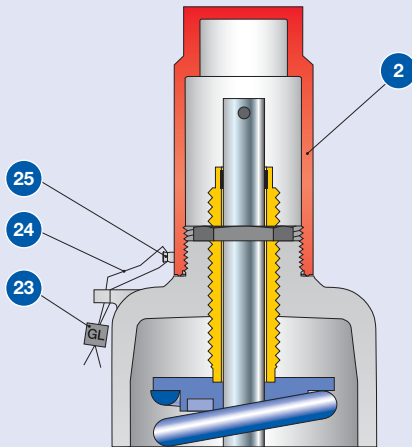

Packed lever H4

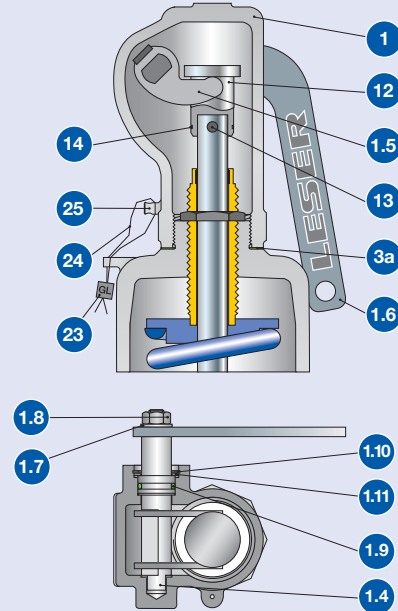

Plain lever H3

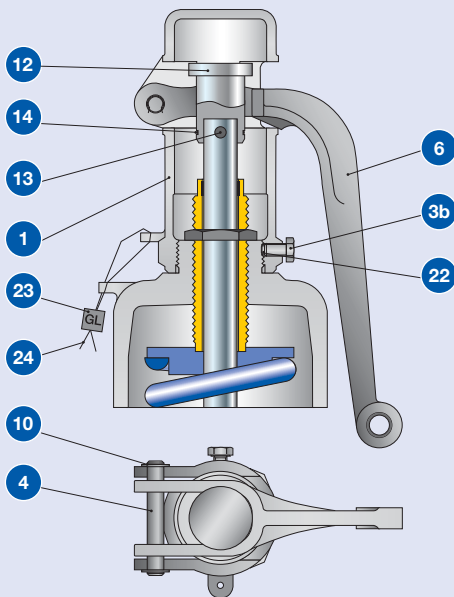

Test gag

Cap H2: J70
Packed lever H4: J69

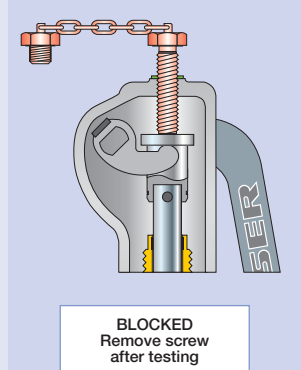
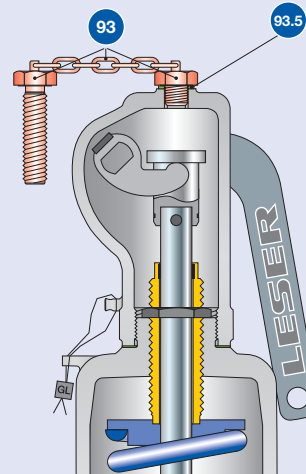

Test gag

The test gag prevents the spindle from lifting and keeps the safety valve tight while the system pressure exceeds the set pressure.

The test gag is used to:

- perform the pressure test in a system without disassembling the safety valve
- be able to make an adjustment to each individual valve in systems with multiple safety valves

The test gag must be removed after testing, otherwise the safety valve will not protect the system against impermissible overpressure.

Caps and levers – subassembly item 40

Materials		Steel			Stainless steel	
Item.	Component	Cap H2	Plain lever H3	Packed lever H4	Cap H2	Packed lever H4
1	Lever cover	–	0.7040	0.7040	–	1.4408
		–	Gr. 60-40-18	Gr. 60-40-18	–	CF8M
2	Cap	1.0718	–	–	1.4404	–
		Steel	–	–	316L	–
3a	Spacer	–	–	1.4571	–	1.4571
		–	–	316Ti	–	316Ti
3b	Hex screw	–	1.4401	–	–	–
		–	B8M	–	–	–
4 / 1.4	Shaft / bolt	–	1.4021	1.0718	–	1.4404
		–	420	Steel	–	316L
1.5	Lifting fork	–	–	1.0531	–	1.4571
		–	–	Steel	–	316Ti
6 / 1.6	Lever	–	0.7040	1.0036	–	1.4301
		–	Gr. 60-40-18	Steel	–	304
1.7	Washer	–	–	1.4401	–	1.4301
		–	–	316	–	304
1.8	Nut	–	–	A2/Poly	–	1.4401
		–	–	2H	–	8M
1.9	O-Ring	–	–	FKM	–	–
		–	–	FKM	–	–
1.9	Packing ring precast	–	–	–	–	Graphite
		–	–	–	–	Graphite
10/1.10	Retaining clip	–	Carbon steel	Carbon steel	–	–
		–	Carbon steel	Carbon steel	–	–
1.10	Nut	–	–	–	–	1.4104
		–	–	–	–	Chrome steel
1.10	Packing gland	–	–	–	–	1.4404
		–	–	–	–	316L
1.11	Support ring	–	–	Carbon steel	–	–
		–	–	Carbon steel	–	–
12	Spindle cap	–	1.0718	1.0718	–	1.4404
		–	Carbon steel	Carbon steel	–	316L
13	Pin	–	Steel	Steel	–	1.4401
		–	Steel	Steel	–	8M
14	Securing ring	–	1.4571	1.4571	–	1.4571
		–	316Ti	316Ti	–	316Ti
22	Plug	–	Plastic	–	–	–
		–	Plastic	–	–	–
23	Seal	Plastic	Plastic	Plastic	Plastic	Plastic
		Plastic	Plastic	Plastic	Plastic	Plastic
24	Seal wire	1.4541	1.4541	1.4541	1.4541	1.4541
		321	321	321	321	321
25	Sealing nose	1.4435	–	–	1.4435	1.4435
		316L	–	–	316L	316L
93	Test gag	1.4401	–	1.4401	1.4401	1.4401
		B8M	–	B8M	B8M	B8M
93.5	Washer	Fiber	–	Fiber	Fiber	Fiber
		Fiber	–	Fiber	Fiber	Fiber

Note:

- LESER reserves the right to make changes
- LESER may use higher quality materials without giving prior information
- Each component can be constructed of another material according to the customer's specification.

Metal seat – seat / nozzle, item 5 and disc subassembly item 7

With LESER, the metal seat surfaces (disc and seat) are optically lapped planar to guarantee high seal tightness. LESER safety valves are delivered with a standard seal tightness acc. to API 527.

Improved tightness (Option code J86) is available on request.

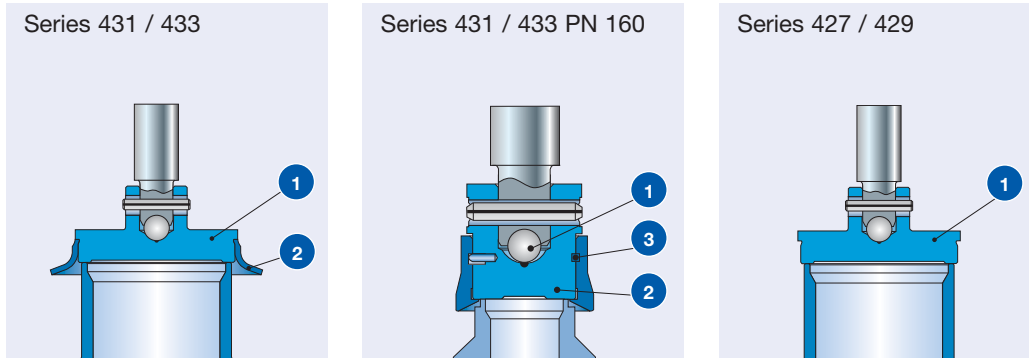

Stellited sealing surface

The sealing surfaces of stainless steel discs and seats / nozzles can be stellited by weld cladding. Stellite is a cobalt-chrome non-ferrous alloy with increased hardness, corrosion resistance, and abrasion resistance even at high temperatures.

LESER recommends stellited sealing surfaces for Modulate Action safety valves (seat / nozzle and disc (1.4404 / 316L)) in the following applications:

- for high-pressure applications with highly stressed sealing surfaces
- for high-temperature applications in order to prevent permanent deformation of the sealing surface as a consequence of the material properties of the seat and disc
- use with abrasive media in order to increase the abrasion resistance of the sealing surface

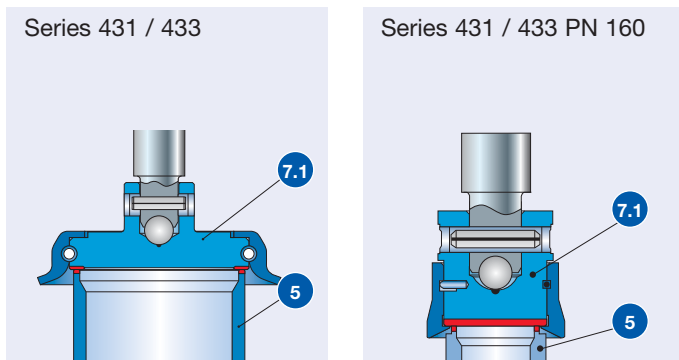

Materials for disc and seat / nozzle, see page 99/09.

Hardness		Metal seat		
Material		Hardness of the sealing surface		
EN	ASME	Value according to standard or manufacturer specification		Mean value LESER bearing material
EN 10088-3, 1.4122 hardened	Chrome steel, hardened	≥ 40 HRC	LWN 325.01 hardening process	42 – 46 HRC
EN 10272, 1.4404	SA 479 316L	≤ 215 HBW	EN 10272 Table 7	16 – 19 HRC ¹⁾
EN 10272, 1.4404 stellited	SA 479 316L stellited	≥ 35 HRC	Manufacturer specification	40 HRC

HBW: BRINELL hardness acc. to DIN EN ISO 6506-1 / HRC: ROCKWELL hardness acc. to DIN EN ISO 6508-1

¹⁾ Rockwell hardnesses less than 20 HRC are not approved by the standard. LESER gives these values for better comparability.

Metal seat – seat / nozzle, item 5 and disc subassembly item 7

Standard and corrosiv service

Materials		Disc – subassembly item 7	
Item	Component	Steel	Stainless steel
Type 431 / 433			
1	Disc	1.4122 hardened	1.4404
		Hardened stainless steel	316L
2	Lifting aid	1.4404	1.4404
		316L	316L
Type 431 / 433 PN 160			
1	Disc	1.4122 hardened	1.4404
		Hardened stainless steel	316L
2	Lifting aid	1.4104	1.4404
		Chrome steel	316L
3	Circlip	1.4571	1.4571
		316Ti	316Ti
Series 427 / 429			
1	Disc	1.4122 hardened	1.4404
		Hardened stainless steel	316L

Materials		Seat / nozzle item 5	
Item	Component	Steel	Stainless steel
All series			
5	Seat / nozzle		1.4404

Stellited sealing surface

Materials		Seat / nozzle item 5, disc item 7	
Item	Component	Option code	
Type 431 / 433, 431 / 433 PN 160			
7.1	Disc	J25	1.4404 stellited
			316L stellited
5	Seat / nozzle	L61 / L62	1.4404 stellited
			316L stellited

Disc with soft seal – subassembly item 7

LESER soft seals provide increased seal tightness for your application.

Construction features

- Different constructions for an expanded range of applications
- Large selection of soft seal materials for almost any application, and custom made for the respective customer requirement
- The increased service life of the seal compared to metal seats reduces the service costs.
- An easier and faster replacement of the soft seal reduces service costs.
- Standard ARP O-ring dimensions facilitate easy worldwide procurement.
- A standard hardness for each O-ring material for all set pressures simplifies the stocking of spare parts and reduces warehousing costs.

Design of soft seal			O-ring disc					
Type			431 / 433		433 PN 160		427 / 429	
Nominal size			DN 15		DN 15		DN 20 – DN 150	
Pressure range			0.3 – 40 bar		0.2 – 160 bar		1.5 – 40 bar	
Option code								
CR	“K”	J21						
EPDM	“D”	J22						
FKM	“L”	J23						
FFKM	“C”	J20						

For temperature application limits, media resistance, and option codes, see selection table on page 99/10.
Materials for soft sealing disc, see page 99/09

Materials		Disc – subassembly item 7							
Type		431 / 433		433 PN 160		427 / 429			
		DN 15		DN 15		DN 20 – DN 150			
		0.3 – 40 bar		0.2 – 160 bar		1.5 – 40 bar			
Disc	Item 7.1	1.4404 316L		Item 7.1	1.4404 316L		Item 7.1	1.4404 316L	
Retainer	Item 7.3	1.4404 316L		–		Item 7.3	1.4404 316L		
Soft seal Materials, see page 99/10	Item 7.4	O-ring		Item 7.5	O-ring		Item 7.4	O-ring	
Lifting aid		see Item 7.1		Item 7.2	1.4404 316L		–		
Nut	Item 7.5	1.4401 8M		–		Item 7.5	1.4401 8M		

For temperature application limits, media resistance and option codes, see selection table on page 04/08.

Soft seal disc – subassembly item 7

Construction		Disc with sealing plate		
Type		431 / 433	433 PN 160	427 / 429
Option code		Pressure range		
SP: "T"	J49	10 – 40 bar	–	–
PCTFE: "G"	J48	1.0 – 30 bar	–	–
PTFE: "A"	J44	1.0 – 10 bar	–	–
Design				On request
				Not available

Materials		Disc – subassembly item 7		
Type		431 / 433	433 PN 160	427 / 429
		DN 15 0.3 – 40 bar	DN 20 – DN 150 0.2 – 40 bar	DN 15 0.2 – 160 bar
				DN 20 – DN 150 1.5 – 40 bar
Disc	Item	1.4404	–	–
	7.1	316L	–	–
Retainer	Item	1.4404	–	–
	7.3	316L	–	–
Soft seal Materials, see page 99/10	Item	Sealing plate	–	–
	7.4		–	–
Lifting aid		see Item 7.1	–	–
		–	–	–
Nut	Item	1.4401	–	–
	7.5	8M	–	–

For temperature application limits, media resistance and option codes, see selection table on page 04/08.

Soft seal

Soft seal selection						
Abbreviation ASTM 14	Trade name (Designation)	Code letter ¹⁾	Option code	T _{min}	T _{max}	Application ²⁾
				[°C]	[°C]	
O-Ring						
CR	Neoprene®	K	J21	-40	100	Paraffins, mineral oils, silicon oils and greases, water and aqueous solutions, refrigerants, ozone
NBR	Buna-N® (Nitrile-Butadiene)	N	J30	-25	100	Hydraulic oils, plant and animal fats and oils
EPDM	Buna-EP (Ethylene-Propylene-Diene)	D	J22	-45	150	Hot water and hot steam up to 150 °C, 302 °F, many organic and inorganic acids, silicon oils and greases FDA conforming compound
FKM	Viton® (Fluorocarbon)	L	J23	20	180	High temperatures (not hot steam), mineral oils and greases, silicon oils and greases, plant and animal oils and fats, ozone FDA conforming compound on request
FFKM	Kalrez® (Perfluor)	C	J20	0	250	Almost all chemicals, standard compound is Kalrez® 6375 with steam resistance FDA conforming compound on request
Sealing plate						
SP	VESPEL SP-1® ³⁾ (Polyimide)	T	J49	-270	300	High-temperature and high-pressure applications (no steam), chemical resistance, see manufacturer's specifications
PCTFE	KEL-F® (Polychlorotri-fluoroethylene)	G	J48	-270	204	Low-temperature and refrigeration system applications, flammable media, gaseous acid up to 50 bar, 725 psig at 60 °C, 140 °F
PTFE	Teflon® (Polytetrafluoro-ethylene)	A	J44	-184	150	Almost all chemicals
Other not listed materials		X	For other materials, please contact your local representative or sales@leser.com.			

¹⁾ The code letters are stamped on the disc (Item 1)

²⁾ The pressure and temperature application range must be observed in all cases. The chemical resistance is based on specifications from the soft seal manufacturer. LESER assumes no guarantee.

³⁾ Only for DN 25, 1" x 2".

Disc – subassembly item 7

Disc with detachable lifting aid

A detachable lifting aid can be supplied for the valve disc on request as a variation of the standard disc with an integrally fixed lifting aid. The benefit of the detachable lifting aid is the easy re-lapping of the disc sealing surface on one disc.

This makes it possible to have fast maintenance of the safety valve on site.

The detachable lifting aid is standard with safety valves of type 431 / 433 PN 160.

Construction			
Type	431, 433	431, 433 PN 160	427, 429
Construction			Safety valves without lifting aid
Option code	J26	*	–

Materials		Disc with detachable lifting aid	
Item	Name	Steel	Stainless steel
Series 431 / 433			
1	Disc	1.4122 hardened Hardened stainless steel	1.4404 316L
2	Lifting aid	1.4581 CF10M	1.4581 CF10M
3	Roll pin	1.4310 Stainless steel	1.4310 Stainless steel
Series 431 / 433 PN 160			
1	Disc	1.4122 hardened Hardened stainless steel	1.4404 316L
2	Lifting aid	1.4104 Chrome steel	1.4404 316L
3	Circlip	1.4571 316Ti	1.4571 316Ti

Bull race disc

To prevent damages to the sealing surfaces from frequent disassembly, in particular for safety valves with short or regular service intervals, the disc can be supplied in a bull race construction as a custom design.

Construction			
Type	431, 433	431, 433 PN 160	427, 429
Construction			
Option code	J24	J24	J24

Balanced bellows – subassembly item 15

LESER offers a balanced bellows design for safety valves.

- Balanced bellows are used for two areas of applications:
- for compensation of the effect of back pressure
 - for reliable sealing of the bonnet against the blow-off chamber

Compensation of the effect of back pressure

The back pressure exerted on the back of the disc causes a force in the closing direction (F_C). The actual amount of the force is dependent on the diameter of the seat and the amount of back pressure. The balanced bellows forms a surface opposite the seat that matches the seat area. The back pressure also affects this surface and creates pressure F_O in the opening direction, which compensates for the force in the closing direction F_C .

The combination of the forces is shown in the following table:

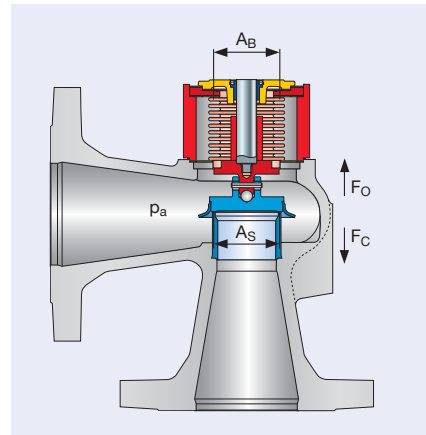

Effective area	Back pressure	Effective force	Direction of force	Compensation curves
Seat area = A_S	p_a	$F_C = p_a \times A_S$	closing	$A_S = A_B$
Bellows area = A_B	p_a	$F_O = p_a \times A_B$	opening	$F_C = F_O$

Sealing the bonnet from the outlet chamber

LESER's balanced bellows seal the spring chamber to the blow-off chamber. That way, they protect the guides, moving parts, and the spring against media-related affects such as dirt, corrosion, impurities, and also temperature.

Balanced bellows

Type	431 / 433	431 / 433 PN 160	427 / 429
Design			
Bonnet spacer	*	*	*
Bellows housing	-	*	-

The shield protects the bellows against flow turbulence when blowing off the valve. Vibrations in the bellows are reduced. This guarantees a longer service life of the bellows.

Control thread	DIN ISO 228-1, G 1/4	*	*	*
	ASME B1.20.1 NPT 1/2"	✓	✓	✓

To check the effectiveness of the bellows, an inspection connection G 1/4 is inserted into the bonnet as per DIN ISO 228-1. For safe discharge, especially of aggressive, toxic media, a discharge pipe G 1/4 can be installed if necessary.

Option code

Bonnet open	Standard bellows	J68	J68	J68
	Low pressure bellows	J68, J63	-	J68, J63
	Special materials	S15 + material name	S15 + material name	S15 + material name
Bonnet closed	Standard bellows	J78	J78	J78
	Low pressure bellows	J78, J63	-	J78, J63
	Special materials	S15 + material name	S15 + material name	S15 + material name
	Control thread NPT 1/2"	J95	J95	J95

The following information can be found on the respective pages of the selected valve:

- dimensions and weights, see "Dimensions and weights" table
- set pressure, see "Pressure temperature ratings" table
- temperature ranges, see "Pressure temperature ratings" table

Balanced bellows – subassembly item 15

Materials		Standard bellows
Item	Component	431 / 433, 431 / 433 PN 160, 427 / 429
15.1	Lower adaptor	1.4404 316L
15.2	Upper adaptor	1.4404 316L
15.3	Bellows	1.4571 316Ti
11	Bonnet spacer	1.4404 316L
55	Stud	1.4401 B8M
60	Gasket	Graphite / 1.4401 Graphite / 316

Bellows made of Hastelloy® or other special materials are available on request.

Balanced bellows conversion kits

With the LESER bellows conversion set, conventional construction safety valves can be converted to a balanced bellows design quickly and easily. The conversion set contains all the components needed for the conversion as well as a conversion guide.

Conversion kits				
Item	Component	No.	Materials	Remark
8	Guide	1	1.4404 316L	
11	Bonnet spacer	1	1.4404 316L	
12	Spindle	1	1.4404 316L	
15	Bellows	1	1.4571 316Ti	
55	Stud	4, 8 dependant on valve size	1.4401 B8M	
60	Gasket	2, 3 dependant on valve size	Graphite / 1.4401 Graphite / 316	
	Installation Instructions	1		LWN 037.05

Article numbers and spare parts, see the “Spare parts” section of the respective valve type.

Heating jacket

Application and construction

To protect systems with viscous, crystallising or sticky media, LESER offers a heating jacket.

The heating jacket has a welded design and covers the angle type body such that it allows the hot media (steam, oil, and so on) to flow through the created space.

In order to protect the spindle and moving parts against sticking, a safety valve with a balanced bellows construction should be chosen for the heating jacket construction.

For safety valves with balanced bellows, the bonnet spacer needed to accommodate the bellows is equipped with an additional heating jacket. Both heating jackets are joined by a threaded pipe bend.

If there is no danger of the medium setting in the blowoff chamber of the valve, then the balanced bellows don't have to be used. The position of the heating connections is shown in figures 1 to 3.

Specification for the heating jacket

The operating data of the heating jacket is placed on an additional heating jacket rating plate on the heating jacket.

Slip-on flange

Heating connections with flanges are designed for better orientation than slip-on flanges

Nominal pressure rating: PN 25 as per EN 1092-1
Class 150 as per ANSI 16.5

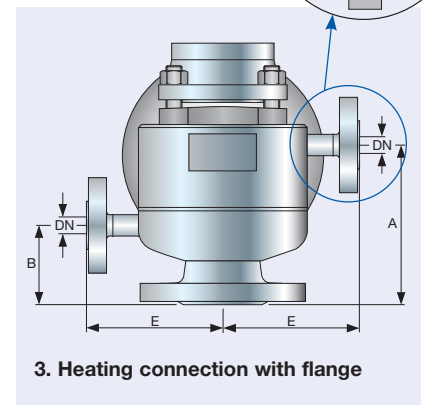
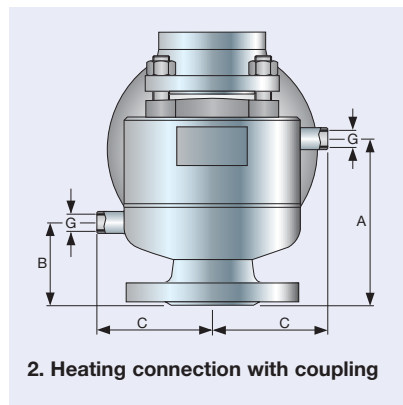
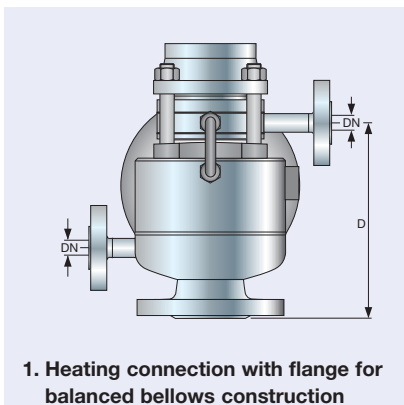

Heating jacket

Heating jacket														
DN _i	15	15	20	25	32	40	50	65	80	100	125	150		
Inlet valve size	1/2" x 1/2"	1/2" x 1/2"	3/4" x 3/4"	1" x 1"	1 1/4" x 1 1/4"	1 1/2" x 1 1/2"	2" x 2"	2 1/2" x 2 1/2"	3" x 3"	4" x 4"	5" x 5"	6" x 6"		
Actual orifice diameter d ₀ [mm]	12	12	18	18	18	23	29	37	46	60	74	92		
Materials														
Body	Series 429, 433	1.4408	1.4408	1.4408	1.4408	1.4408	1.4408	1.4408	1.0619 optional 1.4408	1.0619 optional 1.4408	1.0619 optional 1.4408	-	-	
Heating jacket								1.4541 321						
Connections														
Slip-on flange DIN	Option code	DN 15, PN 25	1.4571, 1.4404 316Ti, 316L											
	H 31									-	-	-	-	
Slip-on flange ANSI	H 32	DN 25, PN 25	-							1.4571, 1.4404 316Ti, 316L				
	K 31	1/2", CL150	1.4404 316L							-	-	-	-	
Coupling DIN 2986	K 32	1", CL150	-							1.4404 316L				
	H 29	G 3/8"	1.4571 316Ti							-	-	-	-	
Heating jacket Bonnet spacer	H 30	G 3/4"	-							1.4571 316Ti				
	H 33		1.4404 316L											

Metric units													
DN _E	15	15	20	25	32	40	50	65	80	100	125	150	
Inlet valve size	1/2" x 1/2"	1/2" x 1/2"	3/4" x 3/4"	1" x 1"	1 1/4" x 1 1/4"	1 1/2" x 1 1/2"	2" x 2"	2 1/2" x 2 1/2"	3" x 3"	4" x 4"	5" x 5"	6" x 6"	
Actual orifice diameter d ₀ [mm]	12	12	18	18	18	23	29	37	46	60	74	92	
Series 433, 429													
[mm]	A	95	95	95	95	105	120	130	150	170	165	-	-
	B	65	65	65	65	65	75	75	80	80	80	-	-
	C	83	83	83	83	95	95	95	110	120	145	-	-
	D	131	131	130	134	142	163	180	209	224	300	-	-
	E	110	110	110	110	120	121	121	136	150	176	-	-
	Slip-on flange DN	15	15	15	15	15	15	15	15	25	25	-	-
[inch]	Coupling G	3/8	3/8	3/8	3/8	3/8	3/8	3/8	3/8	3/4	3/4	-	-
Series 433, 429													
Operating temperature	20°C	25	25	25	25	25	25	25	15	15	15	-	-
	300°C	18	18	18	18	18	18	18	11	11	11	-	-

O-ring damper – subassembly item 40

The O-ring damper successfully prevents or reduces the vibrations of the moving parts of a safety valve.

Background:

In each safety valve, the moving parts – the disc, spindle, bottom spring plate and spring – form a so-called spring-mass-system. As in all spring-mass-systems, the components can be stimulated to start vibrating under unfavourable conditions (e.g. loss of inlet pressure). Vibrations can also be triggered by external units and then transferred to the safety valve via the mechanical connection or the medium. In the event of resonances, the safety valve opens and closes in an uncontrolled way at a high frequency and can't discharge the accorded mass flow.

In general, there are two types of uncontrolled vibrations (definition as per ASME PTC 25-2001, Chapter 2.7):

Chatter: “Abnormal rapid reciprocating motion of the movable parts of a pressure relief valve in which the disc contacts the seat.” The reasons for chatter may include, among other things, too high inlet pressure loss, inadmissible back pressure, or operation in partial load ranges.

Flutter: “Abnormal rapid reciprocating motion of the movable parts of a pressure relief valve in which the disc does not contact the seat.” The causes of flutter with small and difficult to measure amplitudes are vibrations coming from external sources. Possible external sources are piston compressors or pumps. The vibration can be transferred to the safety valve mechanically via the connections or through the medium.

Based on extensive experience with safety valves, LESER developed the o-ring damper on its certified test benches. The o-ring damper prevents the vibration of moving parts or reduces them to a non-critical frequency and amplitude. Nevertheless, the safety valve operates within the limits of the rules and regulations and standards. Through a special design, the o-ring damper can be used for any type of vibrations.

LESER offers the o-ring damper integrated in the cap H2 and as a modified lifting device H4. For applications with friction-reducing media, e.g. oil, a balanced bellows design is provided to protect the o-ring damper against the medium.

Available design

		Cap H2	Packed lever H4
Design			
Option code	Conventional design	J65	J66
	Balanced bellows design	J65, J78	J66, J78
O-ring temperature range		-20 °C to +180 °C	

O-ring damper – subassembly item 40

Availability		Cap H2 and Packed lever H4	
Valve size		Pressure range	
Series 433			
DN 15 1/2"		0.5 – 40 bar 7.25 – 580 psig	
DN 20 – DN 50 3/4" – 2"		0.5 – 40 bar 7.25 – 580 psig	
DN 65 – DN 80 2 1/2" – 3"		0.5 – 35 bar 7.25 – 508psig	
DN 100 4"		0.5 – 30 bar 7.25 – 435 psig	
DN 15 PN 160 O-ring disc 1/2"		11.3 – 103 bar 164 – 1494 psig	
DN 15 PN 160 steel disc 1/2"		9.01 – 100 bar 131 – 1450 psig	
Series 429			
DN 15 – DN 50 1/2" – 2"		0.5 – 40 bar 7.25 – 580 psig	
DN 65 – DN 80 2 1/2" – 3"		0.5 – 35 bar 7.25 – 508 psig	
DN 100 4"		0.5 – 30 bar 7.25 – 435 psig	

LESER guarantees perfect operation of the o-ring damper through extensive testing on the certified test benches. If an o-ring damper is needed for a pressure level that is not given in the table, then further tests are necessary. This leads to longer delivery times. Please contact sales@leser.com.

Materials		Cap H2	Packed lever H4
Item.	Component		
1	Lever cover	–	1.4408
		–	CF8M
2	Cap H2	1.4404	1.4404
		316L	316L
13	Cylindrical pin	–	1.4401
		–	B8M
14	Securing ring	–	1.4571
		–	316Ti
15	Spindle	–	1.4404
		–	316L
22	Clamping ring	1.4404	1.4404
		316L	316L
27	Bush	1.4404	–
		316L	–
27	Nozzle	–	PFTE 15% Glass
		–	PFTE 15% Glass
82	Spring	1.4310	1.4310
		Stainless steel	Stainless steel
83	O-Ring	FKM	FKM
		FKM	FKM

O-ring damper	Conversion kit
see respective main parts list	

Elastomer bellows

Application

Bellows seal the spring chamber to the blow-off chamber. That way, they protect the guides, moving parts, and the spring against media-related affects such as dirt, corrosion, and impurities. The elastomer bellows provides a cost-effective alternative to the balanced bellows.

The range of applications for the elastomer bellows is limited by:

- Chemical resistance
- Medium temperature
- Set pressure
- Back pressure

Elastomer bellows	
Design	
Construction	Easy, compact, and single-ply construction facilitates installation in small blow-off chambers. The one-piece design also facilitates easy replacement and extends the service life.
Flexibility	The special shape of the elastomer bellows provides good spindle mobility and prevents wear and tear.
Inspection hole	To check the effectiveness of the bellows, an inspection hole (Ø 10 mm) is put into the bonnet. This makes it possible to check the seal tightness of the bellows. In the event of a fault in the bellows, the medium leaks from this hole.
Construction height	No change

		Materials	
		Valve size	Option code
		DN 20 – 100	DN 20 – 150
		J79	J87 (DN 100 J87 + S70)
Item	Component		
70	Elastomer bellows	70 EPDM 281	45 NBR 670
		70 EPDM 281	45 NBR 670
71	Hose clamp	1.4301	1.4301
		304	304
72	Hose clamp	1.4301	1.4301
		304	304

Operating conditions	
Temperature ranges	[°C]
	-50 to +130
Set pressure	max. [bar _g]
	10
Built-up	[bar _g]
	up to 3

Lift indicator

The lift indicator is used in the process technology to monitor the operating condition of a safety valve.

Depending on the type of valve, LESER equips the packed lever H4 or the bonnets with the receptacle for the lift indicator.

For safety valves with lift indicators, the opening of the valve during opening or the lifting operation is signalled as of a specific lift (min. 1mm).

LESER uses inductive DC lift indicators with two-wire technology Type DIN EN 60947-5-6 (NAMUR). The indicators are approved for use in explosion-prone areas of Zone 0 (Ex II 1 D Ex iaD 20 T6). Other indicators that meet customer specifications can be used.

Technical data for lift indicators can be found on the manufacturer's homepage:
www.pepperl-fuchs.com

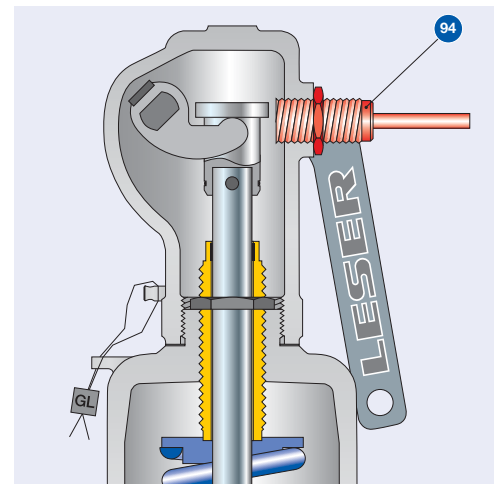

Packed lever H4

Gas-tight construction on request

For installation instructions for lift indicators, see LWN 323.02-E.

Availability

Item.	Name	Option code
40	Packed lever H4 with receptacle for lift indicator M18 x 1 [mm]	J39
94	Lift indicator M18 x 1, used type = PEPPERL+FUCHS NJ5-18GK-N	J93

Functional diagram

A, closed

For a closed valve, the lift indicator is positioned on the side, in front of the coupling or the control sleeve.

B, open

If the safety valve opens or if the safety valve is vented **(in both cases, min. 1 mm)** the lift indicator changes its state and switches. If the lift indicator unscrews, e.g. due to vibrations, there is also a switching operation.

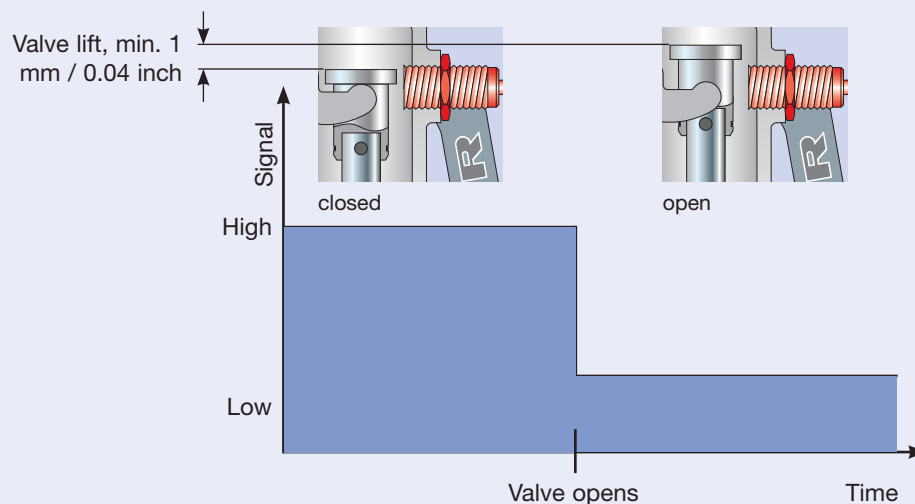

Lift restriction

The Lift restriction is used to adjust the safety valve to the required discharge mass flow and does not affect the operation of the safety valve.

A lift stopper must meet the requirements of the following codes and standards.

Requirements			
Code / Standards	EN ISO 4126-1, Section 5.1.3	ASME Code case 1945-4	AD 2000-Merkblatt A2, Section 10.3
Lift	≥ 30% of the full lift not less than 1.0 mm	≥ 30% of the full lift not less than 2.0 mm	not less than 1.0 mm
Coefficient of discharge	-	-	$\alpha_w [S/G] \geq 0.08$
	-	-	$\alpha_w [L] \geq 0.05$
Name plate marking	Identification of the reduced coefficient of discharge	- Capacity replaced by "Limited capacity" - Limited lift = ___ mm	Identification of the reduced coefficient of discharge
Design according to EN ISO 4126-1	For valves with a lift stopper to adapt to the required discharge mass flow, this device must not have an adverse effect on the operation of the valve. If it is adjustable, the lift stopper device must be setup such that the adjustable part can be mechanically secured and sealed. The lift stopper device must be installed and sealed by the manufacturer.		

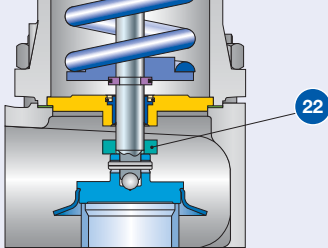
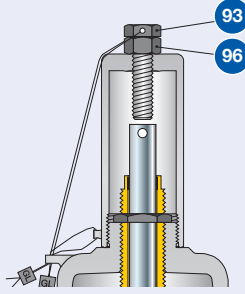
Lift restriction		Lift restriction by bush	Lift restriction by gag
Design			
Option code		J51	Cap H2: J52 Packed lever H4: J50
Availability			
Series 433		✓	✓
Series 429		-	-
Materials			
Item.	Component		
22	Bush	1.4404	-
		316L	-
93	Stud	-	1.4401
		-	B8M
96	Nut	-	1.4401
		-	8M

LESER worldwide

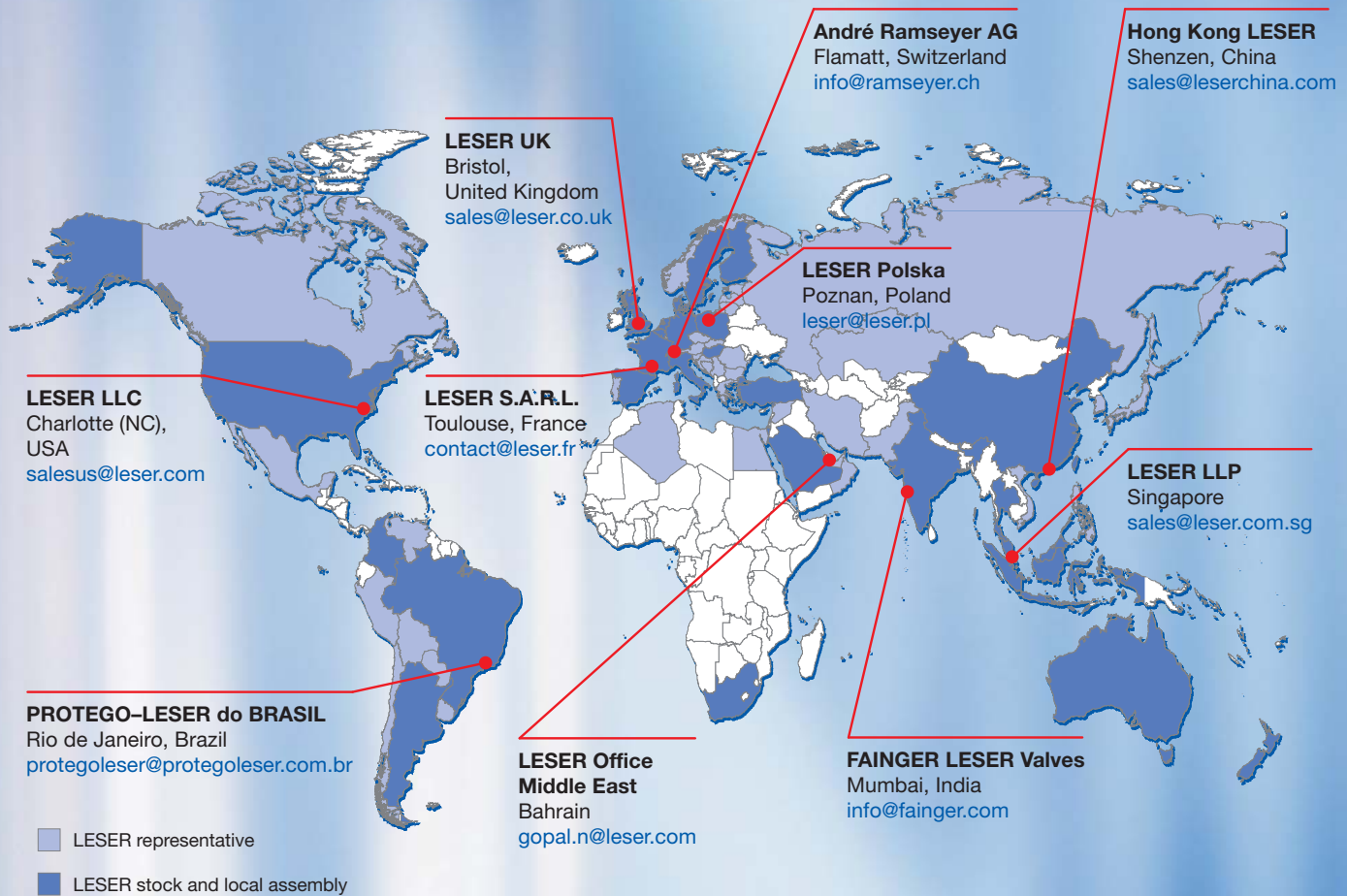

Modulate Action
Edition January 2011 / 2000

LWN 485.01-E / 0777.5646

LESER

The-Safety-Valve.com

LESER GmbH & Co. KG

20537 Hamburg, Wendenstr. 133-135
20506 Hamburg, P.O. Box 26 16 51

Fon +49 (40) 251 65-100
Fax +49 (40) 251 65-500

Email: sales@leser.com
www.leser.com