



MODEL BK2

TECHNICAL SPECIFICATIONS



with clamping hub

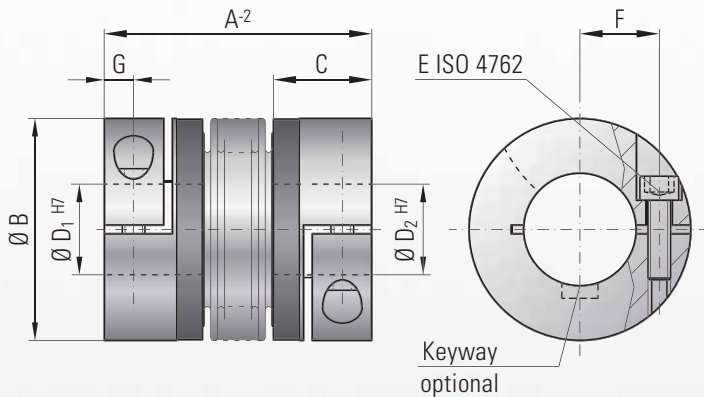

Ordering example

BK2 / 80 / 94 / 20 / 25.4 / XX

Model
Series / Nm
Overall length
Ø D1 H7
Ø D2 H7
Non standard e.g. stainless steel

Properties:

- easy to mount
- suited for space restricted installations
- low moment of inertia

Material:

Bellows made of highly flexible high-grade stainless steel, hub material: see table below

Design:

With a single radial clamping screw per hub ISO 4762. Any imbalance of the clamping hubs is compensated for by balancing bores located on the inside of the hub.

Temperature range:

-30 to +120° C (3.6 F - 270 F)

Speeds:

Up to 10,000 rpm, in excess of 10,000 available with a finely balanced version.

Service life:

These couplings are maintenance-free if the technical ratings are not exceeded.

Backlash:

Absolutely backlash-free due to frictional clamp connection.

Brief overloads:

Acceptable up to 1.5 times the value specified.

Tolerance:

On the hub/shaft connection 0.01 to 0.05 mm

Non-standard application:

Custom designs with varied tolerances, keyways, non-standard material and bellows are available upon request.

Model BK 2		Series																			
		15		30		60		80		150		200		300		500		800		1500	
Rated torque (Nm)	T_{KN}	15		30		60		80		150		200		300		500		800		1500	
Overall length (mm)	A	59	66	69	77	83	93	94	106	95	107	105	117	111	125	133	146	140	166		
Outer diameter (mm)	B	49		55		66		81		81		90		110		124		134		157	
Fit length (mm)	C	22		27		31		36		36		41		43		51		45		55	
Inner diameter possible from Ø to Ø H7 (mm)	$D_{1/2}$	8-28		10-30		12-32		14-42		19-42		22-45		24-60		35-60		40-75		50-80	
ISO 4762 fastening screw	E	M5		M6		M8		M10		M10		M12		M12		M16		2xM16*		2xM20*	
Tightening torque of the fastening screw (Nm)		8		15		40		50		70		120		130		200		250		470	
Distance between centers (mm)	F	17		19		23		27		27		31		39		41		2x48		2x55	
(mm)	G	6.5		7.5		9.5		11		11		12.5		13		16.5		18		22.5	
Moment of inertia (10^{-3} kgm ²)	J_{total}	0.07	0.08	0.14	0.15	0.23	0.26	0.65	0.67	2.5	3.2	4.5	5.4	8.5	10.5	17.3	19.6	24.3	49.2		
Hub material (standard) (steel on request)		Al		Al		Al		Al		steel		steel		steel		steel		steel		steel	
Approx. weight (kg)		0.15		0.3		0.4		0.8		1.7		2.5		4		7.5		7		12	
Torsional stiffness (10^3 Nm/rad)	C_T	20	15	39	28	76	55	129	85	175	110	191	140	450	350	510	500	780	1304		
axial	Max. values	1	2	1	2	1.5	2	2	3	2	3	2	3	2.5	3.5	2.5	3.5	3.5	3.5		
lateral		0.15	0.2	0.2	0.25	0.2	0.25	0.2	0.25	0.2	0.25	0.25	0.3	0.25	0.3	0.3	0.35	0.35	0.35		
axial spring stiffness (N/mm)	C_a	25	15	50	30	72	48	48	32	82	52	90	60	105	71	70	48	100	320		
lateral spring stiffness (N/mm)	C_r	475	137	900	270	1200	420	920	290	1550	435	2040	610	3750	1050	2500	840	2000	3600		

(1Nm \approx 8.85 in lbs) max. angular misalignment see BK 1 * two screws each hub, 180° apart