

Table of contents

	Page
Safety notes / Technical support	2
<hr/>	
Introduction	3
<hr/>	
Technical data	4
Electrical data	4
Dimensions	6
Mechanical data	10
<hr/>	
Options/ Accessories	12
<hr/>	
Operating conditions	13
<hr/>	
Approvals	15
<hr/>	
Installation	16
Mechanical installation	16
Electrical installation	22
<hr/>	
Notes for use in Hazardous Locations	29
<hr/>	
Operation	34
Operating elements / LED's	34
Factory calibration	35
Recalibration	36
Advanced calibration	37
Advanced possibilities	41
WHG Proof Test	43
<hr/>	
Troubleshooting	45
<hr/>	
Transport and Storage	46
<hr/>	
Maintenance	47
<hr/>	
Probe modifications	48
<hr/>	
Disposal	48

Subject to technical change.

We assume no liability for typing errors.

Different variations than specified are possible.
 Please contact our technical consultants.

Safety notes / Technical support

Notes

- Installation, maintenance and commissioning may be accomplished only by qualified technical personnel.
- The product must be used only in the manner outlined in this instruction manual.

Special attention must be paid to warnings and notes as follows:

WARNING



Relates to a caution symbol on the product: A failure to observe the necessary precautions can result in death, serious injury and/or considerable material damage.

WARNING



Relates to a caution symbol on the product: Risk of electric shock

WARNING





A failure to observe the necessary precautions can result in death, serious injury and/or considerable material damage.

This symbol is used, when there is no corresponding caution symbol on the product.

CAUTION

A failure to observe the necessary precautions can result in considerable material damage.

Safety symbols

In manual and on product	Description
	CAUTION: refer to accompanying documents (manual) for details.
	Earth (ground) Terminal
	Protective Conductor Terminal

Technical support

Please contact your local supplier (for address see www.uwt.de). Otherwise you can contact:

UWT GmbH
 Westendstr. 5
 D-87488 Betzigau
 Germany

Tel.: 0049 (0)831 57123-0
 Fax: 0049 (0)831 76879
info@uwtgroup.com
www.uwtgroup.com

Introduction

Measurement principle

The Capanivo series CN 7000 detects the capacitance around its probe. Due to the active shield technology it has an increased insensitivity to material buildup on the probe.

Applications

The Capanivo series CN 7000 is a capacitance switch for:

- Level detection of liquids, solids (powder and granules), slurries and foam.
- Interface detection (for example, oil / water or foam / liquid)

It works in all types of vessels, pipes and silos within a wide range of applications like:

- Food, brewery, dairy, beverage and pharmaceuticals
- Chemical and petrochemical
- Water and waste water
- Machine building industry

It can also be used for leakage detection in double walled vessels, tanks and silos or in moldings and collecting ponds.

Features

Process

- Measurement independent from influence of the vessel wall
- Factory provided precalibration allows measurement of most applications without sensitivity setting on site
- Active shield electrode for compensation of material buildup
- Potted construction protects from shock, vibration, humidity, condensation
- Dielectric constant of 1.5 or more
- Process temperature up to 125°C
- Intrinsically Safe (IS) design for Hazardous areas (requires external barrier)
- Approvals CE, ATEX, IEC-Ex, FM, CSA, INMETRO, TR-CU, KC, WHG

Electronics

- 4-wire DC with Relais signal output
- 2-wire 8/16 mA
- 4-20mA continuous mode
(4mA = uncovered probe, 20mA = probe covered with high dielectric material)
- Terminal or M12 connection
- Sensitivity setting by potentiometer, including visual feedback via LED
- Remote Test with external signal conditioning instrument

Mechanics

- Corrosion resistant construction with enclosure made of thermoplastic polyester, wetted parts made of PPS, PVDF, PEEK and 316L stainless steel
- Compact probe length
- Pipe extension (max. 4m), optional sliding sleeve allows to change the switch point easily during operation of the device
- Cable extension (max. 20m), cuttable by user
- Various process connections: threaded (including G $\frac{1}{2}$ " hygienic), flanged (screwed) or Tri-clamp

Technical data

Electrical data

Standard version (General Purpose) Power supply / signal output	4-wire operation with DC supply and relay Supply: 9 - 33 V DC, 0.7W incl. 10% of EN 61010-1 Signal output: Relay SPST Max. switching voltage: 60 V DC or 30 V AC; Limited to 35 V DC or 16 V AC in wet locations Max. switching current / switching power: 1 A / 60 W 2-wire operation with 8/16 mA loop 9 - 33 V DC, 0.7W incl. 10% of EN 61010-1 8/16 mA Tolerance: 8mA +/-0,5mA, 16mA -1mA/+2mA If required, the unit can be set to 4-20mA continuous current output (direct output of the measured capacitance). The stated voltage is the resulting voltage on the unit. Any voltage drop on an external series resistance must be considered.
Intrinsically safe version Power supply / signal output	2-wire operation with 8/16 mA loop 10.8 - 30 V DC, 0.7W incl. 10% of EN 61010-1 8/16 mA or 16/8 mA Tolerance: 8mA +/-0,5mA, 16mA -1mA/+2mA Intrinsically safe barrier or signal conditioning instrument required: $U_i=30\text{ V}$ $I_i=160\text{ mA}$ $P_i=0,8\text{ W}$, $C_i=7,6\text{ nF}$ $L_i=0,3\text{ mH}$ If required, the unit can be set to 4-20mA continuous current output (direct output of the measured capacitance). The stated voltage is the resulting voltage on the unit. Any voltage drop on an external series resistance must be considered.
	4-wire operation with DC supply and solid state relay This operation is only available for CN 7120/7121 with enclosure Ø65mm and connection via terminal block (Solid state relay integrated). Supply: 10.8 - 30 V DC, 0.7W incl. 10% von EN 61010-1 Intrinsically safe barrier required: $U_i=30\text{ V}$ $I_i=160\text{ mA}$ $P_i=0,8\text{ W}$, $C_i=7,6\text{ nF}$ $L_i=0,3\text{ mH}$ Signal output:: Solid state relay Max. switching voltage / current: 30 V DC / 82mA For connection to an intrinsically safe "switch amplifier for contact input" or to an intrinsically safe PLC with integrated input card for contact input. $U_i=30\text{ V}$ $I_i=200\text{ mA}$ $P_i=350\text{ mW}$, $C_i=4,2\text{ nF}$ $L_i=0$ The power supply circuit is infallibly galvanically isolated from the transistor circuit.
Safety operation (FSL,FSH)	Selectable for minimum or maximum safety by polarity of power supply voltage
Signal delay	Probe uncovered -> covered ca. 0.5 sec Probe covered -> uncovered ca. 0.5 sec
Indicating light	Build in LEDs: Power (green), Signal output (yellow), Sensor status / Diagnostics (white)
Sensitivity	Adjustable by potentiometer

Technical data

Electrical connection	With enclosure Ø65mm: Terminal block, terminals 0.14 - 1.5 mm ² (AWG 28-16)
	With enclosure Ø65mm and Ø35mm: M12x1 according to IEC 61076-2-101, male, 4-pole, coding A-standard
Cable entry	With enclosure Ø65mm: M20 x 1.5 screwed cable gland Clamping range (diameter) of factory provided cable glands: 6..12 mm (0.24 .. 0.47") or NPT 1/2" conduit
Overvoltage category	II
Protection class	III

Diagnostics / Remote function test

The units starts a self diagnostics routine when the power supply is applied or interrupted for >2 seconds.

The loop current shows following behavior, which can be evaluated by an external signal conditioning instrument (accessory) or by a PLC:

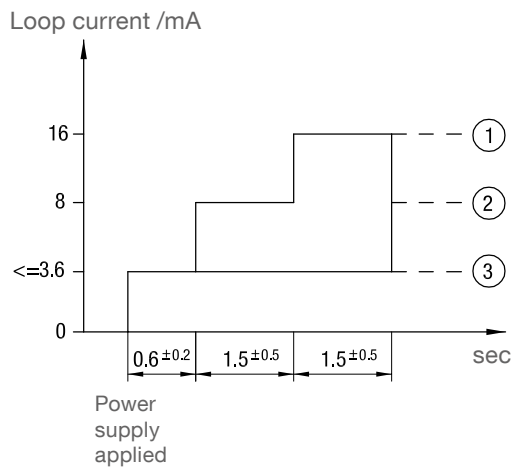

- 1 or 2:
 Diagnostics test is o.k.
 Measurement signal is present:
 - Loop current = 8 or 16mA
 - Relay = open or closed (depending on setted output logic, see page 26)
- 3:
 Diagnostics test failed:
 - Loop current <=3,6mA
 - Relay = open

Technical data

Dimensions All dimensions in mm (inch)

CN 7120 - Short extension length Stainless steel process connection

Enclosure Ø65mm

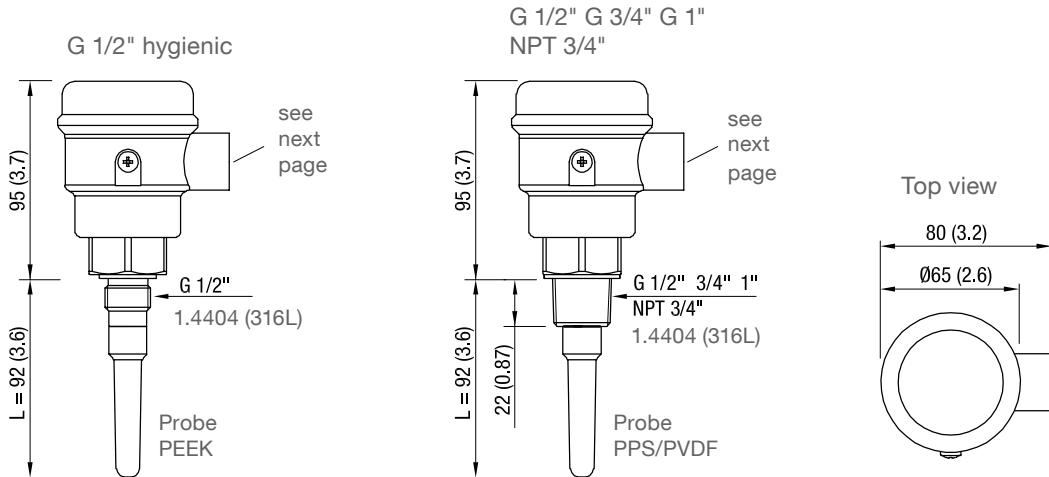

Enclosure Ø35mm

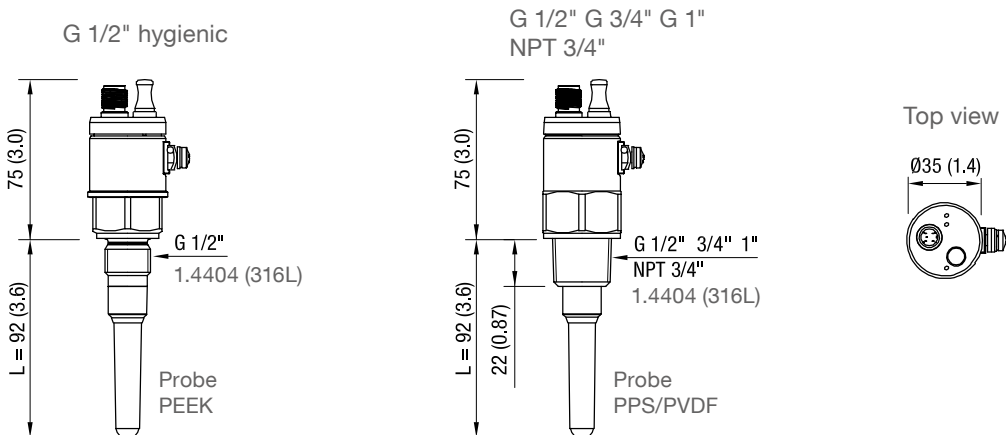

CN 7121 - Short extension length Plastic process connection

Enclosure Ø65mm

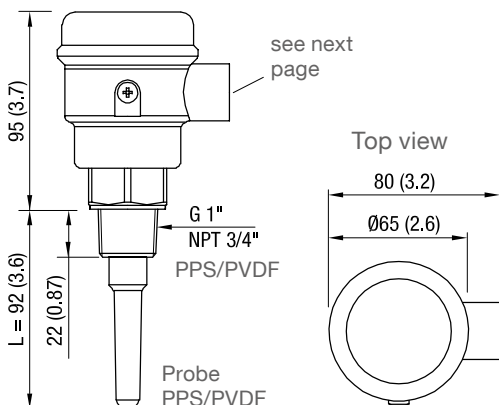

Enclosure Ø35mm

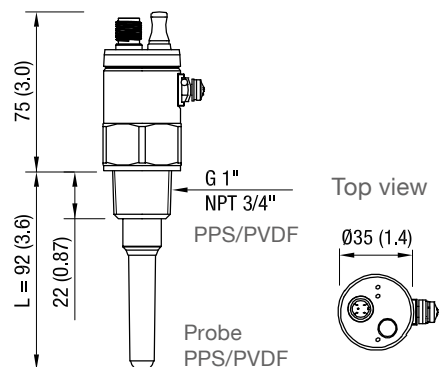

Technical data

CN 7130 - Pipe extension
 CN 7150 - Cable extension

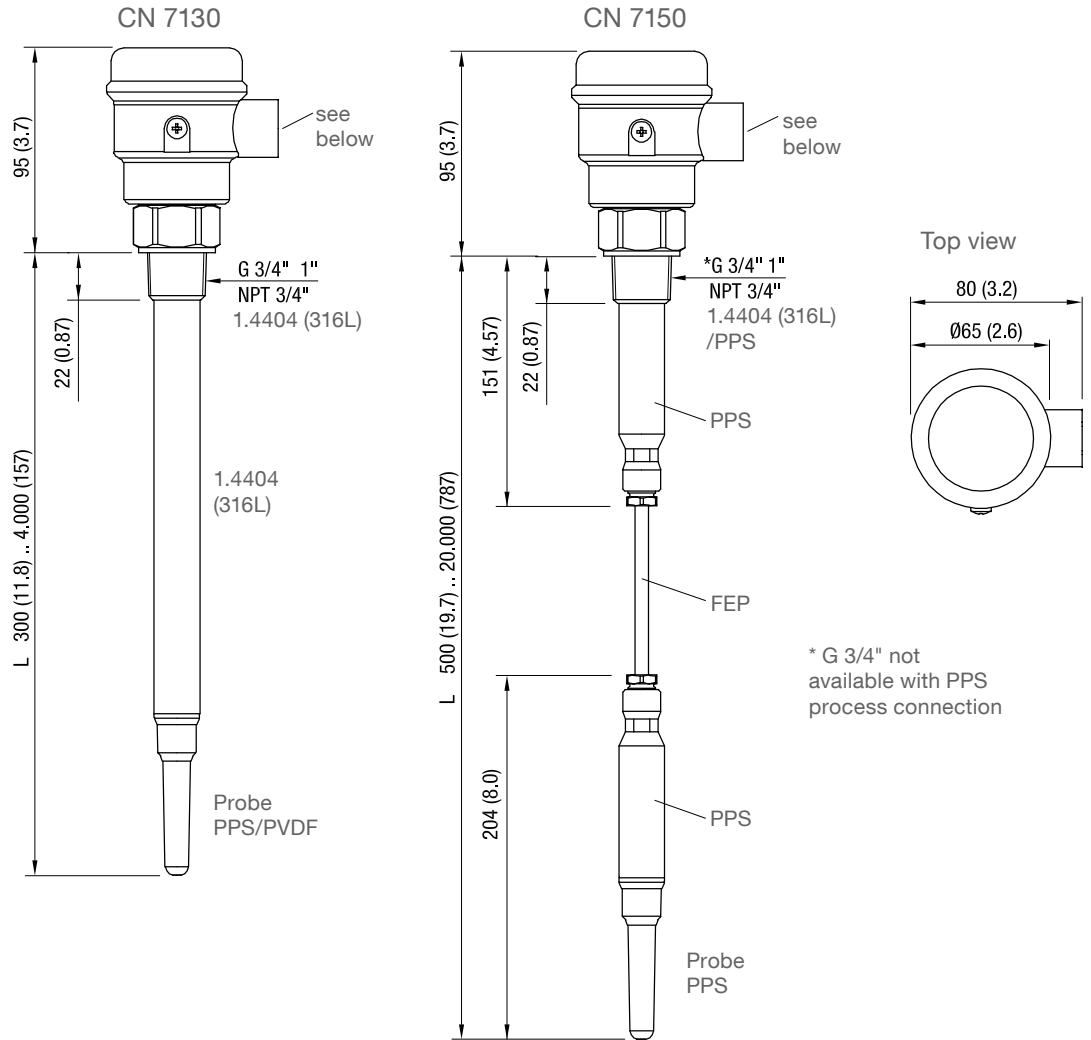

Enclosure
Ø65mm
 Possible wiring

M20x1,5
 cable gland

1/2" NPT
 conduit

M12
 plug

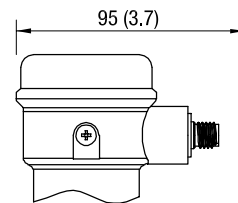
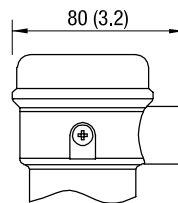
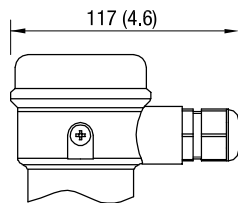

Technical data

Tri-clamp

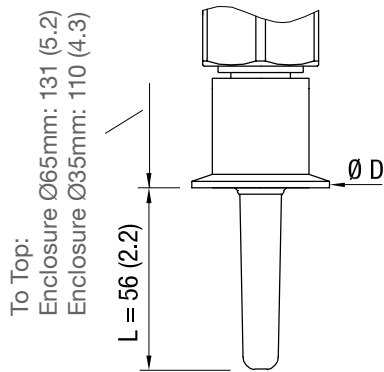

Tri-clamp	ØD
DN 25 (1")	50,5 (1.99")
DN 40 (1 1/2")	64 (2.52")
DN 50 (2")	64 (2.52")

Flange

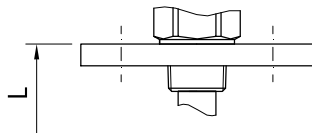

Flange is screwed to process connection

	Code	Type	Number of holes	d2 mm (Inch)	Lk mm (Inch)	D mm (Inch)	T thickness mm (Inch)
ASME B16.5, raised face	R	1" 150 lbs	4	15,9 (0.63)	79,3 (3.12)	108,0 (4.25)	14,3 (0.56)
	S	1" 300 lbs	4	19,1 (0.75)	88,9 (3.5)	123,8 (4.87)	17,5 (0.69)
	T	1½" 150 lbs	4	15,9 (0.63)	98,6 (3.88)	127,0 (5.0)	17,5 (0.69)
	U	1½" 300 lbs	4	22,2 (0.87)	114,3 (4.5)	155,6 (6.13)	20,6 (0.81)
	V	2" 150 lbs	4	19,1 (0.75)	120,7 (4.75)	152,4 (6.01)	19,1 (0.75)
	W	2" 300 lbs	8	19,1 (0.75)	127,0 (5.0)	165,1 (6.5)	22,2 (0.87)
EN 1092-1 type A, flat faced	N	DN25 PN16/40	4	14,0 (0.55)	85,0 (3.35)	115,0 (4.53)	18,0 (0.71)
	P	DN40 PN16/40	4	18,0 (0.71)	110,0 (4.33)	150,0 (5.91)	18,0 (0.71)
	Q	DN50 PN16/25/40	4	18,0 (0.71)	125,0 (4.92)	165,0 (6.5)	18,0 (0.71)

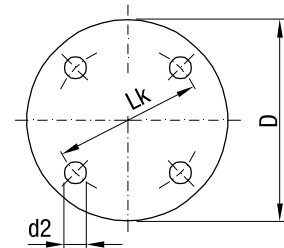

Raised face

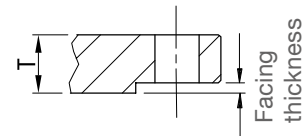

Type	Facing thickness
ASME 150 lbs	2 mm (0.08")
ASME 300 lbs	

Technical data

CN 7120 - G 1/2" hygienic process connection / EHEDG approval

EHEDG versions

EHEDG approval is available with CN7120 with process connection G 1/2" hygienic

CN 7120 process connection

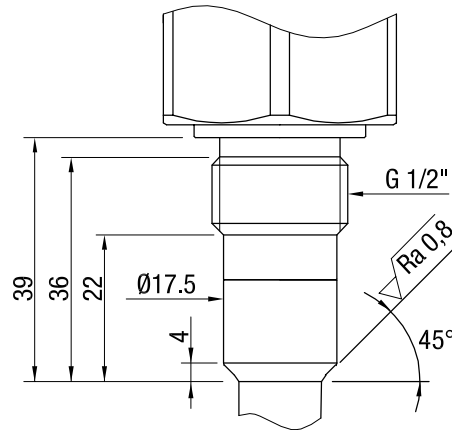

Metal
 1.4404 (316L)

PEEK
 FDA registration number:
 21 CFR 177.2415

Flush welding socket: Design

The flush welding socket must meet the following design:

Metal type according to hygienic and further external requirements.

Detail A:
 Sealing area between CN 7120 (PEEK) and the on site process connection (metal)

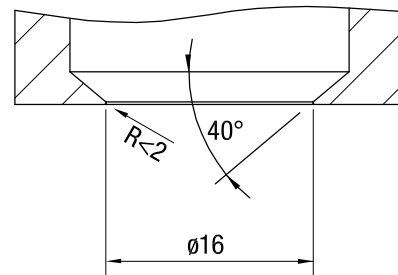
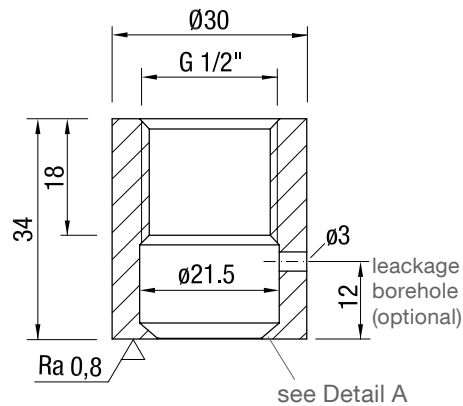

Flush welding socket: Installation

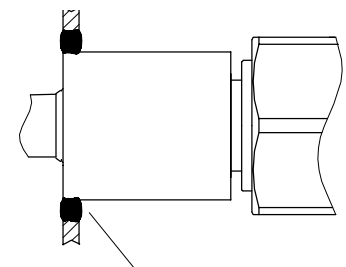
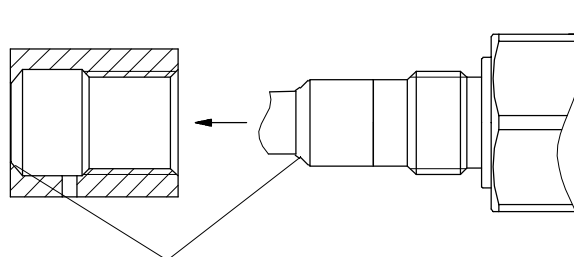

Metal-peek sealing

- The support must be plane and without any gap. No teflon tape (or similar) is allowed to be in between.
- Fixing torque 30 Nm

The quality of the welding with the container wall must be according to the respective regulations (e.g. gaps, transitions, surface finish).

Technical data

Mechanical data

Process connection and extension

CN 7120 - Stainless steel process connection, version G 1/2" Hygienic:

Material process connection:	1.4404 (316L)
Material probe:	PEEK ^(1,2)
Seal process connection-probe:	FKM (optional FFKM) ⁽²⁾
Thread ⁽³⁾ :	G 1/2" Hygienic
Wetted sensor surface:	Ra ≤ 0.8 µm (31 µin)
Hygienic design:	EHEDG

CN 7120 - Stainless steel process connection:

Material process connection:	1.4404 (316L)
Material probe:	PPS (glass fibre reinforced) ^(1,2) Optional PVDF ^(1,2)
Seal process connection-probe:	FKM (optional FFKM) ⁽²⁾
Thread ⁽³⁾ :	G 1/2", G 3/4", G 1", NPT 3/4" Adapters for G 1 1/2", NPT 1 1/4", NPT 1 1/2"
Tri-clamp	DN25 (1"), DN40 (1 1/2"), DN50 (2") DIN 32676 Type A (DIN 11851) and DIN 32676 Type C (ASME BPE 2009)
Flange (screwed) ⁽⁴⁾	DN 25, 40, 50; ASME 1", 1 1/2", 2"

CN 7121 -Plastic process connection:

Material process connection:	PPS (glass fibre reinforced) ^(1,2) Optional PVDF ^(1,2)
Material probe:	PPS (glass fibre reinforced) ^(1,2) Optional PVDF ^(1,2)
Seal process connection-probe:	FKM (optional FFKM) ⁽²⁾
Thread ⁽³⁾ :	G 1", NPT 3/4"

CN 7130 - Pipe extension:

Material process connection:	1.4404 (316L)
Material pipe extension:	1.4404 (316L)
Material probe:	PPS (glass fibre reinforced) ^(1,2) Optional PVDF ^(1,2)
Seal pipe-probe:	FKM (optional FFKM) ⁽²⁾
Thread ⁽³⁾ :	G 3/4", G 1", NPT 3/4" Adapters for G 1 1/2", NPT 1 1/4", NPT 1 1/2"
Flange (screwed) ⁽⁴⁾	DN 25, 40, 50; ASME 1", 1 1/2", 2"

CN 7150 - Cable extension, with process connection 1.4404 (316L):

Material process connection:	1.4404 (316L)
Material extension cable:	FEP jacketed
Material probe and extension cable fixing:	PPS (glass fibre reinforced) ^(1,2)
Seal process connection- extension cable:	FKM (optional FFKM) ⁽²⁾
Seal extension cable- probe:	FKM (optional FFKM) ⁽²⁾
Thread ⁽³⁾ :	G 3/4", G 1", NPT 3/4" Adapters for G 1 1/2", NPT 1 1/4", NPT 1 1/2"
Flange (screwed) ⁽⁴⁾	DN 25, 40, 50; ASME 1", 1 1/2", 2"

Technical data

CN 7150 - Cable extension, with process connection PPS:

Material process connection:	PPS (glass fibre reinforced) ^(1,2)
Material cable extension:	FEP jacketed
Material probe and extension cable fixing:	PPS (glass fibre reinforced) ^(1,2)
Seal process connection- extension cable:	FKM (optional FFKM) ⁽²⁾
Seal cable- probe:	FKM (optional FFKM) ⁽²⁾
Thread ⁽³⁾ :	G 1", NPT 3/4"
	Adapters for G 1 1/2", NPT 1 1/4", NPT 1 1/2"

⁽¹⁾ Discolouration is possible due to influence of UV and temperature. This has no negative effect to the material properties.

⁽²⁾ Food grade, FDA registration number:

Seals	21 CFR 177.2600
PVDF	21 CFR 177.1550
PPS	21 CFR 175.300
PEEK	21 CFR 177.2415

⁽³⁾ Thread types: G = DIN ISO 228-1 NPT = ASME B 1.20.1

⁽⁴⁾ Flange pressure rating: DN25 PN16/40, DN40 PN16/40, DN50 PN16/25/40
 ASME 150lbs, ASME 300lbs

Extension length "L"	CN 7120 Stainless steel process conn.:	92 mm (3.6")
	CN 7121 Plastic process connection:	92 mm (3.6")
	CN 7130 Pipe extension:	300 .. 4000mm (11.8 .. 157")
	CN 7150 Cable extension:	400 .. 20.000mm (15.7 .. 787")
Tolerance length "L"	CN 7120 Stainless steel process conn.:	±5 mm (±0.2")
	CN 7121 Plastic process connection:	±5 mm (±0.2")
	CN 7130 Pipe extension:	±10 mm (±0.4")
	CN 7150 Cable extension:	±15 mm (±0.6")
Material Enclosure Ø65mm	Material Housing: Thermoplastic polyester (PBT/PC) Material Lid: Transparent thermoplastic polycarbonate (PC) Material Seal between housing and lid: VMQ (vinyl-methyl-silicone) Material Nameplate: polyester film	
Material Enclosure Ø35mm	Material Housing: 1.4404 (316L) Material Lid with M12 plug: Transparent thermoplastic polycarbonate (PC) Material Seal between housing and lid: VMQ (vinyl-methyl-silicone) Material Nameplate: polyester film	
Ingress protection	Type 4X / IP68	
Sound level	n.a. (no sound is produced)	
Overall weight (ca.)	CN 7120 Stainless steel process conn.:	0.35 kg (0.77 lbs)
	CN 7121 Plastic process connection:	0.25 kg (0.55 lbs)
	CN 7130 Pipe extension:	0.6 kg (1.32 lbs) + 0.85 kg/m (1.87 lbs per 39.3")
	CN 7150 Cable extension:	0.6 kg (1.32 lbs) + 0.08 kg/m (0.18 lbs per 39.3")
	All weights with threaded process connection.	

Options / Accessories

Options

Sliding sleeve
 CN 7130

G 1 1/4" / G 1 1/2" / NPT 1 1/4" / NPT 1 1/2"
 Material: 1.4404 (316L)
 Sealing material to the extension pipe: FKM
 Max. process pressure: -1 to 10 bar (146 psi)

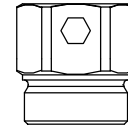

Accessories

Adapter for process connection

Adapter from G 1" thread to G 1 1/2"
 Adapter from NPT 3/4" thread to NPT 1 1/4" / NPT 1 1/2"

Material: 1.4305 (303) or 1.4404 (316L)
 Max. process pressure: -1 to 25 bar (363 psi)

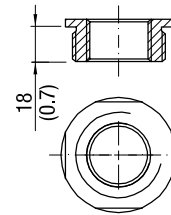

Flush welding socket

For version with EHEDG certificate
 Fitting to CN 7120 with process connection G 1/2" hygienic

Flush welding socket $\varnothing 30$ / G 1/2", 1.4404 (316L),
 with or without leakage borehole

Details see page 9

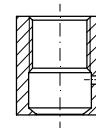

Shortening kit For CN 7150 extension cable

Sensguard

Outer thread (process connection):
 G1" DIN ISO 228-1 or NPT 3/4" ASME B 1.20.1
 Internal thread:
 G 1/2" (requires CN 7120 with process connection G 1/2" to fit in).
 Material: PPS
 Max. process pressure: -1 to 10 bar (146 psi)

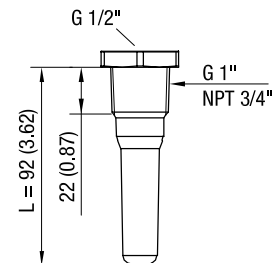

Complementary products (from outside companies)

Remote instrument **Operation with 8/16 mA, 2-wire current loop:**
 Input: 8/16 mA from CN 7000 unit
 Output: Relay
 Intrinsically safe and non-intrinsically safe operation:
 Implements self diagnostics when power supply is applied or test button on remote instrument is pressed (remote test, see page 5 and page 40-41)

M12 mating plug 4 pole, for version with M12 plug

Operating conditions

Functional

Dielectric constant Min. 1.5
 Factory setting = 2.0
 For dielectric constant of applicable materials: see external dielectric constant tables

Switching point Depending on setting of potentiometer and dielectric constant value of measured material. See page 33 for details.

Repeatability 2 mm (0.08"), for water based liquids

Environment

Ambient and process temperature
 (Non-Ex version)

Mounting with short socket

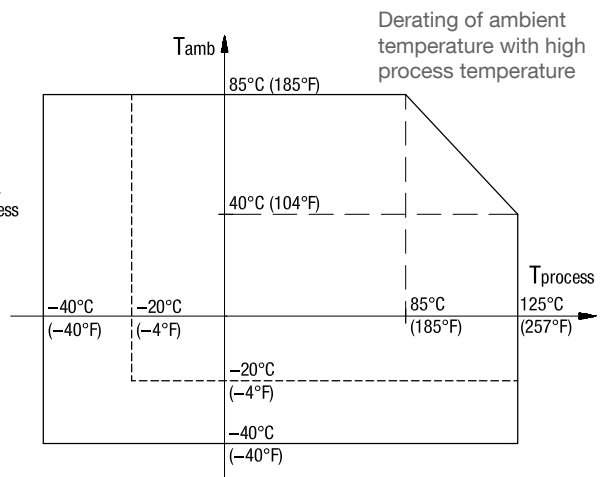
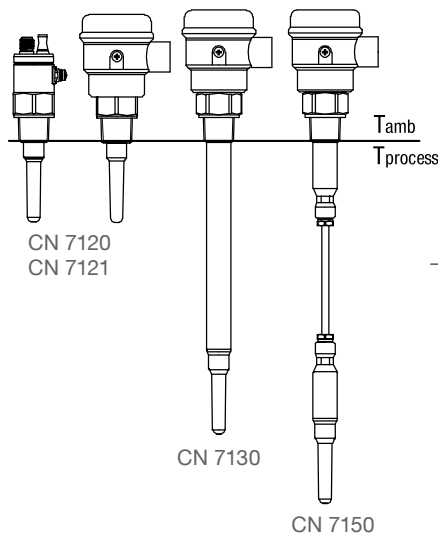

Ambient- and process temperature limited to -20°C (-4°F) with option FFKM seal O-ring

Mounting with long socket

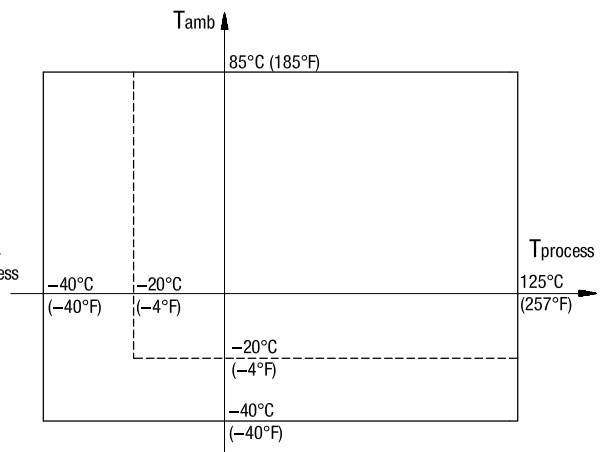
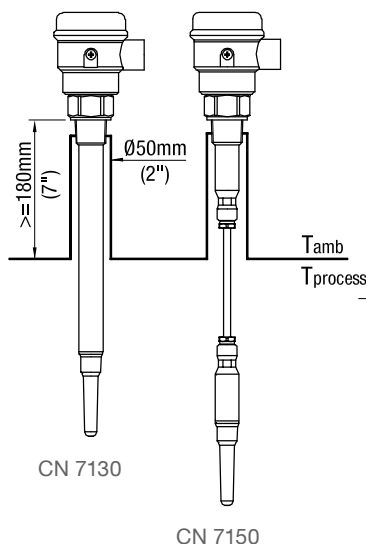

Ambient- and process temperature limited to -20°C (-4°F) with option FFKM seal O-ring

Operating conditions

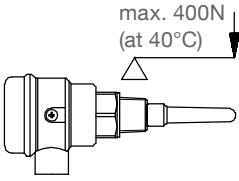
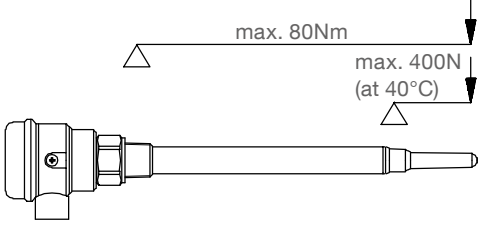
Ambient and process temperature (Ex versions)	Depending on Surface Temperature and Temperature Class, details see page 29.	
Max. temperature for CIP	135°C (275°F), duration 60min 150°C (302°F), duration 30min (only for CN 7120 with process connection G 1/2" hygienic) Ambient temperature limited to 50°C (122°F), unit de-energized.	
Max. permitted mechanical torque	CN 7120 / CN 7121	CN 7130
	 <p>max. 400N (at 40°C)</p>	 <p>max. 80Nm max. 400N (at 40°C)</p>
Max. tractive force	CN 7150	1.7 kN (at 40°C)
Max. process pressure	CN 7120 Stainless steel process connection: -1 to 25 bar (363 psi) CN 7121 Plastic process connection: -1 to 10 bar (146 psi) CN 7130 Pipe extension: -1 to 25 bar (363 psi) CN 7130 Pipe extension with sliding sleeve: -1 to 10 bar (146 psi) CN 7150 Cable extension: -1 to 10 bar (146 psi)	
	Observe possible pressure limitation from the used flange type !	
Pollution degree	4	
Relative Humidity	0 - 100%, suitable for outdoor use	
Altitude	max. 3.000 m (9.843 ft)	
Ventilation	Ventilation is not required	
Expected product lifetime	Following parameters have a negative influence on the expected product lifetime: High ambient- and process temperature, corrosive environment, high vibration, high flow rate of abrasive bulk material passing the probe.	

Approvals

General Purpose * (Ordinary Locations)	CE UKCA FM / CSA TR-CU
Hazardous Locations *	Intrinsically Safe: ATEX II 1G, 1/2G Ex ia IIC ATEX II 1/2D Ex ia IIIC IEC Ex ia IIC IEC Ex ia IIIC FM / CSA IS Class I, II, III, Div. 1, Gr. A-G TR-CU 0Ex ia IIC TR-CU Ex ia IIIC INMETRO Ex ia IIC INMETRO Ex ia IIIC KC Ex ia IIC KC Ex ia IIIC CCC Ex ia IIC CCC Ex iaD 20/A21 UKEX II 1G, 1/2G Ex ia IIC UKEX II 1/2D Ex ia IIIC
Overfill and leakage protection *, **	WHG VLAREM
EMC	EN 61326
RoHS conform	According to directive 2011/65/EU
Food grade material	Wetted parts with FDA registration. Details see "Mechanical data".
Pressure Equipment Directive (2014/68/EU)	The units are not subject to this directive, because they are classified as „pressure-keeping equipment“ and do not have a pressurized housing (see Art.1, clause 2.1.4). The units are designed and manufactured in accordance to the Pressure Equipment Directive. The unit is NOT intended for use as an “equipment part with safety function (Art.1, clause 2.1.3). If the units should be used as „equipment part with safety function" please contact the manufacturer.

* Not all approvals are available with all models, see selection list for more information

** Relevant information for use in applications with WHG/VLAREM: see external documentation "Technical Description" and notes to Proof Test on page 41

Mechanical installation

! General Safety Instructions

Process pressure	Improper installation may result in loss of process pressure. Observe possible pressure limitation from the used flange type or in case of use of the sliding sleeve (CN 7130).
Chemical resistance against the medium	Materials of construction are chosen based on their chemical compatibility (or inertness) for general purposes. For exposure to specific environments, check with chemical compatibility charts before installing.
Fastening of the threaded process connection	Mounting torque for the thread may not exceed 40 Nm (metal thread)/ 20 Nm (plastic thread). Use a open-end wrench. Do not fasten by turning the housing, for this will destroy the unit.
EHDG approval/ Food grade material	The materials are available for the use under normal and predictable applications (according to directive 1935/2004 Art.3). Other conditions can influence the safety.

! General Mounting instructions

Handling precautions To prevent damage of the pipe extension, all CN 7130 units with a pipe longer than 2 m (6.5 ft), must be supported at these three points when lifting from a horizontal position

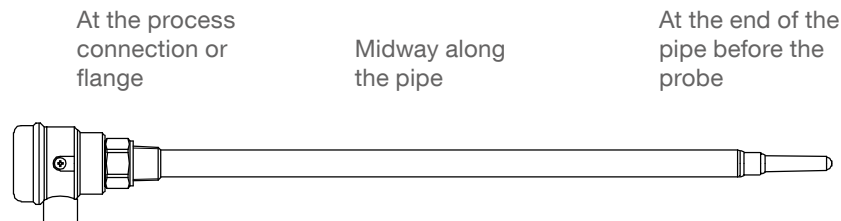

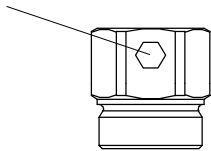
Sliding sleeve	Tighten both straining screws with 15 Nm to obtain resistance against pressure	
Direction of the cable glands (enclosure Ø65mm)	When the unit is mounted from the side, ensure, that the cable glands face downwards and are closed to avoid water penetration into the housing. The enclosure can be rotated against the process connection after mounting.	
Sealing	Ensure proper seal of the process connection thread in case of process pressure.	
Hygienic process connection	Observe that the correct "On site process connection" is present, see page 9.	

Mechanical installation - Liquid applications

Liquid applications - Mounting instructions

CN 7120 /
 CN 7121

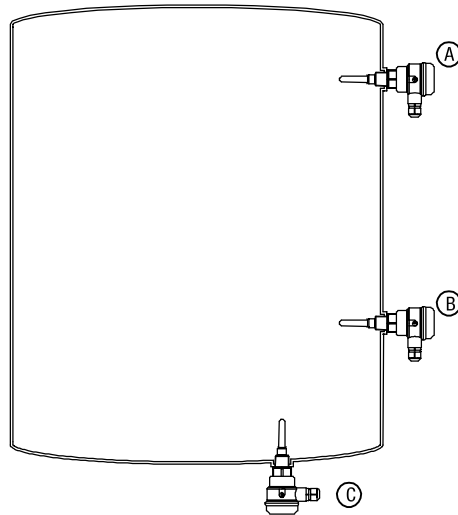

CAUTION

Observe:

- General distances of the probe (see page 19)
- Distance to material flow (filling)
- Max. permitted mechanical load (see page 14)

Vertical vessel

- A** Full detector horizontal
- B** Demand or empty detector horizontal
- C** Empty detector vertical from the bottom

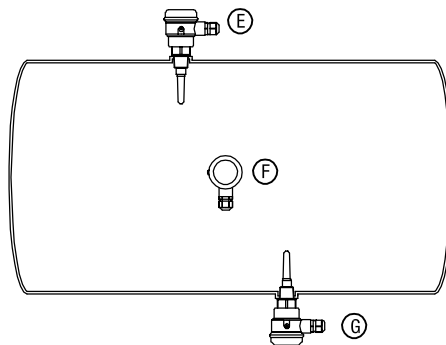

Horizontal vessel

- E** Full detector vertical
- F** Demand or empty detector horizontal
- G** Empty detector vertical from the bottom

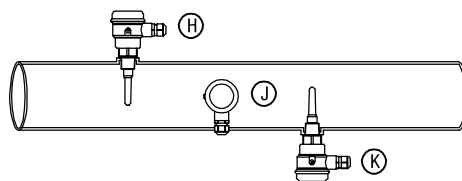

Horizontal pipe

- H** Full detector vertical
- J** Demand or empty detector horizontal
- K** Empty detector vertical from the bottom

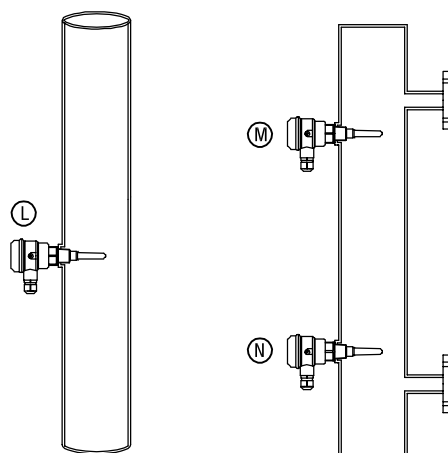

Vertical pipe

- L** Full, demand or empty detector horizontal

Bypass

- M** Full detector horizontal
- N** Demand or empty detector horizontal

Mechanical installation - Liquid applications

CN 7130

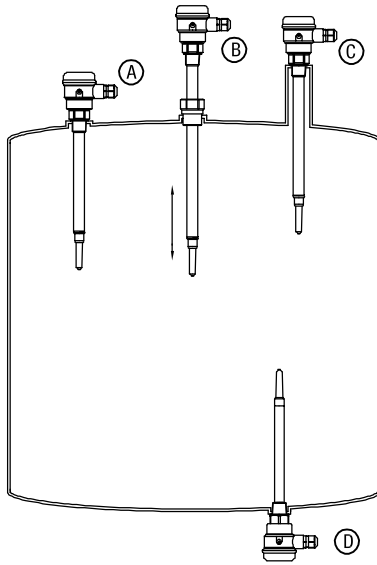

CAUTION

Observe:

- General distances of the probe (see page 19)
- Distance to material flow (filling)
- Max. permitted mechanical load (see page 14)

Vertical vessel

Full, demand or empty detector:

- A** Vertical
- B** Vertical with sliding sleeve
- C** Vertical with long mounting socket
- D** Vertical from bottom

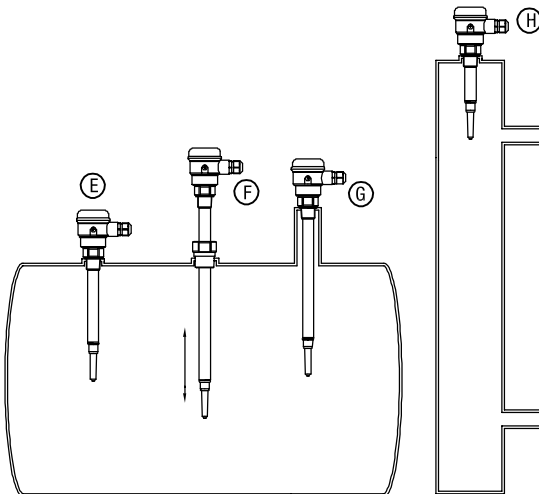

Horizontal vessel

- E** Full, demand or empty detector vertical
- F** Vertical with sliding sleeve
- G** Vertical with long mounting socket

Bypass

- H** Full, demand or empty detector vertical

Mechanical installation - Liquid applications

CN 7150

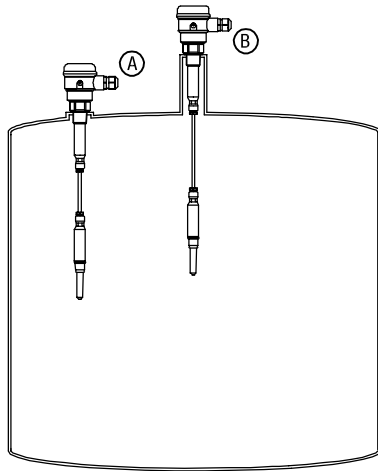

CAUTION

Observe:

- Distance of the probe to the vessel wall (see page 19).
 Consider that the hanging probe can move sideways with material movement.
- Distance to material flow (filling).
- Max. permitted mechanical traction (see page 14).

Vertical vessel

Full, demand or empty detector:

- A** Vertical
- B** Vertical with long mounting socket

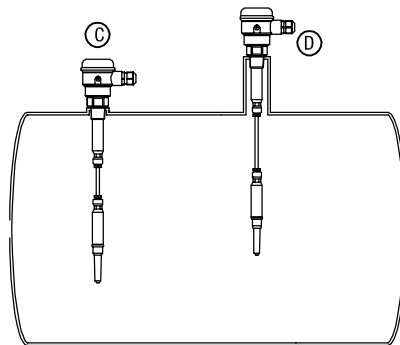

Horizontal vessel

Full, demand or empty detector:

- C** Vertical
- D** Vertical with long mounting socket

Distances of the probe

Observe socket length

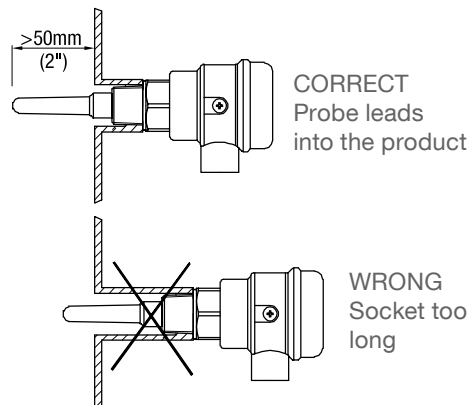

Observe min. distance

- between two probes
- to metal vessel wall

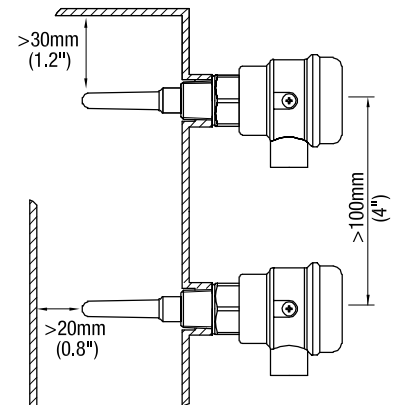

Mechanical installation - Solid applications

Solid applications - Mounting instructions

CN 7120 /
 CN 7121

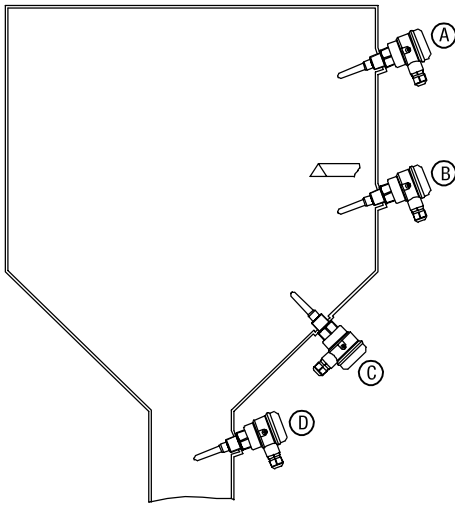

CAUTION

Observe:

- General distances of the probe (see page 21)
- Distance to material flow (filling)
- Max. permitted mechanical load (see page 14)
- Wearing due to abrasive bulk material

- A** Full detector horizontal or oblique.
 Slight incline mounting helps remaining material to fall off more easily
- B** Demand or empty detector horizontal or oblique.
 Slight incline mounting helps remaining material to fall off more easily. Protective angle recommended depending on load and abrasion of the material
- C** Empty detector oblique from the bottom
- D** Empty detector in the silo outlet

CN 7130

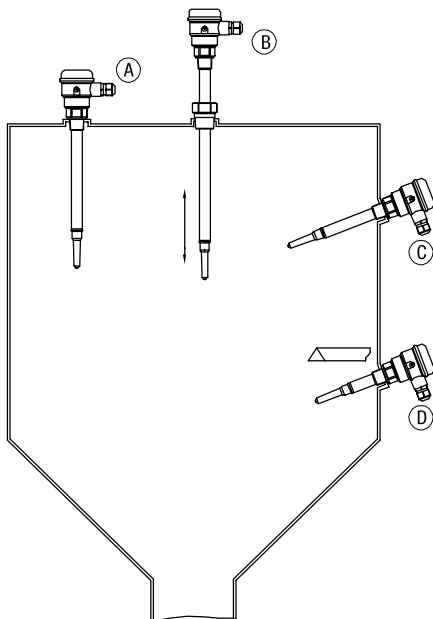

CAUTION

Observe:

- General distances of the probe (see page 21)
- Distance to material flow (filling)
- Max. permitted mechanical load (see page 14)
- Wearing due to abrasive bulk material

- A** Full detector vertical
- B** Full detector with sliding sleeve
- C** Full detector horizontal or oblique. Slight incline mounting helps remaining material to fall off more easily
- D** Demand or empty detector horizontal or oblique.
 Slight incline mounting helps remaining material to fall off more easily. Protective angle recommended depending on load and abrasion of the material

CN 7150

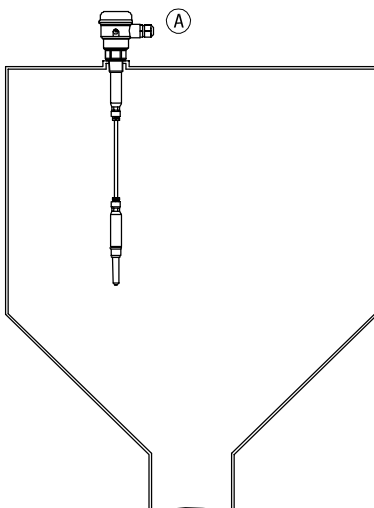

CAUTION

Observe:

- Distance of the probe to the silo wall (see page 21)
 Consider that the hanging probe can move sideways with material
- Distance to material flow (filling)
- Max. permitted mechanical traction (see page 14).
 Empty detector: Do not install in the center of the silo due to high traction with moving material
- Wearing due to abrasive bulk material

- A** Full, demand or empty detector vertical

Mechanical installation - Solid applications

Distances of the probe

Observe socket length

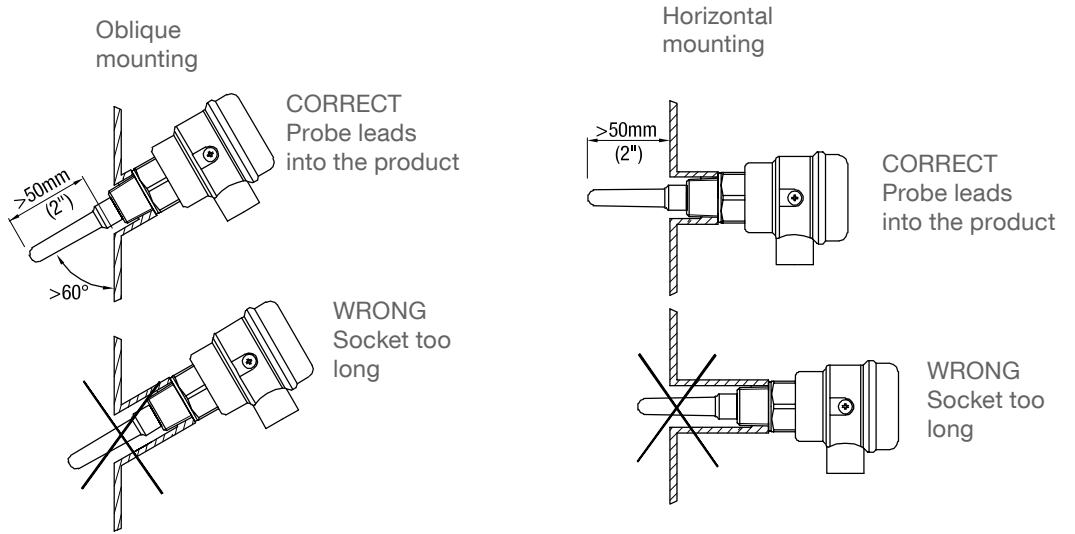

Observe mounting angle to ensure, that the active tip of the probe has enough distance to the metal silo wall

Observe min. distance

- between two probes
- to metal vessel wall
- to protective angle

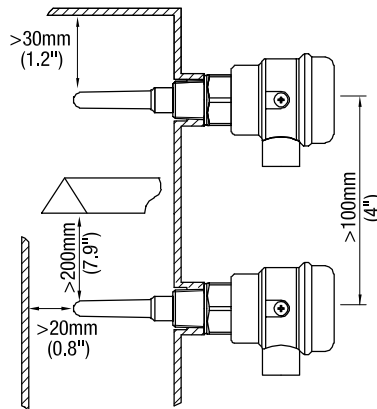

Electrical installation

! General Safety Instructions

Handling	In the case of inexpert handling or handling malpractice the electric safety of the device cannot be guaranteed.
Installation regulations	The local regulations or VDE 0100 (Regulations of German Electro technical Engineers) must be observed.
Power supply switch	A power-supply-disconnecting switch must be provided and marked near the device.
Wiring diagram	The electrical connections have to be made according to the wiring diagram.
Supply voltage	<p>Compare the supply voltage applied with the specifications given on the name plate before switching the device on.</p> <p>The unit must be supplied from a SELV source providing electrical isolation between the input and output, in order to meet the applicable safety requirements of IEC 61010-1.</p> <p>Observe reduced supply voltage ratings in wet locations. A wet location is a location where water or other conductive liquid may be present and is likely to increase the risk of electric shock.</p>
Cable gland and Field wiring cables	<p>With use of terminal block and cable gland: The screwed cable gland must have following specifications:</p> <ul style="list-style-type: none"> • Ingress protection IP68 • Temperature range from -40°C to 10 K above max. ambient temperature • UL or VDE certified (depending on the country where the unit is installed) • Pull relief <p>Make sure that the screwed cable gland safely seals the cable and that it is tight (danger of water intrusion).</p> <p>The field wiring cables must have following specifications:</p> <ul style="list-style-type: none"> • The diameter has to match to the clamping range of the used cable gland. • The cross section has to match with the clamping range of the connection terminals and consider the max. current. • The temperature rating must be at least 10 K above max. ambient temperature. <p>Cut the field wiring cables to appropriate length to fit properly into the housing.</p>
M12 mating plug and Field wiring cables	<p>With use of M12 plug: The mating plug must have following specifications</p> <ul style="list-style-type: none"> • M12x1 according to IEC 61076-2-101, female, 4-pole, coding A-standard • Ingress protection IP68 • Temperature range from -40°C to 10 K above max. ambient temperature <p>The field wiring cables must have following specifications:</p> <ul style="list-style-type: none"> • The diameter and cross section has to match to the specification of the mating plug. • The temperature rating must be at least 10 K above max. ambient temperature. • Install the field wiring cables according to the instructions of the mating plug
Relay protection	Provide protection for relay contacts / solid state relay against spikes with inductive loads
Protection against static charging	<p>The unit must be earthed in any case to avoid static charging of the unit, especially on applications with pneumatic conveying.</p> <p>For Non-Ex units: Functional earthing is satisfactory, see page 23.</p> <p>For Ex-units: The external equipotential bonding terminal must be connected to ground, see page 25.</p>

Electrical installation

Functional earthing

The unit must have connection to earth for proper functioning. This can be done by one of the following possibilities:

Earthing through metal process connection

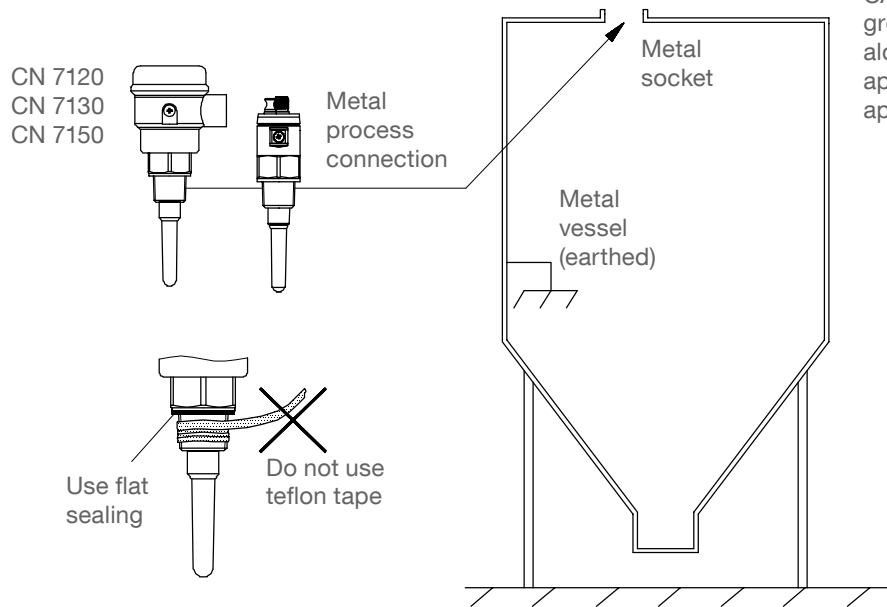

Earthing through external equipotential bonding terminal

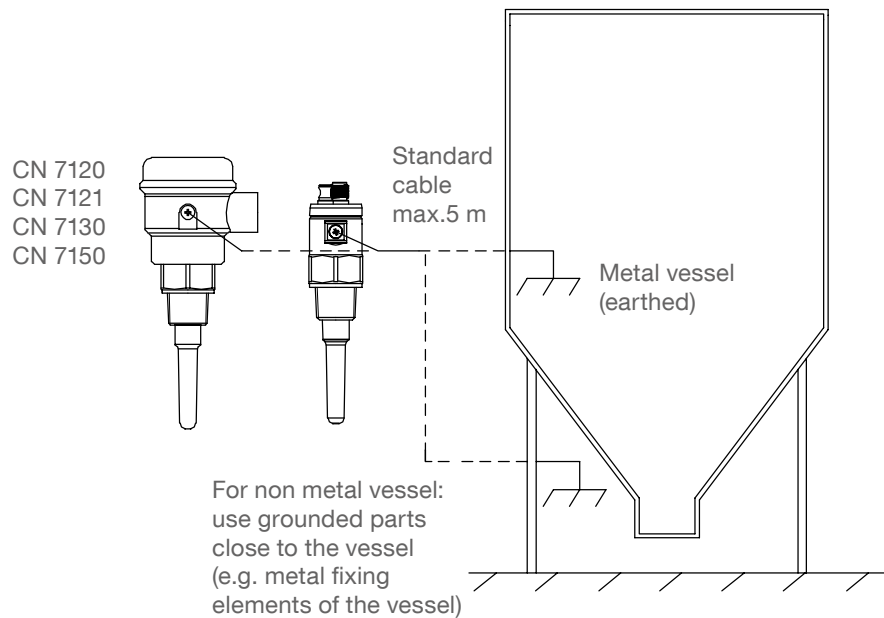

Electrical installation

Standard version (General Purpose)

4-wire operation with DC supply and relay (signal output)

Power supply:
 9 .. 33 V DC, 0,7W
 incl. 10% of EN 61010-1

Signal output:
 Floating relay SPST

Max. 60 V DC or 30 V AC;
 Limited to 35 V DC or 16 V AC in wet locations
 Max. 1 A, 60 W

External fuse:
 max.1A, fast or slow, HBC, 250V

Protection of Relay contact:
 Observe a protection diode in case of connecting an inductance (e.g. external relay)

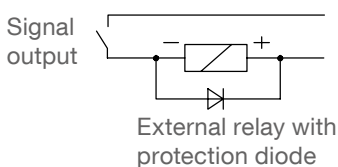

Terminal block

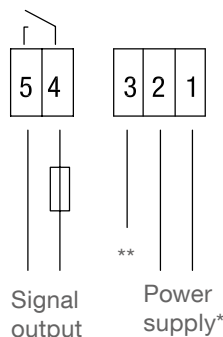

M12 plug

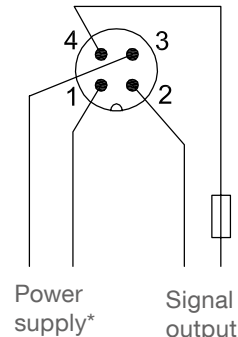

* Polarity determines output logic, see table page 26
 ** See "cable shield" below

2-wire operation with 8/16 mA loop

8/16 mA loop:
 9 .. 33 V DC, 0,7W
 incl. 10% of EN 61010-1

External resistor in loop:
 The above stated voltage is the resulting voltage on the unit. Any voltage drop on an external series resistance must be considered.
 $R_{max} = (V_{supply} - 9 V) / 16 \text{ mA}$
 Example: 24 V supply allows R_{max} of 938 Ohms

Terminal block

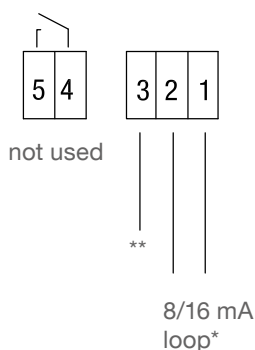

M12 plug

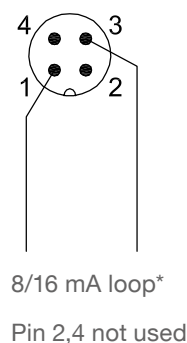

* Polarity determines output logic, see table page 26
 ** See "cable shield" below

Cable shield

It is recommended to use a shielded cable for stable measurement.

With Terminal block: The cable shield can be connected either to terminal 3 or on the other side to earth. Do not connect both sides of the shield to earth. Note: terminal 3 is internal connected to the external equipotential bonding terminal on the enclosure.

With M12 plug: With use of common M12 cables, the cable shield is connected with the M12 cap nut. Since the M12 thread on CN7 is made of plastics, the cable shield on the M12 cap nut is not connected with CN7 and must be connected on the other side to ground.

Electrical installation

Intrinsically safe version

2-wire operation 8/16 mA loop:
with 8/16 mA loop 10.8 .. 30 V DC, 0,7W
 incl. 10% of EN 61010-1

Intrinsically safe supply required (barrier or signal conditioning instruments):

$U_i=30\text{ V}$ $I_i=160\text{ mA}$ $P_i=0,8\text{ W}$,
 $C_i=7,6\text{ nF}$ $L_i=0,3\text{ mH}$

External resistor in loop:

The above stated voltage is the resulting voltage on the unit. Any voltage drop on an external series resistance must be considered.

$R_{\text{max}} = (V_{\text{supply}} - 10.8\text{ V}) / 16\text{ mA}$

Example: 24 V supply allows R_{max} of 825 Ohms

Terminal block

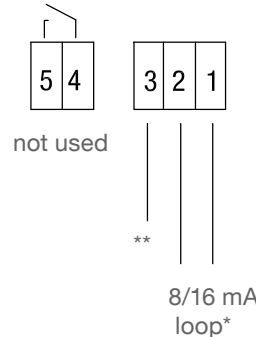

M12 plug

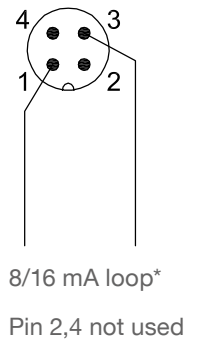

* Polarity determines output logic, see table page 23
 ** See "cable shield" below

4-wire operation with DC supply and solid state relay (signal output) This operation is only available for CN 7120/7121 with enclosure Ø65mm and connection via terminal block (Solid state relay integrated).

Power supply:
 10.8 .. 30 V DC, 0,7W
 incl. 10% of EN 61010-1

Intrinsically safe barrier required:

$U_i=30\text{ V}$ $I_i=160\text{ mA}$ $P_i=0,8\text{ W}$, $C_i=7,6\text{ nF}$ $L_i=0,3\text{ mH}$

Signal output:

Solid state relay
 Max. switching voltage / current: 30 V DC / 82mA

For connection to an intrinsically safe "switch amplifier for contact input" or to an intrinsically safe PLC with integrated input card for contact input.

$U_i=30\text{ V}$ $I_i=200\text{ mA}$ $P_i=350\text{ mW}$, $C_i=4,2\text{ nF}$ $L_i=0$

Terminal block

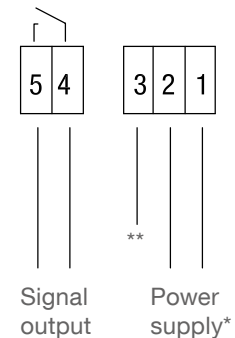

* Polarity determines output logic, see table page 23
 ** See "cable shield" below

External equipotential bonding terminal

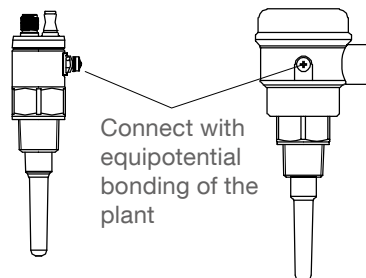

Cable shield

It is recommended to use a shielded cable for stable measurement.







With Terminal block: The cable shield can be connected either to terminal 3 or on the other side to earth. Do not connect both sides of the shield to earth. Note: terminal 3 is internal connected to the external equipotential bonding terminal on the enclosure.

With M12 plug: With use of common M12 cables, the cable shield is connected with the M12 cap nut. Since the M12 thread on CN7 is made of plastics, the cable shield on the M12 cap nut is not connected with CN7 and must be connected on the other side to ground.

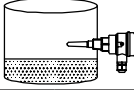
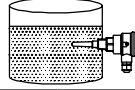
Electrical installation







Output logic

Terminal block

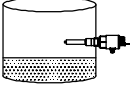
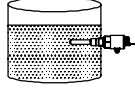
					Fault
White LED	●		☀		☉ 2Hz
Setting	FSL	FSH	FSL	FSH	n.a.
Supply polarity Terminal 1 Terminal 2	L+ L-	L- L+	L+ L-	L- L+	n.a.
Yellow LED	●	☀	☀	●	●
Relay (Terminal 4+5)					
8/16 mA loop (Terminal 1+2)	8 mA	16 mA	16 mA	8 mA	3,6 mA

FSL = Fail safe low FSH = Fail safe high

M12 plug

					Fault
White LED	●		☀		☉ 2Hz
Setting	FSL	FSH	FSL	FSH	n.a.
Supply polarity M12, Pin 1 M12, Pin 3	L+ L-	L- L+	L+ L-	L- L+	n.a.
Yellow LED	●	☀	☀	●	●
Relay (M12, Pin 2+4)					
8/16 mA loop (M12, Pin 1+3)	8 mA	16 mA	16 mA	8 mA	3,6 mA

FSL = Fail safe low FSH = Fail safe high

Electrical installation

FM / CSA Approval - Connection drawing

FM / CSA Class I, II, III Div.1, Group A-G

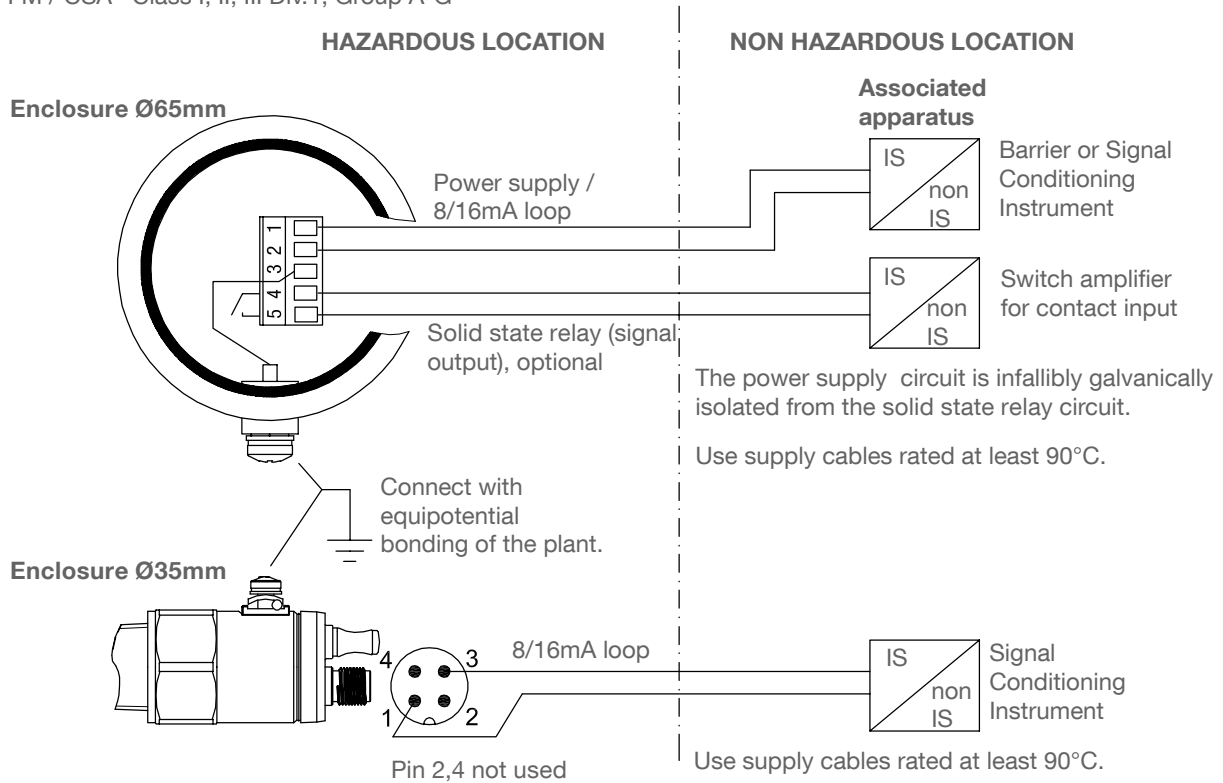

For use at altitude ≤ 2000m:

Ambient temperature range	Process temperature range	Max. Surface temperature	Temperature class
-40 .. +50°C (-40 .. +122°F) (1)	-40 .. +50°C (-40 .. +122°F) (1)	80°C	T6
-40 .. +65°C (-40 .. +149°F) (1)	-40 .. +65°C (-40 .. +149°F) (1)	95°C	T5
-40 .. +85°C (-40 .. +185°F) (1)	-40 .. +100°C (-40 .. +212°F) (1)	130°C	T4
-40 .. +85°C (-40 .. +185°F) (1)	-40 .. +125°C (-40 .. +257°F) (1)	155°C	T3

(1) With option FFKM O-ring seal: Lower ambient and process temperature limited to -20°C (-4°F)

For use at altitude > 2000m ... ≤ 3000m:

Ambient temperature range	Process temperature range	Max. Surface temperature	Temperature class
-40 .. +45°C (-40 .. +113°F) (1)	-40 .. +45°C (-40 .. +113°F) (1)	80°C	T6
-40 .. +58°C (-40 .. +136°F) (1)	-40 .. +58°C (-40 .. +136°F) (1)	95°C	T5
-40 .. +76°C (-40 .. +168°F) (1)	-40 .. +90°C (-40 .. +194°F) (1)	130°C	T4
-40 .. +76°C (-40 .. +168°F) (1)	-40 .. +112°C (-40 .. +233°F) (1)	155°C	T3

(1) With option FFKM O-ring seal: Lower ambient and process temperature limited to -20°C (-4°F)

Electrical installation

Entity parameters:

Power supply / 8/16mA loop: $U_i=30\text{ V}$ $I_i=160\text{ mA}$ $P_i=0,8\text{ W}$, $C_i=7,6\text{ nF}$ $L_i=0,3\text{ mH}$
Solid state relay: $U_i=30\text{ V}$ $I_i=200\text{ mA}$ $P_i=350\text{ mW}$, $C_i=4,2\text{ nF}$ $L_i=0$

Associated apparatus:

The Associated apparatus must have ratings as follows:

Max. output voltage U_o or V_{oc} or $V_t < U_i$
Max. output current I_o or I_{sc} or $I_t < I_i$
Max. output power $P_o < P_i$
Max. allowed capacitance C_o or $C_a > C_i + C_{cable}$
Max. allowed inductance L_o or $L_a > L_i + L_{cable}$

Observe installation manual of the manufacturer of the Associated apparatus.

For FM:

Use a FM certified intrinsic safe Associated Apparatus. Installation must be in accordance with the National Electrical Code (NFPA 70, articles 504 and 505) and ANSI/ISA RP 12.06.01.

For CSA:

Use a CSA certified intrinsic safe Associated Apparatus. Installation must be in accordance with the Canadian Electrical Code.

Notes for use in Hazardous Locations

Use of this Manual

For use and assembly, refer to the instructions in this Manual. It does contain all instruction as required by ATEX Directive 2014_34_EU, Annex II, 1/0/6 and Ordinance INMETRO n° 179/2010

General notes

Refer to appropriate certificate for application in specific hazardous environment.

The equipment has not been assessed as a safety related device (as referred to by Directive 2014_34_EU Annex II, clause 1.5).

The certificate numbers have an 'X' suffix, which indicates that specific condition of use apply. Those installing or inspecting this equipment must have access to the certificates.

! Qualification of personnel / Servicing / Repair

Installation and inspection of this equipment shall be carried out by suitably trained personnel in accordance with the applicable code of practice.

Repair of this equipment shall be carried out by suitably trained personnel in accordance with the applicable code of practice.

Components to be incorporated into or used as replacements in the equipment shall be fitted by suitably trained personnel in accordance with the manufacturer's documentation.

Turn off power before servicing any device (the transmitter is in operation when the power supply is switched on). In case of removing the unit from vessel, take care of process pressure and material passing the opening.

Certificates / List of Standards

See www.uwtgroup.com for the latest certificates

See EU - Declaration of conformity for the list of standards valid for ATEX certificates

Year of manufacturing

Marking on the name plate is done according to IEC 60062 as follows:

Year of manufacturing	2020	2021	2022	2023	2024	2025	2026	2027	2028	2029
Marking code	M	N	P	R	S	T	U	V	W	X

Notes for use in Hazardous Locations

! Permitted zones for installation

Devices can be installed as follows:

	Dust applications		Gas applications	
	Marking Da/Db	Marking Ga/Gb	Marking Ga	
EPL	Db	Gb	Ga	
Category	2D	2G	1G	
Zone	21	1	0	
<hr/>				
EPL	Da	Ga	Ga	
Category	1D	1G	1G	
Zone	20	0	0	

Not all approvals are available with all models, see selection list for more information

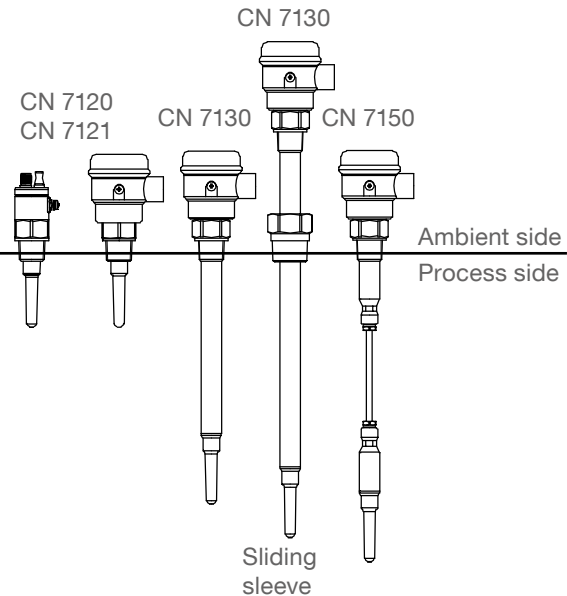

! Warnings for installation

Intrinsically safe supply For intrinsically safe models, power must be supplied from an Intrinsically Safe power source, otherwise protection is no longer guaranteed.

Process pressure Devices with Ex Approval are approved for atmospheric pressure. A detailed explanation is given below for ATEX and applies analogously for other Ex approvals:
 The scope of the ATEX directive is generally limited to atmospheric pressure, see ATEX directive 2014_34_EU Chapter 1 Art.2 (4). Atmospheric pressure is defined as absolute pressure 0.8bar to 1.1bar, see ATEX guideline §50 and IEC 60079-0 chapter 1 Scope. The technical background is that an explosive atmosphere which is compressed (overpressure) or released (underpressure) can exhibit different explosion behaviour than under atmospheric conditions.
 The standards for the types of protection against explosion (IEC 60079 series), on which a type approval according to the ATEX directive is based, are designed for atmospheric conditions and do not automatically cover deviating pressure conditions.
 Thus, an ATEX type approval issued in accordance with this directive only covers atmospheric pressure.
 This applies to all manufacturers.
 A deviating operating pressure can be assessed and approved by an expert for the respective application.
 Regardless of this, the design of the level indicators is suitable for a vessel overpressure / underpressure in accordance with the specified technical data.

Chemical resistance against the medium If the equipment is likely to come into contact with aggressive substances, then it is the responsibility of the user to take suitable precautions that prevent it from being adversely affected, thus ensuring that the type of protection is not compromised. Aggressive substances: e.g. acidic liquids or gases that may attack metals, or solvents that may affect polymeric materials. Suitable precautions: e.g. establishing from the material's data sheet that it is resistant to specific chemicals.

Notes for use in Hazardous Locations

Versions with cable gland mounted by default

Below-mentioned cable diameters and tightening torques of the nut shall be observed for the installation.

Cable gland: M20x1.5

Cable diameter: 6 mm to 12 mm

Tightening torque: Depending on the used cable and therefore to be determined by the user.



Specific conditions of use

Electrostatic charge

For gas- and dust-explosive atmospheres:

The apparatus shall be installed in a way that electrostatic charging hazards on non-metallic parts outside the process can be excluded.

For gas-explosive atmospheres only:

The apparatus shall be installed in a way that electrostatic charging hazards on non-metallic parts inside the process can be excluded.

Applications Ga/Gb or Da/Db

The installation of the apparatus into the separation wall shall be in a way that technical tightness on the process connection is ensured.

The apparatus shall only be used in process media for which the chemical resistance of the materials, which are in contact with the process media, is ensured.

The materials which are in contact with the process media are defined by positions 6 and 7 of the type code.

Intrinsic safety

For dust-explosive atmospheres only:

The intrinsically safe circuits of the apparatus shall be regarded as grounded in the event of a fault. To avoid danger from circulating fault currents, appropriate measures, acc. to IEC / EN 60079-14 and depending on the installation shall be considered (e. g. equipotential bonding along the intrinsically safe circuits).

Ambient and process temperature range

The relation between ambient temperature range, process temperature range and temperature class (for gas) or maximum surface temperature (for dust) is shown in the thermal parameters table.

With option FFKM O-ring seal lower ambient temperature range and lower process temperature range are limited to -20°C (-4°F).
 Details see next page.

Max. permitted temperature close to the enclosure

If the process temperature exceeds the permissible ambient temperature, the max. resulting temperature close to the enclosure (see dotted line) shall not exceed the related max. permissible ambient temperature (see next page), taking the worst case conditions into account.

This shall be verified by measurement when installed.

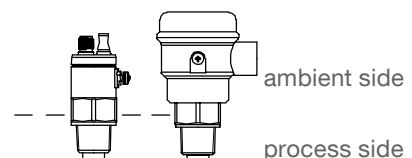

Notes for use in Hazardous Locations

- ! Ambient and process temperature range,
- max. Surface Temperature and Temperature Class

The temperature marking on the type plate  refers to the instruction manual.
 In the following tables the relevant temperature ratings are shown.

For use at altitude ≤ 2000 m:

Ambient temperature range	Process temperature range	Max. Surface temperature (EPL Da or Db)	Temperature class (EPL Ga or Gb)
-40 .. +50°C (-40 .. +122°F) (1)	-40 .. +50°C (-40 .. +122°F) (1)	T ₂₀₀ 80°C	T6
-40 .. +65°C (-40 .. +149°F) (1)	-40 .. +65°C (-40 .. +149°F) (1)	T ₂₀₀ 95°C	T5
-40 .. +85°C (-40 .. +185°F) (1)	-40 .. +100°C (-40 .. +212°F) (1)	T ₂₀₀ 130°C	T4
-40 .. +85°C (-40 .. +185°F) (1)	-40 .. +125°C (-40 .. +257°F) (1)	T ₂₀₀ 155°C	T3

(1) With option FFKM O-ring seal: Lower ambient and process temperature limited to -20°C (-4°F)

For use at altitude > 2000 m ... ≤ 3000m:

Ambient temperature range	Process temperature range	Max. Surface temperature (EPL Da or Db)	Temperature class (EPL Ga or Gb)
-40 .. +45°C (-40 .. +113°F) (1)	-40 .. +45°C (-40 .. +113°F) (1)	T ₂₀₀ 80°C	T6
-40 .. +58°C (-40 .. +136°F) (1)	-40 .. +58°C (-40 .. +136°F) (1)	T ₂₀₀ 95°C	T5
-40 .. +76°C (-40 .. +168°F) (1)	-40 .. +90°C (-40 .. +194°F) (1)	T ₂₀₀ 130°C	T4
-40 .. +76°C (-40 .. +168°F) (1)	-40 .. +112°C (-40 .. +233°F) (1)	T ₂₀₀ 155°C	T3

(1) With option FFKM O-ring seal: Lower ambient and process temperature limited to -20°C (-4°F)

Operation

Operation - Operating elements / LED's

Operating elements

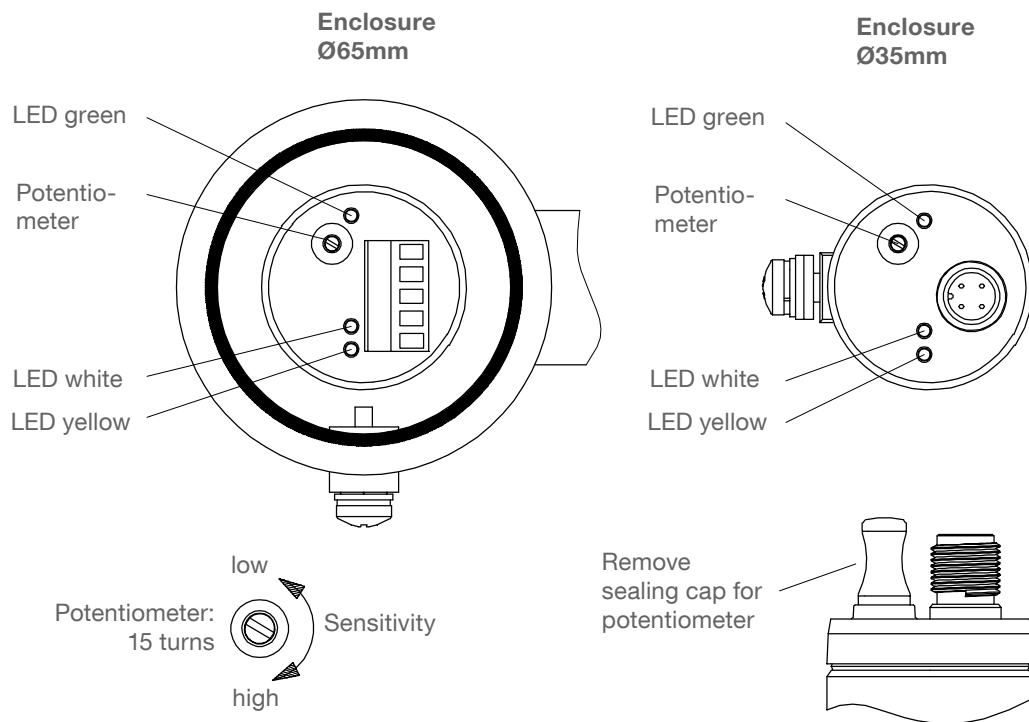

LEDs

Green	ON		Power on
	OFF		Power off
Yellow	ON		Current loop: 16mA Relay: activated
	OFF		Current loop: 8mA Relay: idle
	Blinks for a few times, then stops blinking		The number of blinks indicates the position of the potentiometer after it was turned (see page 39)
White	ON		Unit indicates covered Capacitance on probe > setted switchpoint
	OFF		Unit indicates uncovered Capacitance on probe < setted switchpoint
	Blinks slowly (every 2 seconds)		Potentiometer is on the max. sensitive position (max. clockwise stop), the 4-20mA continuous mode is active (see page 40)
	Blinks fast (twice per second)		Diagnostics has indicated a failure

Operation - Factory calibration

Switchpoint factory calibration - General applications

Application Factory calibration is applicable for general applications.

Typical general application	On site calibration
<ul style="list-style-type: none"> • Low viscosity liquids • Water based liquids • High conductivity liquids without buildup • Dry solids 	Not required

Switchpoint with factory calibration The unit is factory calibrated to measure dielectric constant of material ≥ 2.0 . With factory calibration the probe must be covered with a certain height of material in order to switch from uncovered to covered (switchpoint), as follows:

Dielectric constant of measured material	Probe horizontal A	Probe vertical B
< 2.0	not possible with factory calibration	
2.0	5mm (0.2")	20mm (0.8")
2.0 ... 3.0	0mm (0.0")	15mm (0.6")
3.0 ... 5	-5mm (-0.2")*	8mm (0.3")
5 ... 10	-8mm (-0.3")*	5mm (0.2")
>10 ... 40	-10mm (-0.4")*	3mm (0.1")

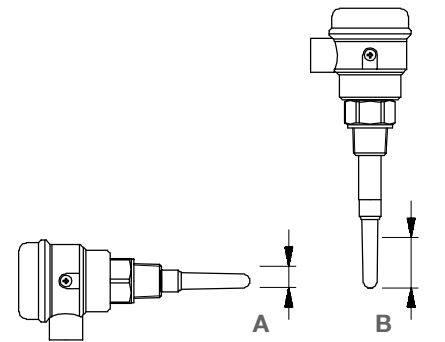

Switchpoint
(coverage with material)

* Switchpoint is below the probe (material not touching the probe).

The stated values are valid under following conditions:

- The distance of the probe to a metal wall is not smaller than stated on page 19 and 21.
- The Sensguard (see page 12) is not used.
- Conductive material is not present.

Note The active shield technology in combination with the length of the probe, resulting in adequate distance between internal measurement electrode and ground electrode, reduces the influence of various measured capacitance due to the mounting situation and of moderate material buildup. As a result, no on site calibration is required for general applications.

Operation - Recalibration

Switchpoint setting - In case of recalibration or if factory calibration is not applicable

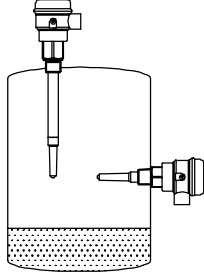
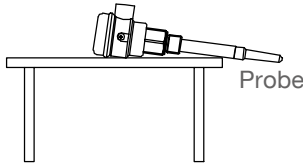
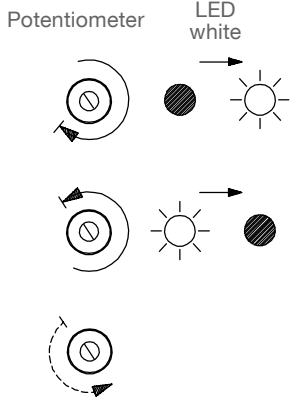
<p>1. Ensure that the probe is uncovered</p>	<p>The unit will calibrate to an uncovered probe.</p> <div style="display: flex; justify-content: space-around;"> <div style="text-align: center;">  <p>Setting with mounted sensor:</p> <p>Ensure material level is well below the probe</p> </div> <div style="text-align: center;">  <p>Setting on the bench:</p> <p>Take care not to touch the probe and keep the probe at least 200mm away from any material (for example table)</p> </div> </div>										
<p>2. Set switchpoint with potentiometer</p>	<p>Note: 1 second after stopping to turn the potentiometer, the yellow LED blinks for a few times, then stops blinking. This allows to identify the position of the potentiometer which enables more easy service in case external technicians are contacted. Details see page 39.</p> <p>If LED white is OFF, turn clockwise until LED white is ON.</p> <p>Turn counter clockwise until LED white just stops glowing.</p> <p>Turn further counter clockwise:</p> <table border="1" data-bbox="507 1323 892 1550"> <thead> <tr> <th>Dielectric constant of material</th> <th>Number of turns</th> </tr> </thead> <tbody> <tr> <td>1.6 .. 2</td> <td>1</td> </tr> <tr> <td>2 .. 3</td> <td>2</td> </tr> <tr> <td>3 .. 4</td> <td>3</td> </tr> <tr> <td>>4</td> <td>4</td> </tr> </tbody> </table> <p>The stated values assume, that the distance of the probe to a metal wall is not smaller than stated on page 19 and 21 and that the Sensguard (see page 12) is not used. Depending on the application and the required switchpoint the number of turns can be varied.</p> <div style="text-align: right; margin-top: 20px;"> <p>Potentiometer LED white</p>  </div>	Dielectric constant of material	Number of turns	1.6 .. 2	1	2 .. 3	2	3 .. 4	3	>4	4
Dielectric constant of material	Number of turns										
1.6 .. 2	1										
2 .. 3	2										
3 .. 4	3										
>4	4										
<p>Switchpoint setting is finished</p>											

Operation- Advanced calibration

Operation - Advanced calibration

Switchpoint setting - Demanding Applications

Typical demanding application	On site calibration
<ul style="list-style-type: none"> • Material with heavy buildup (non conductive): • High viscosity liquids • Hygroscopic/ wet solids 	Probe covered and then uncovered, retaining max. possible material buildup
<ul style="list-style-type: none"> • Heavy buildup (conductive) 	Consult manufacturer

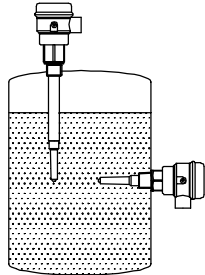
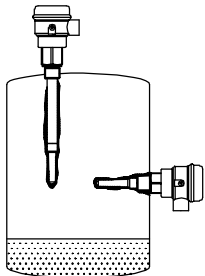
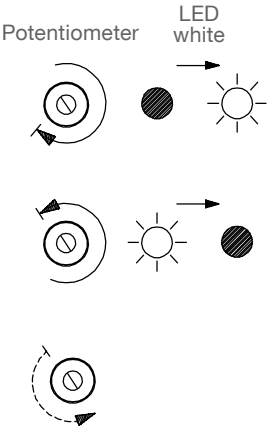
<p>1. Ensure material level is well above the probe</p>											
<p>2. Ensure material level is well below the probe</p>	<p>It is important that as much material buildup as possible is retaining on the probe.</p> 										
<p>3. Set switchpoint with potentiometer</p>	<p>Note: 1 second after stopping to turn the potentiometer, the yellow LED blinks for a few times, then stops blinking. This allows to identify the position of the potentiometer which enables more easy service in case external technicians are contacted. Details see page 39.</p> <p>If LED white is OFF, turn clockwise until LED white is ON.</p> <p>Turn counter clockwise until LED white just stops glowing.</p> <p>Turn further counter clockwise:</p> <table border="1" data-bbox="507 1615 890 1839"> <thead> <tr> <th>Dielectric constant of material</th> <th>Number of turns</th> </tr> </thead> <tbody> <tr> <td>1.6 .. 2</td> <td>1</td> </tr> <tr> <td>2 .. 3</td> <td>2</td> </tr> <tr> <td>3 .. 4</td> <td>3</td> </tr> <tr> <td>>4</td> <td>4</td> </tr> </tbody> </table> <p>The stated values assume, that the distance of the probe to a metal wall is not smaller than stated on page 19 and 21 and that the Sensguard (see page 12) is not used. Depending on the application and the required switchpoint the number of turns can be varied.</p> 	Dielectric constant of material	Number of turns	1.6 .. 2	1	2 .. 3	2	3 .. 4	3	>4	4
Dielectric constant of material	Number of turns										
1.6 .. 2	1										
2 .. 3	2										
3 .. 4	3										
>4	4										
<p>Switchpoint setting is finished</p>											

Operation - Advanced calibration

Switchpoint setting - Interface detection

Typical interface application	On site calibration
<ul style="list-style-type: none"> • Ignoring liquid A/ detecting liquid B • Ignoring foam/ detecting liquid 	Immerse probe in liquid A or foam

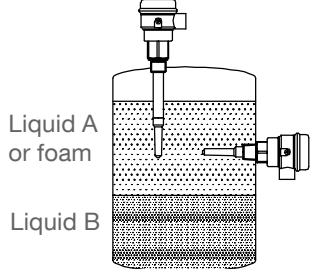
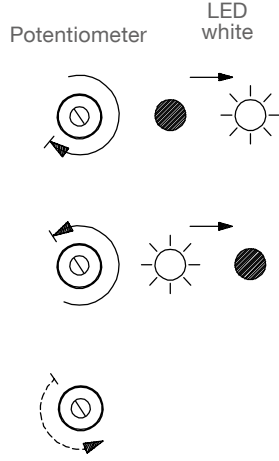
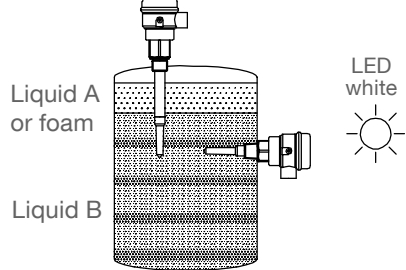
<p>1. Immerse probe in liquid A or in foam which should NOT be detected</p>	<p>Ensure that liquid A or foam (which should NOT be detected) is covering the probe.</p> <p>Liquid A or foam must have a lower dielectric constant than liquid B, which should be detected.</p> <div style="text-align: right;">  </div>						
<p>2. Set switchpoint with potentiometer</p>	<p>Note: 1 second after stopping to turn the potentiometer, the yellow LED blinks for a few times, then stops blinking. This allows to identify the position of the potentiometer which enables more easy service in case external technicians are contacted. Details see page 39.</p> <p>If LED white is OFF, turn clockwise until LED white is ON.</p> <p>Turn counter clockwise until LED white just stops glowing.</p> <p>Turn further counter clockwise:</p> <table border="1" data-bbox="603 1288 986 1433"> <thead> <tr> <th>Dielectric constant of liquid A or foam</th> <th>Number of turns</th> </tr> </thead> <tbody> <tr> <td>≤ 10</td> <td>1</td> </tr> <tr> <td>> 10</td> <td>$\frac{1}{2}$</td> </tr> </tbody> </table> <p>The stated values assume, that the distance of the probe to a metal wall is not smaller than stated on page 19 and 21 and that the Sensguard (see page 12) is not used. Depending on the application and the required switchpoint the number of turns can be varied. The sensitivity is now setted thus that liquid A or foam is NOT detected.</p> <div style="text-align: right;">  </div>	Dielectric constant of liquid A or foam	Number of turns	≤ 10	1	> 10	$\frac{1}{2}$
Dielectric constant of liquid A or foam	Number of turns						
≤ 10	1						
> 10	$\frac{1}{2}$						
<p>3. Immerse probe in liquid B which should be detected</p>	<p>Ensure that liquid B (which should be detected) is covering the probe.</p> <p>LED white should glow.</p> <div style="text-align: right;">  </div>						
<p>Switchpoint setting is finished</p>							

Operation - Advanced calibration

Switchpoint setting - Measurement through non metal vessel wall

Typical application	On site calibration
• Measuring through non metal vessel wall	Material below probe

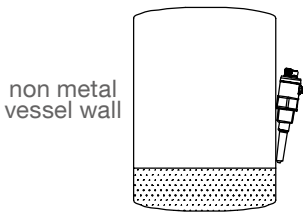
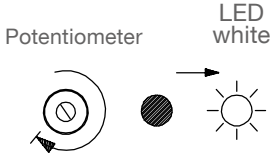
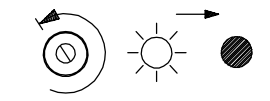
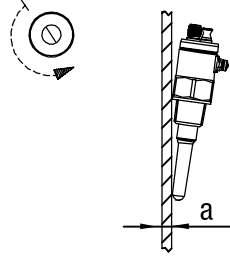
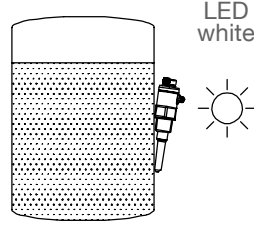
<p>1. Ensure material level is well below the probe</p>	<p>The unit will calibrate to an uncovered probe.</p> 									
<p>2. Set switchpoint with potentiometer</p>	<p>Note: 1 second after stopping to turn the potentiometer, the yellow LED blinks for a few times, then stops blinking. This allows to identify the position of the potentiometer which enables more easy service in case external technicians are contacted. Details see page 39.</p> <p>If LED white is OFF, turn clockwise until LED white is ON.</p>  <p>Turn counter clockwise until LED white just stops glowing.</p>  <p>Turn further counter clockwise:</p> <table border="1" data-bbox="502 1332 957 1512"> <thead> <tr> <th>Dielectric constant of material</th> <th>Distance a (material to probe)</th> <th>Number of turns</th> </tr> </thead> <tbody> <tr> <td>≥ 3</td> <td>$\leq 10\text{mm (0.4")}$</td> <td>$\frac{1}{4}$</td> </tr> <tr> <td>> 40</td> <td>$\leq 20\text{mm (0.8")}$</td> <td>$\frac{1}{2}$</td> </tr> </tbody> </table> <p>Depending on the application and the required switchpoint the number of turns can be varied.</p> 	Dielectric constant of material	Distance a (material to probe)	Number of turns	≥ 3	$\leq 10\text{mm (0.4")}$	$\frac{1}{4}$	> 40	$\leq 20\text{mm (0.8")}$	$\frac{1}{2}$
Dielectric constant of material	Distance a (material to probe)	Number of turns								
≥ 3	$\leq 10\text{mm (0.4")}$	$\frac{1}{4}$								
> 40	$\leq 20\text{mm (0.8")}$	$\frac{1}{2}$								
<p>3. Ensure material level is well above the probe</p>	<p>LED white should glow.</p> 									
<p>Switchpoint setting is finished</p>										

Operation - Advanced possibilities

Advanced possibilities

The unit allows following usefull advanced possibilities, which are related to the position of the potentiometer

Indicating the actual position of the potentiometer

1 second after stopping to turn the potentiometer, the yellow LED blinks for a few times, then stops blinking. This allows to identify the actual position of the potentiometer which enables more easy service in case external technicians are contacted.

Note: The signal output (relay, transistor) does not follow the blinking.
 See Table below.

Relation of potentiometer position to sensitivity

The position of the potentiometer is clearly related to the dielectric constant and therefore to the sensitivity of the unit.
 See Table below.

Selected mode	Required min. dielectric constant of material to be detected (1)	Position of the potentiometer = No. of potentiometer turns, see (2) below	Number of blinking of yellow LED, see (3) below
4-20mA continuous mode	not applicable (see next page)	0 ... 2	0
switch mode	1 (Probe in air)	3	1
	1.5	4	2
	2	5	3
	3	6	4
	4	7	5
	6	8	6
	8	9	7
	11	10	7
	15	11	8
	25	12	8
	40	13	9
	60	14	9
	90	15	9

(1) The stated values are valid under following conditions:

- The distance of the probe to a metal wall is not smaller than stated on page 19 and 21.
- The probe is mounted inside the vessel (no measurement from outside through the vessel wall).
- The Sensguard (see page 12) is not used.
- Conductive material is not present.

(2) To set the position of the potentiometer to a certain sensitivity, do following steps:



a) Turn potentiometer clockwise for min. 15 turns, thus stop position is safely reached.



b) Turn potentiometer counter clockwise according to the number of turns stated in the table above.

(3) Yellow LED starts blinking 1 second after stopping to turn the potentiometer.

Operation - Advanced possibilities

4-20mA continuous mode

The output can be set to 4-20 mA continuous mode.
 In this mode the loop current is related to the measured dielectric constant.

This mode allows to improve the safety of measurement in critical or special applications, like:

- Detection of increasing material buildup .
- Detection of small changes of capacitance like material with low dielectric constant or measurement through non metallic walls.
- Understanding the capacitance change happening in certain applications.

The loop current is related to the measured dielectric constant as follows:

- 4mA is related to an uncovered probe in air with dielectric constant = 1 ⁽¹⁾
- 16mA is related to a covered probe with dielectric constant = 90 ^(1, 2)

The stated values are valid under following conditions:

- (1) The distance of the probe to a metal wall is not smaller than stated on page 19 and 21.
- (2) Probe must be covered with enough height of material as stated on page 33.
 The probe is mounted inside the vessel (no measurement from outside through the vessel wall)
 Conductive material is not present

The measured dielectric constant versus loop current / mA is non-linear to ease the reading for high sensitivity applications in material with low dielectric constant.

The mode is selected by turning the potentiometer clockwise for min. 15 turns, until stop position is safely reached (= max. sensitive position). LED white must blink.



Note:

The relay output is not operable with this mode. It is idle.
 The yellow LED is off.

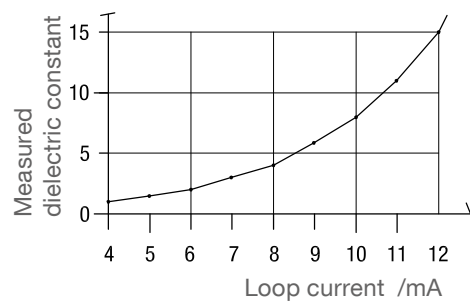
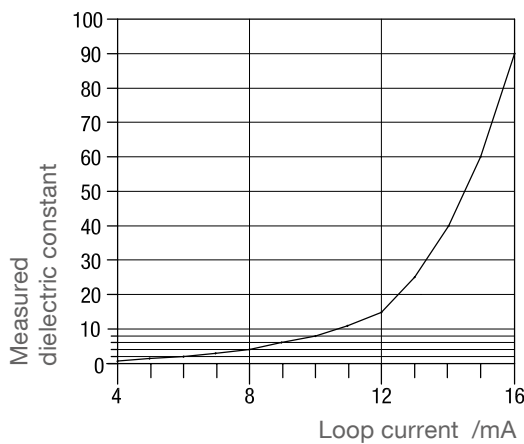

Operation - WHG Proof Test

The implementation of the WHG proof test is done in accordance with the documentation "Technical Description" for WHG, Annex 8, Proof Test, by following possibilities:

Filling the vessel	<ul style="list-style-type: none"> • Filling the vessel until the switchpoint is reached and monitoring the correct reaction of the system
Simulation of the level	<ul style="list-style-type: none"> • Suitable simulation of the level or of the physical measurement effect <p>This can be done for example by dismounting the sensor and immersion into the original medium.</p>
Interruption of the supply voltage	<ul style="list-style-type: none"> • Interruption of the supply voltage of CN 7000 for > 2 sec and monitoring the correct reaction of the system <p>With connection of an additional signal conditioning instrument, which meets the requirements of clause 3 and 4 of the ZG-ÜS.</p> <p>The CN 7000 starts a self diagnostics routine when the power supply is applied with a defined startup behaviour (see page 5). Possible functional failures can be monitored by the reaction of the system.</p>
Pushing the Test Key on a signal conditioning instrument	<ul style="list-style-type: none"> • Pushing the Test Key on a signal conditioning instrument and monitoring the status indicator on the signal conditioning instrument <p>With connection of an additional signal conditioning instrument, which meets the requirements of clause 3 and 4 of the ZG-ÜS.</p> <p>This possibility is described with use of the signal conditioning instrument Siemens Sitrans SCSC or TCSC as follows:</p>

Use of signal conditioning instrument with Test Key: Siemens Sitrans SCSC or TCSC

Sitrans SCSC/TCSC	<p>The signal conditioning instrument is available as single channel SCSC (connection of one CN 7000) or double channel TCSC (connection of two CN 7000).</p> <p>! The operation manual of Sitrans SCSC or Sitrans TCSC is mandatory. Following notes give support for the connection with CN 7000.</p>
--------------------------	--

Function of the Test Key	<p>The Test Key on the Sitrans signal conditioning instrument interrupts the supply voltage of the CN 7000. When the supply voltage is applied, the CN 7000 starts a self diagnostics routine with a defined startup behaviour (see page 5). Possible functional failures will be evaluated by the signal conditioning instrument, which switches to the overflow state and indicates the failure by a LED .</p>
---------------------------------	--

Interaction with CN 7000	<p>The Sitrans signal conditioning instrument is set to Mode "Max. Adjustment" (overflow protection).</p> <p>For a correct interaction with CN 7000 the supply polarity for CN 7000 is set in a way, that the loop current with covered sensor is 16mA (see page 26):</p>
---------------------------------	---

CN 7000	Connection to Sitrans
Terminal 1 / M12 Pin 1	+ Polarity
Terminal 2 / M12 Pin 3	- Polarity
Wiring diagram see next page.	

Operation - WHG Proof Test

Wiring 1-channel unit Sitrans SCSC

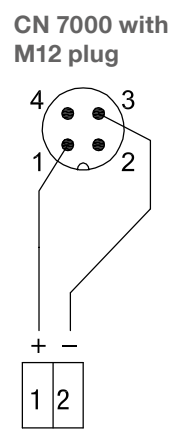
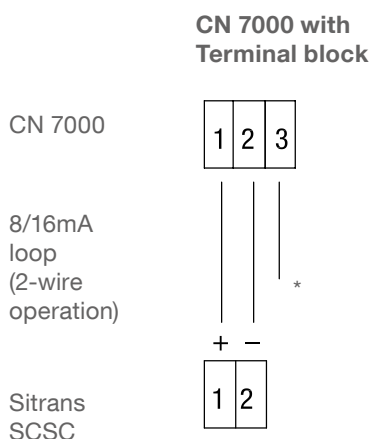

* Cable shield, see page 24

Wiring 2-channel unit Sitrans TCSC

Two CN 7000 units can be connected to Sitrans TCSC:

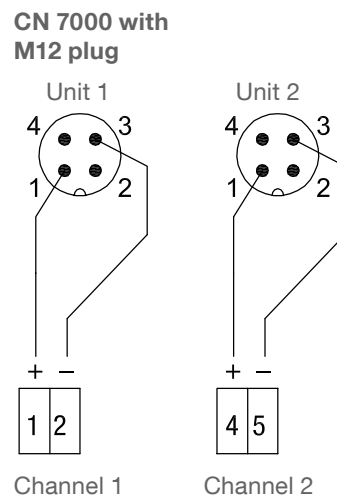
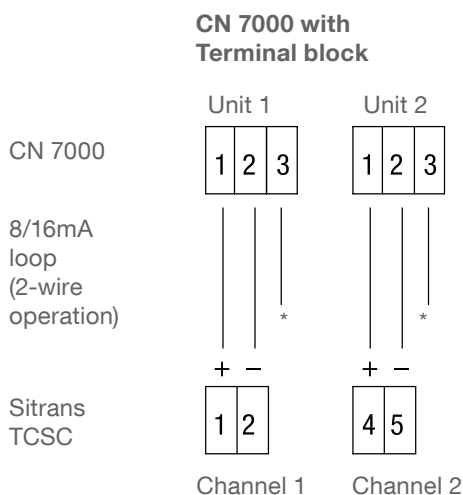

* Cable shield, see page 24

Adjustment Sitrans SCSC/TCSC

The Sitrans SCSC/TCSC with connection of CN 7000 is adjusted as follows:

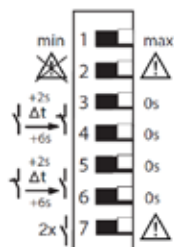

DIL-switch:

- 1 Mode (min./max. adjustment)
- 2 Switch-on pulse monitoring On/Off
- 3 to 7

Setting:

- Max.
- On
- *

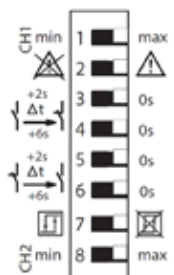

DIL-switch:

- 1 Mode (min./max. adjustment), channel 1
- 2 Switch-on pulse monitoring On/Off
- 3 to 6
- 7 Two-point control On/Off
- 8 Mode (min./max. adjustment), channel 2

Setting:

- Max.
- On
- *
- Off
- Max.

* These settings are not defined for the interaction with CN 7000 and can be set by the user under consideration of the WHG requirements.

Troubleshooting

LEDs			Behaviour	Cause	Action
Green Power supply	Yellow Signal output	White Probe covered/ uncovered			
OFF	OFF	OFF		Proper power supply not applied to device Connector came loose Defective component in device	Check power supply Refasten connector Contact distributor
ON	ON or OFF	ON	Probe is uncovered but LED white states covered	Sensitivity is set too high. Either sensitivity setting not properly done or too much material buildup	Reduce sensitivity (see page 32 ff). If applicable clean probe from buildup
ON	ON or OFF	OFF	Probe is covered but LED white states uncovered	Sensitivity is set too low. Either sensitivity setting not properly done or too low dielectric constant from material.	Increase sensitivity (see page 32 ff). Dielectric constant of material must be 1.5 or more
ON	ON or OFF	ON or OFF	Yellow LED lights opposite to white LED when this is not meant to happen	Incorrect polarity on power supply	Reverse polarity on power supply. See Switching logic on page 26
ON	OFF	Blinks slowly (every 2 seconds)	Relay = idle	Potentiometer is on the clockwise stop position and thus the 4-20mA continuous mode is active (see page 40)	If the switch mode is required, go to switchpoint setting (see page 32 ff)
ON	Blinks for a few times, then stops blinking	ON or OFF	Blinking happens after the potentiometer was turned	This is a normal operation. The blinking indicates the position of the potentiometer after it was turned (see page 39)	No action required
ON	OFF	Blinks fast (twice per second)	Current loop = 3.6mA, Relay = idle	Diagnostics has indicated a failure	Contact distributor
ON	ON or OFF	ON or OFF	No respond (change of white and yellow LED) when potentiometer is turned and probe is uncovered	Defective component in device	Contact distributor
ON	ON or OFF	ON or OFF	Unequal current in current loop	Loop circuitry is connected against earth	Remove earth connection from loop circuitry

Transport and Storage

Transport

Observe the instructions as stated on the transport packaging, otherwise the products may get damaged.

Transport temperature: -40 .. +80°C (-40 .. +176°F)

Transport humidity: 20 .. 85%

Transport incoming inspections must be carried out to check for possible transport damage.

Storage

Products must be stored at a dry and clean place. They must be protected from influence of corrosive environment, vibration and exposure to direct sunlight.

Storage temperature: -40 .. +80°C (-40 .. +176°F)

Storage humidity: 20 .. 85%

Maintenance

Opening the lid (cover)	<p>⚠ Before opening the lid for maintenance reasons observe following items:</p> <ul style="list-style-type: none"> • No dust deposits or whirlings are present. • No rain can enter into the housing.
Frequent check of the unit	<p>⚠ To ensure durable safety in hazardous locations and with electrical safety, following items must be checked frequently depending on the application:</p> <ul style="list-style-type: none"> • Mechanical damage or corrosion of any components (housing side and process side) and of the field wiring cables. • Tight sealing of the process connection, cable glands and enclosure lid. • Properly connected external PE cable (if present).
Cleaning	<p>⚠ If cleaning is required by the application, following must be observed:</p> <ul style="list-style-type: none"> • Cleaning agent must comply with the materials of the unit (chemical resistance). • Mainly the lid sealing, cable gland and the surface of the unit must be considered. <p>The cleaning process must be done in a way, that:</p> <ul style="list-style-type: none"> • The cleaning agent cannot enter into the unit through the lid sealing or cable gland. • No mechanical damage of the lid sealing, cable gland or other parts can happen. <p>Units with EHEDG certification, which are used in the respective EHEDG applications, must be cleaned according to the respective regulations.</p> <p>A possible accumulation of dust on the unit does not increase the maximum surface temperature and must therefore not be removed for purposes of maintaining the surface temperature in hazardous locations.</p>
Max. temperature for CIP	<p>⚠ 135°C (275°F), duration 60min 150°C (302°F), duration 30min (only for CN 7120 with process connection G 1/2" hygienic)</p> <ul style="list-style-type: none"> • Ambient temperature limited to 50°C (122°F), unit de-energized.
Function test	<p>⚠ A frequent function test may be required depending on the application.</p> <ul style="list-style-type: none"> • Observe all relevant safety precautions related with a safe work depending on the application (e.g. hazardous locations, hazardous material, electric safety, process pressure). <p>This test does not proof if the unit is sensitive enough to measure the material of the application.</p> <p>Function test is done by touching the probe with appropriate means (e.g. grounded metal plate or hand) and monitor if a correct change of the signal output from uncovered to covered happens.</p>
Production date	<p>The production date can be traced by the serial number on the typeplate. Please contact the manufacturer or your local distributor. For ATEX/IEC-Ex versions see page 15.</p>
Spare parts	<p>All available spare parts are stated in the selection list</p>

Probe modifications / Disposal

Probe modifications - Shortening the extension cable (CN 7150)

The extension cable of CN 7150 can be shortend on site. See external manual dm140000.

Disposal

The product consists of materials which can be recycled, details of the used materials see chapter "Technical data - mechanical data". Recycling must be done by a specialised recycling company.