

POSICHRON® PCRP32 Round Profile Housing with Analog Output

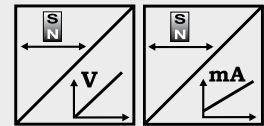

POSICHRON® position sensor in a stainless steel pressure tube

- Protection class IP67/69K, IP68
- Underwater applications, permanent pressure-proof up to 15 bar
- Measurement range 0 ... 100 to 0 ... 5750 mm
- Absolute position measurement
- Contact-free
- Seawater-proof
- Analog output



Specifications	Output	Voltage Current
	Resolution	Refer to output specification
Sampling rate	Up to 1 kHz, depending on the measurement range	
Linearity	Ranges >500 mm: L10 = ±0.10 % f.s. L02 = ±0.02 % f.s. Ranges ≤500 mm: L10 = ±0.5 mm L02MM = ±0.2 mm	
Repeatability	±3 µm	
Housing material	Stainless steel 1.4404	
Protection class	IP68 (permanent pressure-proof up to 15 bar), IP67/69K	
Shock	EN 60068-2-27:1993, 50 g 11 ms, 100 shocks	
Vibration	EN 60068-2-6:1995, 20 g 10 Hz-2 kHz, 10 cycles	
Connection	Cable 2 m	
EMC, temperature	Refer to output specification	

Order Code PCRP32 1 channel, industry standard

Model name

Measurement range (in mm)

100 ... 5750 in 10 mm increments
Other ranges on request

Output

420T = 4 ... 20 mA signal conditioner, 3 wire

Linearity

L02 / L02MM / L10 (for definition see "Specifications" above)

Connection

KAB2M = Cable, standard length 2 m, other lengths upon request

PCRP32 - [] - [] - [] - []

Order code position magnet (see page 47)

PCMAG5

Order example: PCRP32 - 1500 - 420T - L02 - KAB2M

Order Code PCRP32

**1 or 2 channel,
configurable**

PCRP32 - [] - [] - [] - [] - [] - []

Model name

Measurement range (in mm)

100 ... 5750 in 10 mm increments

Output

- U2 = 0.5 ... 10 V signal conditioner
- U3 = 0 ... 5 V signal conditioner
- I1 = 4 ... 20 mA signal conditioner (3 wire)

Function and characteristics output 1

- P1A = Position magnet 1, increasing
- P1D = Position magnet 1, decreasing
- PMU = Start value, direction & end value adjustable by the customer (1 channel only)
- DA = Difference magnet 1/2, increasing (2 magnets required)
- DD = Difference magnet 1/2, decreasing (2 magnets required)

Function and characteristics output 2 (option)

- P2A = Position magnet 2, increasing
 - P2D = Position magnet 2, decreasing
 - DA = Difference magnet 1/2, increasing
 - DD = Difference magnet 1/2, decreasing
- } 2 magnets required

VZx.x = Velocity with direction detection (with 1 magnet only)

VZx.x = Velocity in steps of 0.1 m/s

Example: VZ1.5	towards start position		towards end position
	-1.5 m/s	0	+1.5 m/s
Output U2:	0.5 V	5.25 V	10 V
Output I1:	4 mA	12 mA	20 mA

VAx.x = Velocity without direction detection (with 1 magnet only)

VAx.x = Velocity in steps of 0.1 m/s

Example: VA1.5	towards start position		towards end position
	-1.5 m/s	0	+1.5 m/s
Output U2:	10 V	0.5 V	10 V
Output I1:	20 mA	4 mA	20 mA

Linearity

L02 / L02MM / L10 (for definition see "Specifications" above)

Connection

KAB2M = Cable, standard length 2 m, other lengths upon request

Custom outputs are available upon request.

1. Order example: PCRP32 - 1000 - U2 - P1D - L02 - KAB2M

Round profile, measurement range 1000 mm, 1 voltage output 0.5 ... 10 V (U2)
Output 1: Position magnet 1, decreasing signal (P1D)
Output 2: Not used

2. Order example: PCRP32 - 1000 - I1 - P1A - P2D - L02 - KAB2M

Round Profile, measurement range 1000 mm, 2 current outputs 4 ... 20 mA (I1)
Output 1: Position magnet 1, increasing signal (P1A)
Output 2: Position magnet 2, decreasing signal (P2D)

3. Order example: PCRP32 - 1000 - U2 - P1A - VZ1.0 - L02 - KAB2M

Round Profile, measurement range 1000 mm, 2 voltage outputs 0.5 ... 10 V (U2)
Output 1: Position magnet 1, increasing signal (P1A)
Output 2: Velocity magnet 1, -1 m/s ... 1 m/s for range 0.5 ... 10 V (VZ1.0)



POSICHRON® position sensor in a stainless steel pressure tube

- Protection class IP67/69K, IP68
- Underwater applications, permanent pressure-proof up to 15 bar
- Measurement range 0 ... 100 to 0 ... 5750 mm
- Absolute position measurement
- Contact-free
- Seawater-proof
- Multi-magnet operation
- Pulse output (start/stop)

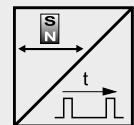

Specifications	Output	Pulse output (start/stop)
	Resolution	Essentially infinite
	Sampling rate	Up to 1 kHz, depending on the measurement range
	Linearity	Ranges >500 mm: L10 = ±0.10 % f.s. L02 = ±0.02 % f.s. Ranges ≤500 mm: L10 = ±0.5 mm L02MM = ±0.2 mm
	Repeatability	±3 µm
	Housing material	Stainless steel 1.4404
	Protection class	IP68 (permanent pressure-proof up to 15 bar), IP67/69K
	Shock	EN 60068-2-27:1993, 50 g 11 ms, 100 shocks
	Vibration	EN 60068-2-6:1995, 20 g 10 Hz-2 kHz, 10 cycles
	Connection	Cable 2 m
EMC, temperature	Refer to output specification	

Order Code PCRP32

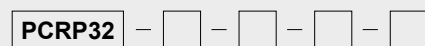

Model name

Measurement range (in mm)

100 ... 5750 in 10 mm increments
Other ranges on request

Output

STSP = Pulse output (start/stop)

Linearity

L02 / L02MM / L10 (for definition see "Specifications" above)

Connection

KAB2M = Cable, standard length 2 m, other lengths upon request

Order code position magnet (see page 47)

PCMAG5

Order example: PCRP32 - 1000 - STSP - L02 - KAB2M



POSICHRON® position sensor in a stainless steel pressure tube

- Protection class IP67/69K, IP68
- Underwater applications, permanent pressure-proof up to 15 bar
- Measurement range 0 ... 100 to 0 ... 5750 mm
- Absolute position measurement
- Contact-free
- Seawater-proof
- Synchronous serial interface (SSI)

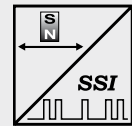

Specifications		
Output	Synchronous serial (SSI)	
Resolution	5, 10, 20, 50, 100 µm	
Sampling rate	Up to 1 kHz, depending on the measurement range	
Linearity	Ranges >500 mm: L10 = ±0.10 % f.s. L02 = ±0.02 % f.s. Ranges ≤500 mm: L10 = ±0.5 mm L02MM = ±0.2 mm	
Repeatability	±3 µm	
Housing material	Stainless steel 1.4404	
Protection class	IP68 (permanent pressure-proof up to 15 bar), IP67/69K	
Shock	EN 60068-2-27:1993, 50 g 11 ms, 100 shocks	
Vibration	EN 60068-2-6:1995, 20 g 10 Hz-2 kHz, 10 cycles	
Connection	Cable 2 m	
EMC, temperature	Refer to output specification	

Order Code PCR32

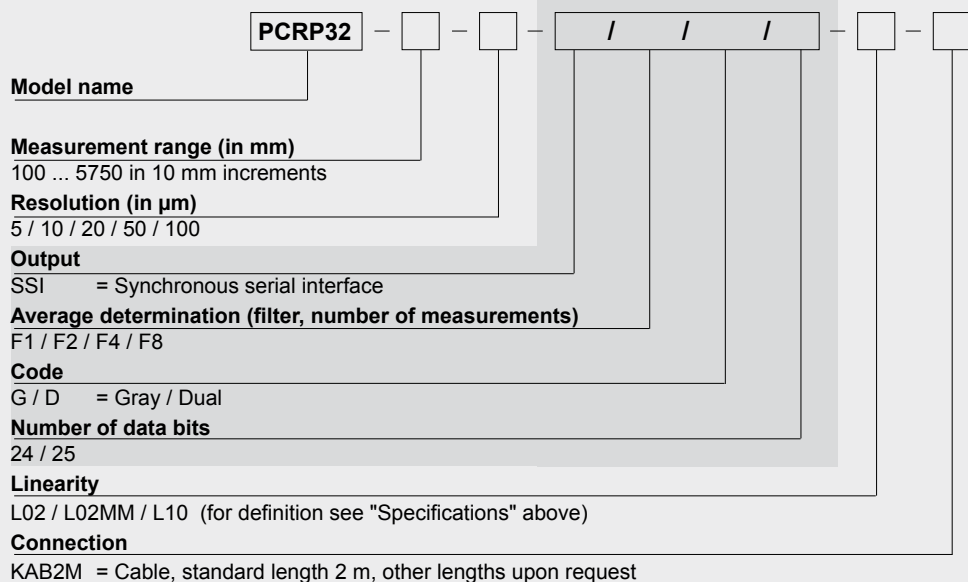

Order code position magnet (see page 47)

PCMAG5

Order example: PCR32 - 2000 - 5 - SSI/F8/G/24 - L02 - KAB2M

POSICHRON[®]
PCRP32
Round Profile Housing

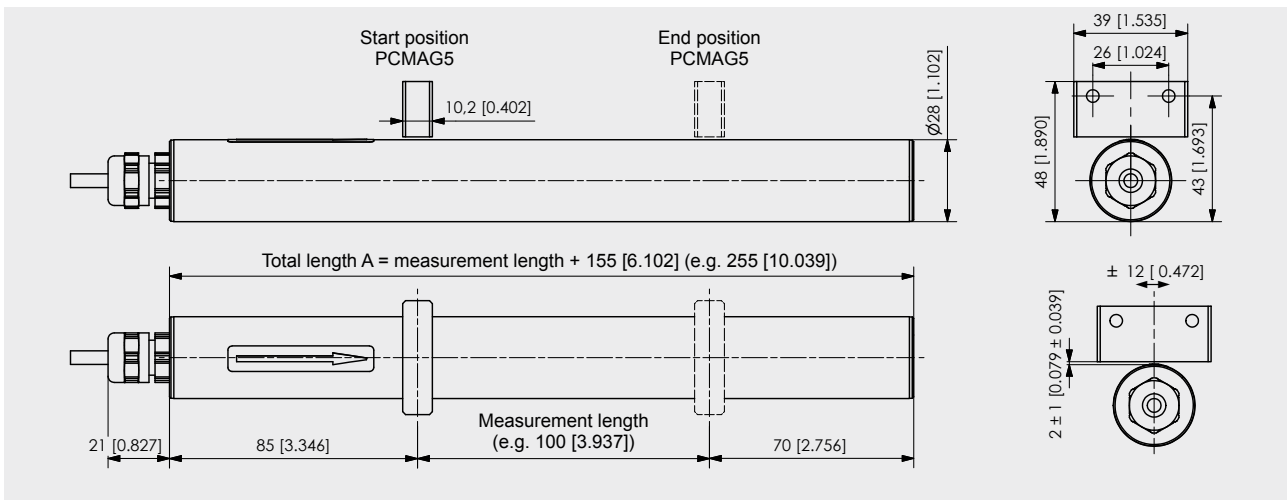

Dimensions in mm [inch]

Dimensions informative only.

For guaranteed dimensions consult factory.

Other designs can be realized on request

POSICHRON®
PCRP
Mounting set - Magnets



PCRP21-BFS4
Mounting set

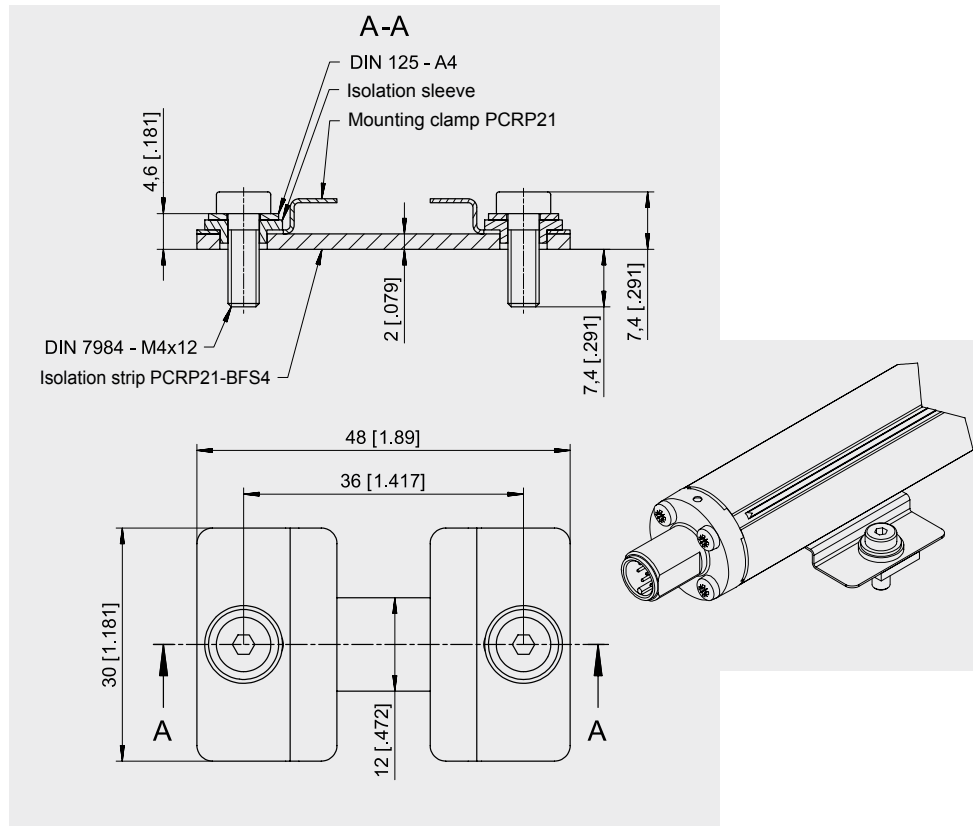

PCMAG5
Standard magnet

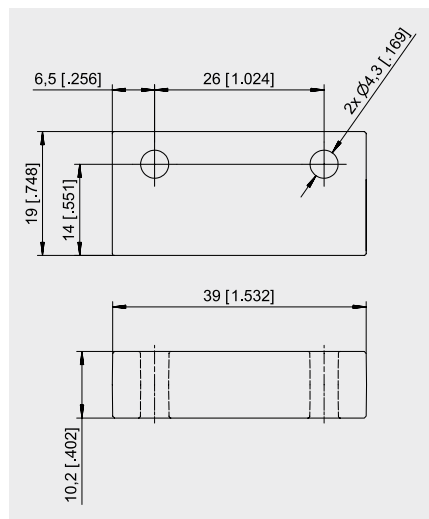

Dimensions in mm [inch]

Dimensions informative only.
 For guaranteed dimensions consult factory.

PCRP MAG6
**Guided magnet slider
 for PCRP21 with internal
 position magnet**

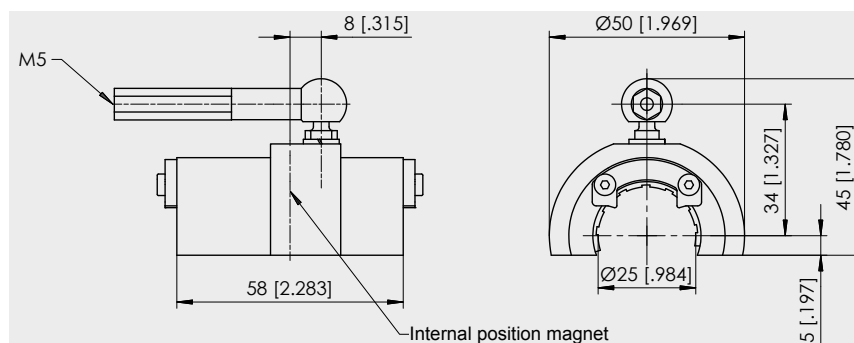

Not to be used for a large number of operation cycles!

POSICHRON® Output Specification 420T Industry Standard



Signal conditioner 420T Current output (3 wire)	Excitation voltage	18 ... 27 V DC (18 ... 36 V DC as option)
	Excitation current	Typ. 70 mA, 80 mA max.
	Load resistor	350 Ω max.
	Output current	4 ... 20 mA, 30 mA max. (at failure)
	Resolution	Essentially infinite
	Stability (temperature)	±50 x 10 ⁻⁶ / °C f.s.
	Protection	Reverse polarity, short circuit
	Output noise	0.5 mV _{RMS}
	Operating temperature	-40 ... +85 °C
	Immunity to interference (EMC)	According to EN 61326:2004

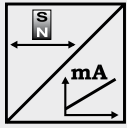

Signal diagram

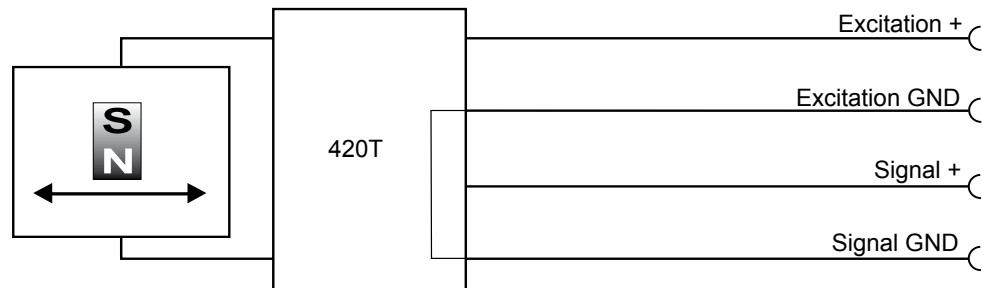

Signal wiring	Output signals 420T	Connector pin	Cable output color * (not for PCST27 and PCRP32)
	Excitation +	1	white
	Excitation GND	2	brown
	Signal +	3	green
	Signal GND	4	yellow

Connection

Mating connector

View to
sensor
connector

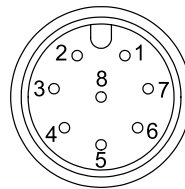

CONN-M12-8M

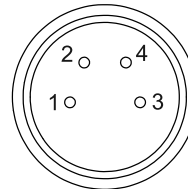

CONN-M8-4M

*** Please note the different colors of the assembled accessory cable!**

POSICHRON®

Output Specification U2, U3 and I1

Configurable, 1 or 2 channels



Signal conditioner U2, U3 Voltage output 	Excitation voltage	18 ... 27 V DC
	Excitation current	Typ. 35 mA, 80 mA max.
	Output voltage	U2: 0.5 ... 10 V; U3: 0 ... 5 V
	Output current	2 mA max.
	Output load	> 5 kΩ
	Resolution	16 bit
	Stability (temperature)	$\pm 50 \times 10^{-6} / ^\circ\text{C}$ f.s.
	Protection	Reverse polarity, short circuit
	Output noise	0.5 mV _{RMS}
	Operating temperature	-40 ... +85 °C
Immunity to interference (EMC)	According to EN 61326:2004	

Signal diagram

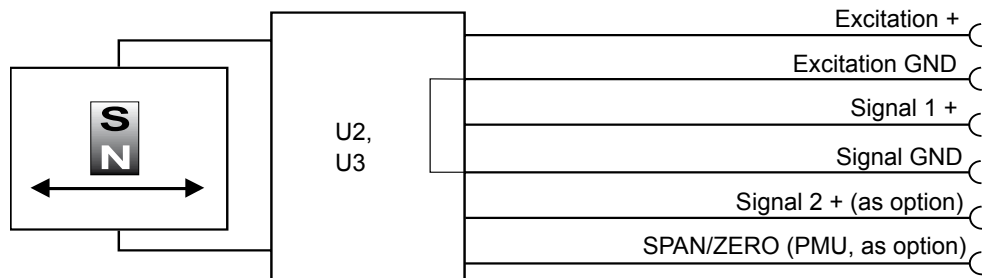

Signal conditioner I1 Current output (3 wire) 	Excitation voltage	18 ... 27 V DC
	Excitation current	Typ. 60 mA, 80 mA max.
	Load resistor	350 Ω max.
	Output current	4 ... 20 mA, 30 mA max (at failure)
	Resolution	16 bit
	Stability (temperature)	$\pm 50 \times 10^{-6} / ^\circ\text{C}$ f.s.
	Protection	Reverse polarity, short circuit
	Output noise	0.5 mV _{RMS}
	Operating temperature	-40 ... +85 °C
Immunity to interference (EMC)	According to EN 61326:2004	

Signal diagram

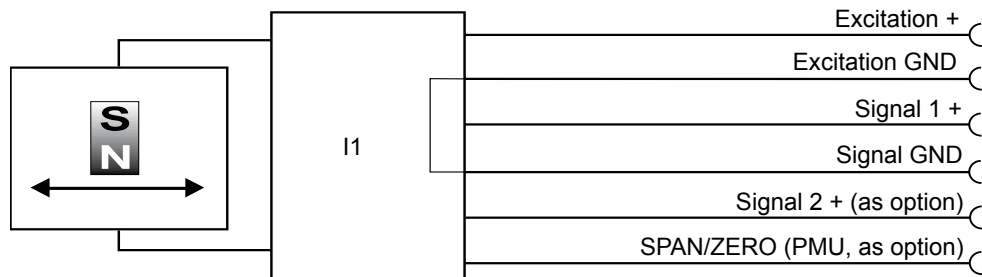

Signal wiring	Output sigals U2, U3, I1	Connector pin	Cable output, wire color (not for PCST27 and PCR32)
	Excitation +	1	white
	Excitation GND	2	brown
	Signal 1 +	3	green
	Signal GND	4	yellow
	Signal 2 + (as option *)	5	grey
	SPAN/ZERO (PMU **, as option)	6	pink

* When using multiple magnets the distance between two magnets must be min. 70 mm to identify the single magnets definitely.

** Description page 59

Connection

Mating connector

View to
sensor
connector

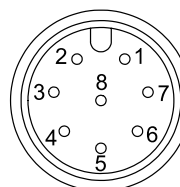

CONN-M12-8M

POSICHRON® Output Specification Pulse Interface STSP



Pulse interface STSP

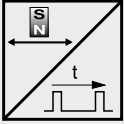

Excitation voltage	18 ... 27 V DC, residual ripple 10 mV _{SS}
Excitation current	Typ. 60 mA, 150 mA max.
Stability (temperature)	±50 x 10 ⁻⁶ / °C f.s.
Wave velocity v _s	2600 ... 2900 m/s
Level INIT and START/STOP	RS422
Protection	Reverse polarity, short circuit
Operating temperature	-40 ... +85 °C
EMC	According to EN 61326:2004

Signal diagram

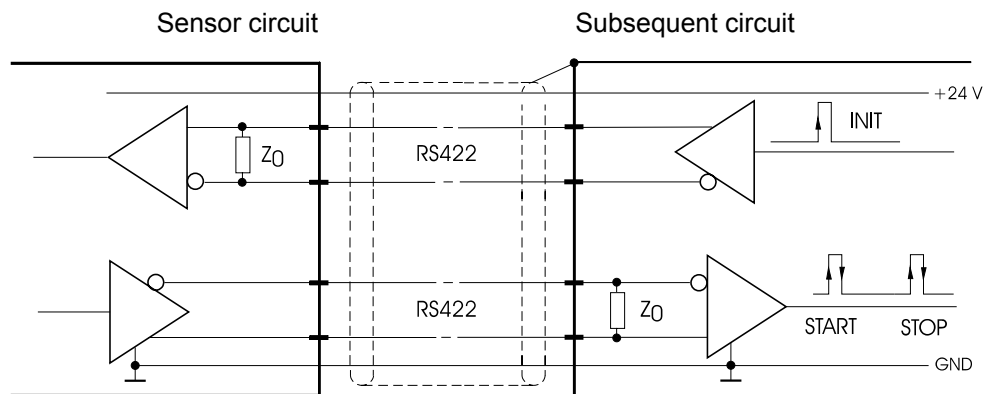

The subsequent circuit generates a request pulse via the INIT line. The position sensor responds with a START and a STOP signal.

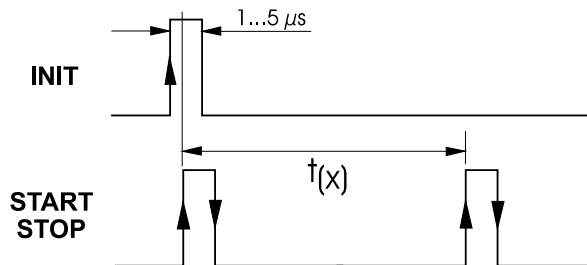

To calculate the position value the time interval $t_{(x)}$ must be multiplied with the conversion factor v_s specified on the type label.

$$\text{Position value } x = t_{(x)} \cdot v_s$$

When using multiple magnets every single magnet generates its own STOP signal. To identify the single magnets definitely the distance between two magnets must be min. 70 mm.

Signal wiring	Pulse interface	Connector pin	Cable output color (not for PCST27 and PCRP32)
Excitation +		1	white
Excitation GND		2	brown
INIT		3	green
INIT		4	yellow
STSP		5	grey
STSP		6	pink

Connection Mating connector

View to sensor
connector

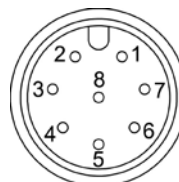

CONN-M12-8M

POSICHRON® Output Specification SSI



Description

The data transmission takes place by means of the two signals CLOCK and DATA. The processing unit (PLC, microcomputer) sends pulse sequences which clock the data transmission at the required transfer rate. With the first falling edge of the pulse sequence the position of the sensor is recorded and stored. The following rising edges control the bit-by-bit transfer of the data word. After a delay time the next new position information can be transmitted.

Data format (Train of 26 pulses)

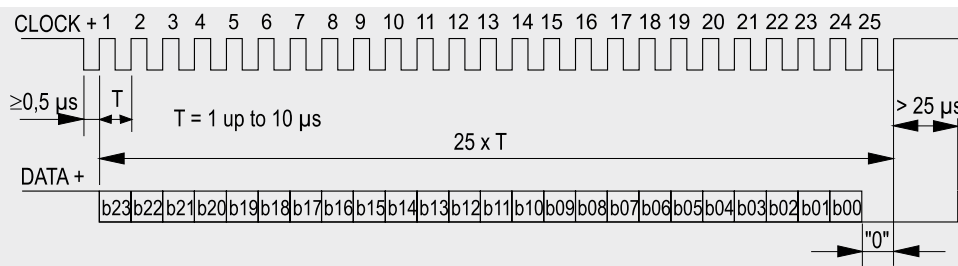

Synchronous serial interface SSI

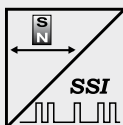

Output	RS422
Excitation voltage	18 ... 27 V DC, residual ripple 10 mV _{SS}
Excitation current	Typ. 80 mA, 150 mA max.
Clock frequency	100 kHz ... 1 MHz
Code	Gray code, dual code
Resolution	≥ 5 μm
Delay between pulse trains	>25 μs
Filter	Average determination, see page 59
Stability (temperature)	±50 x 10 ⁻⁶ / °C f.s.
Operating temperature	-40 ... +85 °C
Immunity to interference EMC	According to EN 61326:2004

Signal diagram

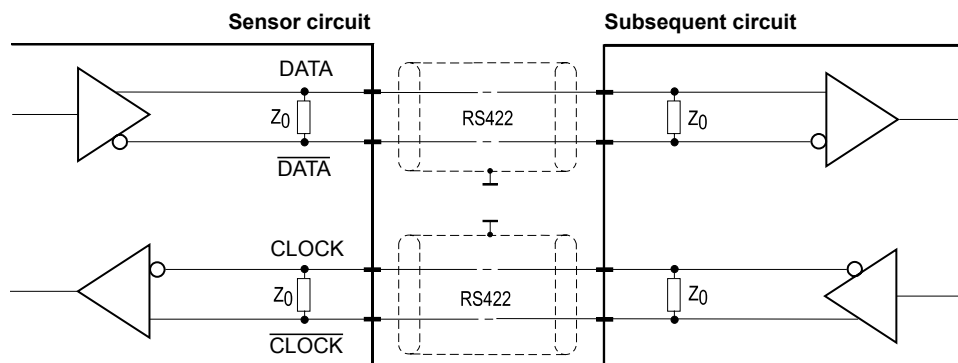

Cable length	Baud rate
50 m	100-1000 kHz
100 m	100-300 kHz

Note:
Extension of the cable length will reduce the maximum transmission rate.
The signals CLOCK/CLOCK and DATA/DATA must be connected in a twisted pair cable, common shielded.

Signal wiring

Signal name	Connector pin	Cable output color (not for PCST27 and PCR32)
Excitation +	1	white
Excitation GND	2	brown
CLOCK	3	green
CLOCK	4	yellow
DATA	5	grey
DATA	6	pink

View to sensor connector

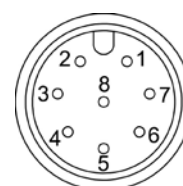

CONN-M12-8M

POSICHRON® Output Specification CANopen



Description

CANopen interface with process data for position and cam functions, programmable are preset, resolution, filtering and cam switching points.

Interface CANOP 	Communication profile	CANopen CiA 301 V 4.02, Slave
	Encoder profile	Encoder CiA 406 V 3.2
	Error Control	Node Guarding, Heartbeat, Emergency Message
	Node ID	Adjustable via LSS or via object dictionary
	PDO	4 TxPDO, 0 RxPDO, no linking, static mapping
	PDO Modes	Event-/Time triggered, Remote-request, Sync cyclic/acyclic
	SDO	1 server, 0 client
	CAM	2 cams
	Certified	Yes
	Transmission rates	50 kBaud to 1 MBaud, adjustable via LSS or via object dictionary
	Nodes	127 max.
	Bus connection	M12 connector, 5 pins
	Integrated bus terminating resistor	As option (output CANOP/RT)
Bus, galvanic isolated	No	

Specifications	Excitation voltage	8 ... 36 V DC
	Excitation current	Typ. 30 mA for 24 V, max. 100 mA
	Number of position magnets	1 ... 4
	Resolution	50 µm
	Measuring rate	1 kHz (asynchronous)
	Stability (temperature)	±50 x 10 ⁻⁶ / °C f.s.
	Repeatability	1 LSB
	Operating temperature	-40 ... +85 °C
	Protection	Reverse polarity, short circuit
	Dielectric strength	1 kV (V AC, 50 Hz, 1 min.)
	Environment - EMC Automation	EN 61326:2004

When using multiple magnets the distance between two magnets must be min. 70 mm to identify the single magnets definitely.

Signal wiring / connection	Signal name	Connector pin (color)
	Shield	1 (grey)
	Excitation +	2 (white)
	GND	3 (brown)
	CAN-H	4 (green)
	CAN-L	5 (yellow)

View to sensor connector

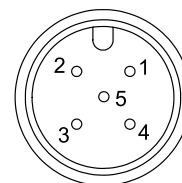

CAN bus wiring

